

**INSTALLATION  
AND  
OPERATION  
MANUAL  
FOR ROPER  
V05, V10, V20, V30  
TYPE 1  
PUMPS**



© 1991 by Roper Pump Company

Roper Pump Company  
P.O. Box 269  
Commerce, Georgia 30529

Telephone: (404) 335-5551  
TeleFAX: (404) 335-5505  
Area Code to be (706) after May  
1992

PART NO. G12-243

# TABLE OF CONTENTS

Section		Page
1.	<b>INTRODUCTION</b> . . . . .	<b>1</b>
2.	<b>SAFETY PRECAUTIONS</b> . . . . .	<b>2</b>
3.	NAMEPLATE DATA . . . . .	4
4.	<b>PREOPERATION CHECKS</b> . . . . .	<b>6</b>
5.	PREPARATION OF FOUNDATION . . . . .	7
6.	<b>ADDITIONAL IMPORTANT WARNINGS AND INFORMATION</b> . . . . .	<b>7</b>
7.	INSTALLATION OF PIPES . . . . .	9
8.	THREADED PORT CONNECTIONS . . . . .	9
9.	DIRECTION OF ROTATION . . . . .	10
10.	RELIEF VALVE . . . . .	11
11.	RELIEF VALVE ADJUSTMENT . . . . .	12
12.	RELIEF VALVE DISASSEMBLY . . . . .	12
13.	RELIEF VALVE ASSEMBLY . . . . .	13
14.	INSTRUCTIONS FOR PUMP DISASSEMBLY . . . . .	13
15.	INSTRUCTIONS FOR PUMP ASSEMBLY . . . . .	14
16.	PUMP SECTIONAL DRAWINGS . . . . .	16
17.	PARTS LIST . . . . .	18
18.	CHECKING PUMP PERFORMANCE . . . . .	19
19.	REPLACEMENT PARTS . . . . .	21

**NOTE: BOLD FACE TOPICS CONTAIN IMPORTANT SAFETY INFORMATION**

## 1. INTRODUCTION

### **! WARNING**

**This pump contains strong magnetic fields. Keep away from pacemakers and other medical equipment that is sensitive to magnetic fields.**

### **! IMPORTANT**

**THIS MANUAL MUST ACCOMPANY THE PUMP UPON ALL TRANSFERRALS. MAKE SURE THE OPERATOR OF THE EQUIPMENT HAS READ AND UNDERSTANDS THIS MANUAL BEFORE OPERATING THE PUMP OR ANY RELATED EQUIPMENT.**

When properly selected, installed, operated, and maintained, Roper pumps will provide long, dependable service. Remember, faulty selection and installation form the basis of more pump troubles than all other causes combined. No amount of maintenance can compensate for selection and installation mistakes. Read and understand this manual carefully before installing or operating this pump.

This pump is satisfactory for its rated conditions. Its operation beyond these conditions may subject it to stresses and strains that it is not designed to withstand.

This manual will cover standard pumps and most spec. number pumps. Appearance may vary among pumps and construction may vary on spec. number pumps. Specification numbers are assigned to pumps with other than standard features. Roper produces specific manuals for most standard line pump models. Contact Roper to find out if the pump model you have has a specific manual and to request a copy.

If there is any question concerning the ratings, instructions, or compatibility of the pump with the pumped liquid, consult a Roper distributor or:

**Roper Pump Company  
P.O.Box 269 Old Maysville Road  
Commerce, Georgia, USA 30529  
Telephone: (404) 335-5551  
TeleFAX: (404) 335-5505  
Area Code to be (706) after May 1992**

### **! IMPORTANT**

Read the following before starting the pump! Failure to heed these warnings may result in an accident causing physical damage, serious personal injury, or death!

- Read and understand all tags and installation and operating instructions.
- Know the operating conditions.
- Open all lines before starting pump.
- **WARNING! DO NOT** operate this equipment in excess of its rated capacity, pressure, speed, and temperature or other than according to the instructions contained in this manual.
- **WARNING!** Install and properly set devices into the system to prevent the chance of too much pressure, high temperature, and driver overload. The pump is not provided with these devices.

- **WARNING!** Proper measures and safeguards must be taken to avoid spillage and overflow from overfilling or putting too much pressure on any component of the system. This includes the receiver and lines.
- **WARNING! DO NOT** allow motor to continue to run if the pump has stopped turning. Heat will build up rapidly in the area of the magnetic coupling.
- **WARNING! DO NOT** attempt to disassemble or assemble pump without reading and understanding the instructions in this manual. Disassembly of the pump will expose strong magnets that must be handled properly to avoid possible injury and/or equipment damage.
- *These instructions cannot possibly cover every situation concerning the operation, inspection, adjustment, and test of the equipment furnished. Roper Pump Company must presume that the crew using this pump has ample knowledge and training to apply sound safety and operational practices that may not be mentioned.*

---

## 2. SAFETY PRECAUTIONS

### **WHEN LIQUID BEING PUMPED IS HAZARDOUS OR VOLATILE, ALWAYS TAKE FULL PRECAUTIONS. THIS INCLUDES THE RUN-IN PERIOD AND DURING DISASSEMBLY AND ASSEMBLY OF PUMP.**

Controls, guards, walkways, machine arrangement, crew training, etc., are all necessary factors in the creation of a safe, practical installation and are generally not a part of our services. *It is the responsibility of the contractor, installer, owner, and user to add to the materials furnished by Roper to result in a safe installation and to comply with OSHA, state and local laws, and the ANSI Safety Code.*

There are many kinds of devices for pumps and systems such that if one component in a system is stopped, other equipment feeding or following it also can be automatically stopped. Serious thought should be given to the installation of these types of devices in every pump system.

- **DO NOT** work on or stand close to this pump if you have a pacemaker or other medical equipment that is sensitive to magnetic fields.
- **DO NOT** attempt to install, operate, or perform maintenance on this equipment without first reading and understanding the material in this manual. Also, read and understand all tags and any other documentation accompanying the pump.
- **DO NOT** operate this equipment in excess of its rated capacity, pressure, speed, or temperature or other than according to the instructions contained in this manual.
- **DO NOT** continue to operate this equipment if there is a failure of any part of the equipment or system. Correct the failure before operating the equipment.
- **DO NOT** bypass safety controls or guards. Their purpose is to protect and they must be in proper working order.
- **DO NOT** operate equipment without proper guards in place.
- **DO NOT** walk, stand, sit, or lean on guards.
- **DO NOT** work on a pump while it is operating.

- **DO NOT** place hands, feet, head, or any other part of your body in any pump opening while the pump can be operated.
  - **DO NOT** poke or prod material in the pump.
  - **DO NOT** work on this equipment if there is the slightest chance of it becoming energized by accident. Lock out the energy source to the driver.
  - **DO NOT** wear loose or dangling clothing or jewelry near the equipment. It could become caught and possibly cause serious injury.
  - **DO NOT** use metallic or hard faced striking tools when the need for tapping parts into position arises. Hard faced striking tools may damage parts or they may fracture or chip and send particles flying that could cause possible injury.
  - **DO NOT** allow spills to remain in the work area. Clean up spills immediately. Oils, greases, and other fluids used in the equipment may create hazards if not cleaned up immediately after a spill.
  - **DO NOT** attempt to install, use, or repair this equipment while under the influence of any substance that may impair physical or mental abilities. This includes, but is not limited to, alcohol and prescription and nonprescription drugs.
  - **DO NOT** dispose of fluoroelastomers by burning. Toxic vapors are released by this compound upon combustion.
  - **DO NOT** attempt to disassemble or assemble pump without using extreme caution near magnets. These magnet sets are extremely powerful and serious injury may result if proper procedures are not followed. **NEVER** allow magnet sets to be closer than two feet from each other or to other ferrous materials while pump is disassembled. Serious injury and/or equipment damage may result.
- 
- **DO** completely read and understand the information contained in this manual. The operator of the equipment must be familiar with these instructions.
  - **DO** always keep safety in mind.
  - **DO** know the operating conditions of the equipment.
  - **DO** take proper measures and precautions to avoid spillage and overflow from overfilling or putting too much pressure on any component of the system.
  - **DO** identify all possible hazards and decide what controls are needed. Remember, only you understand your product and system characteristics fully. *The ultimate responsibility for the application and safety is with you.*
  - **DO** install and properly set devices into the system to prevent the chance of overpressure, excessive temperature, and driver overload.
  - **DO** provide guards for all exposed rotating parts, including parts of the drive system, to prevent possible injury.
  - **DO** be careful when working near an operating pump. Contacting or getting caught in rotating parts could cause serious or fatal injury.

- **DO** keep equipment in good working order, especially safety devices and guards.
- **DO** be aware of your location relative to the equipment.
- **DO** wear proper clothing near the equipment. Safety glasses or goggles, and safety shoes are recommended. They will help reduce the chance of injury.
- **DO** use soft faced striking tools when the need for tapping parts into position arises. Rubber or plastic faced striking tools are recommended.
- **DO** practice good housekeeping. Clean up spills immediately. Keep the work area clean to avoid hazards. Always be sure of your footing around the equipment to avoid a possible fall and injury.
- **DO** use proper tools. Avoid *cheater* bars as they are a source for serious injury should they slip or break.

### 3. NAMEPLATE DATA

Roper identifies each pump manufactured by a metal nameplate attached to the pump. This nameplate describes how the pump was built at the factory. Copy the nameplate data from your pump in the area provided below. Use this for ready reference when ordering repair parts or when consulting with a Roper distributor or Roper Pump Company about this pump.

FIGURE NUMBER: \_\_\_\_\_

SPEC NUMBER: \_\_\_\_\_

TYPE NUMBER: \_\_\_\_\_

SERIAL NUMBER: \_\_\_\_\_

### PUMP NOMENCLATURE

**Example: V05P1ANCDLH SPEC XXX TYPE 1 SERIAL ZZZ**

1. The FIGURE number consists of an eleven digit number.

- The first digit (V in the example) indicates the V series magnetic drive gear pump.
- The second and third digits (05) indicates the appropriate theoretical displacement in tenths of gallon per 1000 revolutions.

Tenths of Gallon/1000 Rev. [Liters/1000 Rev.]

05 [1.9]  
10 [3.8]  
20 [7.6]  
30 [11.4]

- The fourth digit (P) indicates the type of faceplate on pump.
  - P - Plain faceplate
  - R - Relief valve faceplate

- The fifth digit (1) indicates magnetic coupling size.
  - 1 - 5 ft-lb
- The sixth digit (A) indicates the type of magnet.
  - A - Neodymium
  - Z - Samarium Cobalt
  - X - Pump less magnetic coupling and containment barrier
- The seventh digit (N) indicates o-ring type.
  - N - Buna
  - V - Fluoroelastomer
  - E - EPDM
  - S - TFE Encapsulated
  - T - Solid TFE
  - U - Perfluoroelastomer
- The eighth digit (C) indicates bearing material.
  - C - Carbon
  - B - Bronze
  - Y - Iron
- The ninth digit (D) indicates housing material.
  - D - Ductile Iron except bracket
  - F - Iron
- The tenth digit (L) indicates pump mounting.
  - L - Footless
  - K - With foot
  - J - Pump less bracket and foot
- The eleventh digit (H) indicates final unit.
  - H - Bare pump without accessories
  - M - Mounted pump and accessories
  - O - Less bracket and coupling

**NOTE:** The preceding description of the figure number is to assist in identifying your Roper V series pump only. **DO NOT** attempt to derive any ratings or performance from the figure number. **DO NOT** use the explanation of the figure number to construct your own pump, not all combinations are possible. For assistance in pump selection, it is recommended that you consult a Roper distributor or Roper Pump Company.

2. Occasionally, special pumps or configurations are required which are unique for a particular application. These modifications are clarified by a SPECification number. Identification of any items different than a standard pump can be made by consulting a Roper distributor or Roper Pump Company.

3. The TYPE number is a number used by Roper for in-house identification of construction and hydraulics. Always include the type number in any references to the pump.
4. The SERIAL number is a unique number assigned to each pump built by Roper Pump Company.

In any communication concerning this pump, always be sure to include the Figure, Spec, Serial, and Type numbers so proper identification of the pump can be assured.

## 4. PREOPERATION CHECKS

*Read and understand the instructions and recommendations contained in this manual.*

Test the rotation of the driver to make sure it will operate the pump in the desired direction of rotation. Normal rotation is shown on the pump drive end. The driver rotation test must be done with the driver disconnected from the pump so that the motor shaft can be observed. When a relief valve is used, make sure it is positioned and adjusted as discussed in Sections 9 through 11. After the unit is mounted and the piping is connected, the pump should be checked to be sure it operates freely without binding. After operation is proved satisfactory, unit mounting bolts should be tightly secured before operation.

Before starting, make sure the inlet and discharge valves are opened.

After starting the unit, check to see that the pump is delivering liquid. If not, stop the driver immediately and refer to the section on Checking Pump Performance. After the pump is delivering liquid, check the unit for excessive vibration, localized heating, and leakage. Check the pressure or vacuum by installing gauges at both the inlet and discharge sides of the pump to make sure the pressure or vacuum conforms to specifications.

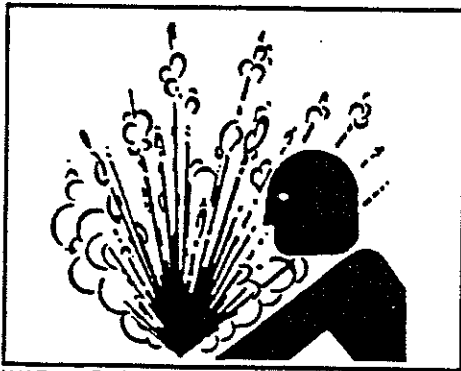

**WARNING!** Do not overpressurize pump or system.

## ! WARNING

If there is no pressure relief device in the system, NEVER block the discharge line. High pressure will occur, resulting in possible damage or breakage to the pump or system parts and possible injury to personnel. Even with a pressure relief device in the system, DO NOT operate the pump for more than one minute with the discharge line blocked. Rapid heating and possible damage will occur. Even an open discharge line does not prevent the possibility of high pressure. Discharge line length, diameter, and arrangement along with fluid viscosity and velocity also can create a high pressure situation at the pump.



## 5. PREPARATION OF FOUNDATION

Locate the pump so that it is as low and as close to the fluid source as practical and so that piping to and from the pump will be as short and simple as practical. The pump and its driver must be accessible for inspection and maintenance. Accessibility to the unit and adequate clearance should be a major thought in any installation. The driver must be suitable for the environment (for example; open, splash proof, totally enclosed, or explosion proof electric motor). If the driver is not suitable, choose a different location or obtain another driver.

For best pump-driver unit life, mount each unit on a strong baseplate with a proper foundation. A good foundation is of major importance to the total installation.

Normal mounting for this pump is horizontal with the pump above the baseplate. Mountings other than described above (such as vertical mounting, wall mounting, ceiling mounting, etc.) may require that special components and precautions be used. Extra pump supports, special drivers, extra anchor bolts may be necessary in unusual mountings. If your application requires other than normal mounting, as described above, you are urged to consult Roper Pump Company for assistance in determining any special needs that may be required.

## 6. ADDITIONAL IMPORTANT WARNINGS AND INFORMATION

### **! WARNING**

**This pump contains strong magnetic fields. Keep away from pacemakers and other medical equipment that is sensitive to magnetic fields.**

- *This manual cannot possibly cover every situation concerning the use, inspection, adjustment, and test of the pump furnished. Roper must presume that the crew using this pump have ample knowledge and training to apply sound safety and operating practices that may not be mentioned.*
- Roper pumps are general purpose pumps for a wide range of uses; yet, *they are not designed nor intended for use with every known substance.* It is, therefore, not practical to include performance or maximum ratings in this manual. Roper sales brochures contain standard ratings for the type of pump involved. If you do not have ratings or performance properties for your pump, they may be obtained by contacting a Roper distributor or Roper Pump Company.
- Review this manual to figure out the proper union of the pump into the total plant or system operating programs.
- *Roper does not supply, recommend, or approve the systems in which its pumps are or may be used.* Unless designed, built, and used properly, systems may be unsafe or dangerous. You should check and comply with all federal, state, local and other regulations and recommendations such as: NFPA, UL, OSHA, API, etc.

In particular, you must check the pumped liquid properties and take proper precautions. Among other things, consider the following:

- Decide the results of spillage or leakage (all pumps or systems may fail sometime).
- |  |   |
|--|---|
| <input type="checkbox"/> Explode       | <input type="checkbox"/> Toxic            |
| <input type="checkbox"/> Corrode       | <input type="checkbox"/> Fire             |
| <input type="checkbox"/> Chemical Burn | <input type="checkbox"/> High Temperature |
| <input type="checkbox"/> High Pressure | <input type="checkbox"/> Other            |

- Are you using proper safeguards?
  - Temperature Controls
  - Pressure Controls
  - Leak Detectors
  - Shutoff Devices
  - High or Low Pressure Safeguards
  - Alarm Devices
  - Overfill or Overflow Detection
  - Driver Overload Controls
  - Consider all possible methods and series of failure.
  - Are any other methods needed to control a hazard?
  - Regular scheduled inspection for the wear and tear of parts.
- Identify all possible hazards. Decide upon and install the required controls. Only you, the user, understand your product and system properties fully. *The ultimate responsibility for the application and safety is with you.*
- Particularly note the chance of fire and burns from flammable or hot liquid spillage from burst hoses and take proper precautions.
- Properly guard all exposed rotating parts.
- Install a pressure relieving device in the system discharge piping to protect the equipment and crew from accident due to too much pressure. Read Section 4 on Preoperation Checks.
- Spillage or overflow, from overfilling or putting too much pressure on any component of a system incorporating this pump, may result in an accident. Proper measures and precautions must be taken to avoid spillage or overflow from overfilling or putting too much pressure on any component of the system. This includes the receiver and lines.
- **WARNING! NEVER** allow magnet sets to be closer than two feet from each other or to other ferrous materials when pump is disassembled. These magnet sets are extremely powerful and serious injury and/or equipment damage could result if proper procedures are not followed. **DO NOT** attempt to disassemble or assemble pump without reading and understanding the installation and operating instructions.
- Roper continually updates its manuals; therefore, you should periodically request an updated copy or check that you have the latest edition.

Prior to starting pump, read sections on Preparation of Foundation; Installation of Pipes; Threaded Port Connections; and Preoperation Checks. These sections may be found elsewhere in this book.

---

## 7. INSTALLATION OF PIPES

Piping must be installed and checked carefully. Allow for any expansion or contraction.

Any external force or moment (torque or twist) applied on the pump ports by the piping will cause stresses in the pump and its foundation. This may cause misalignment that could result in heating, noise, or excessive vibration. Such forces or moments may be caused by improperly aligned piping or by thermal expansion of the piping when pumping hot or cold fluids. The piping should be supported independently of the pump. Use flexible piping connectors and insure that they are properly anchored.

If an expansion joint is installed in the piping between the pump and the nearest point of anchor in the piping, a force equal to the area of the expansion joint (which may be considerably larger than the normal pipe size) times the pressure in the pipe will be transmitted directly to the pump. Pipe couplings that do not provide an axially rigid connection have the same effect. This reaction force can be so large that it would be impractical to design suitable components to withstand the force. If an expansion joint or nonrigid coupling is used, install a pipe anchor between it and the pump. If properly installed, this will eliminate the forces mentioned above.

The pump port size does not necessarily establish the correct pipe size. Piping must be sized and arranged to provide ample inlet pressure at the pump and to insure that the discharge pressure will be at least as low as the rated pressure of the pump. If the fluid to be pumped is viscous, or the piping long, or the suction lift or static discharge head somewhat high, piping one or two sizes larger may be required. Friction losses should be carefully calculated (see Hydraulic Institute Pipe Friction Manual or similar authority for friction loss data) and compared to the pump ratings before the installation is made. Where valves are used in the piping system, gate, ball, or butterfly valves are preferable to globe or angle valves. 90° long radius elbows or 45° elbows are preferable to standard short radius elbows.

Thoroughly clean and flush the piping system before connecting the pump.

---

## 8. THREADED PORT CONNECTIONS

American National Standard Taper Pipe Threads (NPT) are standard for pipe plugs and threaded ports of the pump. British Standard Pipe Threads (BSP) are available on request for most sizes.

To produce a pressure tight joint, a thread sealant must be used. TFE tape is generally not recommended where cast iron is used as one or more parts of the joint. The use of TFE tape for installing cast iron fittings may cause damage to the pump or fittings.

The following is a partial list of sealants that may be used when making up joints on the pump:

- PST Pipe Sealant No. 567 - Loctite Corp.
- Rectorseal No. 5 - The Rectorseal Corp.
- Leak Lock - Highside Chemical, Inc.

Follow the sealant manufacturer's instructions when making up a joint.

**NOTE:** The assembly of NPT and BSP connections without the use of a sealant may cause galling of the threads resulting in damaged parts that may require replacement.

## 9. DIRECTION OF ROTATION

Prior to operating the pump, make sure that the shaft rotation, pipe connections, and faceplate position are in accordance with the following instructions and illustrations shown below.

For inlet pressures over 25 psig [172.4 kPa] consult a Roper distributor or Roper Pump Company, Commerce, Georgia.

PLAIN FACEPLATE: Series V pumps, size 05 through 30, with a plain faceplate can operate in both directions of rotation.

RELIEF VALVE FACEPLATE: All series V pumps with a relief valve faceplate must have the faceplate positioned as shown in the illustrations below.

On a V05, 10, or 20, the relief valve adjusting screw and the pump discharge port must be on the same side of the pump centerline as the discharge port.

On a V30, the relief valve adjusting screw must be on the same side of the pump centerline as the inlet port.

To reverse rotation, remove cap screws and/or nuts (securing faceplate) and faceplate, taking care not to damage O-rings. Turn faceplate 180° and place back on pump. Dowel pins will locate parts in proper position. Tighten cap screw and/or nuts.

ROT	FLANGE MOUNTED PUMP SIZE	
	V05, V10, V20	V30
CW		
CCW		

## 10. RELIEF VALVE

The relief valve must be positioned as shown in instructions for Direction of Rotation; otherwise the valve is inoperable. Discharge pressure will be working against the relief valve.

If the built-in relief valve is used, it is mandatory that the relief valve be set **BY THE USER**, since maximum relief valve pressure depends upon the viscosity and specific gravity of the liquid, the flow rate (pump rpm), and also the initial relief valve setting. If not otherwise specified, the relief valve on this pump is factory set for full bypass at a differential pressure of 150 psig [1034.2 kPa], at a pump speed of 1800 rpm, on liquid with a viscosity of approximately 150 SSU (28 cSt). This setting would only apply if all those conditions are duplicated.

**NOTE:** The fact that the pump has the correct rotation and discharges liquid through the desired ports **DOES NOT** insure that the relief valve is installed in the correct position, or that it has the correct setting for the application.

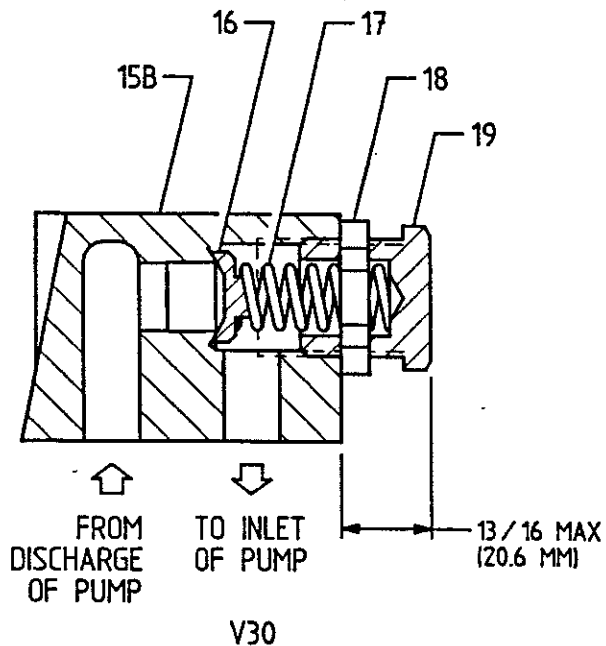
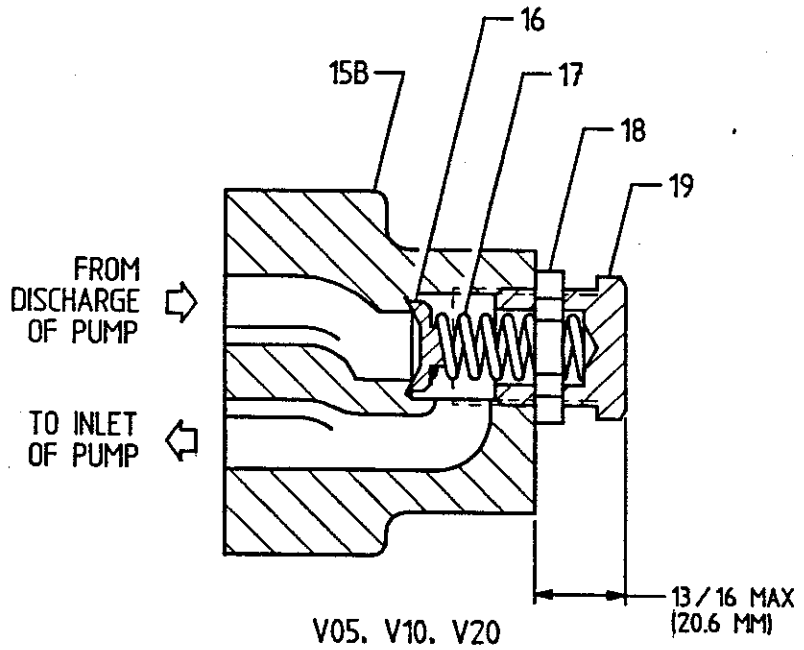

---

## 11. RELIEF VALVE ADJUSTMENT

- **WARNING!** Take necessary precautions to prevent personal injury and/or physical damage that could be caused by any loss of the product being pumped while adjusting the relief valve.

Relief valve must be adjusted under conditions identical to the operating conditions. (viscosity, rpm, etc.)

1. Connect a pressure gauge near the pump in the discharge line between the pump and the point where the discharge line will be closed.
2. Loosen the sealing nut (18) on the adjusting screw (19).
3. Back the adjusting screw (19) out to the point where the end of the adjusting screw will be 13/16 of an inch maximum [20.6 mm] from the faceplate as shown on the relief valve drawing on page 11.
4. Start the pump and close the discharge line slowly. **DO NOT** exceed pressure rating of pump or other equipment between pump and discharge line valve. If this pressure is reached while closing the discharge valve, **DO NOT** close any further. (This might occur with very viscous liquids.) It would then be necessary to install a separate relief valve in the system for protection. **DO NOT** run pump with closed discharge line for more than one minute at a time. If proper adjustment cannot be obtained in one minute, open the discharge valve and let liquid flow for one minute, then continue with adjustment.
5. With discharge valve closed, turn adjusting screw (19) clockwise in 1/2 turn increments until the pressure gauge shows the desired pressure setting.
6. Open discharge line and turn pump off.
7. Tighten sealing nut (18).

Relief valve is now set at desired settings.

---

## 12. RELIEF VALVE DISASSEMBLY

- **WARNING!** Before starting disassembly, be sure there is no residual pressure in the system.
  - **WARNING!** Take necessary precautions to prevent personal injury or physical damage that could be caused by spillage of the product trapped in the pump while adjusting screw (19) is removed.
1. Shut off pump and close the inlet and discharge lines.
  2. Loosen the seal nut (18) on the adjusting screw (19). Remove the adjusting screw (19) by unscrewing it from the faceplate (15B).
  3. Remove spring (17) and poppet (16).
  4. Visually inspect parts. Replace all worn or damaged parts before reassembling relief valve.

## 13. RELIEF VALVE ASSEMBLY

1. Read sections on Replacement Parts and Safety Precautions before reassembling relief valve. Visually inspect all parts during assembly. Replace all worn or damaged parts.
2. Install poppet (16) and spring (17) into faceplate (15B) making sure that the spring (17) is centered on poppet (16) and that the poppet is sitting properly on the seat. See Section 10 for proper parts orientation.
3. Install adjusting screw (19) into position and adjust to desired setting. (See Section 11 on Relief Valve Adjustment.)
4. Tighten seal nut (18).

A built-in relief valve should not be used on applications where the discharge must be closed for more than one minute. Prolonged operation with the relief valve fully bypassing will cause heating of the liquid circulating through the valve, thus resulting in possible damage.

For inlet pressure over 25 psig [172.4 kPa], Consult a Roper distributor or Roper Pump Company, Commerce, Georgia.

## 14. INSTRUCTIONS FOR PUMP DISASSEMBLY

### **! WARNING**

**This pump contains strong magnetic fields. Keep away from pacemakers and other medical equipment that is sensitive to magnetic fields.**

Refer to the appropriate sectional drawing in Section 16.

1. Read sections on Safety Precautions and Additional Important Warnings and Information before starting to disassemble pump. While disassembling pump, always inspect disassembled parts and adjacent parts to see if further disassembly is needed. Replace worn or damaged parts as required. Read section on Replacement Parts.
2. Turn off pump and lock out energy source to driver. **DO NOT** proceed with disassembly of the pump if there is the slightest possibility that the driver may be started.
3. Close inlet and discharge lines.
4. Drain inlet and discharge lines. Disconnect lines from pump inlet and discharge.
5. It is recommended that a clean work area and surface be provided when disassembling the pump. The strong magnets in this pump will pick up loose ferrous particles and tools that are several inches away.
6. Remove four cap screws (E) securing backplate (10) to bracket (26). Using two 5/16-18 UNC x 2.5 inch long jackscrews (J) in holes provided in backplate (10), jack backplate (10) from bracket (26).
  - **WARNING! DO NOT** attempt to disengage or engage the magnetic rotors without the use of jackscrews. Personal injury and/or equipment damage could result. **NEVER** allow the inner and outer magnetic rotors to be closer than two feet from each other when pump is disassembled. These magnets are very strong and must be handled carefully to prevent personal injury and/or equipment damage.
7. Remove six cap screws (F) securing containment barrier (21) to backplate (10). Using a soft face striking tool, gently tap containment barrier (21) to break seal of containment barrier to backplate.

8. Remove o-ring (20) from backplate (10).
9. Remove retaining ring (24A) holding inner magnetic rotor (23) on drive shaft (11). Remove inner magnetic rotor (23).
10. Remove drive key (A).
11. Remove retaining ring (24B) from drive shaft (11).
12. Remove four cap screws (H) securing faceplate (15A, B) and case (13) to backplate (10).
13. If disassembly of relief valve faceplate (15B) is required, refer to Section 12 covering Relief Valve Disassembly.
14. Remove faceplate (15A, B) from dowel pins (G) in case (13).
15. Remove case (13) from dowel pins (G) in backplate (10).
16. Remove dowel pins (G) from case and backplate.
17. Remove one o-ring (14) from each side of case (13).
18. Remove idler gear and shaft (12).
19. Remove drive gear and shaft (11).
20. Remove four cap screws (B) securing bracket (26) to motor.
21. Loosen setscrews (C) securing outer magnetic rotor (22) to motor drive shaft. Remove outer magnetic rotor (22). **NEVER** allow the inner and outer magnetic rotors to be closer than two feet from each other when pump is disassembled. These magnets are very strong and must be handled carefully to prevent personal injury and/or equipment damage.
22. Visually inspect all parts. Replace all worn or damaged parts before reassembling pump. It is recommended that new o-rings (14, 20) be installed each time pump is disassembled and reassembled.

## 15. INSTRUCTIONS FOR PUMP ASSEMBLY

### **! WARNING**

This pump contains strong magnetic fields. Keep away from pacemakers and other medical equipment that is sensitive to magnetic fields.

1. Read sections on Replacement Parts and Safety Precautions before reassembling pump. Visually inspect all parts during assembly. Replace all worn or damaged parts. Although they may appear reusable, it is recommended that new o-rings (14, 20) be installed when the pump is being reassembled.
2. Install two dowel pins (G) in appropriate holes on backplate (10).
3. Install one o-ring (14) on each side of case (13). Position case (13) on dowel pins (G) installed in backplate (10).
4. Install drive gear and shaft (11) and idler gear and shaft (12).



5. Position faceplate (15A,B) on the drive gear and shaft (11) and idler gear and shaft (12) installed in case (13). Refer to Section 9 and 10 for proper relief valve orientation. Install two dowel pins (G) in appropriate holes in faceplate (15A,B) and tap in. Secure case (13) and faceplate (15A,B) to backplate (10) using four cap screws (H). If assembly of relief valve faceplate (15B) is required, refer to Section 13 on Relief Valve Assembly.
6. Install retaining ring (24B) on drive shaft (11).
7. Install drive key (A).
8. Slide inner magnetic rotor (23) on drive shaft (11). Secure inner magnetic rotor to drive shaft using retaining ring (24A). **NEVER** allow the inner and outer magnetic rotors to be closer than two feet from each other while pump is disassembled. These magnets are very strong and must be handled carefully to prevent personal injury and/or equipment damage. **CAUTION!** Be sure all foreign matter is removed from inner magnetic rotor.
9. Install o-ring (20) in groove in backplate (10).
10. Position containment barrier (21) on pilot diameter of backplate (10). Secure containment barrier in place using six cap screws (F) making sure not to damage o-ring (20).
11. Slide outer magnetic rotor (22) on motor shaft. Measure from face of motor 3.9/3.94 inches [99/100 mm] to face of outer magnetic rotor (22). Tighten the setscrews (C) to secure outer magnetic rotor (22) on motor shaft.
12. Secure bracket (26) to face of motor using four cap screws (B).
13. Screw the two 5/16-18 UNC x 2.5 inch long threaded jackscrews (J) the entire length into backplate (10). Slowly begin to back jackscrews (J) out of backplate (10) allowing inner magnetic rotor (23) which is enclosed in containment barrier (21) to engage in outer magnetic rotor (22). Secure bracket (26) to pump using four cap screws (B).
14. Read sections on Additional Important Warnings and Information, Threaded Port Connections, Installation of Pipes, and Preoperation Checks before installing and operating pump.

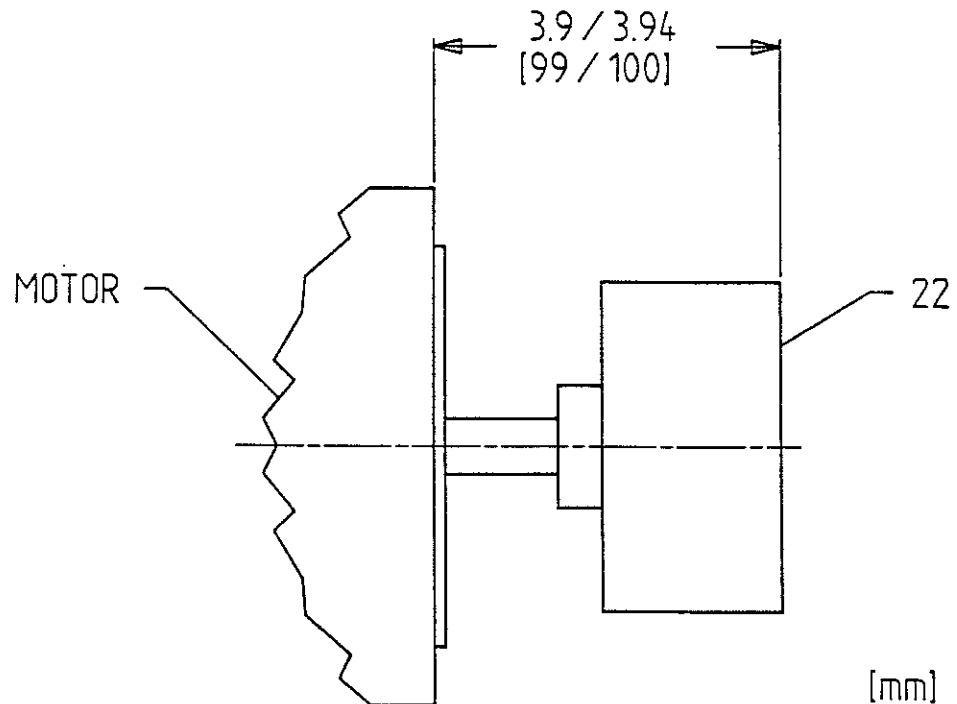

# 16. PUMP SECTIONAL DRAWINGS

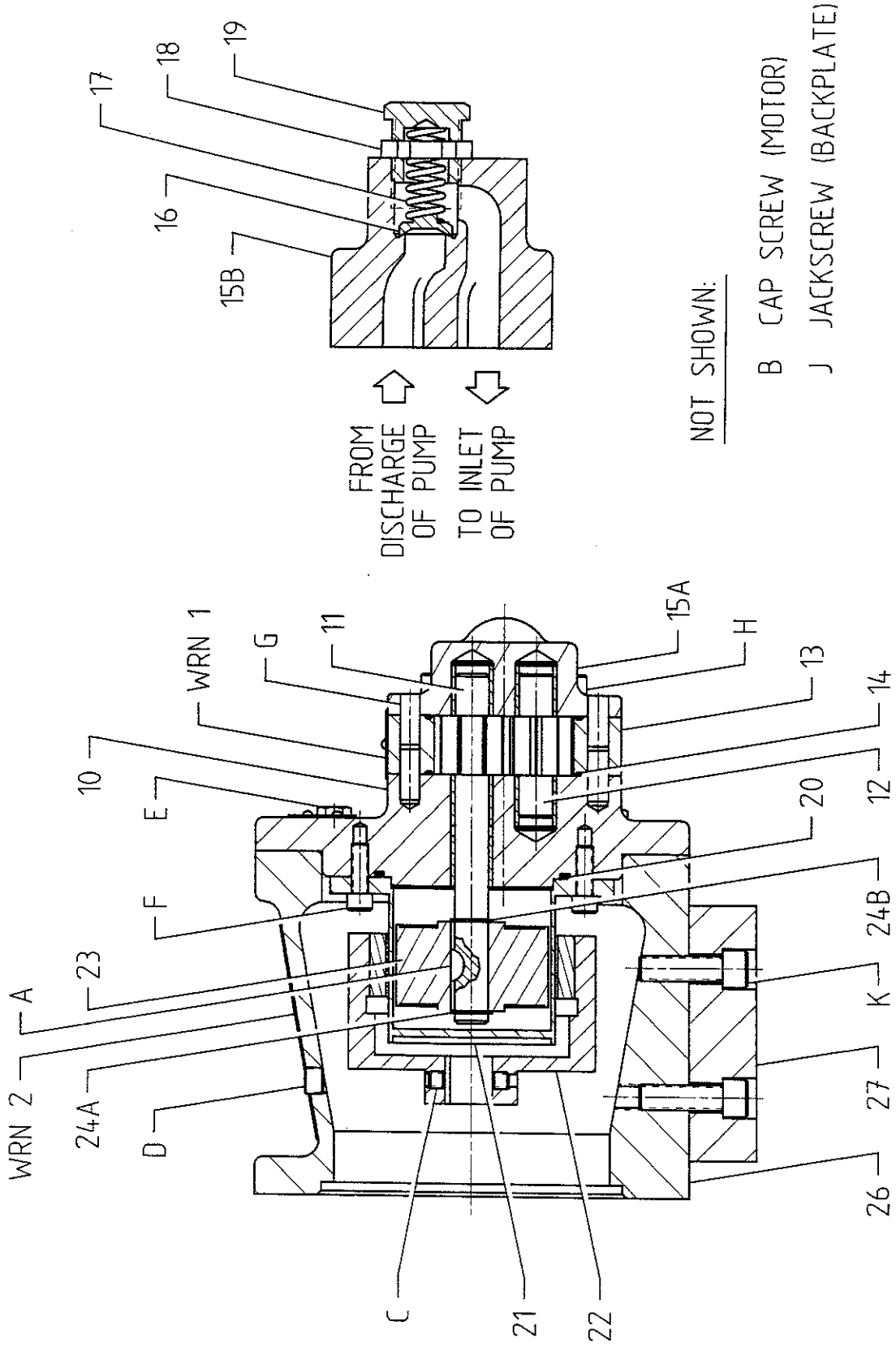

NOT SHOWN:

- B CAP SCREW (MOTOR)
- J JACKSCREW (BACKPLATE)

VO5, V10, V20

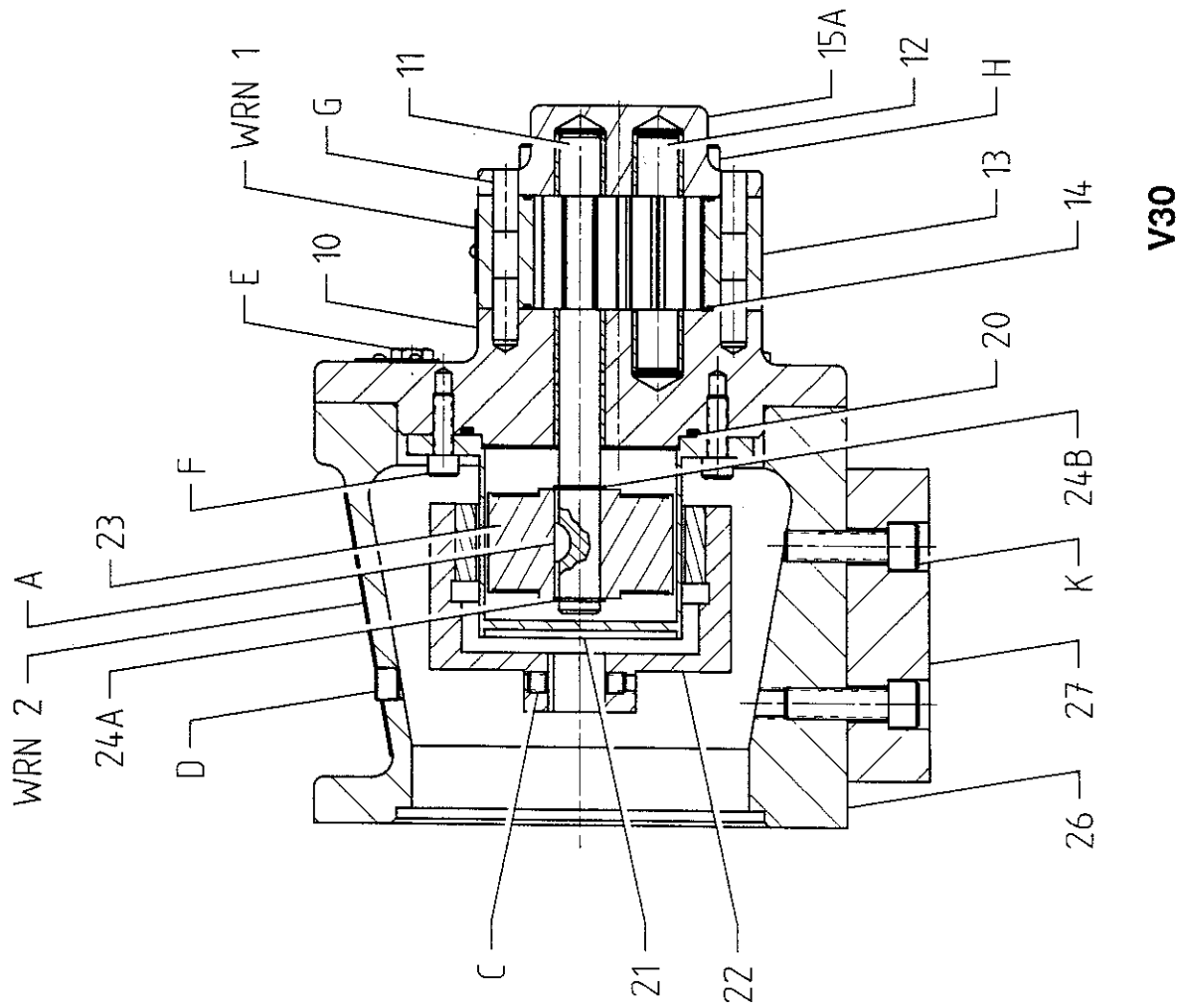
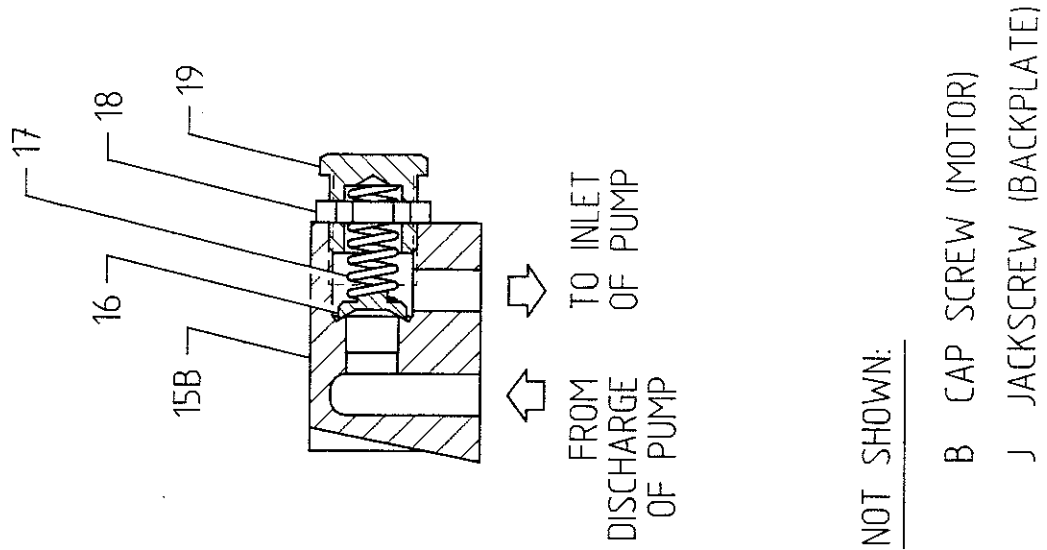

V30

---

**17. PARTS LIST**

- |                          |   |
|--------------------------|---|
| 10. Backplate            | 24. Retaining Ring                              |
| 11. Drive Gear and Shaft | A. Outer  |
| 12. Idler Gear and Shaft | B. Inner  |
| 13. Case                 | 26. Bracket                                     |
| 14. O-Ring               | 27. Foot, Bracket                               |
| 15. Faceplate            |   |
| A. Plain                 | A. Drive Key                                    |
| B. Relief Valve          | B. Cap Screws (bracket to motor)                |
| 16. Poppet               | C. Setscrews                                    |
| 17. Spring               | D. Pipe Plug (bracket)                          |
| 18. Seal Nut             | E. Cap Screws (bracket to pump)                 |
| 19. Adjusting Screw      | F. Cap Screws (canister barrier to backplate)   |
| 20. O-Ring, Backplate    | G. Dowel Pins                                   |
| 21. Containment Barrier  | H. Cap Screws (faceplate and case to backplate) |
| 22. Outer Magnetic Rotor | J. Jackscrew                                    |
| 23. Inner Magnetic Rotor | K. Cap Screws (foot to bracket)                 |

## 18. CHECKING PUMP PERFORMANCE

A summary of the causes of common malfunctions.

PROBLEM	POSSIBLE CAUSES
NO LIQUID DELIVERED	Pump not primed.
	Pump rotating in wrong direction.
	Inlet lift too high. Check this with gauge at pump inlet.
	Clogged inlet line.
	Inlet pipe not submerged.
	Air leaks in inlet line.
	Faulty pressure relief device in system.
	Pump worn.
Magnetic coupling slipping.	
RAPID WEAR	Excessive pressure.
	Pump runs dry.
	Incompatibility of liquid and pump materials.
	Pipe strain on pump. See Installation of Pipes.
	Nonlubricating liquid.
Abrasive in liquid.	
EXCESSIVE NOISE	Starved pump.
	Air leaks in inlet line.
	Air or gases in liquid.
	Pump speed too high.
	Relief valve chatter. Check pressure setting.
	Improper mounting. Check alignment thoroughly. See Aligning Driver and Pump and Preparation of Foundation.
Magnetic coupling slipping.	
PUMP TAKES TOO MUCH POWER	Speed too high.
	Liquid more viscous than previously anticipated.
	Operating pressure higher than specified. Check this with gauge at pump discharge.
	Discharge line obstructed.
	Mechanical defect.
	Pipe strain on pump. See Installation of Pipes.
	Pressure relief device in system not operating properly.

PROBLEM	POSSIBLE CAUSES
INSUFFICIENT LIQUID DELIVERED	Air leaks in inlet line.
	Speed too slow.
	Excessive lift at inlet. Check this with gauge at pump inlet.
	Viscosity of liquid too high for size and length of inlet pipe.
	Foot valve or end of inlet pipe immersed deeply enough in liquid.
	Pump damaged by misalignment or foreign matter.
	Excessive clearance in pump caused by wear or corrosion.
	Faulty pressure relief device in system.
	Partial air pockets or vapor lock.
	Magnetic coupling slipping.