

CECO Fybroc



PUMP SUPPLY
INCORPORATED

Fybroc® series 1530 horizontal pumps

INSTALLATION MANUAL

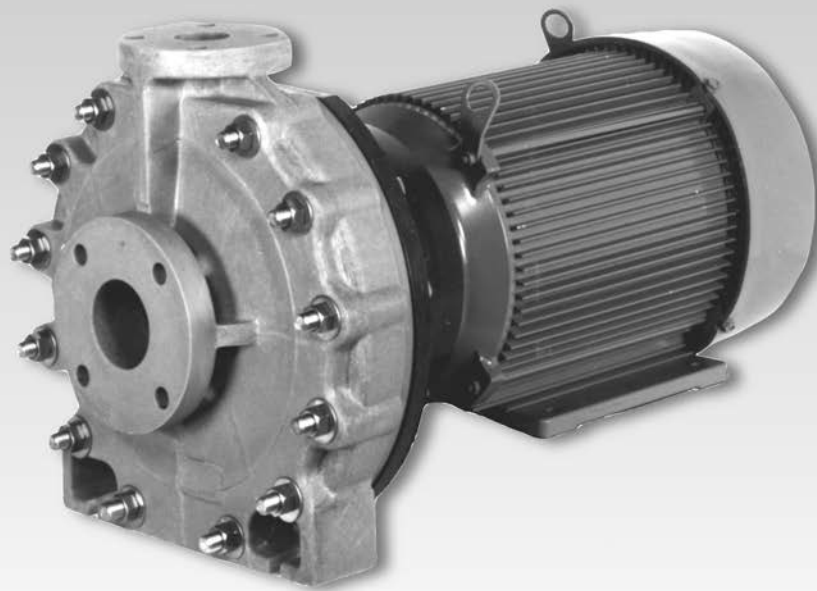

INDEX

	Page		Page
Fybroc Warranty	3	Assembly	10
Installation Instructions	4	John Crane Type 8B2	10
Location	4	John Crane Type 8-1T	11
Foundation	4	John Crane Type 8-D	12
Piping the Pump	4	Impeller Adjustment	13
Suction Piping	5	Operational Start-up Checklist	14
Discharge Piping	5	Sectional Drawings	15
Ancillary Piping	5	1530 Group I	15
Electrical Connections	6	1530 Group II	16
Start-up and Operating Procedures	7	Typical Mechanical Seal Installations	17
Lubrication	7	Product Flush	17
Seal Flushing	7	External Flush	18
Mechanical Seals	7	Mechanical Seal Piping/Flow Requirements	19
Priming	7	Single Mechanical Seal	19
Starting	7	Double Mechanical Seal	20
Operational Check List	7	Notes	21
Maintenance	7		
Motor	7		
Trouble Check List	8		
Assembly/Disassembly Procedures	9		
General	9		
Disassembly	9		

ORDERING REPLACEMENT PARTS

For future reference fill in the following information from the pump nameplate. This will be necessary to ensure accuracy when ordering replacement parts.

Model _____
 Size _____
 Serial Number _____
 Impeller Diameter Installed _____
 Seal Type _____
 Material of Construction _____

CECO Fybroc

WARRANTY

FYBROC pumps are warranted by the Company, insofar as the same are of its own manufacture, against defects in materials and workmanship under proper and normal use and service, for a period of one year from the date of original shipment from the factory. FYBROC's obligation is limited, however, to furnishing without charge, F.O.B. its factory, new parts to replace any similar parts of its own manufacture so proving defective within said period, provided the Buyer has given FYBROC immediate written notice upon discovery of such defect. No allowance will be made for labor charges. FYBROC shall have the option of requiring the return of the defective material, transportation prepaid, to establish the claim.

FYBROC makes no warranty or guarantee whatsoever, either express or implied, of prime mover, starting equipment, electrical apparatus, parts or material not manufactured by Fybroc, except to the extent that warranty is made by the manufacturer of such equipment and material.

FYBROC assumes no liability for damages or delays caused by defective material, and no allowance will be made for local repair bills or expenses without the prior written approval or authority of FYBROC.

Under no circumstances will FYBROC be liable for indirect, special or consequential loss or damage of any kind and the Buyer assumes all liability for the consequences of its use or misuse by the Buyer, his employees, or others.

PERFORMANCE GUARANTEE

Is at the specified point of rating only and will not cover performance under conditions varying therefrom, nor for sustained performance over any period of time.

ACCEPTANCE TESTS

If required, shall be conducted in accordance with the practices as set forth in the Hydraulic Institute Standards. The expense of any such tests shall be borne by the buyer.

PERFORMANCE REPRESENTATIONS

Are based on shop laboratory tests with cold water as outlined in the Hydraulic Institute Standards.

FIELD TESTING

Due to the inaccuracies of field testing, the results of any such tests conducted by or for the Buyer shall be interpreted as being only indicative of the actual field performance of the pump. No equipment will be furnished on the basis of acceptance by results of field tests. If the buyer, after such a test, questions the performance of the pump, he may at his option request a test to establish the performance. Such tests will be conducted in accordance with the above paragraph entitled "Acceptance Tests."

ALL WARRANTIES

Are void if -

- a. Pipe strains are the cause of damage.
- b. Pump handles liquids other than those specified in detail.
- c. NPSH lower than required by pump impeller.
- d. Operating speed is higher than specified.
- e. Improper field installation.

RECOMMENDATIONS FOR SPECIAL MATERIALS

To combat corrosion, abrasion, erosion, or pumping solids, foreign objects, or pumping liquids at elevated temperature, any such recommendations will be based on the best available experience of FYBROC and the supplier of the material and industry, BUT WILL NOT CONSTITUTE A GUARANTEE AGAINST THESE EFFECTS.

The foregoing warranty is made in lieu of all other warranties, guarantees, obligations or liabilities, expressed or implied, by FYBROC or its representatives. All statutory or implied warranties, other than of title, are hereby expressly negated and excluded.

All illustrations and provisions in specifications are descriptive and are not intended as warranties. Penalty of any kind are not acceptable unless approved in writing by an officer of Met-Pro Corporation.

INSTALLATION HORIZONTAL PUMPS

LOCATION

The pump should ideally be placed as close as possible to the liquid supply source. Allow sufficient space on the sides and overhead to permit inspection and maintenance work to be performed.

FOUNDATION

The foundation for the pump should be level, provide rigid support of pump and motor. It should also be of sufficient mass to dampen any vibrations developed. Typically this is accomplished by installing and grouting a Fibroc baseplate on a concrete foundation.

Foundation bolts of the proper size should be imbedded in the concrete with anti-rotation lugs, located by a drawing or template (See Table 1 below for bolt-size and locations). A pipe sleeve larger than the bolt should be used to allow enough lateral movement for final positioning of the bolts (See Figure 1 below). Leveling wedges or shims should be placed under the sides of the baseplate to level the unit and the foundation bolts slightly tightened.

A wood form can now be built around the edge of the baseplate to contain the grout. The top of the rough concrete foundation should be wetted down prior to grouting. A good grade of non-shrinking grout can now be packed through the open end of the fiberglass baseplate. Once the grout has fully hardened, usually about 48 hours after pouring, the foundation bolts can be fully tightened.

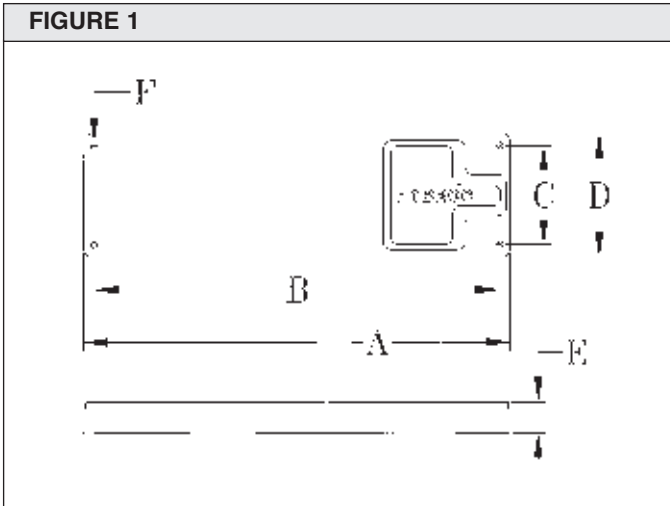
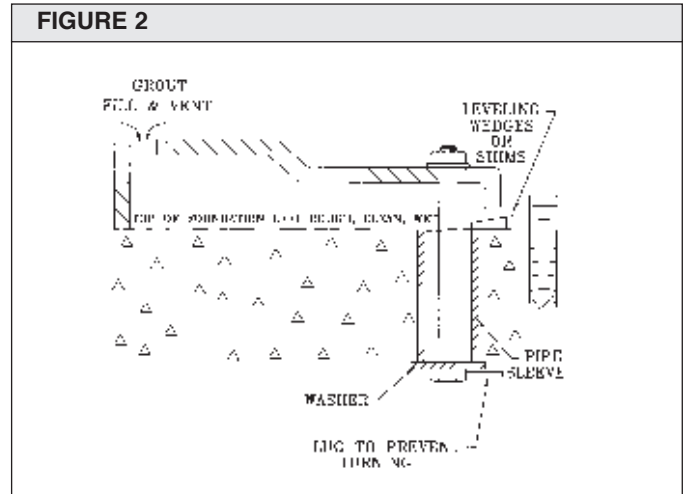

PIPING THE PUMP

All flanged connections to the pump should be full flat face with full contact gaskets. Raised face flanges or partial contact gaskets should not be used as excessive strains can be applied to the pump flanges upon tightening.

The pump has been designed with all necessary strength factors for long, reliable service life. However, due to the composite construction, care must be taken during installation to avoid unnecessary pipe strain. If severe piping strains are to be encountered, flexible connections are recommended in the suction and discharge pipe lines. When lined piping is used, flange alignment should be carefully checked. Spacer ring gaskets are recommended to assure parallel alignment of pipe and pump flanges. The following flange bolt torque values should be used:

Base Plate	A	B	C	D	E	F	Bolt Size
1T-22"	22	19 1/2	8	8	2 5/8	3/4	1/2
1T-24"	24	21 1/2	9	8	2 5/8	3/4	1/2
2T-30"	30	27 1/2	9	9	2 7/8	3/4	1/2
3-21"	21	18 1/2	12	7 1/2	3 3/4	3/4	1/2
3-22"	22	19 1/2	15	7 1/2	4	1	3/4
3-27"	27	24 1/2	15	7 1/2	4	1	3/4
3-29"	29	26 1/2	19	7 1/2	4	1	3/4
3-32"	32	29 1/2	19	7 1/2	4	1	3/4

Flange Size	Bolt Torque
1"	9-12 ft-lbs.
1 1/2"	9-12 ft-lbs.
2"	18-24 ft-lbs.
3"	23-30 ft-lbs.
4"	27-36 ft-lbs.
6"	35-50 ft-lbs.

All piping must be supported independently of the pump. The piping should always line up naturally with the pump flanges. Never draw the piping to the suction or discharge flanges of the pump. Outside installations should be properly compensated for changes in ambient temperatures. Refer to pipe manufacturers standards for proper installation. Omission of this could result in severe strain transmitted to the pump flanges.

The piping should be as short and direct as possible. Avoid all unnecessary elbows, bends and fittings, as they increase friction losses in the piping.

SUCTION PIPING

- A) To minimize friction loss, the length of the suction pipe (from process to pump inlet) should be as short as possible. It is important that NPSH available to the pump is greater than the NPSH required by the pump, long suction runs greatly affect NPSH and should be considered carefully. See pump performance curve for NPSH requirements.
- B) The diameter of the suction pipe should be as large as the pump suction. If long suction runs are encountered, the suction pipe diameter should be increased to reduce the NPSH required.
- C) Increases or reducers, if used, should be eccentric and installed with the eccentric side on the bottom of the pipe to prevent air traps.
- D) Elbows, fittings, valves or expansion joints should be avoided at the suction flange. Allow a straight run of at least 10 pipe diameters into the suction of the pump.
- E) If a valve is to be installed in the suction piping, only full flow valves offering a minimum flow disturbance should be used (ball, plug types). These valves should be for shut-off only when the pump is not running, and not for throttling or controlling flow. Centrifugal pumps should never be throttled on the suction side.
- F) Provisions for a suction pressure gauge should be included.

DISCHARGE PIPING

- A) Installation of a valve in the discharge line that can be used as a block for inspection and maintenance is recommended. It should be of a design to allow throttling or flow control.
- B) The diameter of the discharge pipe should be as large or larger than the pump discharge.
- C) Provision for a discharge pressure gauge should be included.

ANCILLARY PIPING

- A) The diameter of the ancillary or seal piping should be large enough to meet the seal flushing requirements. Typically this is 1/4-1/2 GPM at a pressure of 15-25 PSI above the suction pressure for most mechanical seals. Refer to pages 25 and 26 for recommended seal flush flow rates and piping installations.
- B) Where the ancillary piping is connected to the pump only plastic fittings shall be used.

WARNING: FAILURE TO USE PLASTIC FITTINGS MAY RESULT IN DAMAGE TO THE PUMP.

- C) Many modern flush systems incorporate electrically actuated solenoid valves to conserve and control the flow of flush liquids, ensure that the flush liquid is flowing to the seal before the pump is started.
- D) On double seal arrangements with flush in and flush out connections, flow control valves should be installed in the flush out or downstream side.

The pump shaft should turn freely by hand after the piping has been connected to the pump. This is to insure that the piping has not caused binding in the pump. If binding occurs, check for cause and correct.

ELECTRICAL CONNECTIONS

- A) All electrical work done to the unit should be done by a qualified electrician. All local, state and federal electrical codes should be adhered to.
- B) Wire motor according to motor manufacturers instructions. Ensure that all connections and covers are tight and that proper sized wire and switch-gear are used.
- C) All pumps operate in a clockwise direction when viewed from the motor end, (see direction arrow on the pump motor adapter). Connect electric motor to power supply and jog motor to check rotation. If motor is operating in wrong direction, reverse leads and recheck.

WARNING: DO NOT START PUMP WITH LIQUID IN THE CASING UNTIL MOTOR ROTATION HAS BEEN DETERMINED AS DAMAGE COULD RESULT FROM SUSTAINED REVERSE ROTATION UNDER PUMPING LOAD.

START-UP AND OPERATING PROCEDURES

LUBRICATION

On a close coupled pump only the motor requires lubrication. Since all motors come from the factory pre-lubricated there is no action required.

SEAL FLUSHING

Mechanical Seals

Do not operate the pumps without liquid to the mechanical seal. Depending on the flush arrangement of the pump, the fluid to the seal may be piped from the pump discharge externally or internally, or from an external clean source. If the pump is fitted with an internal or bypass flush arrangement, then the pump must be flooded with liquid prior to starting to ensure that the mechanical seal is lubricated. If the pump is equipped for an external flush system, then flush liquid must be supplied to the seal prior to starting. Proper flow for external flushing will vary from 1/4 to 1/2 GPM at a pressure of 15 to 25 PSI above the stuffing box pressure.

PRIMING

Suction valve must be fully open. The pump casing and suction pipe must always be full of liquid before the pump is started. Centerline discharge designs are self-venting therefore the discharge valve should be opened to release any air trapped in the pump and then left slightly open at start-up.

STARTING

Prior to starting, turn pump shaft by hand to be sure rotating elements are free. If it rubs or binds:

- A) Check for piping strains on casing flanges, or other loads on casing.
- B) Check impeller clearance.
(See impeller adjustment).

Prior to starting pump recheck installation procedures with the operational start-up checklist found on page 14 of this manual.

Start pump and bring up to speed, open discharge valve to the rated flow.

WARNING: DO NOT RUN PUMP WITH A CLOSED DISCHARGE VALVE AS THE LIQUID IN THE PUMP WILL RAPIDLY INCREASE IN TEMPERATURE, POSSIBLY CAUSING DAMAGE TO PUMP.

Check flush water to mechanical seal, if not lubricated from the pump discharge.

OPERATIONAL CHECK LIST

- A) Periodically check mechanical seals for proper operation.
- B) Periodically check lubrication to the motor bearings.
- C) Periodically check for excessive vibrations. Correct if necessary.

MAINTENANCE

Fybroc pumps are designed for a long service life. The only scheduled maintenance items are the lubrication intervals for the motor. Please refer to the lubrication procedures given below.

MOTOR

The motor relubrication intervals are greatly influenced by the environment it is in and the length of time it runs. Refer to the following chart for typical relubrication values for motors. Standard duty is when the motor is operated eight hours a day and the environment is free from dust. Severe duty is when the motor runs twenty-four hours per day with exposure to dirt and dust.

Sync RPM Range	Motor Frame Range	Type of Service	
		Standard Duty	Severe Duty
3600	143JM - 256JM	5 Yrs	3 Yrs
	284JM - 286JM	1 Yr	4 Mos
	324JM - 365JM	9 Mos	3 Mos
1800	143JM - 256JM	7 Yrs	3 Yrs
	284JM - 326JM	4 Yrs	1.5 Yrs
	364JM - 365JM	2.5 Yrs	10 Mos
1200	143JM - 256JM	7 Yrs	3 Yrs
	284JM - 326JM	4 Yrs	1.5 Yrs
	364JM - 447JM	3 Yrs	1 Yr

Instructions For Lubricating Motors

Before greasing, be sure fittings are clean and free from dirt. Remove grease relief plug or plate and using a low pressure grease gun pump in the required grease. Do not over-grease. After re-lubricating allow motor to run for an hour before replacing relief hardware.

TROUBLE CHECK LIST

Refer to the following diagnostic section if hydraulic problems are encountered in the pump operation.

PROBLEM: Not enough liquid, or no liquid delivered.

CHECK: Suction pipe and /or pump casing not filled with liquid.

Speed too low.
(Result, reduced TDH).

Suction lift too high or insufficient NPSHA. (Cavitation).

Impeller or suction pipe plugged with solids.

Wrong rotation.
(Result, reduced TDH).

Air pockets in suction line or air leaking in through packing box area.

Suction strainer plugged, if used in suction line.

PROBLEM: Not enough pressure.

CHECK: Speed too low.

Air or gases in the liquid.

Check impeller diameter.

Mechanical defects (impeller clearance too great; impeller damaged).

Wrong rotation.

Pressure gauge in a poor location.

PROBLEM: Pump runs but intermittently pumps liquid.

CHECK: Suction line leaks.

Stuffing box leakage of air.

Air pocket in suction line.
Insufficient NPSH.

Air or gases in liquid.

PROBLEM: Pump takes too much power.

CHECK: Speed too high.

Head lower than rating; pumping beyond design point.

Liquid heavier than specified; check viscosity and specific gravity.

Mechanical defects (Bent shaft, rotating element binds, packing too tight, misalignment).

ASSEMBLY/DISASSEMBLY PROCEDURES FOR HORIZONTAL PUMPS

GENERAL

The Fybroc pump is designed for easy inspection and service because of its back pullout construction. For inspection or replacement of certain parts, the work can be done in place, without the necessity to remove the complete pump to a maintenance area. Refer to applicable Sectional Drawing in this manual for item numbers mentioned below.

Before any work is done the following procedures and precautions should be taken:

- 1) The electric motor should be either disconnected from its power source, or the switch or circuit breaker must be secured in an "off" position so that the motor cannot be accidentally started.
- 2) Depending upon the fluid being pumped, the proper protective equipment should be worn (gloves, mask, respirator, goggles or safety glasses, etc.) to prevent contact with the fluid in the pump or pipelines.
- 3) Check the valves on the suction and discharge lines to be sure they are closed and secured.
- 4) If the mechanical seal is flushed from an external source, turn off the valve in the supply line and disconnect the flush line.
- 5) The liquid trapped in the pump and piping should be drained. Care should be taken to either trap the fluid in a container or to divert it to a proper disposal area so that the area around the pump and base will not be contaminated.

DISASSEMBLY

- 1) If the complete pump is to be removed to a maintenance area, remove the bolts holding the motor and casing to the baseplate. Remove the bolts on the suction and discharge flange connections. Now the whole pump can be removed. If the casing is to be left in place remove the screws holding the motor to the baseplate and then remove the casing bolts, nuts, washers and shims securing the casing to the cover and motor adapter (Items 1C, 1D, 1E, 67). Now the rotating assembly can be pulled away from the casing and removed. Note the number of shims removed. Two jackscrews (Item 19D) are provided to ease disassembly.
- 2) If the casing was removed with the pump, remove the casing bolts, nuts, washers and shims securing the casing to the cover and frame adapter (Items 1C, 1D, 1E, 67). The rotating assembly can be pulled away from casing. Note the number of shims that were removed. Two jackscrews (Item 19D) are provided to ease disassembly. Now the pump can be placed in a convenient location to disassemble it.
- 3) Remove the cover o-ring (Item 73) and place in a container with the casing hardware.
- 4) To disassemble the impeller assembly, remove the locking ring (Item 14 B) by removing the two Allen head screws, thus exposing the segment key (Item 14A), which can now be removed from the impeller sleeve.
- 5) If the pump is provided with a mechanical seal utilizing set screws to drive the seal, loosen the set screws. If the mechanical seal is of the preset outside type, reinstall the seal setting clips, prior to loosening the set screws.
- 6) Remove rear fan cover from motor; use vise grips or pipe wrench to hold rear motor shaft extension from turning. Remove fan if required. Do not attempt to hold fan. The impeller assembly can now be removed by turning the impeller in a counter-clockwise direction facing the impeller. A strap wrench or similar device may be required to disengage the screw threads. The impeller, stuffing box cover, and seal can now be removed as a unit.
- 7) If the mechanical seal is a single outside seal be sure the set screws are loose and pull the rotary seal assembly off the sleeve, using a twisting motion as it is removed. The impeller (Item 2) can be removed from the cover. Remove the four bolts and washers (Item 17C, 17E) securing the gland (Item 17) to the cover (Item 11) and remove the gland and then the seal stationary from the cover. The carbon and ceramic elements of the seal should be handled carefully to prevent chipping or scratching.

If the mechanical seal is a double inside seal, remove the four bolts and washers (Item 17C, 17E) securing the gland (Item 17) to the cover (Item 11) and remove the gland. Be sure the set screws are loose, and pull the rotary seal assembly off, using a twisting motion as it is removed. The impeller (Item 2) can be removed from the cover. Next remove the stationary seal faces from the gland and cover by gently pressing them out using your thumbs. The carbon and ceramic elements of the seal should be handled carefully to prevent chipping or scratching.

- 8) The motor shaft adapter (Item 6) may be removed from the motor shaft by removing the Allen head screw (Item 6A). The drive key (Item 46) will slide off with the shaft adapter. In the bore of the shaft adapter there may be some shims to take up the motor manufacturer's shaft length tolerances. Be sure to note the number and thickness of the shims used.
- 9) Remove pump adapter (Item 71) and motor adapter (Item 71B) if provided.

ASSEMBLY

- 1) Inspect casing, cover and impeller for any damage and make sure all sealing surfaces are free of dirt and scratches. If pump is equipped with an internal seal flush, make sure cover flush hole is clear. Check motor end float. Excessive shaft end float (greater than .015") can result in damage to pump and or mechanical seal.
- 2) If equipped install the motor adapter (Item 71B). Ensure that the adapter is seated squarely on the motor before tightening adapter screws, this may require some sanding of the paint on the pilot diameters. Secure with adapter screws (Item 71C), torque to 25 ft-lbs.
- 3) Install the pump adapter (Item 71). Ensure that the adapter is seated squarely on the motor adapter or motor before tightening adapter screws, this may require some sanding of the paint on the pilot diameters. Secure with adapter screws (Item 71A), torque to 25 ft-lbs. end of shaft.
- 4) Place one .062" shim washer (Item 6B) in the shaft (Item 6) bore. Install key (Item 46) into the shaft key-way slot from the inside of the shaft bore. Slide assembly onto motor shaft and temporarily secure with shaft screw (Item 6A).
- 5) Place six impeller adjusting shims (Item 67, three on each side) and the cover (Item 11) on to the pump adapter. Ensure that the cover is seated squarely on the pump adapter, this may require some sanding of the paint on the pilot diameter. Clamp the cover tightly to the adapter with clamps or bolts.
- 6) Thread the impeller (Item 2) onto the shaft adapter until it bottoms on the shoulder of the shaft adapter. Place a feeler gauge between the cover and the balance vanes on the impeller.
- 7) The gauge should read approximately .035", if it does not, repeat steps 4-6 using a different washer or combination of washers until the proper clearance is obtained. Four washers are supplied by Fybroc: 2@.010", 1@.032" and 1@.062" this will provide for 0-.110" worth of shimming capabilities which will adapt to any motor used.
- 8) Once the proper number of shims is determined, remove the impeller, cover and plastic shims and tighten the shaft adapter screw to 35 ft-lbs. for 3/8" screws and 50 ft-lbs. for 1/2" screws.
- 9) Place some anti-seize lubricant on the shaft adapter impeller threads.
- 10) The Fybroc pump, as standard, is equipped with a single outside seal with stationary seal face and rotating compression unit, or a double inside seal with stationary seal faces and rotating double seal compression unit. The following installation instructions are based on these seal types. When other types of seals are used, please refer to the manufacturer's installation data. Determine the type of seal being used and refer to the following sections.

SINGLE OUTSIDE SEAL INSTALLATION JOHN CRANE TYPE 8B2

- 1) Remove the mechanical seal from its packaging, inspect for any damage, and keep seal faces clean and free from contaminants during installation. **DO NOT GREASE OR LUBRICATE SEAL FACES.**

- 2) Install the inboard stationary gasket and the stationary seal insert into their bores on the pump cover. Then place the outboard stationary gasket over the stationary insert. Next place the seal gland over the stationary insert and gaskets, making sure that all the gaskets have been installed properly before securing the gland bolts. Be sure that the gland pilot is properly engaged, and draw up the gland bolts evenly, cross staggering adjustment of the bolts. Proper gland bolt adjustment is especially important where clamp style inserts are used. The gland bolts should be torqued to a maximum of 10 ft/lbs.
- 3) Lightly coat the impeller sleeve with a suitable lubricant. Carefully slide impeller sleeve through the cover, being careful not to chip the stationary sealing face.
- 4) Lubricate the rotary unit o-ring with a suitable lubricant. Then engage the rotary assembly over the impeller sleeve. Use a slight twisting motion as the rotary unit is slid down the impeller sleeve until it touches the stationary sealing face. Do not tighten set screws or remove setting clips.
- 5) Mount the impeller, cover and seal assembly onto the pump adapter, making sure the impeller threads are firmly bottomed on the shaft threads. Install the cover shims (Item 67) between the pump adapter and cover.
- 6) Install the segment key (Item 14A) in the corresponding slot at the rear of the impeller sleeve. Make sure the teeth are properly engaged and install locking ring (Item 14B).
- 7) Install cover o-ring (Item 73), casing (Item 1) and secure with the casing bolts, nuts and washers (Items 1C, 1D, 1E). Make sure the o-ring is in place and that the impeller is not contacting the casing and tighten the casing bolts.
- 8) Rotate the motor shaft manually while pushing on the motor shaft to take up any shaft end float. Confirm no binding exists. Ensure that the seal faces are still contacting by sliding the seal rotary unit until it touches the stationary unit with a slight twisting motion. Tighten the rotary unit set screws and remove the setting clips.

- 9) Replace fan and/or fan cover on motor and make appropriate piping connections to the seal assembly.

DOUBLE SEAL INSTALLATION JOHN CRANE TYPE 8-1T

- 1) Remove the mechanical seal from its packaging, inspect for any damage, keep seal faces clean and free from contaminants during installation. **DO NOT GREASE OR LUBRICATE SEAL FACES.**
- 2) Lightly lubricate the inboard stationary insert o-ring and cover bore with a suitable lubricant and then install the inboard stationary into the pump cover bore.
- 3) Lightly lubricate the outboard stationary insert o-ring and gland bore and then install the outboard stationary into the gland bore.
- 4) Lightly coat the impeller sleeve with a suitable lubricant. Carefully slide impeller sleeve through the cover, being careful not to chip the stationary sealing face.
- 5) Lubricate the rotary unit o-rings with a suitable lubricant. Then engage the rotary assembly over the impeller sleeve. Use a slight twisting motion as the rotary unit is slid down the impeller sleeve until it touches the stationary sealing face. Do not tighten set screws.
- 6) Install the gland o-ring into its groove on the gland. Then place the gland over the rotating seal assembly, making sure the gland o-ring is in place before securing the gland bolts. Be sure that the gland pilot is properly engaged, and draw up the gland bolts evenly, cross staggering adjustment of the bolts. The gland bolts should be torqued to a maximum of 10 ft/lbs.
- 7) Mount the impeller, cover and seal assembly onto the pump adapter, making sure the impeller threads are firmly bottomed on the shaft threads. Install the cover shims (Item 67) between the pump adapter and cover.
- 8) Install the segment key (Item 14A) in the corresponding slot at the rear of the impeller sleeve. Make sure the teeth are properly engaged and install locking ring (Item 14B).

- 9) Install the cover o-ring (Item 73), casing (Item 1) and secure it with the casing bolts, nuts and washers (Items 1C, 1D, 1E). Make sure the o-ring is in place and that the impeller is not contacting the casing and tighten the casing bolts.
- 10) Rotate the motor shaft manually while pushing on the motor shaft to take up any shaft end float. Confirm no binding exists. Remove the pipe plug in the bottom of the gland and tighten the seal rotary assembly set screws, centering the set screws with the pipe plug hole. Replace pipe plug and make appropriate piping connections to the seal assembly.
- 11) Replace fan and or fan cover on motor, make appropriate piping connections to the seal assembly.

DOUBLE SEAL INSTALLATION JOHN CRANE TYPE 8-D

- 1) Remove the mechanical seal from its packaging, inspect for any damage, keep seal faces clean and free from contaminants during installation.
DO NOT GREASE OR LUBRICATE SEAL FACES.
- 2) Lightly lubricate the inboard stationary insert o-ring and cover bore and install the inboard stationary into the pump cover bore.
- 3) Lightly lubricate the outboard stationary insert o-ring and gland bore and install the outboard stationary into the gland bore.
- 4) Lightly coat the impeller sleeve with a soapy water solution. Carefully slide impeller sleeve through the cover, being careful not to chip the stationary sealing face.
NOTE: The John Crane 8-D is a friction drive type of seal, the impeller sleeve and rotary unit should be lubricated with a soapy water solution to ease installation without reducing the frictional drive of the rotary unit.
- 5) Lubricate the rotary unit o-rings with a soapy water solution. Then engage the rotary assembly over the impeller sleeve. Use a slight twisting motion as the rotary unit is slid down the impeller sleeve until it touches the stationary sealing face.
- 6) Install the gland o-ring into its groove on the gland. Then place the gland over the rotating

seal assembly, making sure the gland o-ring is in place before securing the gland bolts. Be sure that the gland pilot is properly engaged, and draw up the gland bolts evenly, cross staggering adjustment of the bolts. The gland bolts should be torqued to a maximum of 10 ft/lbs.

- 7) Mount the impeller cover, and seal assembly onto the power frame, making sure the impeller threads are firmly bottomed on the shaft threads. Install the cover shims (Item 67) between the pump adapter and cover.
- 8) Install the segment key (Item 14A) in the corresponding slot at the rear of the impeller sleeve. Make sure the teeth are properly engaged and install locking ring (Item 14B).
- 9) Install cover o-ring (Item 73), casing (Item 1) and secure with the casing bolts, nuts and washers (Items 1C, 1D, 1E). Make sure the o-ring is in place and that the impeller is not contacting the casing and tighten the casing bolts.
- 10) Rotate the motor shaft manually while pushing on the motor shaft to take up any shaft end float. Confirm no binding exists.
- 11) Replace fan and or fan cover on motor.
- 12) The 8-D seal is self centering and requires no adjustment. Make appropriate piping connections to the seal assembly.

IMPELLER ADJUSTMENT

The close coupled 1530 series design allows adjustment of the impeller clearance between the pump casing wall and the impeller face. The pump impeller is adjusted at the factory during assembly and should not require further adjustment upon installation.

Impeller adjustment will be required when a drop in head and/or capacity indicates a change in clearances, or when existing components of the pump are replaced. Refer to the following table for recommended clearance when adjusting impeller on horizontal pumps.

Impeller Diameter	Clearance
Up to 8"	.015"
8" to 10"	.020"
10" to 13"	.025"

- 1) When existing components of the pump are replaced with the exception of the casing, refer to the assembly section of this manual for proper impeller adjustment.
- 2) For impeller adjustment to compensate for wear follow the procedure below.
 - A) Lock out the switch or circuit breaker in the "OFF" position so that the motor cannot be accidentally started.
 - B) Loosen set screws or other holding devices if so provided on mechanical seals before adjusting impeller to prevent seal face damage.
 - C) Loosen bolts holding motor to base and loosen casing bolts (Item 1D). Remove fan guard.
 - D) Remove one shim (Item 67) from each side of pump by pulling outward on the extended tabs; this will decrease the impeller front clearance by .010". Slowly retighten casing bolts while turning and pushing forward on the motor shaft to be sure no binding occurs. If binding occurs from the impeller rubbing the casing, the shims that were removed will have to be replaced
 - E) Continue this procedure until the impeller

starts to contact the casing. At this point replace the appropriate number of shims to obtain the approximate impeller clearance shown in the table above.

- F) Reset and tighten the mechanical seal per the seal manufacturers instructions and retighten the motor mounting bolts. Replace fan guard.

WARNING: SOME MOTORS HAVE END FLOAT IN THE SHAFT. THIS MUST BE COMPENSATED FOR OR THE AXIAL LOADS DEVELOPED WHEN THE PUMP IS RUNNING WILL PULL THE IMPELLER INTO THE CASING, CAUSING PUMP DAMAGE.

OPERATIONAL START-UP CHECKLIST

- Foundation level and baseplate grouted.
- Foundation bolts tight.
- Motor and pump mounting bolts tight.
- Suction and discharge connections secure.
- Flush piping installed if required.
- Electrical connections secure and covered.
- Turn motor shaft by hand, ensure that it does not bind.
- Jog motor/Check rotation.
- Ensure seal is properly flushed.
- Suction valve is open, Discharge valve is slightly open.
- Ensure that pump is primed.
- Start pump and open discharge valve to desired flow rate.
- Check flush water flow and pressure.
- Check for excessive vibration.
- Check mechanical seal for no leaks after run-in.

1530 SERIES GROUP 1

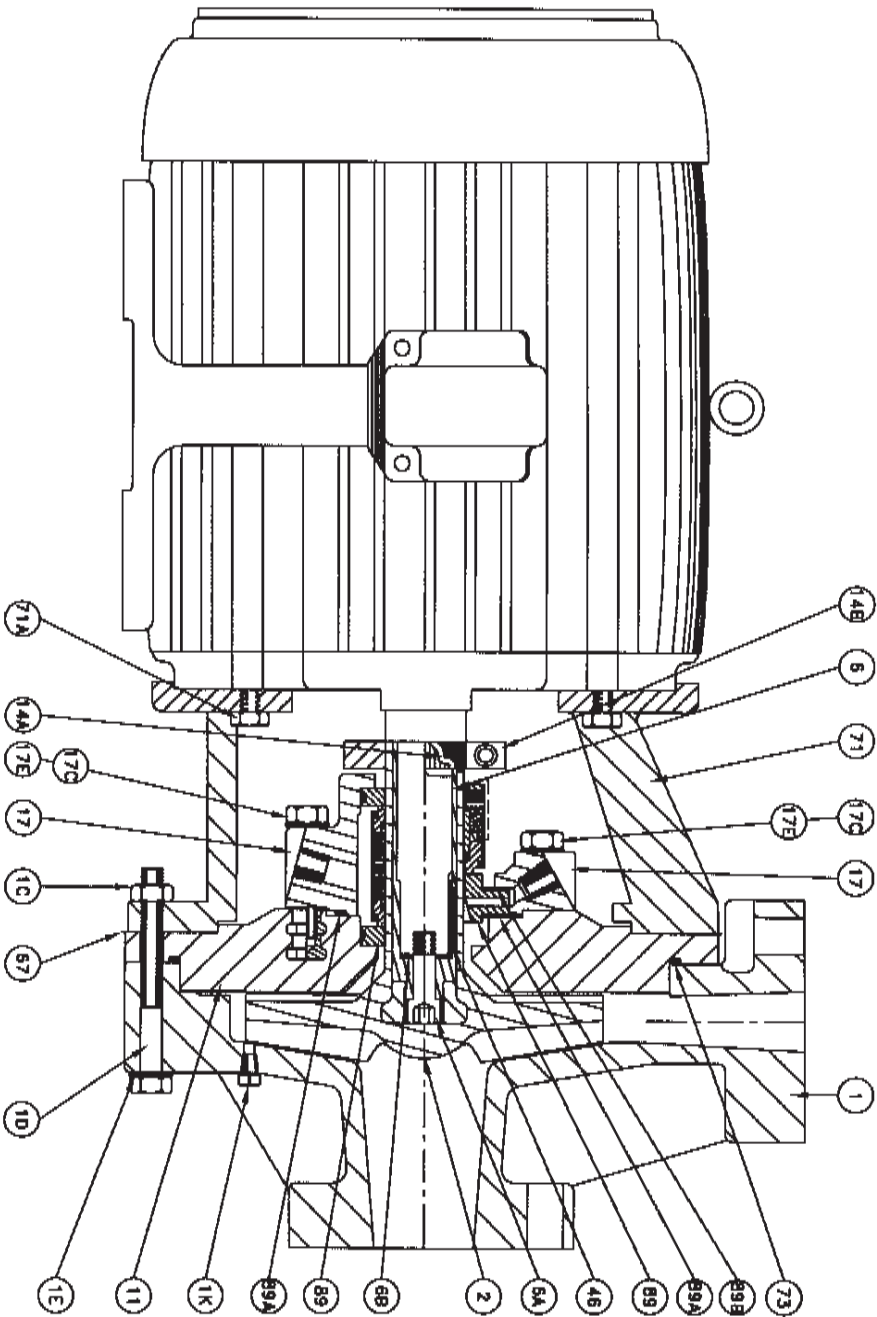

PART #	DESCRIPTION	QTY.
1	CASING	1
1C	CASING NUT	6
10	CASING BOLT	6
1E	CASING WASHER	6
1K	DRAIN PLUG (opt.)	1
2	IMPELLER	1
8	SHAFT	1
5A	SHAFT SCREW	1
5B	SHAFT SHIM	0-4
11	COVER	1
14A	SEGMENT KEY	1
14B	LOCKING RING	1
17	GLAND RING	1
17C	GLAND BOLT	4
17E	GLAND WASHER	4
46	KEY	1
67	SHIM (approx.)	12
71	PUMP ADAPTOR	1
71A	ADAPTOR SCREW	4
73	O-RING COVER	1
89	MECHANICAL SEAL	1
89A	GLAND SEAL COVER	1
89B	GLAND SEAL, REAR	1
-	MOTOR, JM FRAME	1

MODELS
 1X1-1/2X6
 1-1/2X3X6
 2X3X6
 1X1-1/2X8

1530 SERIES GROUP 2

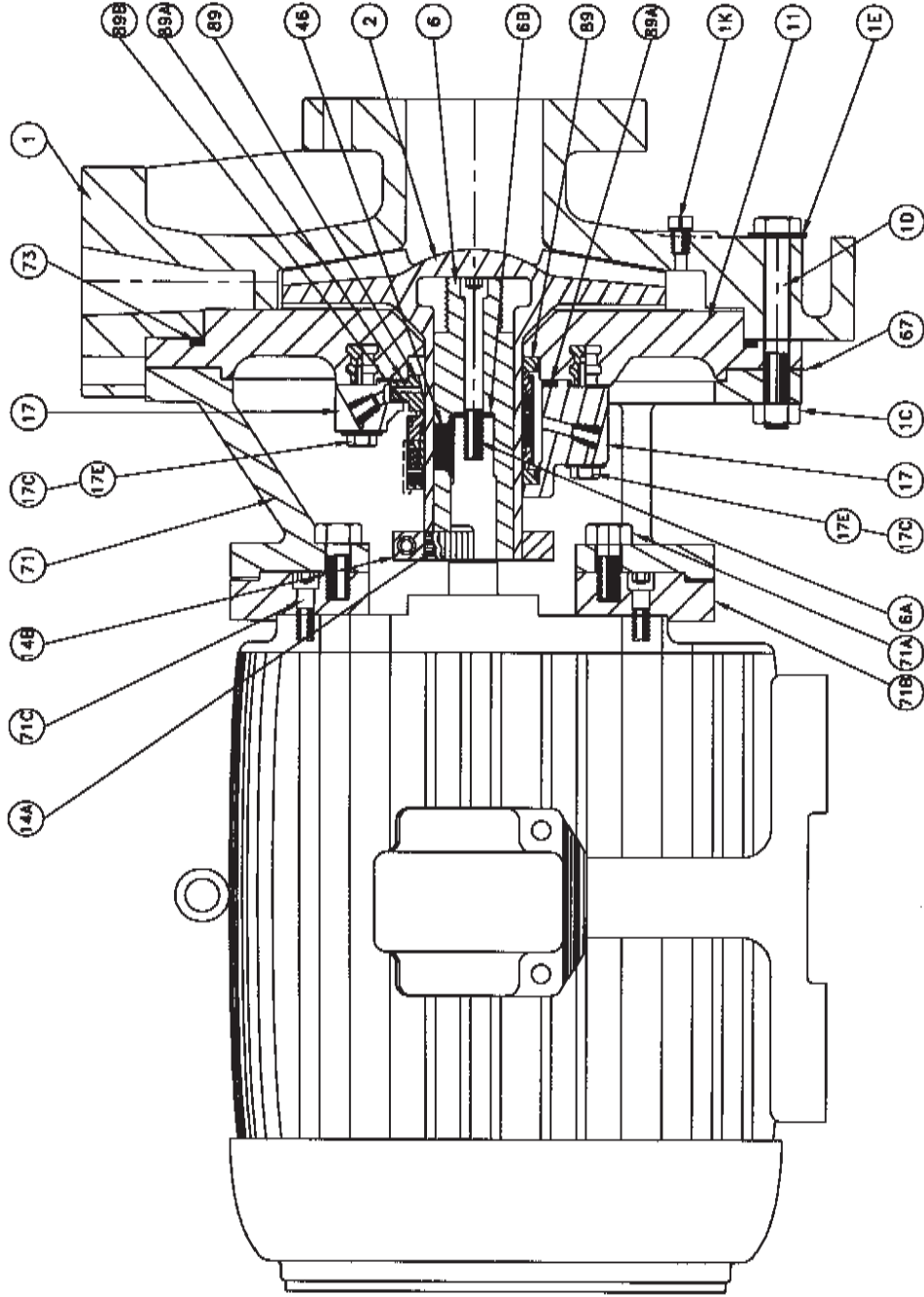

PART #	DESCRIPTION	QTY.
1	CASING	1
1C	CASING NUT	8-16
1D	CASING BOLT	8-16
1E	CASING WASHER	8-16
1K	DRAIN PLUG (opt.)	1
2	IMPELLER	1
6	SHAFT	1
6A	SHAFT SCREW	1
6B	SHAFT SHIM	0-4
11	COVER	1
14A	SEGMENT KEY	1
14B	LOCKING RING	1
17	GLAND RING	1
17C	GLAND BOLT	4
17E	GLAND WASHER	4
46	KEY	1
67	SHIM (approx.)	12
71	PUMP ADAPTOR	1
71A	SCREW, ADAPTOR-PUMP	5
71B	MOTOR ADAPTOR	1
71C	SCREW, ADAPTOR-MOTOR	4
73	O-RING COVER	1
89	MECHANICAL SEAL	1
89A	GLAND SEAL, COVER	1
89B	GLAND SEAL, REAR	1
-	MOTOR, JM FRAME	1

MODELS
 1-1/2X3X8 3X4X10
 2X3X8 4X4X10
 3X4X8 4X6X10
 1X2X10 2X3X13
 1-1/2X3X10 3X4X13
 2X3X10 4X6X13

1530 SERIES SEAL AND STUFFING BOX ARRANGEMENTS

PRODUCT FLUSH: A portion of the pumped fluid is recirculated through the stuffing box to provide lubrication and cooling to the seal. Use plastic fittings only.

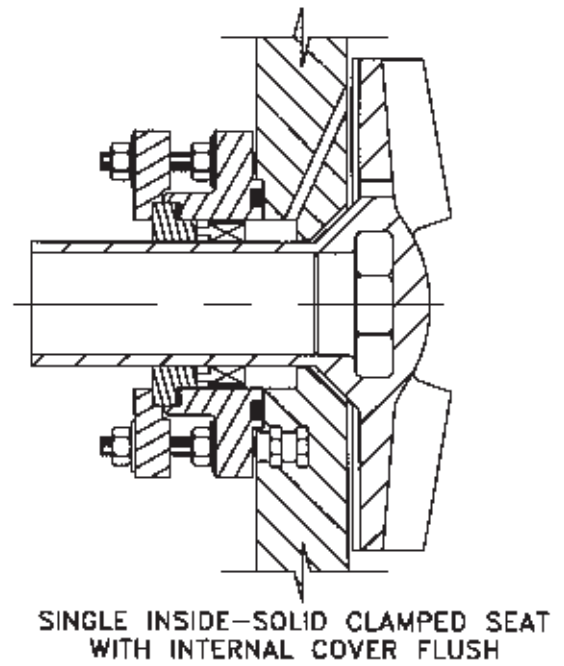
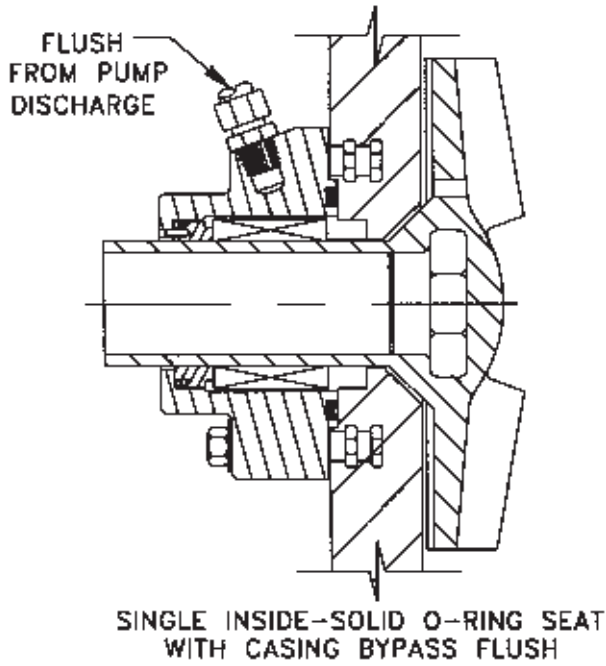
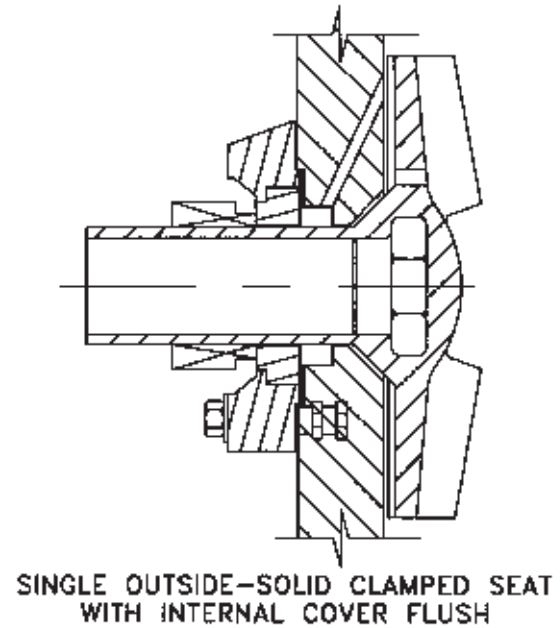
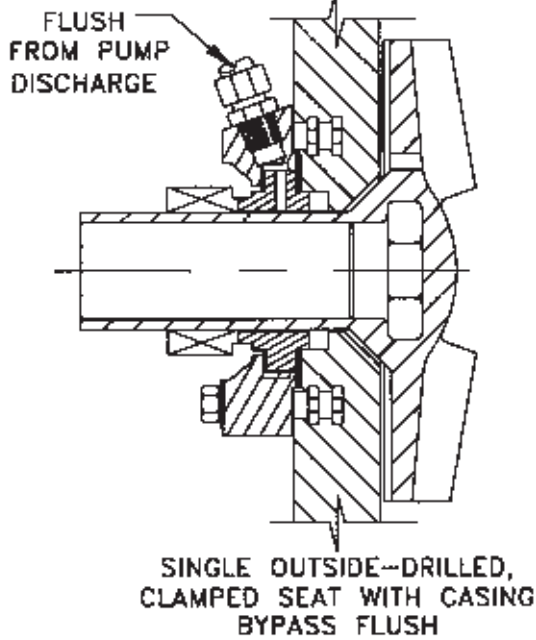

1530 SERIES SEAL AND STUFFING BOX ARRANGEMENTS

EXTERNAL FLUSH: An external source of clean fluid is required at the stuffing box to provide lubrication and cooling. Use plastic fittings only.

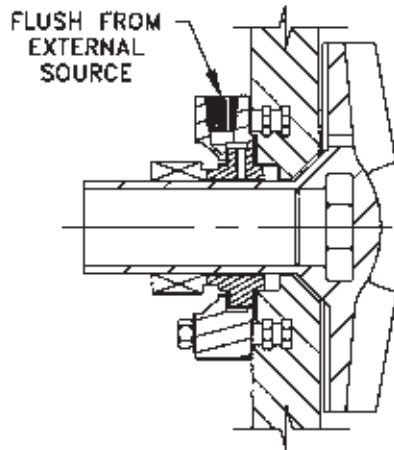

SINGLE OUTSIDE-DRILLED & CLAMPED SEAT W/EXTERNAL FLUSH

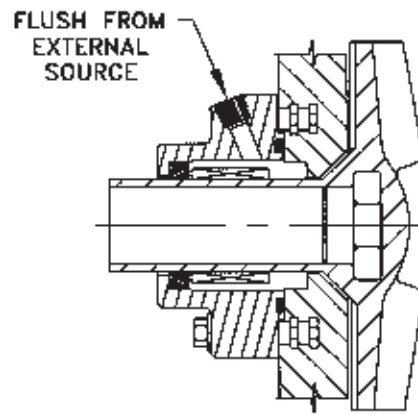

SINGLE INSIDE-SOLID O-RING SEAT W/EXTERNAL FLUSH

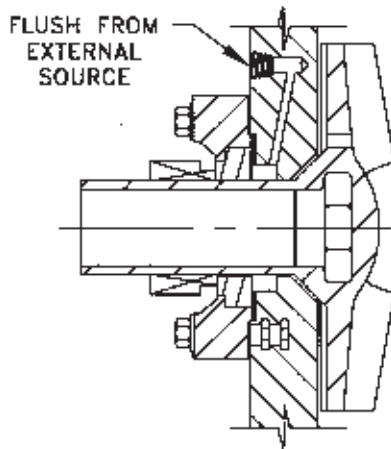

SINGLE OUTSIDE-SOLID CLAMPED SEAT W/EXTERNAL COVER FLUSH

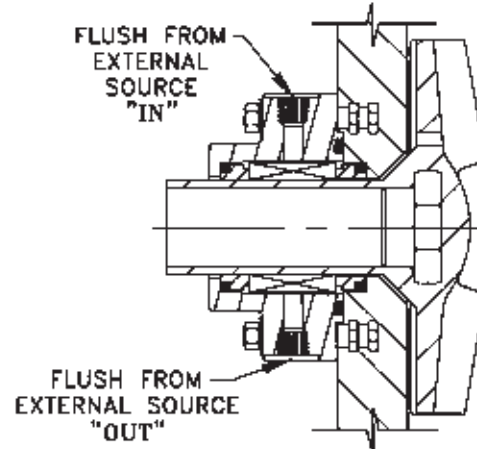

DOUBLE INSIDE W/EXTERNAL FLUSH

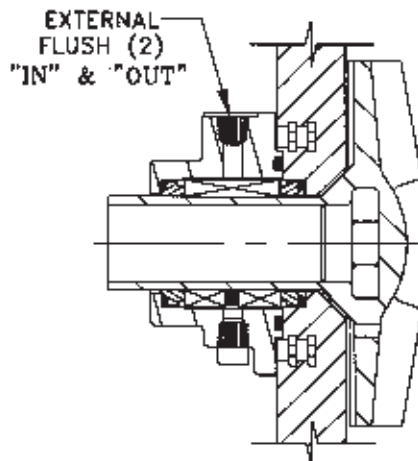

DOUBLE INSIDE-LOCKED ROTARY W/EXTERNAL FLUSH

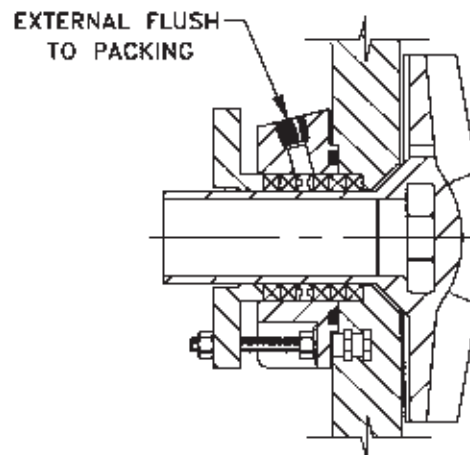

PACKING

FLUSH PIPING FOR SINGLE MECHANICAL SEAL

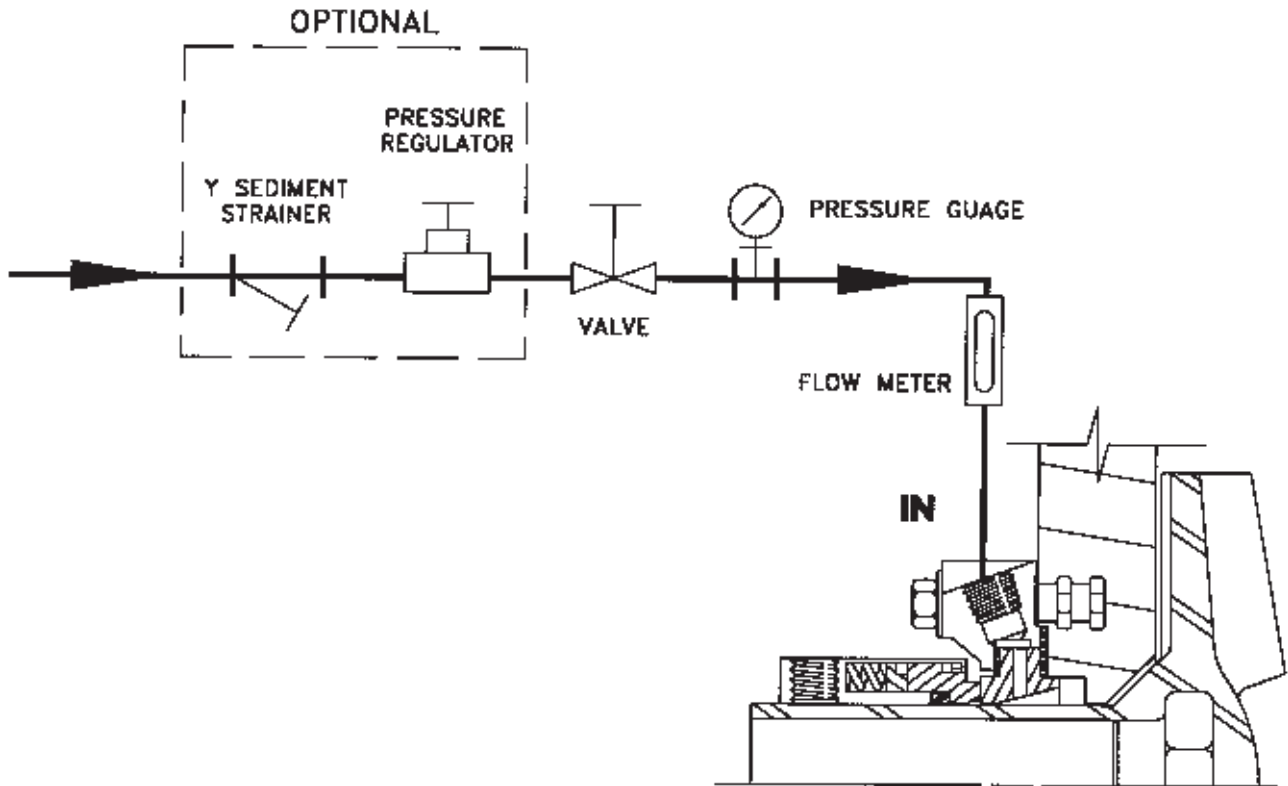

FLUSH FLOW RATE FOR SINGLE SEAL

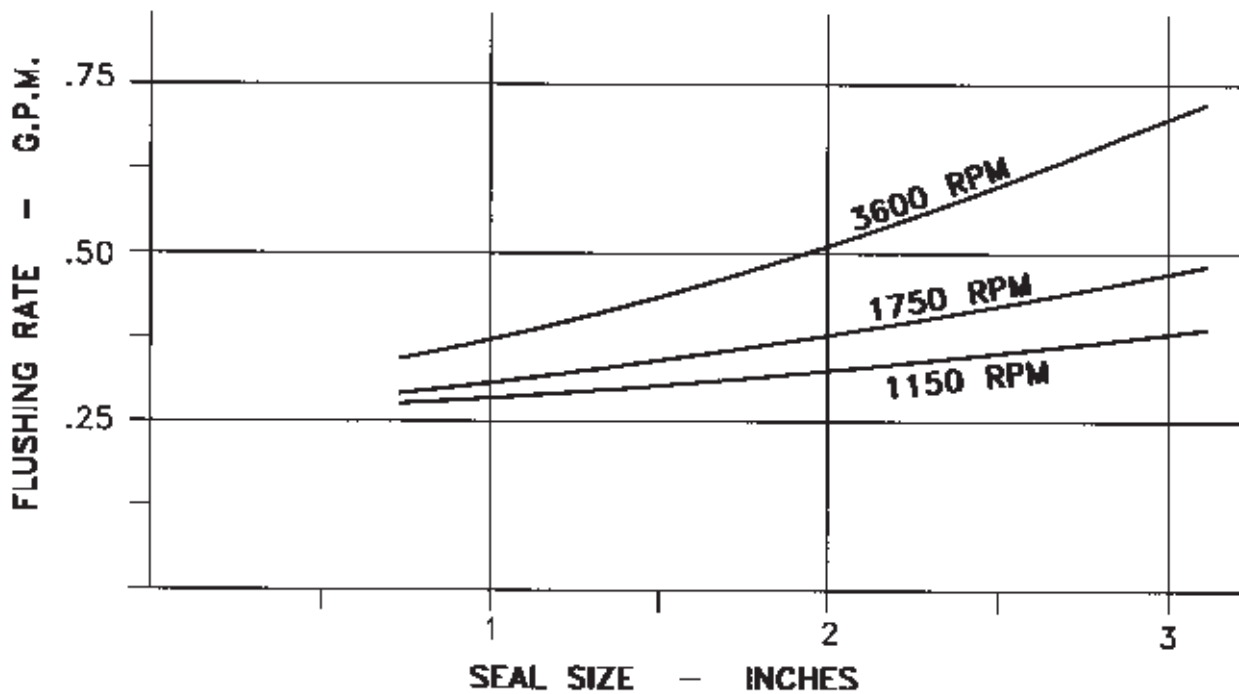

FLUSH PRESSURE - 15 TO 25 PSI ABOVE STUFFING BOX PRESSURE
 FLUSH LIQUID TEMPERATURE - 125°F (50°C) MAXIMUM

FLUSH PIPING FOR DOUBLE INSIDE MECHANICAL SEAL

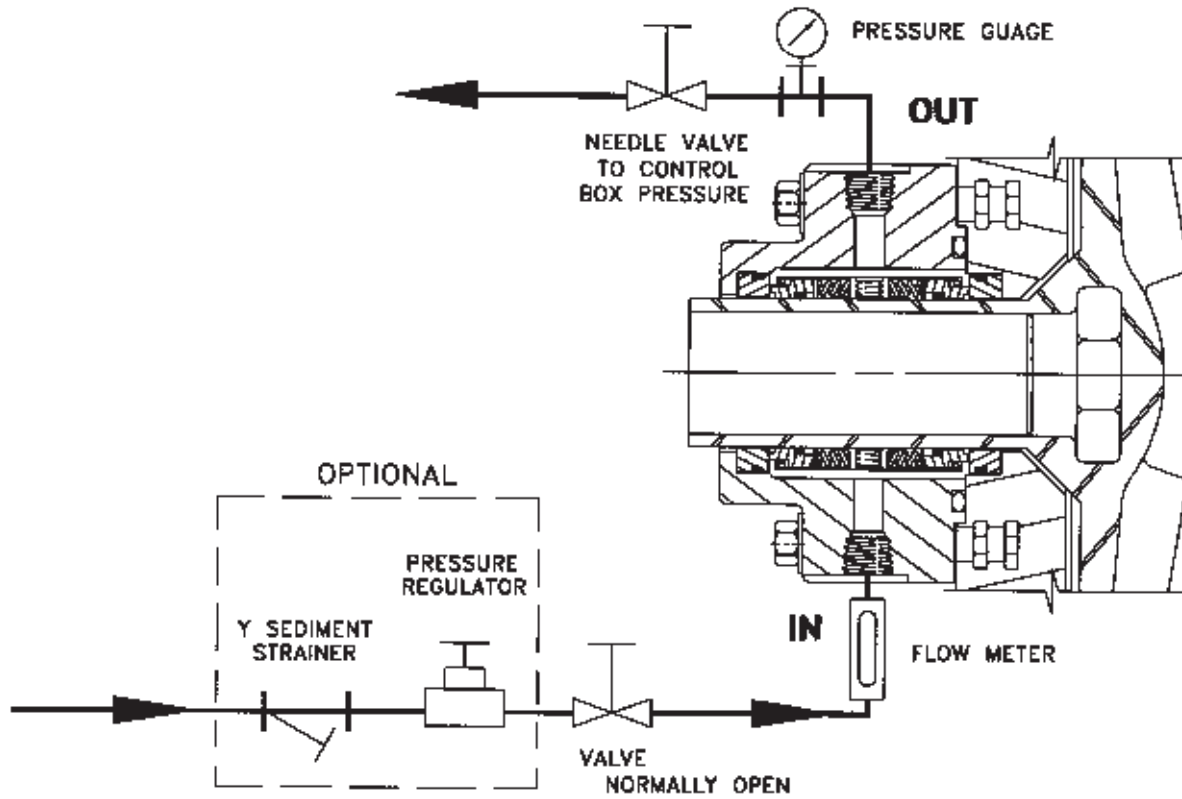

FLUSH FLOW RATE FOR DOUBLE SEAL

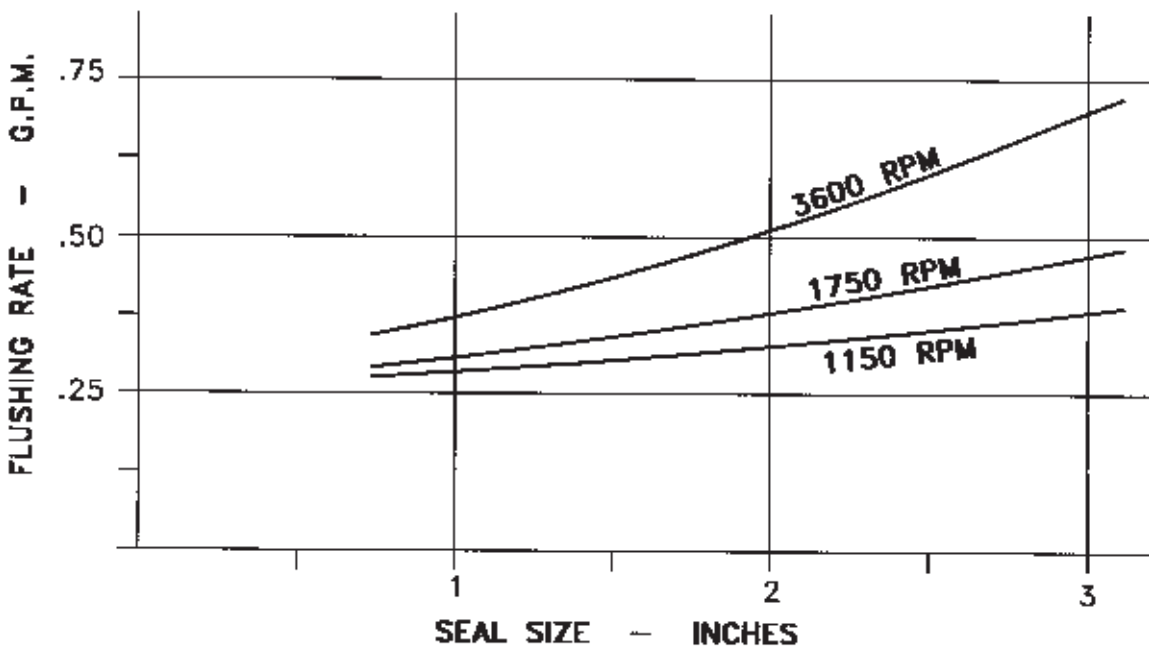

FLUSH PRESSURE - 15 TO 25 PSI ABOVE STUFFING BOX PRESSURE
 FLUSH LIQUID TEMPERATURE - 125°F (50°C) MAXIMUM



Illinois Location:

(847) 841-7867
860 Church Rd
Elgin, IL 60123

Minnesota Location:

(651) 758-7867
330 Mill Bay South Suite 1511
Afton, MN 55001

PumpSupplyInc.com





<p>Illinois Location: (847) 841-7867 860 Church Rd Elgin, IL 60123</p>	
<p>Minnesota Location: (651) 758-7867 330 Mill Bay South Suite 1511 Afton, MN 55001 PumpSupplyInc.com</p>	

©COPYRIGHT 2012 CECO ENVIRONMENTAL FYBROC

FYBROC® IS A REGISTERED TRADEMARK OF CECO ENVIRONMENTAL

07-5327 512



CECO Fybroc

700 Emlen Way • Telford, PA 18969
 P: 215.723.8155 • F: 215.723.2197
 infofhs@onececo.com • www.cecoenviro.com