

SALES AND ENGINEERING DATA

RATIO SERIES:	1:1
FLUID PSIG RANGE:	20 - 120

**PD15X-XXX-XXX, PE15X-XXX-XXX
AND PZ15X-XXX-XXX
1-1/2" METALLIC DIAPHRAGM PUMP**



RELEASED: 8-7-03
REVISED: 6-17-22
(REV: N) S-1281

SPECIFICATIONS

CONSTRUCTION

Model Series	PD15X-XXX-XXX PE15X-XXX-XXX PZ15X-XXX-XXX
Pump Type	Metallic, Air Operated, Double Diaphragm
Ratio	1:1
Material Inlet / Outlet (female)	
PX15X- <u>A</u> XX-XXX	1-1/2 - 11-1/2 NPTF - 1
PX15X- <u>B</u> XX-XXX	Rp 1-1/2 (1-1/2 - 11 BSP)
PX15X- <u>Y</u> XX-XXX	1-1/2" ANSI / DIN Flange
Air Inlet (female)	1/2 - 14 NPT
Air Exhaust (female)	3/4 - 14 NPT
Weight . PX15R- <u>X</u> A-XXX	37.65 lbs (17.08 kgs)
PX15R- <u>X</u> C-XXX	73.2 lbs (33.2 kgs)
PX15R- <u>X</u> H-XXX	86.9 lbs (39.4 kgs)
PX15R- <u>X</u> S-XXX	61.2 lbs (27.8 kgs)
	[add 2.14 lbs (0.97 kg) for aluminum air motor section]
	[add 18.14 lbs (8.23 kg) for stainless steel air motor section]
Air Section Service Kit	637389
Major Air Valve Assembly)	637390-X
Fluid Section Service Kit	637375-XX

PERFORMANCE

Air Inlet Pressure Range	20 - 120 psig (1.4 - 8.3 bar)
Maximum Material Inlet Pressure ...	10 psig (0.69 bar)
Fluid Pressure Range	20 - 120 psig (1.4 - 8.3 bar)
Maximum Flow Rate	
(flooded inlet)	123 gpm (465.6 lpm)
Displacement / Cycle @ 100 psig. ...	0.617 gal. (2.34 lit.)
Maximum Particle Size	1/4" dia. (6.4 mm)
Maximum Temperature Limits (diaphragm / ball / seat material)	
E.P.R./EPDM	-60° to 280° F (-51° to 138° C)
Hytrel®	-20° to 180° F (-29° to 82° C)
Nitrile	10° to 180° F (-12 to 82° C)
Polypropylene	32° to 175° F (0° to 79° C)
Santoprene®	-40° to 225° F (-40° to 107° C)
PTFE	40° to 225° F (4° to 107° C)
Viton®	-40° to 350° F (-40° to 177° C)
Noise Level @ 70 psig - 60 cpm	82.8 dB(A) ^①
① The pump sound pressure level has been updated to an Equivalent Continuous Sound Level (LAeq) to meet the intent of ANSI S1. 13-1971, CAGI-PNEUROP S5.1 using four microphone locations.	
NOTE: Performance tested with 95845 Diaphragm Check Valve.	

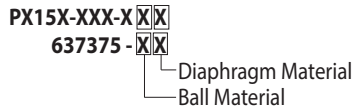

EXAMPLE: Model # PD15S-ASS-SAA
Fluid Section Service Kit is 637375-AA

Illinois Location:
(847) 841-7867
860 Church Rd Elgin, IL 60120

Minnesota Location:
(651) 758-7867
330 Mill Bay South Suite 100
Afton, MN 55001

PumpSupplyInc.com

DIMENSIONAL DATA

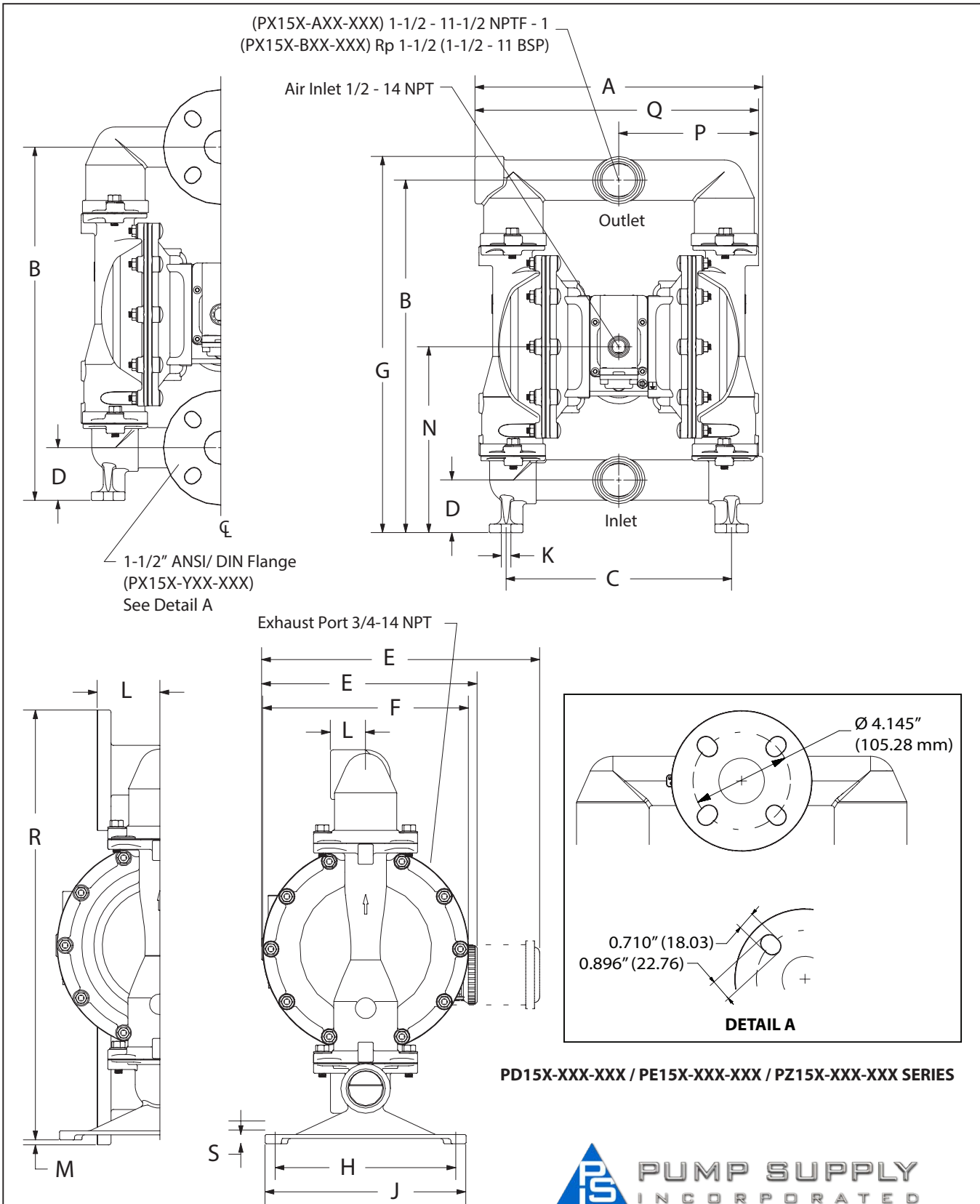

DIMENSIONS

A - see below	E - see below	J - 10" (254.0 mm)	N - 9.68" (246.0 mm)		
B - 18.37" (466.7 mm)	F - 10.25" (260.4 mm)	K - 0.5" (12.7 mm)	P - see below		
C - 11.75" (298.5 mm)	G - 19.62" (498.1 mm)	L - see below	Q - see below		
D - 2.75" (69.9 mm)	H - 9" (228.6 mm)	M - 0.25" (6.4 mm)	R - 21.43" (543.9 mm)		
			S - see below		
"A"	"L"	"P"	"Q"	"S"	"E"
PX15X-XAX-XXX 14.87" (377.8 mm)	1.75" (44.5 mm)	7.21" (183.4 mm)	14.71" (373.9 mm)	0.5" (12.7 mm)	PX15A-XXX-XXX 14.03" (356.2 mm)
PX15X-XCX-XXX 14.62" (371.5 mm)	1.75" (44.5 mm)	7.18" (182.6 mm)	14.5" (368.3 mm)	0.25" (6.4 mm)	PX15R-XXX-XXX 11.09" (281.3 mm)
PX15X-XHX-XXX 14.56" (370.0 mm)	3.12" (79.4 mm)	7.18" (182.6 mm)	14.5" (368.3 mm)	0.25" (6.4 mm)	PX15S-XXX-XXX 13.87" (352.4 mm)
PX15X-ASX-XXX 14.78" (375.5 mm)	1.75" (44.5 mm)	7.28" (185.0 mm)	14.81" (375.5 mm)	0.46" (11.4 mm)	
PX15X-BSX-XXX 14.78" (375.5 mm)	1.75" (44.5 mm)	7.28" (185.0 mm)	14.81" (375.5 mm)	0.46" (11.4 mm)	
PX15X-YSX-XXX 14.56" (370.0 mm)	3.12" (79.4 mm)	7.28" (185.0 mm)	14.56" (370.0 mm)	0.46" (11.4 mm)	



PERFORMANCE CURVES

PX15X-XXX-XXX 1-1/2" METALLIC DIAPHRAGM PUMP

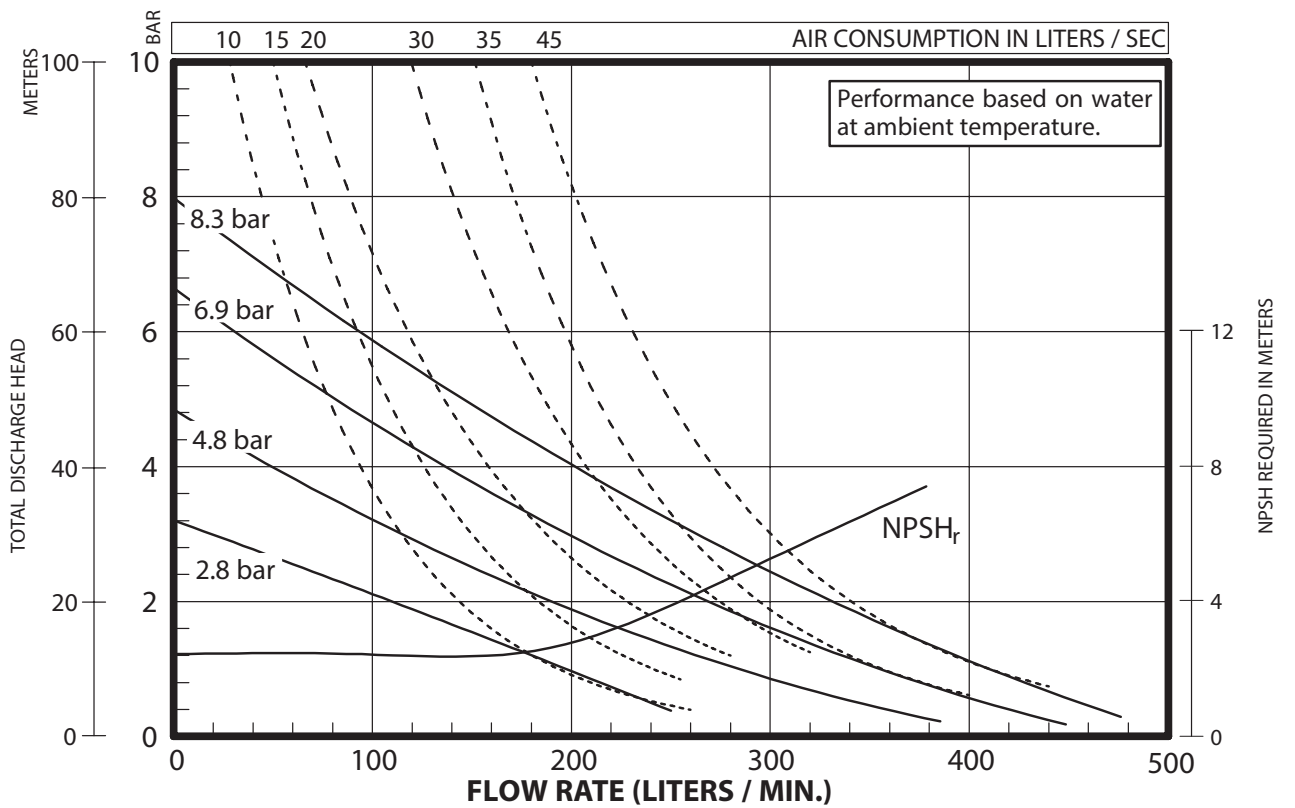
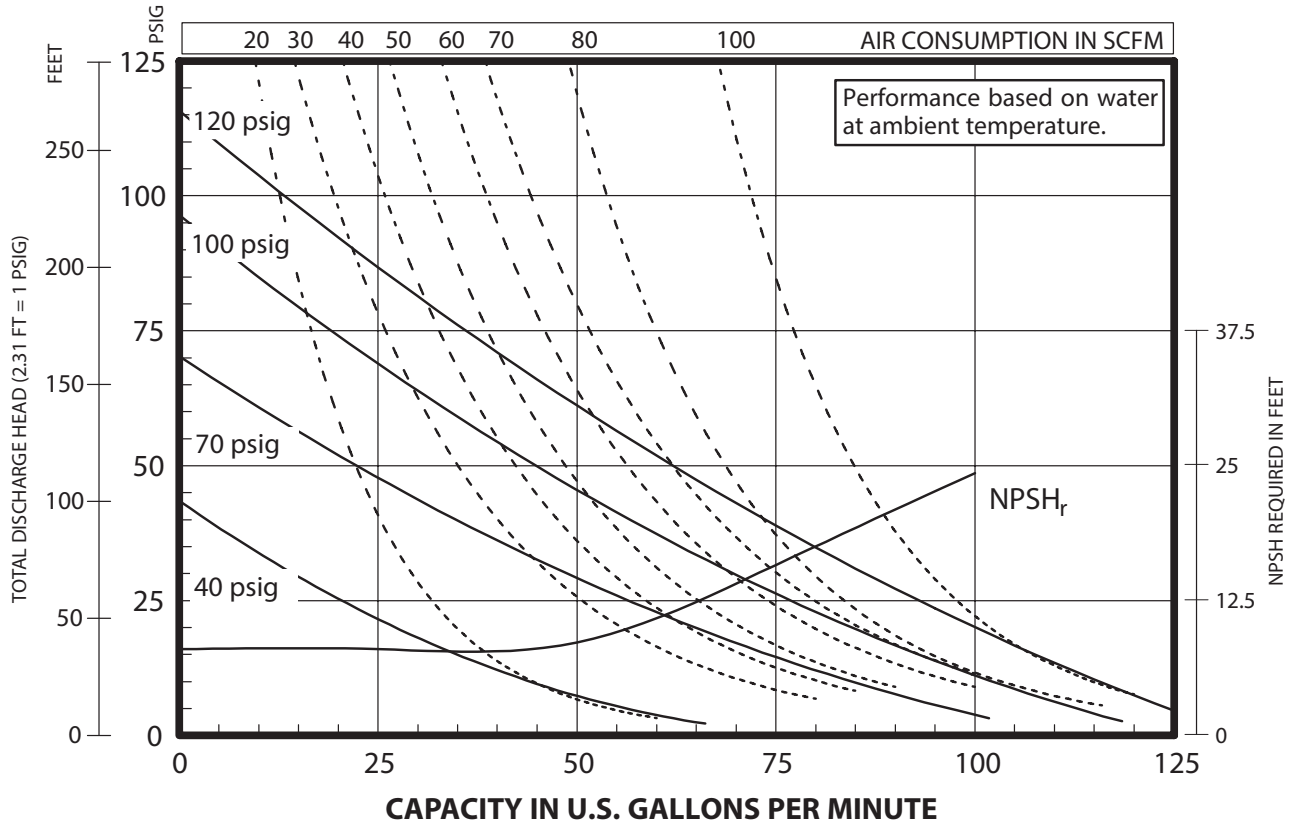

NOTE: Performance tested with 95845 Diaphragm Check Valve.

PD15X-XXX-XXX / PE15X-XXX-XXX / PZ15X-XXX-XXX SERIES



PUMP SUPPLY
INCORPORATED

PERFORMANCE CURVES

PE15X-XXX-XXX-XXEX & PE15X-XXX-XXX-XXFX 1-1/2" METALLIC DIAPHRAGM PUMP

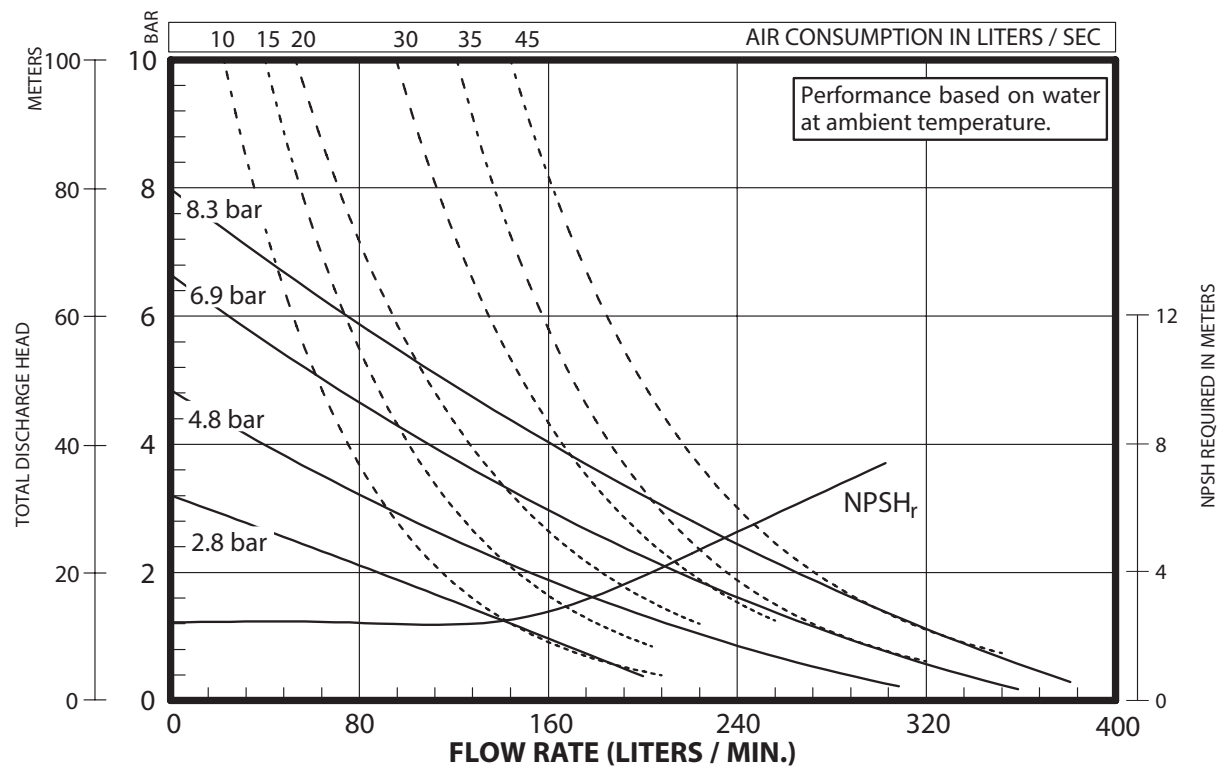
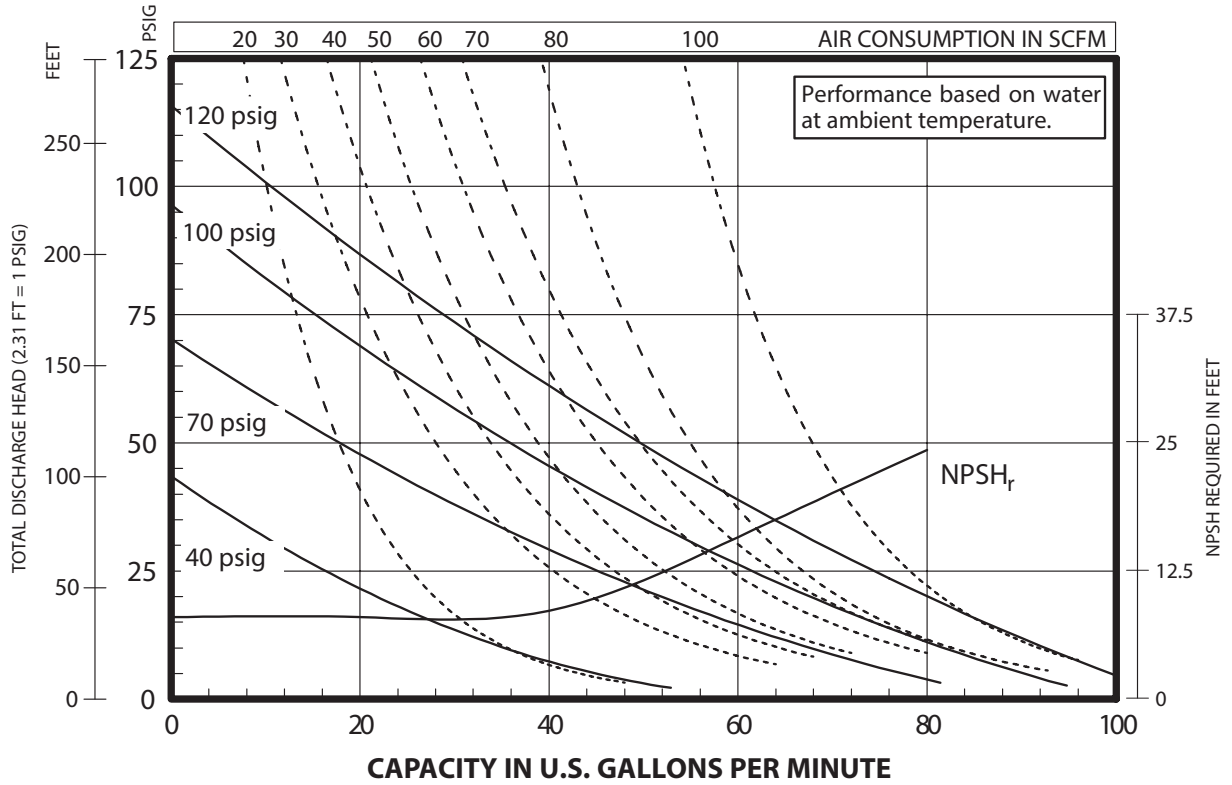

NOTE: Performance tested with 95845 Diaphragm Check Valve.

PD15X-XXX-XXX / PE15X-XXX-XXX / PZ15X-XXX-XXX SERIES



PUMP SUPPLY INCORPORATED