



## **MODELS: G 702 TM, G 706 TM**

**OPERATING INSTRUCTIONS, INSTALLATION & MAINTENANCE  
MANUAL INCLUDING SPARE PARTS LIST**



**Mody Pumps Inc.**

**2166 Zeus Court**

**Bakersfield, CA 93308**

**Tel.: (661) 392-7600 FAX.: (661) 392-7601**

**E-Mail: [sales@modypump.com](mailto:sales@modypump.com)**

**<http://www.modypump.com>**



**ISO 9001 Certified**



## LIFE IS PRECIOUS - THINK SAFETY

1. Most accidents can be avoided by using COMMON SENSE.
2. Please read the operation and maintenance instruction manual supplied with the pump. If you did not receive one, please call your local distributor before pump installation.
3. Do not wear loose apparel that may become entangled in the impeller or other moving parts.
4. Always use appropriate safety equipment, such as safety glasses, when working on the pump or piping.
5. Pumps build up heat and pressure during operation-allow time for pumps to cool before handling or servicing.
6. Only qualified service personnel should install, operate and repair pump.
7. Keep clear of suction and discharge openings. DO NOT insert fingers in pump with power connected.
8. Do not pump flammable or hazardous materials (gasoline, acids, alkalis, etc.)
9. Do not block or restrict discharge hose, as it may whip or burst catastrophically under pressure.
10. Make sure lifting handles/hooks are securely fastened each time before lifting.
11. Do not lift pump by the power cord under any circumstances.
12. Do not exceed manufacturer's recommendation for optimum performance, as this could cause the motor/pump to overheat and lead to premature wear or failure.
13. Secure the pump in its operating position so it does not tip over, fall or slide.
14. Keep away from impeller when power is connected.
15. Submersible Pumps are not approved for use in swimming pools, recreational water installations, decorative fountains or any installation where human contact with the pumped fluid is common.
16. Do not operate pump without adequate protection and safety devices in place.
17. Always replace safety devices that have been removed during service or repair.
18. To reduce risk of electrical shock, pump must be properly grounded in accordance with the National Electric Code and all applicable state and local codes and ordinances.
19. To reduce risk of electrical shock, always disconnect the pump from the power source before handling or servicing.
20. Any wiring of pumps should be performed by a qualified electrician.
21. Never operate a pump with a power cord that has frayed or brittle insulation.
22. Cable should be protected at all times to avoid punctures, cuts, and abrasions - inspect frequently.
23. Never handle connected - "hot" power cords with wet hands.
24. Never operate a pump with a plug-in type power cord without a ground fault circuit interrupter, adequate overload and short circuit protection.

**IMPORTANT !!!** MODY Pumps Inc. is not responsible for losses, injury, or death resulting from a failure to observe these safety precautions, misuse or abuse of pumps or equipment.

# **INTRODUCTION**

THE “*mody*” ELECTRIC DRIVEN PORTABLE SUBMERSIBLE PUMPS HAVE BEEN DEVELOPED DUE TO A LONG FELT NEED OF HAVING A TRULY MAINTENANCE FREE PUMPSET FOR VARIOUS APPLICATIONS. THE PUMP IS A LIGHTWEIGHT, COMPACT UNIT ENABLING IT TO BE USED IN MOST SEA-CRAFT AND DIFFICULT LAND INSTALLATIONS. THE UNIT CONSISTS OF A VERTICAL CENTRIFUGAL PUMP WITH AN IN-BUILT SQUIRREL CAGE, INDUCTION ELECTRIC MOTOR WHICH IS AVAILABLE FOR VARIOUS ELECTRIC SUPPLY CONFIGURATIONS. THE PUMPED WATER IS USED AS A COOLING MEDIUM WHICH COOLS THE ELECTRIC MOTOR. THE PUMPSET CAN ALSO BE USED IN ANY POSITION THUS MAKING IT IDEAL FOR DEWATERING IN DIFFICULT LOCATIONS.

**THE SERVICE LIFE OF A SUBMERSIBLE PUMP DEPENDS MAINLY ON TWO THINGS: THE DEPENDABILITY OF THE SEALING SYSTEM AND THE WEAR RESISTANCE OF THE PUMP WEAR PARTS.**

ALL “*mody*” SUBMERSIBLE SUMP PUMPS INCORPORATE A UNIQUE SEALING SYSTEM. THE CONSTRUCTION CONSISTS OF TWO MECHANICAL SEALS, ARRANGED IN TANDEM, IMMERSSED IN AN OIL BATH. THE COMPLETE PACKAGE IS A PRESSURE COMPENSATED SEALING DEVICE WHICH ENSURES A MINIMAL PRESSURE DIFFERENTIAL ACROSS THE SEAL FACES, IRRESPECTIVE OF THE DEPTH SETTING OF THE PUMP OR THE HEAD AGAINST WHICH THE PUMP IS OPERATING.

IN “*mody*” SUBMERSIBLE SUMP PUMPS, ALL WEAR PARTS ARE RUBBER LINED/COVERED AND ARE READILY REPLACEABLE AS NEEDED. BOTH WEAR AND ELECTRICITY CONSUMPTION ARE STILL FURTHER REDUCED WHEN THE PUMPS ARE FITTED WITH LEVEL CONTROLS FOR AUTOMATIC STARTING AND STOPPING.

**IT IS RECOMMENDED THAT IRRESPECTIVE OF TYPE OF PUMP, ADEQUATE MOTOR PROTECTION SWITCHGEAR SHOULD BE USED AT THE INSTALLATION. WE STRONGLY RECOMMEND THE USE OF SUITABLE CONTROL BOXES WHICH ARE AVAILABLE FROM US INCORPORATING ALL REQUIRED PROTECTION.**

IT IS IN THE INTEREST OF THE USER THAT HE GO THROUGH THIS MANUAL IN DETAIL PRIOR TO USING THE PUMP. THE MANUAL WILL HELP HIM UNDERSTAND THE CONSTRUCTIONAL FEATURES AND TO OBTAIN TROUBLE FREE SERVICE FROM THE PUMP.

PLEASE NOTE THAT ALL PART NOS. REFERRED TO IN DISMANTLING AND RE-ASSEMBLY ARE PERTAINING TO MODEL G702T. NUMBERS FOR MODEL G706T ARE INDICATED IN THE DRAWINGS. THE CONSTRUCTION IS IDENTICAL.

## **PURPOSE:**

THE PUMP HAS BASICALLY BEEN DESIGNED AS A DEWATERING UNIT TO PUMP OUT FLOODED INSTALLATIONS OR ANY CONDITIONS THAT NEED DEWATERING OF UNWANTED FLUIDS. THE PUMP HAS BEEN DESIGNED TO HANDLE WATER CONTAMINATED WITH OIL AS WELL AS ABRASIVE PARTICLES NORMALLY ASSOCIATED WITH RAW WATER. THE MAXIMUM SIZE OF PARTICLES THAT CAN BE HANDLED IS APPROX. 0.4”

## **OVERALL DIMENSIONS AND WEIGHT.**

OVERALL HEIGHT                            33.00"/825mm (APPROX.)  
MAX. DIAMETER                            14.20"/360mm (APPROX.)  
MAX. WEIGHT (EXCL. CABLE) 265 lbs.

## **MAINTENANCE SERVICES REQUIRED.**

THE FOLLOWING CHECKS TO BE DONE AT INTERVALS INDICATED BELOW:

1. CONDITION OF SEALS TO BE CHECKED AT EVERY 2500 HOURS OF OPERATION BY ASCERTAINING THE CONDITION OF OIL IN THE SEAL CHAMBER.
2. MONTHLY RUNNING OF PUMP FOR AT LEAST 5/10 MINUTES AND CHECKING OF AMPERES DRAWN AND INSULATION RESISTANCE. (MIN. INSULATION RES. 1 MEG. OHM. AND MAX. CURRENT DRAWN AS PER NAME PLATE)

## **SAFETY PRECAUTIONS.**

1. ENSURE THAT THE INSULATION RESISTANCE OF THE MOTOR IS AT LEAST 1 MEG. OHM BEFORE ENERGIZING THE UNIT.
2. CHECK THAT THE AVAILABLE POWER SUPPLY (VOLTAGE, PHASE, FREQUENCY) MATCHES WITH THE DETAILS ON THE PUMP NAMEPLATE.
3. ENSURE THAT THE GROUND WIRE IN THE CABLE SUPPLIED WITH THE PUMP IS SECURELY EARTHED.
4. ENSURE DISCHARGE CONNECTION IS CORRECTLY AND SECURELY FITTED
5. ENSURE DELIVERY HOSE IS FREE FROM KINKS AND SHARP BENDS.
6. **DO NOT LIFT OR PULL THE PUMP UNDER ANY CIRCUMSTANCES BY MEANS OF THE CABLE.** THE PUMP MUST BE LOWERED/LIFTED FROM THE AREA TO BE PUMPED BY USING A LIFTING ROPE ATTACHED TO THE EYEBOLTS PROVIDED ON THE TOP OF THE PUMP.
7. WHEN THE PUMP IS ENERGIZED IT WILL KICK WHICH IS OPPOSITE TO THE DIRECTION OF ROTATION OF THE IMPELLER. ENSURE THE KICK IS IN THE CORRECT DIRECTION (SEE THE ARROW MARKED ON THE PUMP). SHIFT ANY TWO PHASES IN POWER SUPPLY IF THE KICK IS WRONG.
8. DRY RUNNING OF THE PUMP IS NOT DESIRABLE. HOWEVER THE PUMP WILL NOT BE DAMAGED OR SUFFER ANY ILL EFFECTS IF IT IS RUN DRY FOR SHORT PERIODS (UPTO APPROX. 10 MINUTES).
9. **THE MAXIMUM PUMP SUBMERGENCE RECOMMENDED IS 50 FEET.**
10. ENSURE CORRECT RATING H.R.C. BACK UP PROTECTION FUSES ARE INSTALLED IN POWER CIRCUIT BEFORE STARTING THE PUMP. (REFER TABLE BELOW).
11. **THE MAXIMUM SPECIFIC GRAVITY OF PUMPED FLUID SHOULD NOT EXCEED 1.1.** PUMP IS DESIGNED TO OPERATE IN FLUIDS WITH pH from 5 - 8.
12. IF PUMP IS NOT USED AND LYING IN STORAGE FOR MORE THAN 30 DAYS PLEASE ENSURE THAT THE SEAL FACES ARE NOT GAUGE LOCKED - ROTATE THE IMPELLER/KICK START THE UNIT ONCE A MONTH. REFER TO INSTRUCTIONS ON DISASSEMBLY/REASSEMBLY OF MECH. SEALS IN THE EVENT THE FACES HAVE LOCKED.
13. FULL LOAD AMPS AT 460V IS 22AMPS & AT 400V IS 25AMPS

**MAINS VOLTAGE AT SITE**

220 VOLTS / 3 PHASE  
 380 VOLTS / 3 PHASE  
 460 VOLTS / 3 PHASE  
 575 VOLTS / 3 PHASE

**HRC FUSE RECOMMENDED**

63 AMPERES  
 35 AMPERES  
 31 AMPERES  
 25 AMPERES

**FAULT FINDING IN THE UNIT.**

| <b><u>TROUBLE GUIDE</u></b>                | <b><u>CAUSE</u></b>  | <b><u>REMEDY</u></b>  |
|--|--|---|
| <b><u>PUMP DOES NOT START.</u></b>         | 1.FUSES BLOWN.<br>2.CABLE DAMAGED<br>3.NO POWER.<br>4.BLOCKED IMPELLER.<br>5.STATOR WINDING BURNT.   | 1.REPLACE FUSES<br>2.SHORTEN/REPLACE CABLE<br>3.CHECK POWER SUPPLY.<br>4.CLEAN BOTTOM PARTS.<br>6.REPLACE STATOR/REWIND   |
| <b><u>PUMP STARTS BUT STOPS.</u></b>       | 1.BLOCKED IMPELLER.<br>2.IMPELLER ROT.WRONG<br>3.CONNECTED FOR WRONG VOLTAGE.<br>4.VOLTAGE LOW/HIGH<br>5.CLOGGED STRAINER<br>6.PUMP RUNNING DRY<br>7.WATER TOO WARM (ABOVE 60 DEGREES C) | 1.CLEAN BOTTOM PARTS.<br>2.SHIFT TWO PHASE CONN.<br>3.CHECK & RECONNECT.<br>4.CONTACT POWER CO.<br>5.CLEAN STRAINER<br>6.SWITCH OFF POWER<br>7.SWITCH OFF POWER |
| <b><u>PUMP GIVES TOO LITTLE OUTPUT</u></b> | 1.IMPELLER ROT.BACKWARD.<br>2.PUMP WORN DOWN.<br>3.LONG HOSE AND DIAMETER TOO SMALL.<br>4.PRESSURE HEAD TOO HIGH<br>5.DISCHARGE HOSE TORN<br>6.LEAKING/CRACKED OUTLET                    | 1.SHIFT TWO PHASE CONN.<br>2.REPLACE WEAR PARTS<br>3.CHECK PRESSURE LOSSES<br>4.USE PUMPS IN TANDEM.<br>5.USE NEW HOSE<br>6.REPL.OUTLET/GASKET.                 |

OPTIONAL FEATURES INCLUDE STAR/DELTA START, SEAL PROBE SENSOR OR THERMAL OVERLOAD PROTECTION. EXTERNAL CONTROL BOXES ARE AVAILABLE FOR THE ABOVE FEATURES. PLEASE CONTACT MODY.

## **TECHNICAL DESCRIPTION.**

THE MODY SUBMERSIBLE PUMP IS IN ITSELF A COMPLETE PUMPING STATION. BESIDES A POWER SUPPLY, CONTROL BOX AND A DISCHARGE HOSE NO EXTRA EQUIPMENT IS REQUIRED. THE COMPLETE PUMPSET IS IN A MODULAR CONSTRUCTION ENSURING GOOD AND SIMPLE SERVICEABILITY. MAJOR DESIGN FEATURES ARE AS UNDER:

### **THE MOTOR**

A RUGGED ALUMINUM DIE CAST ROTOR DYNAMICALLY BALANCED TO GRADE 2.5 ACCURACY OF ISO 942. A STAINLESS STEEL SHAFT RUNNING IN TWO BALL BEARINGS. INSULATION CLASS "H" (180 DEGREES CELSIUS). END WINDINGS DULY EPOXY COATED TO PREVENT DETERIORATION OF INSULATION EVEN IN EXTREMELY HUMID CONDITIONS. WINDING WIRE IS DUAL COATED SUITABLE FOR "H" CLASS INSULATION.

### **THE SEAL CHAMBER**

THE HEART OF THE MODY PUMP. TANDEM MECHANICAL, TUNGSTEN CARBIDE V/S TUNGSTEN CARBIDE SEAL FACES (LOWER SEAL) AND TUNGSTEN CARBIDE V/S TUNGSTEN CARBIDE (UPPER SEAL), SECONDARY SEALS OF HNBR RUBBER AND METAL PARTS IN STAINLESS STEEL, RUNNING IN AN OIL BATH, ENCLOSED IN A PRESSURE COMPENSATING RUBBER OIL BAG - CREATES THE ULTIMATE SEAL SOLUTION. THE DESIGN OPTIMIZES SEAL LIFE AND ALLOWS FOR SIX MONTHLY (2500 HOURS) SERVICE INTERVALS.

### **BEARINGS.**

TWO ANGULAR CONTACT BALL BEARINGS (IMPELLER SIDE), ARRANGED BACK TO BACK, FILLED WITH A SPECIAL HIGH TEMPERATURE BEARING GREASE REQUIRING NO PERIODIC MAINTENANCE WHATSOEVER. THE TOP BEARING IS A SINGLE ROW DEEP GROOVE BALL BEARING, GREASE FILLED AND SEALED FOR LIFE.

### **THE HYDRAULIC ELEMENTS.**

THE HARDENED STAINLESS STEEL IMPELLER RUNNING AGAINST A RUBBER LINED DIFFUSER AND WEAR PLATE, CONSTITUTE THE HYDRAULIC ELEMENTS OF THE PUMP. THE IMPELLER/DIFFUSER CAN BE ADJUSTED TO MAINTAIN MAXIMUM OUTPUT AFTER USAGE WITHOUT PARTS REPLACEMENT. IT IS IMPORTANT, HOWEVER, TO MAINTAIN CLEARANCES BETWEEN THE WEAR PARTS.

### **CABLE GLAND ASSEMBLY. (REFER DRG.)**

THE PUMP IS SUPPLIED WITH 50 FEET CABLE AS STANDARD. THE CABLE IS A 4 CORE or 6 CORE (TWO WIRES WILL BE THE OPTIONAL THERMALS) EPR SHEATHED AND INSULATED CABLE CONFORMING TO INT'L STD. THE CABLE IS WATERPROOF AND CAN BE COMPLETELY SUBMERGED IN WATER. THE CABLE IS TERMINATED IN THE PUMP AT THE CABLE GLAND. THE GLAND ASSEMBLY SEALS THE CABLE ON THE OUTSIDE SHEATH AS WELL AS A WATER DAM ARRANGEMENT IS PROVIDED WHICH SEALS THE INDIVIDUAL CORES OF THE CABLE. THIS FEATURE IS UNIQUE AND IS ESSENTIAL TO PREVENT WATER SEEPING THROUGH THE CORES OF THE CABLE INTO THE MOTOR CHAMBER IN THE EVENT OF A CUT CABLE. THE CABLE IS ALSO SHEATHED FOR THE FIRST ONE METER BY MEANS OF A CABLE GRIP MADE OF STAINLESS STEEL. THIS IS ESSENTIAL TO ENSURE THAT THERE IS NO UNDUE STRAIN ON THE CABLE IF THE PUMP IS PULLED OR LOWERED INADVERTENTLY BY MEANS OF THE CABLE. COMPLETE DETAILS OF THE CABLE GLAND ASSEMBLY ARE SHOWN IN THE DRAWING.

## **GALVANIC CORROSION PROTECTION (FOR SEA-WATER DUTY PUMPS ONLY)**

THE PARTS OF THE "MODY" SUBMERSIBLE PUMP THAT ARE IN CONTACT WITH SEA- WATER ARE PRIMARILY OF STAINLESS STEEL AND ALUMINUM. AS SEA-WATER IS AN ELECTROLYTE THE PROBLEM OF GALVANIC CORROSION EXISTS DUE TO THE DIFFERENT ELECTRIC POTENTIALS OF THE MATERIALS IN FLOWING SEA-WATER. TO PREVENT THIS, THE PUMPS ARE EQUIPPED WITH ZINC ANODES FIXED ON THE OUTER CASING AND DIFFUSER. ZINC, BEING THE LESS "NOBLE" METAL (MORE NEGATIVE POTENTIAL) GETS CORRODED THUS PREVENTING CORROSION OF ALUMINUM AND STEEL. IT IS HOWEVER NECESSARY TO INSPECT THE CONDITION OF THE REPLACEABLE ANODES PERIODICALLY AND REPLACE WHENEVER NECESSARY. (TYPICALLY INSPECTION ONCE A YEAR SHOULD SUFFICE)

## **NON REPAIRABLE ITEMS**

1. ALL "O" RINGS TO BE REPLACED WHENEVER PARTS ARE DISMANTLED.
2. SEAL ELASTOMER PARTS SHOULD NEVER BE RE-USED AFTER DIS-ASSEMBLY.
3. DO NOT REFILL BEARING GREASE. NEW BEARINGS MUST BE INSTALLED WITH SPECIAL HIGH TEMPERATURE GREASE.

## **ELECTRICAL INFORMATION.**

MOTORS ARE DESIGNED TO OPERATE ON SINGLE VOLTAGE AND FREQUENCY. MAXIMUM DEVIATION IN VOLTAGE ALLOWED IS +/-6% AND FREQUENCY +/-3%. CHECK NAME PLATE FOR OPERATING VOLTAGE AND FREQUENCY.

## **DISMANTLING AND OVERHAULING.**

### **GENERAL OVERHAUL AND OIL CHECK. (REF. DRGS. NO.DW/042/00 (SHEETS 1 & 2) AND DW/043/00 (SHEETS 1 & 2)**

1. ALWAYS REPLACE O-RINGS WITH NEW ONES WHENEVER DISMANTLING AND RE-ASSEMBLING A PUMP. NEVER RE-USE OLD O-RINGS.
2. ALWAYS ISOLATE THE UNIT BEFORE REMOVING THE CABLE GLAND. BE CAREFUL WITH O-RINGS AND SEALING SURFACES. PROTECT THE CHAMBER AGAINST RAIN AND MOISTURE.
3. DISCONNECT STATOR LEADS. SNIP OFF LEAD WIRE CONNECTORS AND UNSCREW EARTHING SCREW. LOOSEN SCREWS, REMOVE CABLE GROMMET AND CABLE LEAD GROMMET. CLEAN THE SEALING SURFACES CAREFULLY AND GREASE THE NEW O-RINGS BEFORE FITTING THE SAME. DO NOT USE THE OLD O-RINGS.
4. LOOSEN HEX BOLTS AND LOCK WASHERS AND REMOVE BASE PLATE, STRAINER, DIFFUSER CENTER, AND DIFFUSER HOLDER. PRY OUT DIFFUSER RING FROM OUTER CASING. THE DRAWING SHOWS THESE DETAILS. CHECK BY HAND THAT THE ROTOR SHAFT IS NOT JAMMED.
5. PLACE THE PUMP ON THE BOTTOM STUDS. TAP THE OUTER CASING WITH NYLON HAMMERS/MALLET TILL IT LOOSENS FROM THE TOP BRACKET. SEPARATE THE OUTER CASING FROM THE TOP BRACKET BY EMPLOYING TWO SCREW DRIVERS AS LEVERS AND PUSH THE OUTER CASING DOWNWARDS TILL IT STANDS ON THE FLOOR. LIFT THE UNIT BY THE EYEBOLTS CLEAR OFF THE OUTER CASING.

6. THE SEAL CHAMBER CONTAINS APPROX. 5 LITERS OF OIL. THE LEVEL AND CONDITION OF THE OIL SHOULD BE CHECKED EVERY SIX MONTHS. UNSCREW THE OIL PLUGS AND POUR OUT SOME OIL. NOTE THAT THE OIL GETS A SLIGHTLY DARKER SHADE, BUT THIS IS NORMAL AND IS NO CAUSE FOR WORRY. IF THE OIL IS EMULSIFIED BY WATER, THE SEALS HAVE WORN OUT AND MUST BE REMOVED FROM THE ROTOR FOR FURTHER ACTION.

7. LAY DOWN THE PUMP AND REMOVE THE REMAINING PARTS. UNSCREW NUT AND REMOVE LOCK WASHER. USE A PRY BAR TO HOLD IMPELLER WHILE UNSCREWING IMPELLER LOCKNUT AND SLIDE OFF IMPELLER FROM SHAFT. THEN REMOVE TRIMMING SPACERS AND SAND GUARD FROM THE SEAL HOUSING.

8. UNSCREW NUTS AND FOUR STUDS AND REMOVE WEAR PLATE. THIS CAN BE EASILY DONE BY INSERTING TWO SCREWDRIVERS BETWEEN WEAR PLATE AND LOWER BEARING BRACKET AND PRYING THE WEAR PLATE LOOSE. ALL THE PUMP PARTS HAVE BEEN DISMANTLED. REPLACE WORN PARTS.

9. THE OIL DIAPHRAGM IS NOW IN VIEW. UNSCREW BOTH THE OIL PLUGS AND DRAIN OUT THE OIL FROM THE OIL CHAMBER. UNSCREW SOCKET HEAD SCREW AND REMOVE OIL BAG RING. TURN OIL DIAPHRAGM INSIDE OUT AND REMOVE SMALL OIL CLAMP BY UNSCREWING SCREW. REMOVE OIL DIAPHRAGM. SLIDE OFF CAP FOR CIRCLIP, OUTER CIRCLIP FROM ROTOR SHAFT AND REMOVE LOWER MECHANICAL SEAL. BE VERY CAREFUL IN HANDLING THE TUNGSTEN CARBIDE SEAL FACE. LEAVE STATIONARY TUNGSTEN CARBIDE SEAT IN THE SEAL HOUSING. UNSCREW FOUR NUTS AND PULL OUT SEAL HOUSING. THE STATIONARY TUNGSTEN CARBIDE SEAL FACE WILL COME OUT WITH THE SEAL HOUSING. HANDLE THE FACE CAREFULLY. THE UPPER MECHANICAL SEAL IS NOW IN VIEW. REMOVE THE UPPER SEAL IN THE SAME WAY AS THE LOWER SEAL.

10. REMOVE THE FOUR NOS. DEEP SEATED CAP SCREWS THAT HOLD THE LOWER BEARING BRACKET AGAINST THE INNER CASING. THERE ARE FOUR NOS. TAPPED THROUGH HOLES IN THE LOWER BEARING BRACKET. THE LOWER BRACKET COMPLETE WITH THE ROTOR, BEARING, BEARING COVER AND TUNGSTEN CARBIDE SEAT WILL COME OUT WITH THE LOWER BEARING BRACKET. REMOVE BOLTS AND REMOVE BEARING COVER. PULL OUT ROTOR WITH BEARING FROM LOWER BEARING BRACKET. (IF THIS IS DIFFICULT USE A HAND PRESS TO REMOVE ROTOR FROM BEARING BRACKET. ENSURE NO DAMAGE TO THE TUNGSTEN CARBIDE SEAT IN BEARING BRACKET). THE TC SEAT WITH CUP SEAL HOLDER CAN NOW BE PUSHED OUT FROM THE BEARING SIDE BY GENTLY TAPPING THE SAME. (USE FINGERS OR A NYLON TIPPED LIGHT HAMMER ONLY).

11. CHECK BOTH UPPER AND LOWER BEARINGS FOR ANY RADIAL OR AXIAL PLAY OR ANY ABNORMAL NOISE WHILE SPINNING THE SAME. CHECK FOR ANY LEAKAGE OF GREASE THROUGH THE SHIELD OF THE UPPER BEARING. IF BEARING SEEMS WORN OUT OR ANY GREASE LEAKAGE IS OBSERVED, REPLACE BEARING. (DO NOT USE ANY STANDARD BEARING PROCURED FROM THE MARKET. THE PUMPS USE BEARINGS WHICH ARE PRE-FILLED WITH A SPECIAL HIGH TEMPERATURE GREASE AVAILABLE FROM US READILY).

12. THE TOP BRACKET IS HELD IN POSITION BY FOUR STUD BOLTS ON THE INNER CASING. UNSCREW THE NUTS AND REMOVE THE INNER CASING. ALTERNATIVELY TWO SCREWDRIVERS MAY BE USED TO PRY THE TOP BRACKET FROM THE STATOR.

13. THE STATOR IS SHRINK-FITTED IN THE INNER CASING. THE STATOR CAN NOW BE CHECKED FOR ANY ELECTRICAL FAULTS.



## **RE-ASSEMBLY OF THE PUMPSET.**

THE PUMP CAN BE RE-ASSEMBLED AS PER PROCEDURE GIVEN BELOW. PLEASE HOWEVER NOTE THE FOLLOWING:

- A) ALWAYS REPLACE NEW O-RINGS AND DISCARD OLD ONES.
- B) REPLACE NEW LOCK WASHER WHEN RE-ASSEMBLING.

1. THE CHECKED/REPAIRED STATOR IS KEPT UPRIGHT AND THE TOP BRACKET IS AFFIXED THROUGH THE FOUR BOLTS.

2. ALL THE ELECTRICAL CONNECTIONS OF THE STATOR LEAD WIRES AND EARTHING WIRE SHOULD BE SECURE AND INSULATED.

3. SLIDE BEARING COVER ON ROTOR SHAFT.

4. FIT BEARINGS (IF REMOVED OR REPLACED) ON ROTOR SHAFT (USE EITHER A HAND PRESS OR SHRINK THE SAME -- DO NOT HAMMER THE BEARINGS ON THE SHAFT-- YOU MAY SCORE/BEND THE SHAFT AND ALSO DAMAGE THE BEARINGS) AND FIT CIRCLIPS ON TOP AND BOTTOM GROOVES ON SHAFT. (IF THE BEARINGS ARE SHRINK FITTED ON THE SHAFT, HEAT THE BEARINGS IN OIL TO A MAXIMUM TEMPERATURE OF 120 DEGREES CELSIUS AS A HIGHER TEMPERATURE WILL LIQUEFY THE GREASE IN THE BEARING AND RENDER THE SAME UNUSABLE). DO NOT REUSE OLD BEARINGS THAT HAVE BEEN PULLED OFF.

5. SLIDE LOWER BEARING BRACKET ON TO LOWER BEARING AND ALIGN FOUR NOS. HOLES ON BEARING COVER WITH THE TAPPED HOLES ON LOWER BEARING BRACKET. FIT THE BOLTS AND TIGHTEN BEARING COVER.

6. FIT COMPLETE ROTOR ASSEMBLY IN STATOR HOUSING GUIDING UPPER BEARING IN TOP BEARING BRACKET SEAT. TIGHTEN BOLTS. FIT UPPER TC SEAT IN LOWER BEARING BRACKET (LIGHTLY OIL THE RUBBER SEAT CUP -- ENSURE THE SEAT SITS SQUARE IN THE BRACKET) AND SLIDE ON UPPER SEAL ASSEMBLY ON ROTOR SHAFT. LIGHTLY OIL THE ROTOR SHAFT BEFORE PUSHING BELLOWS ON SHAFT. USE EXTREME CARE SO THAT THE SEAL FACES ARE NOT DAMAGED. SLIDE ON CIRCLIP AND FIT IN GROOVE ON SHAFT.

7. PRESS HOME BY HAND LOWER SEAL TUNGSTEN CARBIDE SEAT INTO SEAL HOUSING. LIGHTLY OIL THE RUBBER SEAT CUP BEFORE PRESSING IN CAVITY. THE SEAT MUST SIT SQUARE IN THE HOUSING.

8. FIT SEAL HOUSING INTO LOWER BRACKET AND TIGHTEN NUTS.

9. SLIDE ON LOWER SEAL ASSEMBLY ON SHAFT. APPLY LIGHT COAT OF OIL ON SHAFT BEFORE SLIDING BELLOWS ON THE SAME. (USE SAME SEAL MANDREL AS USED FOR THE UPPER SEAL TO SLIDE BELLOWS ON SHAFT). FIT CIRCLIP AS FOR THE UPPER SEAL ASSEMBLY AND INSTALL CAP FOR CIRCLIP.

10. PRESS SAND GUARD INTO SEAL HOUSING (USE A HAND PRESS OR USE A NYLON HAMMER)

11. TURN OIL BAG INSIDE OUT AND FIT OIL BAG "VEE" SECTION INTO GROOVE IN SEAL HOUSING. USING SMALL OIL BAG CLAMPS AND SCREWS & NUTS, CLAMP THE OIL BAG TO THE SEAL HOLDER. TURN OIL BAG TO CLAMP THE LARGER SIDE "O" SECTION INTO THE GROOVE IN THE LOWER BEARING BRACKET IN THE SAME WAY. COMPRESS THE OIL BAG AND SLIDE THE OIL BAG RING OVER THE OIL BAG TILL IT SEATS AGAINST THE LOWER BEARING BRACKET. ALIGN THE FOUR HOLES IN THE OIL BAG RING WITH THE TAPPED HOLES IN THE LOWER BEARING BRACKET AND TIGHTEN THE OIL BAG RING WITH THE HELP OF THE SOCKET HEAD CAP SCREWS.

12. FIT ONE DRAIN PLUG WITH "O" RING IN LOWER BEARING BRACKET AND FILL OIL IN THE OIL BAG. PERIODICALLY PRESS THE OIL BAG TO LET AIR ESCAPE SO THAT FILLING IS PROPER AND NO AIR IS ENTRAPPED IN THE OIL BAG. REPLACE PLUG WITH "O" RING.

13. SLIDE ON WEAR PLATE AGAINST LOWER BEARING BRACKET AND TIGHTEN THE SAME. FIT KEY ON THE SHAFT AND SLIDE ON IMPELLER. CLEARANCES BETWEEN IMPELLER AND WEAR PLATE CAN BE ADJUSTED BY MEANS OF THE TRIMMING SPACERS. SLIDE ON LOCK WASHER ENSURING THAT TONGUE OF LOCK WASHER IS IN GROOVE OF THREADING AND TIGHTEN NUT. BEND LOCK WASHER OVER ANY SIDE OF THE HEX NUT. ENSURE THAT ROTOR SHAFT IS ROTATING FREE.

14. FIT OUTER CASING ON TOP BRACKET WITH "O" RING. FIT DIFFUSER RING AND DIFFUSER HOLDER AND TIGHTEN NUTS. FIT DIFFUSER CENTER AND ADJUST CLEARANCE BETWEEN IMPELLER AND DIFFUSER CENTER TO THE MINIMUM BY USING TRIMMING WASHERS. FIX STRAINER, BASE PLATE AND TIGHTEN BOLTS.

### **OIL SPECIFICATIONS**

- A) EXXON UNIVOLT 61
- B) SHELL TELLUS 29.
- C) CHEVRON SUPERLA FDA APPROVED # 10

### **USE NON-CONDUCTING, NON-FOAMING, NON-DETERGENT OIL ONLY**

### **PARTS CATALOG.**

#### **1. COMPONENTS LIST : AS PER DRAWING NO. DW/042/00 (SHEETS 1 & 2) AND DW/043/00 (SHEETS 1 & 2)**

#### **DRAWINGS :**

- 1. SECTIONAL ASSEMBLY DRG. NO.DW/042-043/00 (SHEET 1)
- 2. SEALING ARRANGEMENT WITH MATERIAL PARTS LIST NO. DW/042-043/00 (SHEET 2)

#### **R: RECOMMENDED SPARES FOR TWO YEARS OPERATION**

| <b><u>SR.NO</u></b> | <b><u>DESCRIPTION</u></b> | <b><u>PART NO.</u></b> | <b><u>QTY.</u></b> |
|---------------------|---------------------------|------------------------|--------------------|
| 1.                  | MECHANICAL SEAL           | 535-020-00             | 2 NO.              |
| 2.                  | "O" RING SET              | 375-025-66             | 2 SETS.            |
| 3.                  | CABLE GROMMET             | 260-066-66             | 2 NOS.             |
| 4.                  | CABLE LEAD GROMMET 4 HOLE | 260-104-66             | 2 NOS.             |
| 5.                  | UPPER BEARING             | 020-007-07             | 1 NO.              |
| 6.                  | LOWER BEARING             | 020-009-07             | 1 SET.             |
| 7.                  | IMPELLER(G702T/60 HZ)     | 300-054-22             | 1 NO.              |
| 8.                  | DIFF. CENTER(G702T)       | 155-001-80             | 1 NO.              |
| 9.                  | DIFFUSER RING(G702T)      | 170-002-80             | 1 NO.              |
| 10.                 | WEAR PLATE                | 715-015-80             | 1 NO.              |
| 11.                 | LOCK WASHER               | 695-005-21             | 2 NOS.             |

**PLEASE CHOOSE IMPELLER/DIFFUSER SET ACCORDING TO PUMP MODEL & FREQUENCY.**

# WINDING DIAGRAM FOR 2 POLE DUAL VOLTAGE MOTOR DEWATERING PUMPS (12 LEADS)

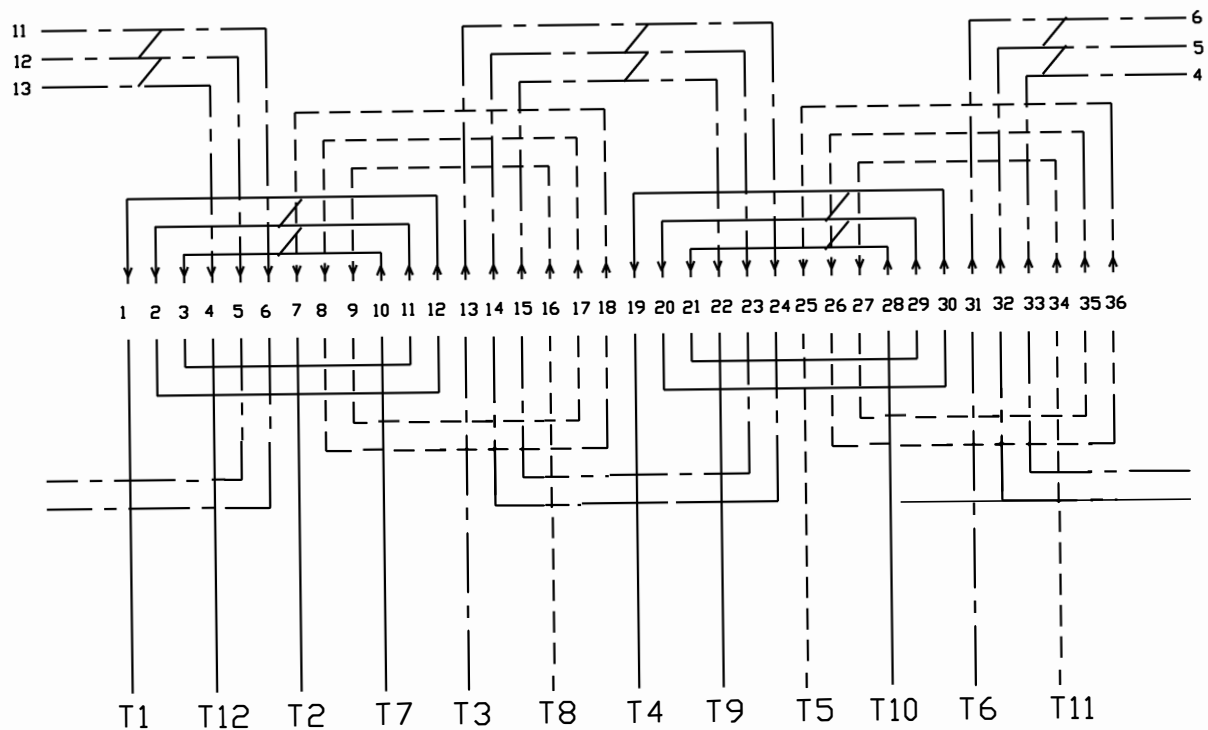

CONNECT AND SOLDER

|    |        |     |                |
|----|--------|-----|----------------|
| T1 | RED    | T7  | WHITE (RED)    |
| T2 | YELLOW | T8  | WHITE (YELLOW) |
| T3 | BLUE   | T9  | WHITE (BLUE)   |
| T4 | GREEN  | T10 | WHITE (GREEN)  |
| T5 | BLACK  | T11 | WHITE (BLACK)  |
| T6 | GREY   | T12 | WHITE (GREY)   |

460 VOLTS CONN.  
JOIN PERMANENTLY

T7 & T10  
T8 & T11  
T9 & T12

LINE  
L1 = T1 T6  
L2 = T2 T4  
L3 = T3 T5

230 VOLTS CONN.

L1 = T1 T6 T9 T10  
L2 = T2 T4 T7 T11  
L3 = T3 T5 T8 T12

## CONNECTION DIAGRAM: - 36-02-06-D/Y 900

NO. OF SLOTS                                      36      NO.OF POLES                                      2

NO. OF COILS/GROUP                            3      NO. OF GROUPS                                    6

PITCH                      1-14, 16, 18   SINGLE -CONCENTRIC

575V/1000V/50/60 Hz

NO. OF LEADS – 6 LEADS OUT

| TOP | BOTTOM | TOP | BOTTOM | LEAD      | COLOUR        |
|-----|--------|-----|--------|-----------|---------------|
| 1   |        |     |        | <b>T1</b> | <b>RED</b>    |
|     | 1      |     | 4      |           |               |
|     |        | 4   |        | <b>T4</b> | <b>GREEN</b>  |
| 3   |        |     |        | <b>T3</b> | <b>YELLOW</b> |
|     | 3      |     | 6      |           |               |
|     |        | 6   |        | <b>T6</b> | <b>BLACK</b>  |
| 5   |        |     |        | <b>T5</b> | <b>BLUE</b>   |
|     | 5      |     | 2      |           |               |
|     |        | 2   |        | <b>T2</b> | <b>GREY</b>   |

**FOR 575 VOLTS: - DELTA CONNECTION**

1. JOIN T1+T2 CONNECT L1
2. JOIN T3+T4 CONNECT L2
3. JOIN T5+T6 CONNECT L3

**FOR 1000 VOLTS: - STAR CONNECTION**

1. JOIN T2+T4+T6 PERMANENTLY
2. CONNECT L1-T1, L2-T3, L3-T5.

**DRUM TEST:-**

Direction of rotation clockwise from lead wire side.

*CON36S2P-575V/1000V*

This copy belongs to Mody Pumps Inc. and is strictly confidential. Do not circulate this copy without Mody pumps authorization.

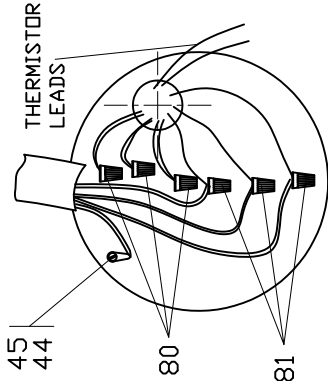
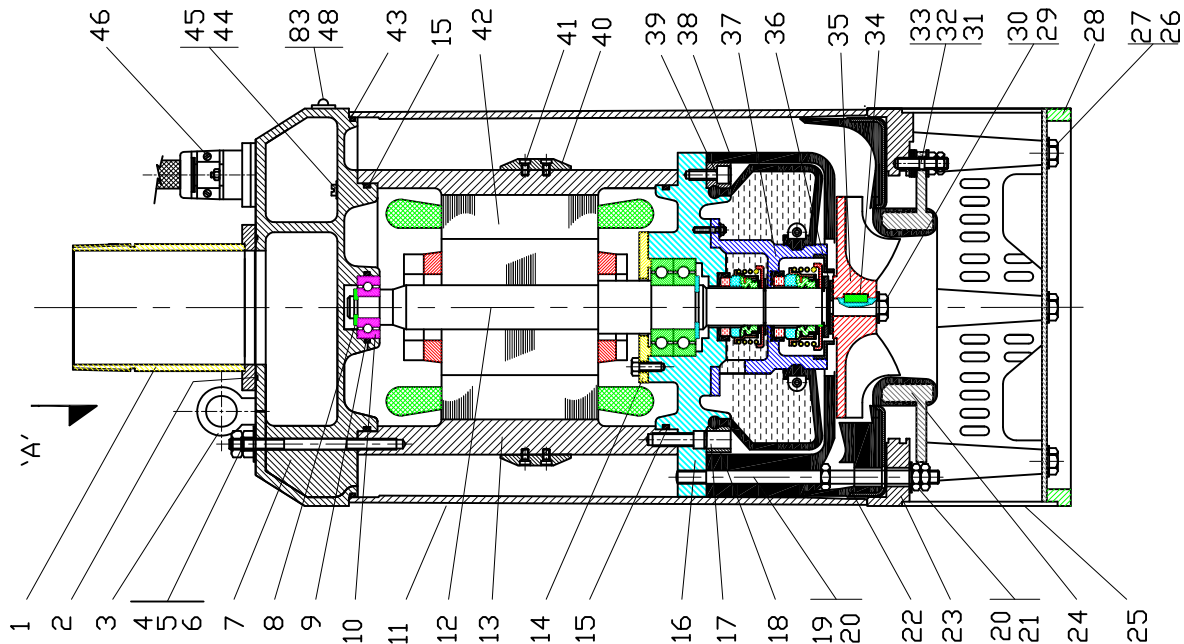

VIEW FROM 'A'

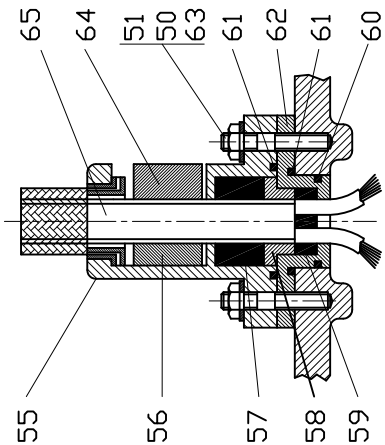

SECTION AT 'Y-Y'  
(CABLE GLAND ASSY.)

VIEW AT 'X-X'

(4 CORE CABLE CONNECTIONS)

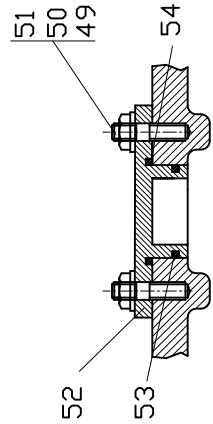

SECTION AT 'Z-Z'  
(BLANK CAP ASSY.)



Mody Pumps Inc.  
2166 Zeus Court  
Bakersfield, CA 93308 USA  
Tel: 661-392-7600 Fax: 661-392-7601  
www.modypump.com

|           |                  |          |           |          |
|-----------|------------------|----------|-----------|----------|
| MODEL:    | G702TME          | DRN.     | V V K     | 25/12/07 |
| SCALE:    | NTS              | CHKD.    |           |          |
| QTY:      | 1NO.             | APPD.    |           |          |
| TITLE:    | GENERAL ASSEMBLY | CODE No. | DW\042\00 | REV. 0   |
| MATERIAL: | -                |          |           |          |
| DRAWING   |                  |          |           |          |

This copy belongs to Mody Pumps Inc. and is strictly confidential. Do not circulate this copy without Mody pumps authorization.

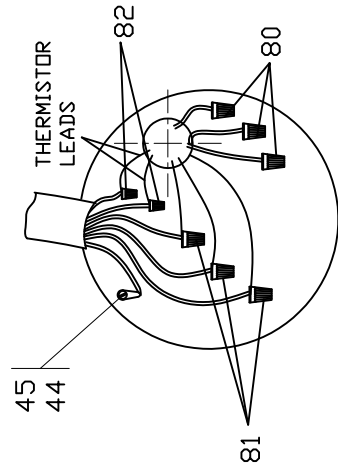

CONNECTIONS AT 'X-X'  
(6 CORE CABLE CONNECTIONS)

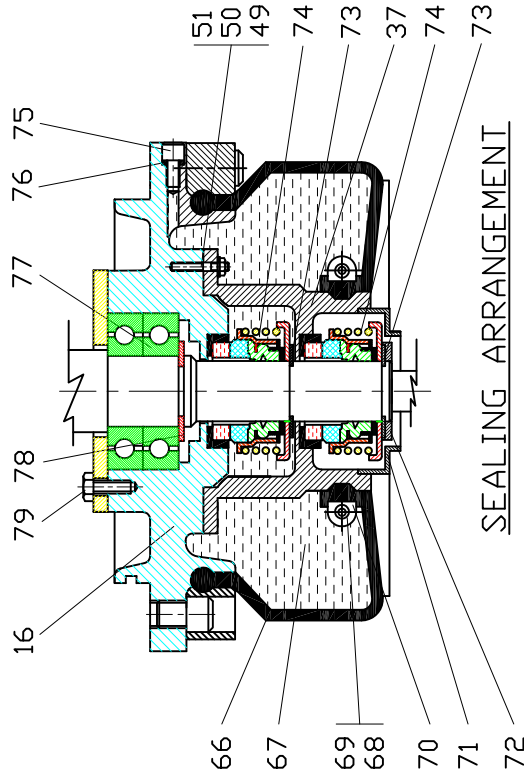

SEALING ARRANGEMENT



Mody Pumps Inc.  
2186 Zeus Court  
Bakersfield, CA 93308 USA  
Tel: 661-392-7600 Fax: 661-392-7601  
www.modypump.com

|        |         |           |  |       |       |          |
|--------|---------|-----------|--|-------|-------|----------|
| MODEL: | G702TME | MATERIAL: | —  | DRN.  | V V K | 25/12/07 |
| SCALE: | NTS     | TITLE:    | MATERIAL PARTS FOR<br>GENERAL ASSEMBLY DRAWING | CHKD. |       |          |
| QTY:   | 1NO.    | CODE No.  | DW\042\00                                      | APPD. |       |          |
|        |         | REV.      | 0  |       |       |          |

## PUMP MODEL G702TM

1.1.2012

| Sr.NO. | PART No.               | DESCRIPTION  | QTY |
|--------|------------------------|--|-----|
| 1a     | 405-057-21             | DISCHARGE OUTLET (6" NPT)                          | 1   |
| 1b     | 405-109-21             | DISCHARGE OUTLET (6" BSPT)                         | 1   |
| 1c     | 405-050-21             | DISCHARGE OUTLET (6" HOSE)                         | 1   |
| 2      | 380-029-66             | "O" RING   | 1   |
| 3      | 270-010-21             | LIFTING HOOK                                       | 2   |
| 4      | 650-062-21             | STUD   | 4   |
| 5      | 370-019-21             | HEX NUT  | 8   |
| 6      | 700-009-21             | WASHER   | 4   |
| 7      | 035-072-30             | TOP BRACKET  | 1   |
| 8      | 080-005-08             | CIRCLIP  | 1   |
| 9      | 380-015-66             | "O" RING   | 1   |
| 10     | 020-007-07             | UPPER BEARING                                      | 1   |
| 11     | 400-043-04             | OUTER CASING                                       | 1   |
| 12     | 480-074-00             | ROTOR COMPLETE                                     | 1   |
| 13     | 625-049-33             | STATOR CASING                                      | 1   |
| 14     | 037-004-30             | BEARING COVER                                      | 1   |
| 15     | 380-033-66             | "O" RING   | 2   |
| 16     | 035-077-30             | LOWER BEARING BRACKET                              | 1   |
| 17     | 520-004-21             | CAP SCREW  | 4   |
| 18     | 385-003-30             | OIL BAG RING                                       | 1   |
| 19     | 650-101-21             | STUD   | 4   |
| 20     | 370-009-21             | HEX NUT  | 12  |
| 21     | 700-008-21             | WASHER   | 4   |
| 22     | 170-002-80             | DIFFUSER RING (G702T)                              | 1   |
| 23     | 160-003-01             | DIFFUSER HOLDER                                    | 1   |
| 24     | 155-013-80             | DIFFUSER CENTRE (G702T)                            | 1   |
| 25     | 640-014-21             | STRAINER   | 1   |
| 26     | 045-016-21             | HEX HD BOLT  | 6   |
| 27     | 705-001-21             | SPRING WASHER                                      | 6   |
| 28     | 030-009-04             | BASE PLATE   | 1   |
| 29     | 365-023-21             | LOCK NUT   | 1   |
| 30     | 695-005-21             | LOCK WASHER  | 1   |
| 31     | 650-020-21             | STUD   | 8   |
| 32     | 370-008-21             | HEX NUT  | 12  |
| 33     | 700-006-21             | WASHER   | 28  |
| 34     | 320-012-22             | KEY  | 1   |
| 35a    | 300-053-22             | IMPELLER (50Hz)                                    | 1   |
| 35b    | 300-054-22             | IMPELLER (60Hz)                                    | 1   |
| 36     | 600-022-21             | TRIMMING SPACER                                    | 3   |
| 37     | 545-004-45             | SEAL HOUSING                                       | 1   |
| 38     | 715-015-80             | WEAR PLATE   | 1   |
| 39     | 520-006-22             | CAP SCREW  | 4   |
| 40     | 010-005-26             | ZINC ANODE   | 4   |
| 41     | 520-008-21             | CAP SCREW  | 8   |
| 42     | 619-101-00/ 619-106-00 | BARE STATOR 12 LEAD (230/460v)/ BARE STATOR (575V) | 1   |
| 43     | 380-041-66             | "O" RING   | 1   |
| 44     | 525-019-21             | EARTHING SCREW                                     | 1   |
| 45     | 740-002-46             | CABLE LUG  | 1   |
| 46     | 525-012-21             | CH. HD. SCREW                                      | 2   |
| 47     | 350-022-21             | NAME PLATE (CD)                                    | 1   |
| 48     | 465-006-21             | RIVET  | 6   |
| 49     | 650-011-21             | STUD   | 6   |
| 50     | 370-006-21             | HEX NUT  | 8   |
| 51     | 700-004-21             | WASHER   | 8   |
| 52     | 430-018-45             | BLANK CAP  | 1   |
| 53     | 380-005-66             | "O" RING   | 1   |
|        | ** 600-103-21          | BEARING SHIM SPACER (IF NEEDED)                    | 1   |

## PUMP MODEL G702TM

1.1.2012

| Sr.NO. | PART No.   | DESCRIPTION                              | QTY |
|--------|------------|--|-----|
| 54     | 380-010-66 | "O" RING                                 | 1   |
| 55     | 660-101-00 | GLAND WITH GRIP ASSY. (Order with Gland) | 1   |
| 56     | 662-007-66 | CABLE SUPPORT                            | 1   |
| 57     | 260-066-66 | CABLE GROMMET                            | 1   |
| 58a    | 600-066-40 | Spacer for Gland - 4 Core Cable          | 1   |
| 58b    | 600-068-40 | Spacer for Gland - 6 Core Cable          | 1   |
| 59a    | 260-104-66 | CABLE LEAD GROMMET- 4 Core Cable         | 1   |
| 59b    | 260-071-66 | CABLE LEAD GROMMET- 6 Core Cable         | 1   |
| 60     | 380-009-66 | "O" RING                                 | 1   |
| 61     | 380-083-66 | "O" RING                                 | 2   |
| 62a    | 235-018-21 | CABLE GLAND BASE 4 HOLE                  | 1   |
| 62     | 235-019-21 | CABLE GLAND BASE 6 HOLE                  | 1   |
| 63     | 650-013-21 | STUD                                     | 2   |
| 64     | 085-006-21 | CABLE CLAMP                              | 1   |
| 65a    | 065-031-79 | CABLE W 08/4 SOOW                        | 50' |
| 65b    | 065-025-79 | CABLE 6sq.mm 6 core                      | 50' |
| 66     | 150-005-66 | OIL DIAPHRAGM                            | 1   |
| 67     | 395-005-93 | OIL                                      | 5   |
| 68     | 370-002-21 | HEX NUT                                  | 4   |
| 69     | 525-022-21 | PH. HD. PAN SCREW                        | 2   |
| 70     | 085-004-21 | OIL BAG CLAMP (SMALL)                    | 2   |
| 71     | 515-006-21 | SAND GUARD                               | 1   |
| 72     | 600-036-21 | CAP FOR CIRCLIP                          | 1   |
| 73     | 080-007-21 | CIRCLIP                                  | 2   |
| 74     | 535-020-00 | MECHANICAL SEAL                          | 2   |
| 75     | 520-002-21 | OIL PLUG                                 | 2   |
| 76     | 380-001-66 | "O" RING                                 | 2   |
| 77     | 020-009-07 | LOWER BEARING                            | 2   |
| 78     | 080-010-08 | CIRCLIP                                  | 1   |
| 79     | 045-008-21 | HEX HD BOLT                              | 4   |
| 80     | 365-025-00 | WIRE NUT CONNECTOR                       | 3   |
| 81     | 365-027-00 | WIRE NUT CONNECTOR                       | 3   |
| 82     | 365-026-00 | WIRE NUT CONNECTOR                       | 3   |
| 83     | 635-009-21 | ROTATION ARROW                           | 1   |
| 84     | 375-025-66 | "O" RING SET                             | 1   |



This copy belongs to Mody Pumps Inc. and is strictly confidential. Do not circulate this copy without Mody pumps authorization.

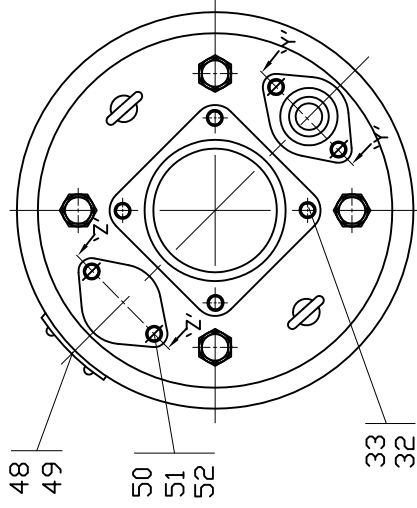
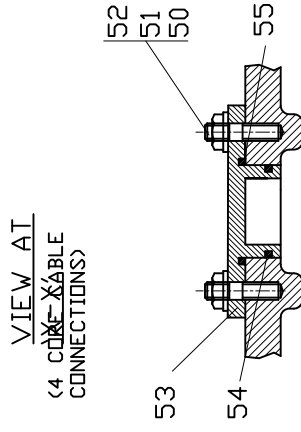
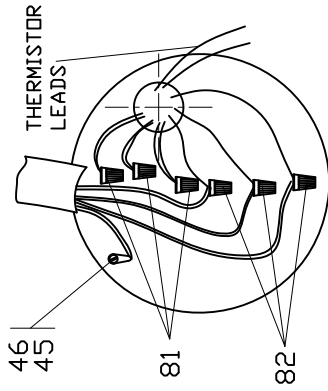
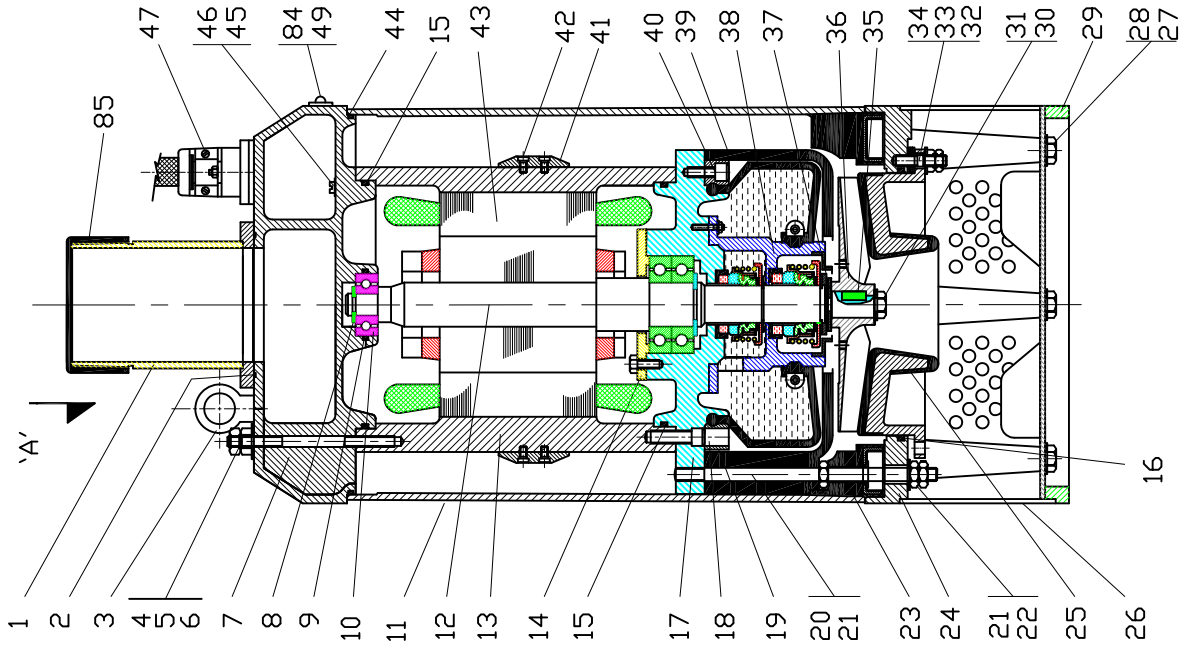

VIEW FROM 'A'

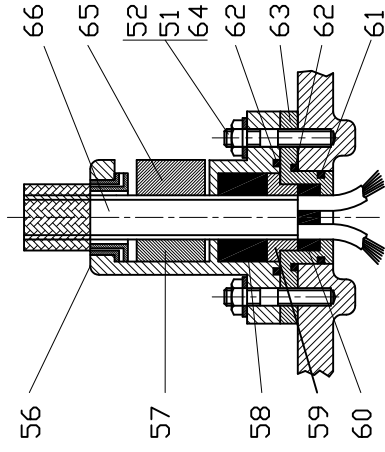

SECTION AT 'Y-Y' (CABLE GLAND ASSY.)



Mody Pumps Inc.  
2166 Zeus Court  
Bakersfield, CA 93308 USA  
Tel.: 661-392-7600 Fax: 661-392-7601  
www.modypump.com

|                         |         |          |           |          |
|-------------------------|---------|----------|-----------|----------|
| MODEL:                  | G706TME | DRN.     | V V K     | 14/04/09 |
| SCALE:                  | NTS     | QTY.     |           |          |
|                         | 1NO.    | APPD.    |           |          |
| TITLE: GENERAL ASSEMBLY |         | CODE No. | DW\043\00 |          |
| DRAWING                 |         | REV.     | 0         |          |

This copy belongs to Mody Pumps Inc. and is strictly confidential. Do not circulate this copy without Mody pumps authorization.

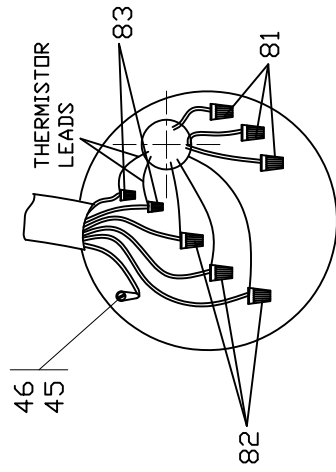

CONNECTIONS AT 'X-X'  
(6 CORE CABLE CONNECTIONS)

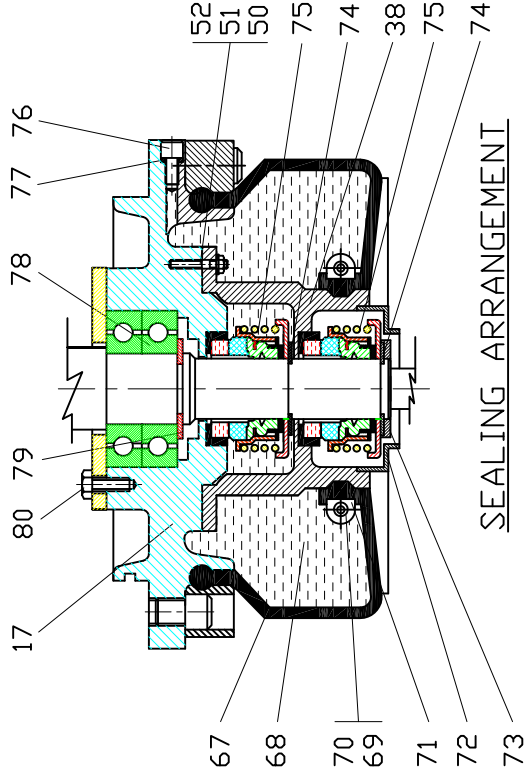

Mody Pumps Inc.  
2166 Zeus Court  
Bakersfield, CA 93308 USA  
Tel.: 661-392-7600 Fax: 661-392-7601  
www.modypump.com

|        |         |           |  |       |       |          |
|--------|---------|-----------|--|-------|-------|----------|
| MODEL: | G706TME | MATERIAL: | —  | DRN.  | V V K | 14/04/09 |
| SCALE: | NTS     | TITLE:    | MATERIAL PARTS FOR<br>GENERAL ASSEMBLY DRAWING | CHKD. |       |          |
| QTY.   | 1NO.    | CODE No.  | DW\043\00                                      | APPD. |       |          |
|        |         | REV.      | 0  |       |       |          |

## PUMP MODEL G706TM

1.1.2012

| Sr.NO. | PART No.   | DESCRIPTION                    | QTY |
|--------|------------|--------------------------------|-----|
| 1a     | 405-061-21 | DISCHARGE OUTLET (4" NPT)      | 1   |
| 1b     | 405-110-21 | DISCHARGE OUTLET (4" BSPT)     | 1   |
| 1c     | 405-100-21 | DISCHARGE OUTLET (4" HOSE)     | 1   |
| 2      | 380-029-66 | "O" RING                       | 1   |
| 3      | 270-010-21 | LIFTING HOOK                   | 2   |
| 4      | 650-062-21 | STUD                           | 4   |
| 5      | 370-019-21 | HEX NUT                        | 8   |
| 6      | 700-009-21 | WASHER                         | 4   |
| 7      | 035-072-30 | TOP BRACKET                    | 1   |
| 8      | 080-005-08 | CIRCLIP                        | 1   |
| 9      | 380-015-66 | "O" RING                       | 1   |
| 10     | 020-007-07 | UPPER BEARING                  | 1   |
| 11     | 400-043-04 | OUTER CASING                   | 1   |
| 12     | 480-074-00 | ROTOR COMPLETE                 | 1   |
| 13     | 625-049-33 | STATOR CASING                  | 1   |
| 14     | 037-004-30 | BEARING COVER                  | 1   |
| 15     | 380-033-66 | "O" RING                       | 2   |
| 16     | 380-037-66 | "O" RING                       | 1   |
| 17     | 035-077-30 | LOWER BEARING BRACKET          | 1   |
| 18     | 520-004-21 | CAP SCREW                      | 4   |
| 19     | 385-003-30 | OIL BAG RING                   | 1   |
| 20     | 650-101-21 | STUD                           | 4   |
| 21     | 370-009-21 | HEX NUT                        | 12  |
| 22     | 700-008-21 | WASHER                         | 4   |
| 23     | 170-003-80 | DIFFUSER RING (G706T)          | 1   |
| 24     | 160-003-01 | DIFFUSER HOLDER                | 1   |
| 25     | 155-005-80 | DIFFUSER CENTRE (G706T)        | 1   |
| 26     | 640-019-21 | STRAINER                       | 1   |
| 27     | 045-016-21 | HEX HD BOLT                    | 6   |
| 28     | 705-001-21 | SPRING WASHER                  | 6   |
| 29     | 030-009-04 | BASE PLATE                     | 1   |
| 30     | 365-023-21 | LOCK NUT                       | 1   |
| 31     | 695-005-21 | LOCK WASHER                    | 1   |
| 32     | 650-020-21 | STUD                           | 8   |
| 33     | 370-008-21 | HEX NUT                        | 12  |
| 34     | 700-006-21 | WASHER                         | 28  |
| 35     | 320-012-22 | KEY                            | 1   |
| 36a    | 300-056-22 | IMPELLER (50Hz)                | 1   |
| 36b    | 300-057-22 | IMPELLER (60Hz)                |     |
| 37     | 600-022-21 | TRIMMING SPACER                | 3   |
| 38     | 545-004-45 | SEAL HOUSING                   | 1   |
| 39     | 715-015-80 | WEAR PLATE                     | 1   |
| 40     | 520-006-22 | CAP SCREW                      | 4   |
| 41     | 010-005-26 | ZINC ANODE                     | 4   |
| 42     | 520-008-21 | CAP SCREW                      | 8   |
| 43     | 619-101-00 | BARE STATOR 12 LEAD (230/460v) | 1   |
| 44     | 380-041-66 | "O" RING                       | 1   |
| 45     | 525-019-21 | EARTHING SCREW                 | 1   |
| 46     | 740-002-46 | CABLE LUG                      | 1   |
| 47     | 525-012-21 | CH. HD. SCREW                  | 2   |
| 48     | 350-022-21 | NAME PLATE (CD)                | 1   |
| 49     | 465-006-21 | RIVET                          | 6   |
| 50     | 650-011-21 | STUD                           | 6   |
| 51     | 370-006-21 | HEX NUT                        | 8   |
| 52     | 700-004-21 | WASHER                         | 8   |
| 53     | 430-018-45 | BLANK CAP                      | 1   |





# *LIMITED WARRANTY*

We warrant to our immediate customer and to the ultimate consumer that products of our manufacture will be free of defects in material and workmanship under normal use and service for the following time periods, when installed and maintained in accordance with our instructions.

PUMPS: One (1) year from date of installation or (18) months from date of shipment, whichever occurs first. As used herein, "the ultimate consumer" is defined as the purchaser who first uses the product after its initial installation or, in the case for product designed for non-permanent installation, the first owner who uses the product. It is the purchaser's or any sub-vendor's obligation to make known to the ultimate consumer the terms and conditions of this warranty. This warranty gives you specific legal rights, and there may also be other rights which vary from state to state. In the event the product is covered by the Federal Consumer Product Warranties Law (1) the duration of any implied warranties associated with the product by virtue of said law is limited to the same duration as stated herein, (2) this warranty is a LIMITED WARRANTY, and (3) no claims of any nature whatsoever shall be made against us, until the ultimate consumer, his successor, or assigns, notifies us in writing of the defect, and delivers the product and/or defective part(s) freight prepaid to our facility or nearest authorized service station. Some states do not allow limitations on how long an implied warranty lasts, so the above limitation may not apply. **THE SOLE AND EXCLUSIVE REMEDY FOR BREACH OF ANY AND ALL WARRANTIES WITH RESPECT TO ANY PRODUCT SHALL BE TO REPLACE OR REPAIR AT OUR ELECTION, FOB POINT OF MANUFACTURE OR AUTHORIZED REPAIR STATION, SUCH PRODUCTS AND/OR PARTS AS PROVEN DEFECTIVE. THERE SHALL BE NO FURTHER LIABILITY, WHETHER BASED ON WARRANTY, NEGLIGENCE OR OTHERWISE.**

Unless expressly stated otherwise, guarantees in the nature of performance specifications furnished in addition to the foregoing material and workmanship warranties on a product manufactured by *Mody*, if any, are subject to laboratory tests corrected for field performance. Any additional guarantees, in the nature of performance specifications must be in writing and such writing must be signed by our authorized representative. Due to inaccuracies in field testing if a conflict arises between the results of field testing conducted by or for user, and laboratory tests corrected for field performance, the latter shall control. Components or accessories supplied by us but manufactured by others are warranted only to the extent of and by the terms and conditions of the original manufacturer's warranty.

**RECOMMENDATIONS FOR SPECIAL APPLICATIONS OR THOSE RESULTING FROM SYSTEMS ANALYSES AND EVALUATIONS WE CONDUCT, WILL BE BASED ON OUR BEST AVAILABLE EXPERIENCE AND PUBLISHED INDUSTRY INFORMATION. SUCH RECOMMENDATIONS DO NOT CONSTITUTE A WARRANTY OF SATISFACTORY PERFORMANCE AND NO SUCH WARRANTY IS GIVEN.**

This warranty shall not apply when damage is caused by (a) improper installation, (b) improper voltage, (c) lightning, (d) sand or other abrasive materials, (e) scale or corrosion build-up due to excessive chemical content. Any modification of the equipment will also void the warranty. We will not be responsible for loss, damage or labor cost due to interruption of service caused by defective parts. Neither will we accept charges incurred by others without our prior written approval. This warranty is void if our inspection reveals the product was used in a manner inconsistent with normal industry practice and/or our specific recommendations. The purchaser is responsible for communication of all necessary information regarding the application and use of the product. **UNDER NO CIRCUMSTANCES WILL WE BE RESPONSIBLE FOR ANY OTHER DIRECT OR CONSEQUENTIAL DAMAGES, INCLUDING BUT NOT LIMITED TO LOST PROFITS, LOST INCOME, LABOR CHARGES, DELAYS IN PRODUCTION, IDLE PRODUCTION, WHICH DAMAGES ARE CAUSED BY ANY DEFECTS IN MATERIAL, AND/OR WORKMANSHIP AND/OR DELAYS IN SHIPMENT. THIS WARRANTY IS EXPRESSLY IN LIEU OF ANY OTHER EXPRESS OR IMPLIED WARRANTY, INCLUDING ANY WARRANTY OF MERCHANTABILITY OR FITNESS FOR A PARTICULAR PURPOSE.**

No rights extended under this warranty shall be assigned to any person, whether by operation or otherwise, without our prior written approval.