



MODELS: M-0.5, M-1, M-2

**OPERATING INSTRUCTIONS, INSTALLATION & MAINTENANCE
MANUAL INCLUDING SPARE PARTS LIST**



Mody Pumps Inc.

2166 Zeus Court

Bakersfield, CA 93308

Tel.: (661) 392-7600 FAX.: (661) 392-7601

EMAIL: sales@modypump.com

<http://www.modypump.com>



ISO 9001 Certified



LIFE IS PRECIOUS - THINK SAFETY

1. Most accidents can be avoided by using COMMON SENSE.
2. Please read the operation and maintenance instruction manual supplied with the pump. If you did not receive one, please call your local distributor before pump installation.
3. Do not wear loose apparel that may become entangled in the impeller or other moving parts.
4. Always use appropriate safety equipment, such as safety glasses, when working on the pump or piping.
5. Pumps build up heat and pressure during operation-allow time for pumps to cool before handling or servicing.
6. Only qualified service personnel should install, operate and repair pump.
7. Keep clear of suction and discharge openings. DO NOT insert fingers in pump with power connected.
8. Do not pump flammable or hazardous materials (gasoline, acids, alkalis, etc.)
9. Do not block or restrict discharge hose, as it may whip or burst catastrophically under pressure.
10. Make sure lifting handles/hooks are securely fastened each time before lifting.
11. Do not lift pump by the power cord under any circumstances.
12. Do not exceed manufacturer's recommendation for optimum performance, as this could cause the motor/pump to overheat and lead to premature wear or failure.
13. Secure the pump in its operating position so it does not tip over, fall or slide.
14. Keep away from impeller when power is connected.
15. Submersible Pumps are not approved for use in swimming pools, recreational water installations, decorative fountains or any installation where human contact with the pumped fluid is common.
16. Do not operate pump without adequate protection and safety devices in place.
17. Always replace safety devices that have been removed during service or repair.
18. To reduce risk of electrical shock, pump must be properly grounded in accordance with the National Electric Code and all applicable state and local codes and ordinances.
19. To reduce risk of electrical shock, always disconnect the pump from the power source before handling or servicing.
20. Any wiring of pumps should be performed by a qualified electrician.
21. Never operate a pump with a power cord that has frayed or brittle insulation.
22. Cable should be protected at all times to avoid punctures, cuts, and abrasions - inspect frequently.
23. Never handle connected - "hot" power cords with wet hands.
24. Never operate a pump with a plug-in type power cord without a ground fault circuit interrupter, adequate overload and short circuit protection.

IMPORTANT !!! MODY Pumps Inc. is not responsible for losses, injury, or death resulting from a failure to observe these safety precautions, misuse or abuse of pumps or equipment.

INTRODUCTION

THE *"mody"* MOTOR DRIVEN PORTABLE SUBMERSIBLE PUMPS HAVE BEEN DEVELOPED DUE TO A LONG FELT NEED OF HAVING A TRULY MAINTENANCE FREE PUMPSET FOR VARIOUS APPLICATIONS. THE PUMP IS A LIGHTWEIGHT, COMPACT UNIT ENABLING IT TO BE USED IN MOST SEA-CRAFT AND DIFFICULT LAND INSTALLATIONS. THE UNIT CONSISTS OF A VERTICAL CENTRIFUGAL PUMP WITH AN IN-BUILT SPLIT CAPACITOR START SQUIRREL CAGE, INDUCTION ELECTRIC MOTOR WHICH IS AVAILABLE FOR VARIOUS ELECTRIC SUPPLY CONFIGURATIONS. THE PUMPED WATER IS USED AS A COOLING MEDIUM WHICH COOLS THE ELECTRIC MOTOR. THE PUMPSET CAN ALSO BE USED IN ANY POSITION THUS MAKING IT IDEAL FOR DEWATERING IN DIFFICULT LOCATIONS.

THE SERVICE LIFE OF A SUBMERSIBLE PUMP DEPENDS MAINLY ON TWO THINGS: THE DEPENDABILITY OF THE SEALING SYSTEM AND THE WEAR RESISTANCE OF THE PUMP WEAR PARTS.

ALL *"mody"* SUBMERSIBLE SUMP PUMPS INCORPORATE A UNIQUE SEALING SYSTEM. THE CONSTRUCTION CONSISTS OF DOUBLE MECHANICAL SEALS, IMMERSED IN AN OIL BATH. THE COMPLETE PACKAGE IS A PRESSURE COMPENSATED SEALING DEVICE WHICH ENSURES A MINIMAL PRESSURE DIFFERENTIAL ACROSS THE SEAL FACES, IRRESPECTIVE OF THE DEPTH SETTING OF THE PUMP OR THE HEAD AGAINST WHICH THE PUMP IS OPERATING.

IN *"mody"* SUBMERSIBLE SUMP PUMPS, ALL WEAR PARTS ARE READILY REPLACEABLE AS NEEDED. BOTH WEAR AND ELECTRICITY CONSUMPTION ARE STILL FURTHER REDUCED WHEN THE PUMPS ARE FITTED WITH BUILT-IN LEVEL CONTROLS FOR AUTOMATIC STARTING AND STOPPING. **IT IS HOWEVER RECOMMENDED THAT IRRESPECTIVE OF TYPE OF PUMP, ADEQUATE MOTOR PROTECTION SWITCHGEAR SHOULD BE USED AT THE INSTALLATION. WE STRONGLY RECOMMEND THE USE OF SUITABLE CONTROL PANELS WHICH ARE AVAILABLE FROM US INCORPORATING ALL REQUIRED PROTECTION DEVICES.**

IT IS IN THE INTEREST OF THE USER THAT HE GO THROUGH THIS MANUAL IN DETAIL PRIOR TO USING THE PUMP. THE MANUAL WILL HELP HIM UNDERSTAND THE CONSTRUCTIONAL FEATURES AND TO OBTAIN TROUBLE FREE SERVICE FROM THE PUMP.

PURPOSE:

THE PUMP HAS BASICALLY BEEN DESIGNED AS A PLUG-IN DEWATERING UNIT TO PUMP OUT FLOODED INSTALLATIONS OR ANY CONDITIONS THAT NEED DEWATERING OF UNWANTED FLUIDS. THE PUMP HAS BEEN DESIGNED TO HANDLE WATER CONTAMINATED WITH OIL AS WELL AS ABRASIVE PARTICLES NORMALLY ASSOCIATED WITH RAW WATER. THE MAXIMUM SIZE OF PARTICLES THAT CAN BE HANDLED IS APPROX. 1/4". **THE MAXIMUM SPECIFIC GRAVITY OF THE PUMPED FLUID SHOULD NOT EXCEED 1.1.**

OVERALL DIMENSIONS AND WEIGHT.

	M-0.5	M-1	M-2
OVERALL HEIGHT	12.95"/329MM	14"/356MM	17"/432MM
MAX. DIAMETER	7.25"/184MM	7.25"/184MM	8.85"/225MM
MAX. WEIGHT	28LBS/12.7KGS	31LBS/14KGS	52LBS/23.6KGS

MAINTENANCE SERVICES REQUIRED.

THE FOLLOWING CHECKS TO BE DONE AT INTERVALS INDICATED BELOW:

1. CONDITION OF SEALS TO BE CHECKED AT EVERY 2500 HRS. OF OPERATION BY ASCERTAINING THE CONDITION OF OIL IN THE SEAL CHAMBER.

2. MONTHLY RUNNING OF PUMP FOR AT LEAST 5/10 MINUTES AND CHECKING OF AMPERES DRAWN AND INSULATION RESISTANCE. (MIN. INSULATION RESISTANCE 1 MEG. OHM AND MAX. CURRENT DRAWN AS PER NAME PLATE)

SAFETY PRECAUTIONS.

1. ENSURE THAT THE INSULATION RESISTANCE OF THE MOTOR IS AT LEAST 1 MEG. OHM BEFORE ENERGIZING THE UNIT.

2. CHECK THAT THE AVAILABLE POWER SUPPLY (VOLTAGE, PHASE, FREQUENCY) MATCHES WITH THE DETAILS ON THE PUMP NAMEPLATE.

3. ENSURE THAT THE GROUND WIRE IN THE 3 CORE CABLE SUPPLIED WITH THE PUMP IS SECURELY EARTHED.

4. ENSURE HOSE CONNECTION IS CORRECTLY AND SECURELY FITTED

5. ENSURE DELIVERY HOSE IS FREE FROM KINKS AND SHARP BENDS.

6. **DO NOT LIFT OR PULL THE PUMP UNDER ANY CIRCUMSTANCES BY MEANS OF THE CABLE.** THE PUMP MUST BE LOWERED/LIFTED FROM THE SPACE TO BE PUMPED BY USING A LIFTING ROPE ATTACHED TO THE HANDLE/EYEBOLT PROVIDED IN THE PUMP.

7. DRY RUNNING OF THE PUMP IS NOT DESIRABLE. HOWEVER THE PUMP WILL NOT BE DAMAGED OR SUFFER ANY ILL EFFECTS IF IT IS RUN DRY FOR SHORT PERIODS (UPTO APPROX. 30 MINUTES).

9. THE MAXIMUM PUMP SUBMERGENCE RECOMMENDED IS 50 FEET.

10. **THE SPECIFIC GRAVITY OF PUMPED FLUID SHOULD NOT EXCEED 1.1 UNDER ANY CIRCUMSTANCES.** PUMP IS DESIGNED TO OPERATE IN FLUIDS WITH pH from 5 - 8.

11. IF PUMP IS NOT USED AND LYING IN STORAGE FOR MORE THAN 30 DAYS PLEASE ENSURE THAT THE SEAL FACES ARE NOT GAUGE LOCKED - ROTATE THE IMPELLER/KICK START THE UNIT ONCE A MONTH. REFER TO INSTRUCTIONS ON DISASSEMBLY/REASSEMBLY OF MECH. SEALS IN THE EVENT THE FACES HAVE LOCKED.

FAULT FINDING IN THE UNIT.

TROUBLE GUIDE	CAUSE	REMEDY
<u>PUMP DOES NOT START.</u>	1.FUSES BLOWN. 2.CABLE DAMAGED 3.NO POWER. 4.BLOCKED IMPELLER. 6.STATOR WINDING BURNT.	1.REPLACE FUSES 2.SHORTEN/REPLACE CABLE 3.CHECK POWER SUPPLY. 4.CLEAN BOTTOM PARTS. 6.REPLACE STATOR/REWIND
3.CHECK & RECONNECT.	1.BLOCKED IMPELLER. 2.PUMP STARTS BUT STOPS 3.VOLTAGE LOW/HIGH 4.CLOGGED STRAINER 5.PUMP RUNNING DRY 6.WATER TOO WARM (ABOVE 60 DEGREES C)	1.CLEAN BOTTOM PARTS. 2.CONNECTED FOR WRONG VOLTAGE 3.CONTACT POWER CO. 4.CLEAN STRAINER 5.SWITCH OFF POWER 6.SWITCH OFF POWER
<u>PUMP GIVES TOO LITTLE OUTPUT</u>	1.PUMP WORN DOWN. 2.LONG HOSE AND DIAMETER TOO SMALL. 3.PRESSURE HEAD TOO HIGH 4.DISCHARGE HOSE TORN 5.LEAKING/CRACKED OUTLET	1.REPLACE WEAR PARTS 2.CHECK PRESSURE LOSSES 3.USE PUMPS IN TANDEM. 4.USE NEW HOSE 5.REPL.OUTLET/GASKET.

TECHNICAL DESCRIPTION.

THE MODY SUBMERSIBLE PUMP IS IN ITSELF A COMPLETE PUMPING STATION. BESIDES A POWER SUPPLY AND A DISCHARGE HOSE NO EXTRA EQUIPMENT IS REQUIRED. THE COMPLETE PUMPSET IS IN A MODULAR CONSTRUCTION ENSURING GOOD AND SIMPLE SERVICEABILITY. THE MAJOR DESIGN FEATURES ARE AS UNDER:

THE MOTOR

A RUGGED ALUMINUM DIE CAST/COPPER ROTOR DYNAMICALLY BALANCED TO GRADE 2.5 ACCURACY OF ISO 942.A STAINLESS STEEL SHAFT RUNNING IN TWO BALL BEARINGS. INSULATION CLASS "5" (155 DEGREES CELSIUS). END WINDINGS DULY EPOXY COATED TO PREVENT DETERIORATION OF INSULATION EVEN IN EXTREMELY HUMID CONDITIONS. WINDING WIRE IS DUAL COATED SUITABLE FOR "F" CLASS INSULATION.

THE SEAL CHAMBER

THE HEART OF THE MODO PUMP. DOUBLE MECHANICAL, SILICON CARBIDE V/S SILICON CARBIDE SEAL FACES (LOWER SEAL) AND TUNGSTEN CARBON V/S CERAMIC (UPPER SEAL), SECONDARY SEALS OF HNBR RUBBER AND METAL PARTS IN STAINLESS STEEL, RUNNING IN AN OIL BATH, WITH AN EXTERNAL LIP SEAL - CREATES THE ULTIMATE SEAL SOLUTION. THE DESIGN OPTIMIZES SEAL LIFE AND ALLOWS FOR SIX MONTHLY (2500 HOURS) SERVICE INTERVALS.

BEARINGS.

SINGLE ROW DEEP GROOVE BALL BEARINGS SEALED FOR LIFE WITH A SPECIAL HIGH TEMPERATURE BEARING GREASE REQUIRING NO PERIODIC MAINTENANCE WHATSOEVER.

THE HYDRAULIC ELEMENTS.

THE STAINLESS STEEL IMPELLER RUNNING AGAINST A CAST IRON SUCTION COVER AND WEAR PLATE, CONSTITUTE THE HYDRAULIC ELEMENTS OF THE PUMP. THE IMPELLER CAN BE ADJUSTED TO MAINTAIN MAXIMUM OUTPUT AFTER USAGE WITHOUT PARTS REPLACEMENT. IT IS IMPORTANT, HOWEVER, TO MAINTAIN CLEARANCES BETWEEN THE WEAR PARTS.

CABLE GLAND ASSEMBLY. (REFER DRG.)

THE PUMP IS SUPPLIED WITH 20 FEET CABLE AS STANDARD. THE CABLE IS A 3 CORE EPR SHEATHED AND INSULATED CABLE CONFORMING TO INTERNATIONAL STANDARDS. THE CABLE IS WATERPROOF AND CAN BE COMPLETELY SUBMERGED IN WATER. THE CABLE IS TERMINATED IN THE PUMP AT THE CABLE GLAND. THE GLAND ASSEMBLY SEALS THE CABLE ON THE OUTSIDE SHEATH. THE CABLE IS ALSO ANCHORED TO THE BODY OF THE PUMP USING A SHACKLE - THIS IS ESSENTIAL TO ENSURE THAT THERE IS NO UNDUE STRAIN ON THE CABLE IF THE PUMP IS PULLED OR LOWERED INADVERTENTLY BY MEANS OF THE CABLE. COMPLETE DETAILS OF THE CABLE GLAND ASSEMBLY ARE SHOWN IN THE DRAWING.

NON REPAIRABLE ITEMS

1. ALL "O" RINGS TO BE REPLACED WHENEVER PARTS ARE DISMANTLED.
2. SEAL ELASTOMER PARTS SHOULD NEVER BE RE-USED AFTER DIS-ASSEMBLY.
3. DO NOT REFILL BEARING GREASE. ALWAYS REPLACE COMPLETE NEW BEARING WITH SPECIAL HIGH TEMPERATURE GREASE.

ELECTRICAL INFORMATION.

MOTORS ARE DESIGNED TO OPERATE ON SINGLE VOLTAGE AND FREQUENCY. MAX. DEVIATION IN VOLTAGE ALLOWED IS + - 6 % AND FREQUENCY +- 3%. CHECK NAME PLATE FOR OPERATING VOLTAGE AND FREQUENCY.

OIL SPECIFICATIONS

- A) H.P. ENKLO OIL 46/48
- B) SHELL TELLUS 29.
- C) CHEVRON SUPERLA FDA APPROVED WHITE # 10

USE NON-CONDUCTING, NON-FOAMING, NON-DETERGENT OIL ONLY

Index	Description	Material
1	Cable	
2	Handle	SC
3	Discharge head	FC 20
4	Flange	FC 20
5	Capacitor	
6	Motor cover	SUS-304
7	Thermal protector	
8	Switch plate	Allu.
9	Bearing	
10	Outer case	SUS-304
11	Motor frame	SUS-304
12	Stator	
13	Shaft/Rotor without Bearing	SUS-410
14	Bearing bracket	FC-20
15	Mech.seal	
16	Seal bracket	FC-20
17	Oil seal	SUS-304
18	Inlet plate	FC-20
19	Impeller	FC-20
20	Strainer	SUS-304

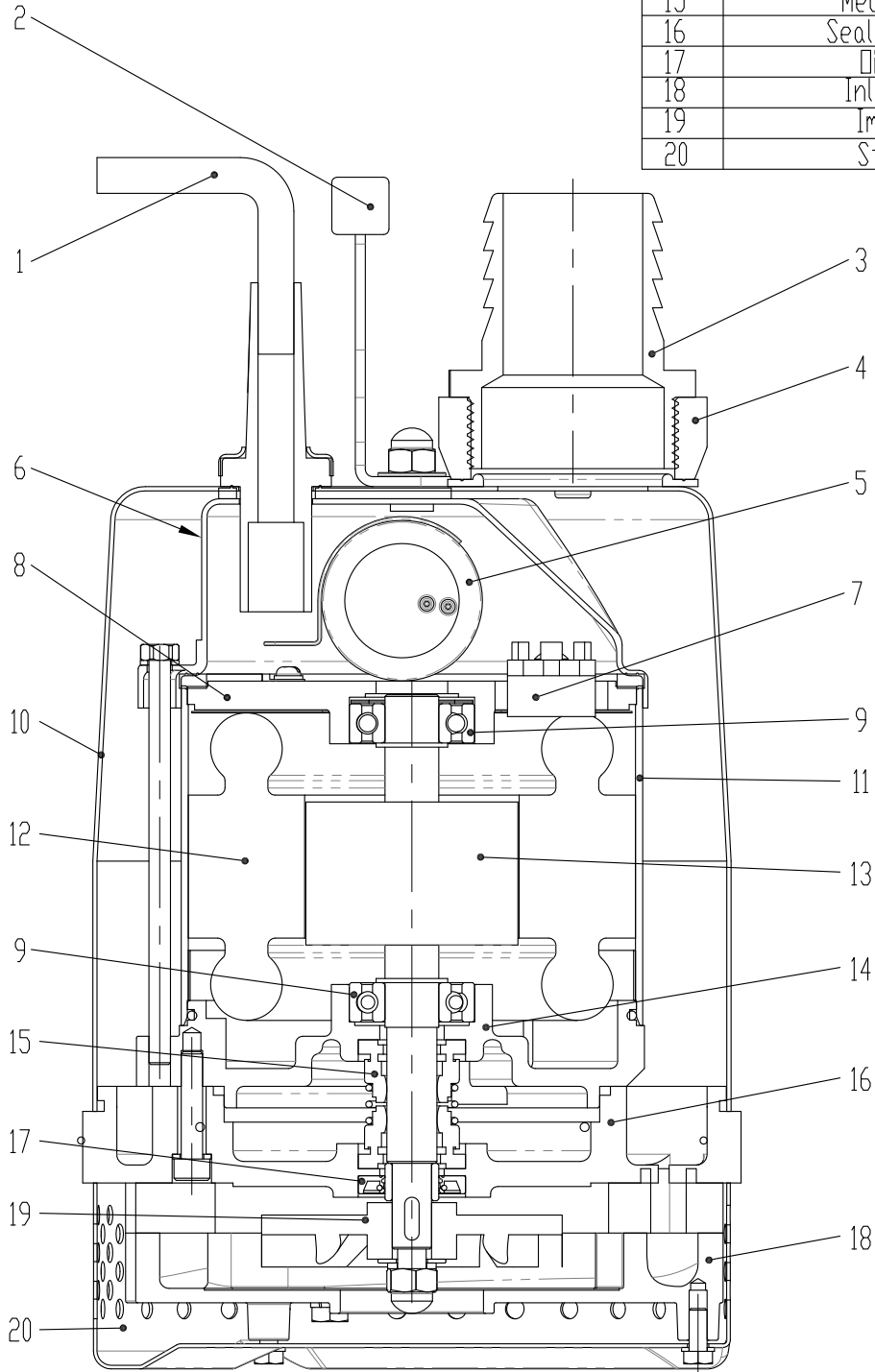

MODY M-0.5

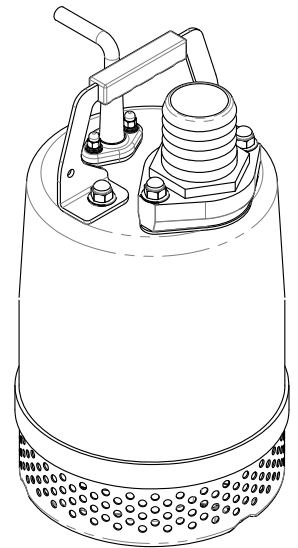
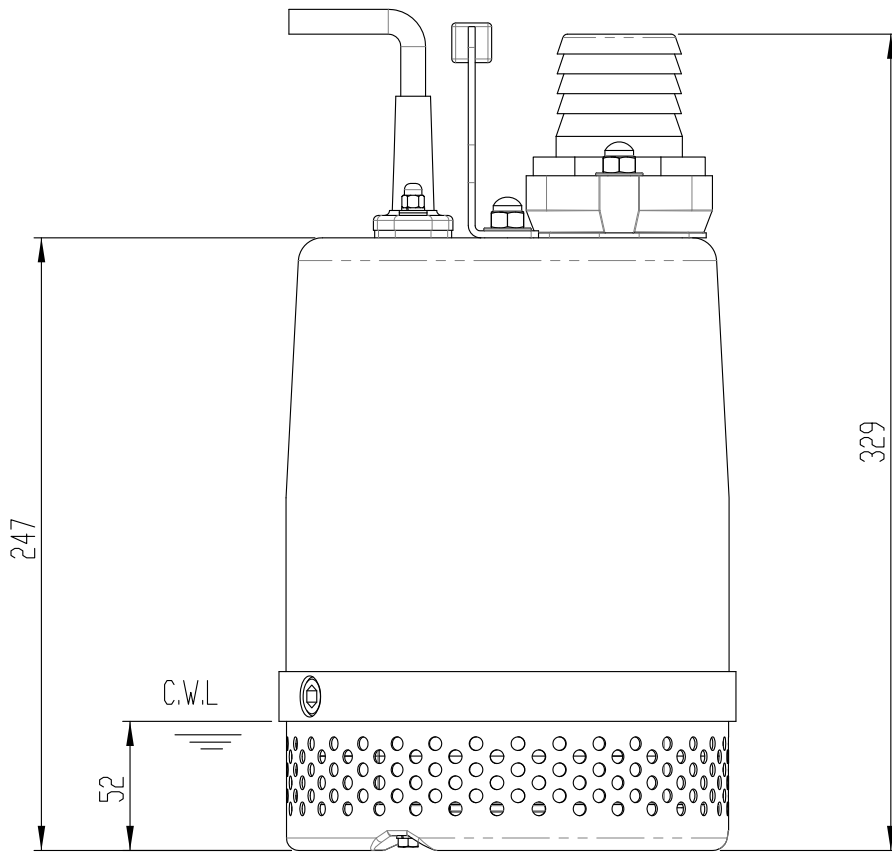
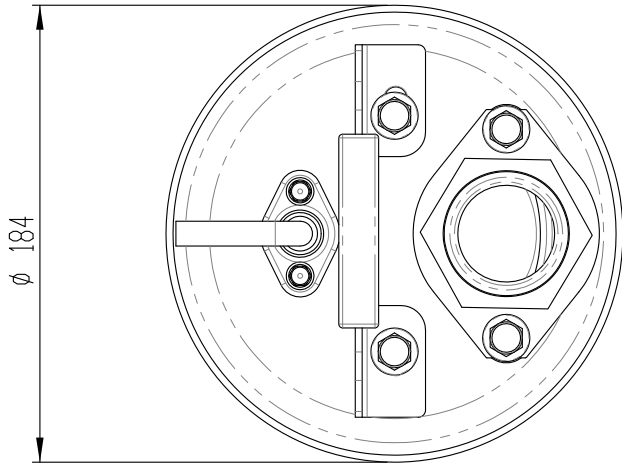

Units :mm

MODY M-0.5

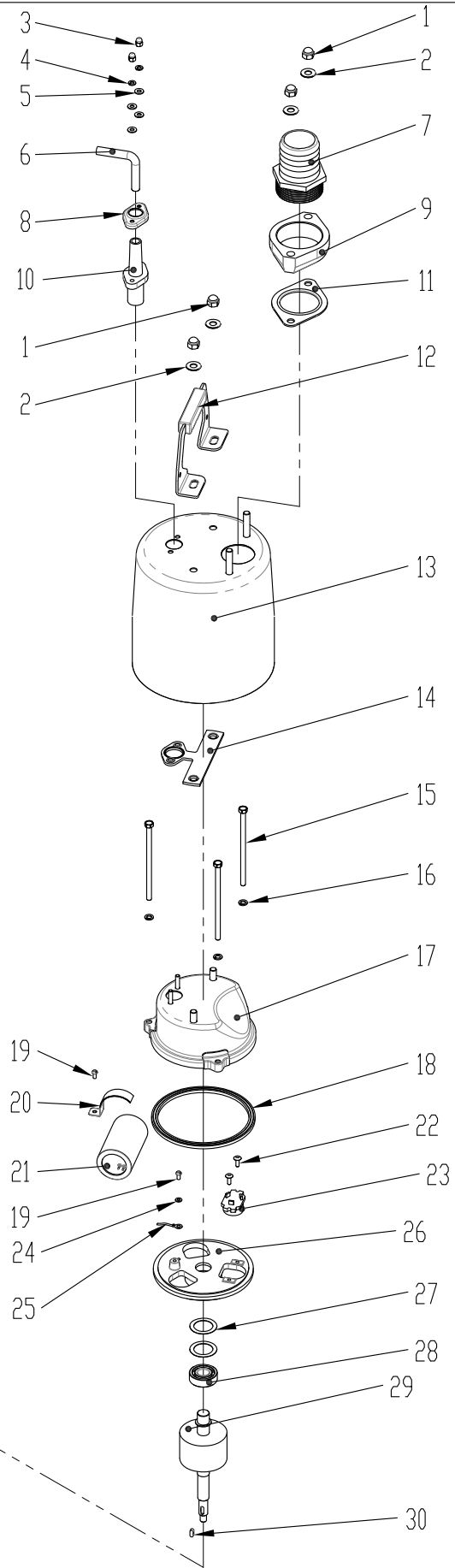
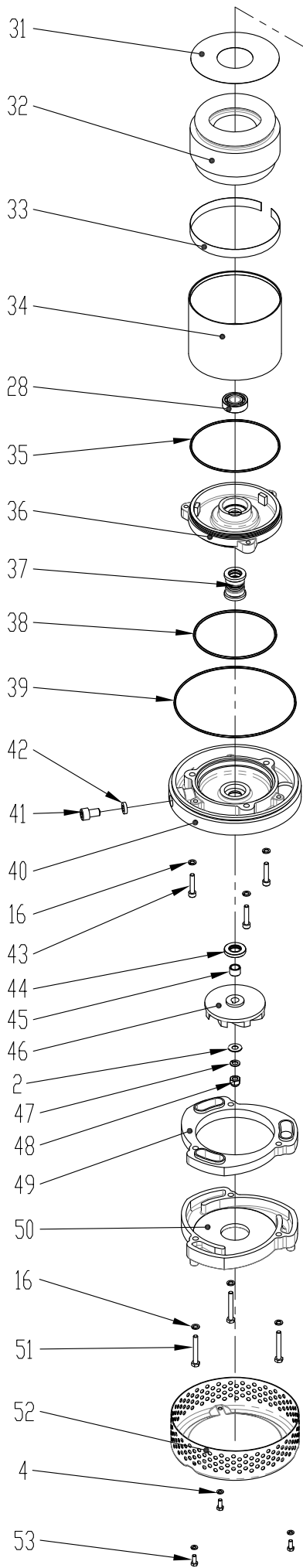

MODY M-0.5

BOM

MODY M-0.5

60HZ

REV : A

Index	Code No	Description	Qty	Size	Material
1	7424308	Nut	4	M8	SUS-304
2	752430008-01	Washer	5	M8*19*1.1T	SUS-304
3	7424305	Nut	2	M5	SUS-304
4	753430005-01	Spring washer	5	M5 · 3/16"	SUS-304
5	752430005	Washer	4	M5.1*11.17*1T	SUS-304
6	8104163070311	Cable	1	SJTW · 16AWG*3C*6.4M	
7	01360632-1	Discharge head	1	2" NPT	FC-20
8	68431	Gland Holder	1		SUS-304
9	1401061	Flange	1	2"	FC-20
10	66715080	Cable gland	1	8MM	NBR
11	455FS007510	Gasket	1		N-70
12	02304	Handle	1		SC
13	1843FS0040	Outer case	1		SUS-304
14	451FS007510	Gasket	1		N-70
15	73436061131	Screw	3	Flat hex.M6*113	SUS-304
16	753430006-01	Spring washer	9	M6 · 1/4"	SUS-304
17	0443FS0075	Motor cover	1		SUS-304
18	452FS015010	Gasket	1		N-70
19	73303040081	Screw	2	Round cross M4*8	SC
20	65312	Shim	1	57mm	SC
21	721250040	Capacitor	1	250V*40UF	
22	73433040121	Screw	2	CrossM4*12	SUS-304
23	7127-05	Thermal protector	1	MGP-38-AGU-806	
24	757300004	Washer	1	4MM	SC
25	811803	Earth lead	1	16AWG*20cm	
26	0350FS0075	Switch plate	1		Allu.
27	751306202	Wave washer	2	BWW-6202	SC
28	79362021	Bearing	2	ZZ*6202	
29	321FS0040	Shaft/Rotor without Bearing	1	166*40*15	SUS-410
30	772431-01	Key	1	4*4*10	SUS-304
31	64901123A	Insulating sheet	1	123MM*50	
32	311110204E3-B	Stator	1	25*60*40L	
33	6531114	Shim	1	14MM	SC
34	1743125095	Motor frame	1	125*95H	SUS-304
35	411026-01	O'ring	1	2.62MM*120.3	N-70
36	1936FS0040	Bearing bracket	1		FC-20
37	432214	Mech.seal	1	Double-ED*560*M14	
38	411031-01	O'ring	1	3.1MM*104.4	N-70
39	411026-03	O'ring	1	2.62MM*165	N-70
40	1136FS0075	Seal bracket	1		FC-20
41	73432100161	Screw	1	Socket hex.M10*16	SUS-304
42	459010	Gasket	1		N-70
43	73432060301	Screw	3	Socket hex.M6*30	SUS-304
44	4214316-02	Oil seal	1	16MM-30*5	SUS-304
45	674315-01	Shaft sleeve	1	15MM*11*10.5H	SUS-304
46	1536FS0040084	Impeller	1	84*11	FC-20
47	753430008-01	Spring washer	1	M8 · 5/16"	SUS-304
48	7434308	Nut	1	M8	SUS-304
49	454FLS004010	Gasket	1		N-90
50	1236FS0075	Inlet plate	1		FC-20
51	73431060451	Screw	3	Flat hex.M6*45	SUS-304
52	13435505007	Strainer	1	5.5MM*50*176	SUS-304
53	73431050121	Screw	3	Flat hex.M5*12	SUS-304

Index	Description	Material
1	Handle	SC
2	Cable	
3	Discharge head	FC-20
4	Flange	FC-20
5	Motor cover	SUS-304
6	Capacitor	
7	Thermal protector	
8	Switch plate	FC-20
9	Bearing	
10	Outer case	SUS-304
11	Motor frame	SUS-304
12	Stator	
13	Shaft/Rotor without Bearing	SUS-410
14	Bearing	
15	Bearing bracket	FC-20
16	Seal bracket	FC-20
17	Mech.seal	
18	Oil seal	SUS-304
19	Impeller	FC-20
20	Inlet plate	FC-20
21	Strainer	SUS-304

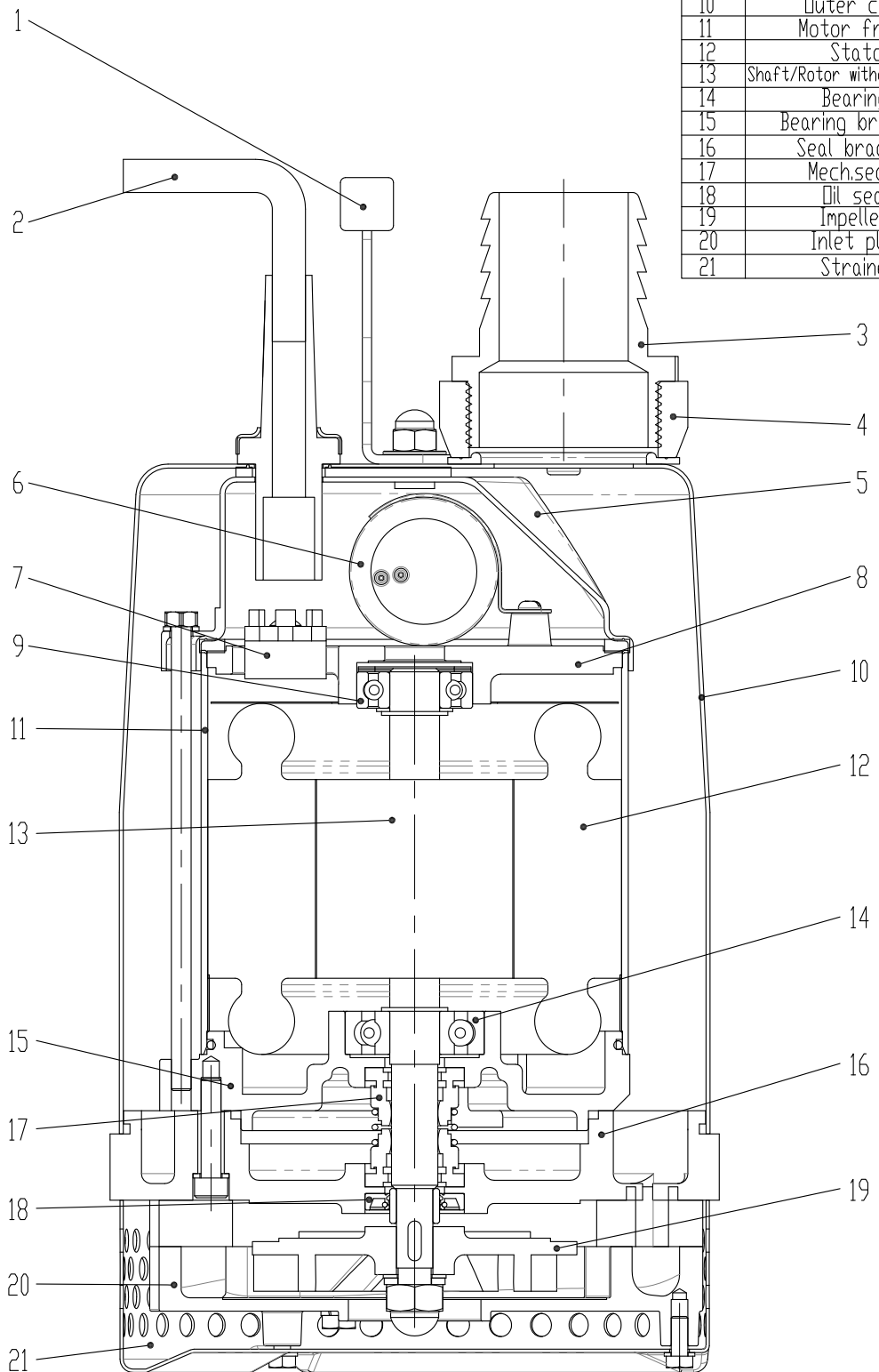

MODY M-1

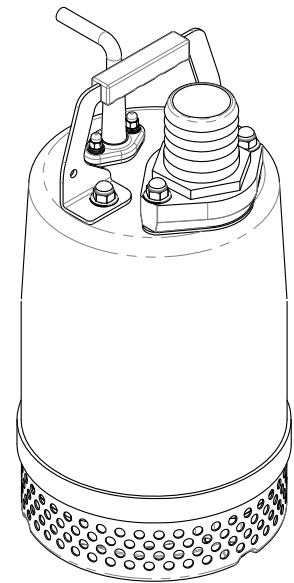
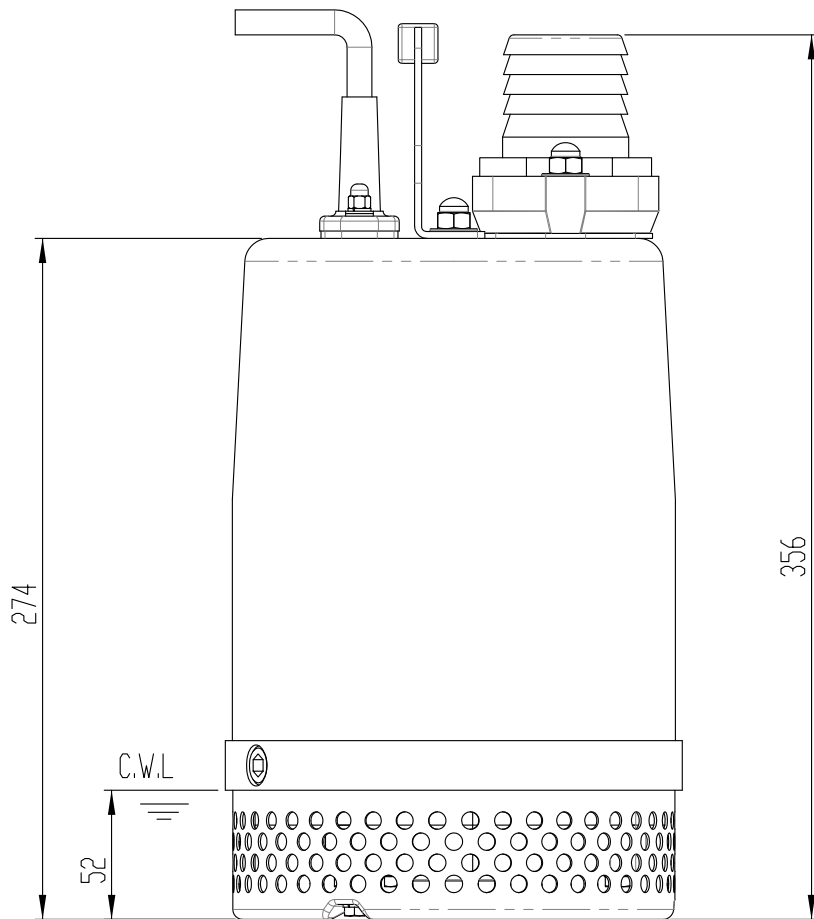
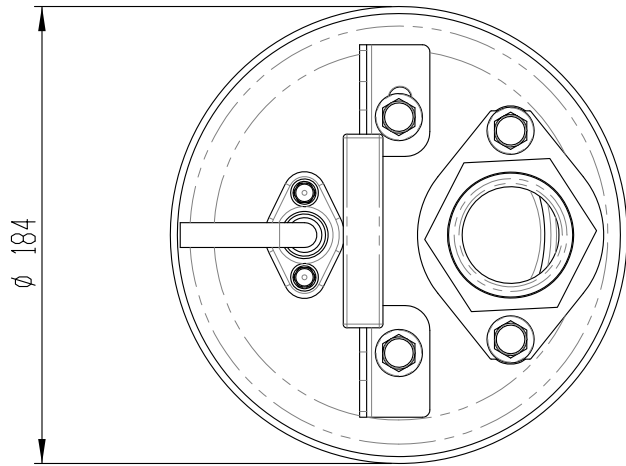

MODY M-1

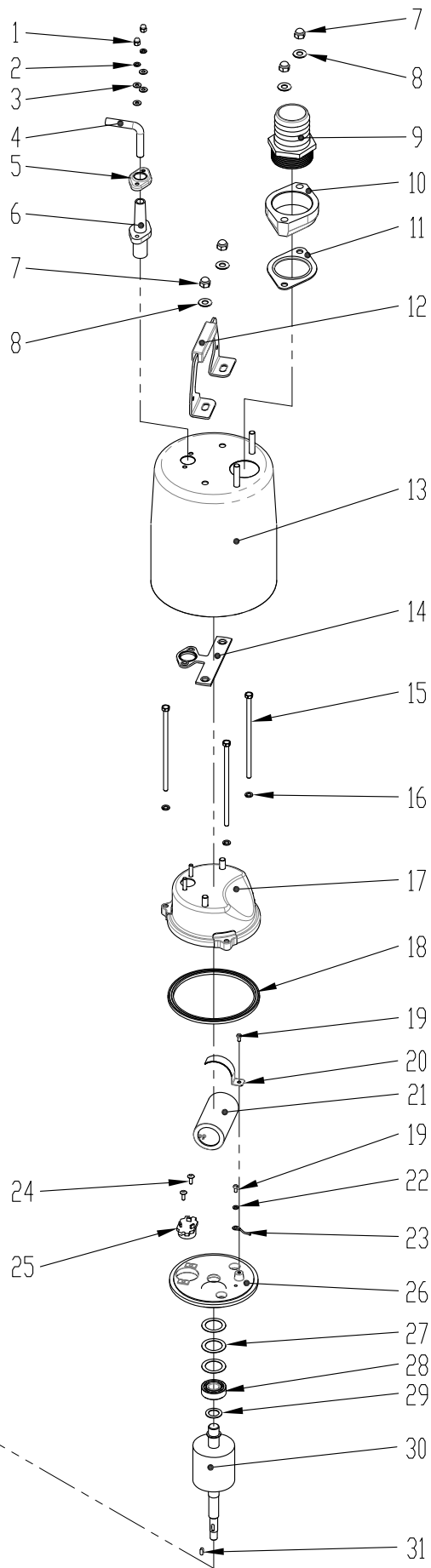
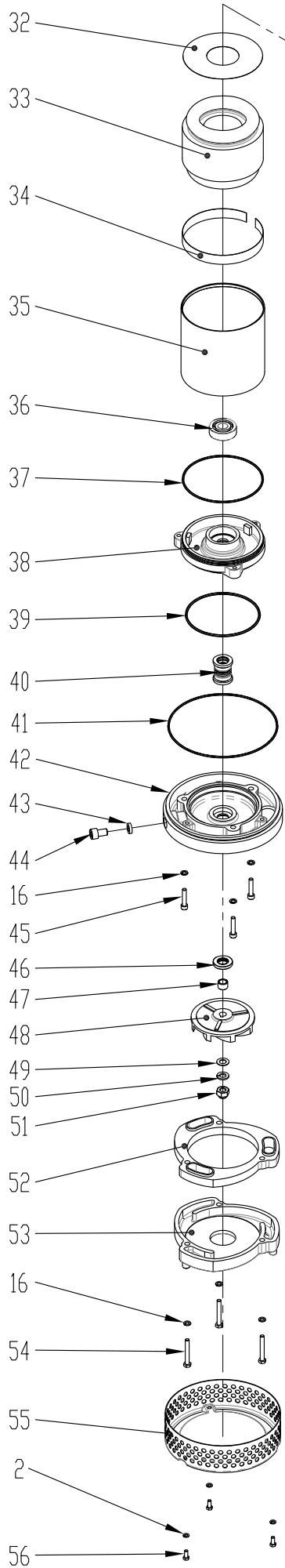

MODY M-1

BOM

MODY M-1

60HZ

REV : A

Index	Code No	Description	Q'ty	Size	Material
1	7424305	Nut	2	M5	SUS-304
2	753430005-01	Spring washer	5	M5 · 3/16"	SUS-304
3	752430005	Washer	4	M5.1*11.17*1T	SUS-304
4	8104143070311	Cable	1	SJTW · 14AWG*3C*6.4M	
5	68431	Gland Holder	1		SUS-304
6	66715085	Cable gland	1	8.5MM	NBR
7	7424308	Nut	4	M8	SUS-304
8	752430008-01	Washer	4	M8*19*1.1T	SUS-304
9	01360632-1	Discharge head	1	2" NPT	FC-20
10	1401061	Flange	1	2"	FC-20
11	455FS007510	Gasket	1		N-70
12	02304	Handle	1		SC
13	1843FS0075	Outer case	1		SUS-304
14	451FS007510	Gasket	1		N-70
15	73436061401	Screw	3	Flat hex.M6*140	SUS-304
16	753430006-01	Spring washer	9	M6 · 1/4"	SUS-304
17	0443FS0075	Motor cover	1		SUS-304
18	452FS015010	Gasket	1		N-70
19	73303040081	Screw	2	Round cross M4*8	SC
20	65312	Shim	1	57mm	SC
21	721250050	Capacitor	1	250V*50UF	
22	757300004	Washer	1	4MM	SC
23	811802	Earth lead	1	14AWG*20cm	
24	73433040121	Screw	2	CrossM4*12	SUS-304
25	7127-06	Thermal protector	1	MGA-1002-806	
26	0336FS0075	Switch plate	1		FC-20
27	751306202	Wave washer	3	BWW-6202	SC
28	79362021	Bearing	1	ZZ*6202	
29	752306202-02	Washer	1	15*23*1T	SC
30	321FS0075	Shaft/Rotor without Bearing	1	195*60*15	SUS-410
31	772431-01	Key	1	4*4*10	SUS-304
32	64901123A	Insulating sheet	1	123MM*50	
33	311110206F3-B	Stator	1	125*60*60L	
34	6531117	Shim	1	17MM	SC
35	1743125120	Motor frame	1	125*122H	SUS-304
36	79363021	Bearing	1	ZZ*6302*C3	
37	411026-01	O'ring	1	2.62MM*120.3	N-70
38	1936FS0075	Bearing bracket	1		FC-20
39	411031-01	O'ring	1	3.1MM*104.4	N-70
40	432214	Mech.seal	1	Double-ED*560*M14	
41	411026-03	O'ring	1	2.62MM*165	N-70
42	1136FS0075	Seal bracket	1		FC-20
43	459010	Gasket	1		N-70
44	73432100161	Screw	1	Socket hex.M10*16	SUS-304
45	73432060301	Screw	3	Socket hex.M6*30	SUS-304
46	4214316-02	Oil seal	1	16MM-30*5	SUS-304
47	674315-01	Shaft sleeve	1	15MM*11*10.5H	SUS-304
48	1536FS0075098	Impeller	1	98*11	FC-20
49	752430010-01	Washer	1	M10*22*1T	SUS-304
50	753430010-01	Spring washer	1	M10 · 3/8"	SUS-304
51	7434310	Nut	1	M10	SUS-304
52	454FLS004010	Gasket	1		N-90
53	1236FS0075	Inlet plate	1		FC-20
54	73431060451	Screw	3	Flat hex.M6*45	SUS-304
55	13430705007	Strainer	1	7MM*50*176	SUS-304
56	73431050121	Screw	3	Flat hex.M5*12	SUS-304

Index	Description	Material
1	Cable	
2	Handle	SUS-304
3	Discharge head	FC-20
4	Flange	FC-20
5	Motor cover	SUS-304
6	Capacitor	
7	Thermal protector	
8	Switch plate	FC-20
9	Bearing	
10	Motor frame	SUS-304
11	Outer case	SUS-304
12	Shaft/Rotor without Bearing	S410
13	Stator	
14	Bearing	
15	Bearing bracket	FC-20
16	Mech.seal	
17	Seal bracket	FC-20
18	Oil seal	SUS-304
19	Impeller	FC-20
20	Inlet plate	FC-20
21	Strainer	SUS-304

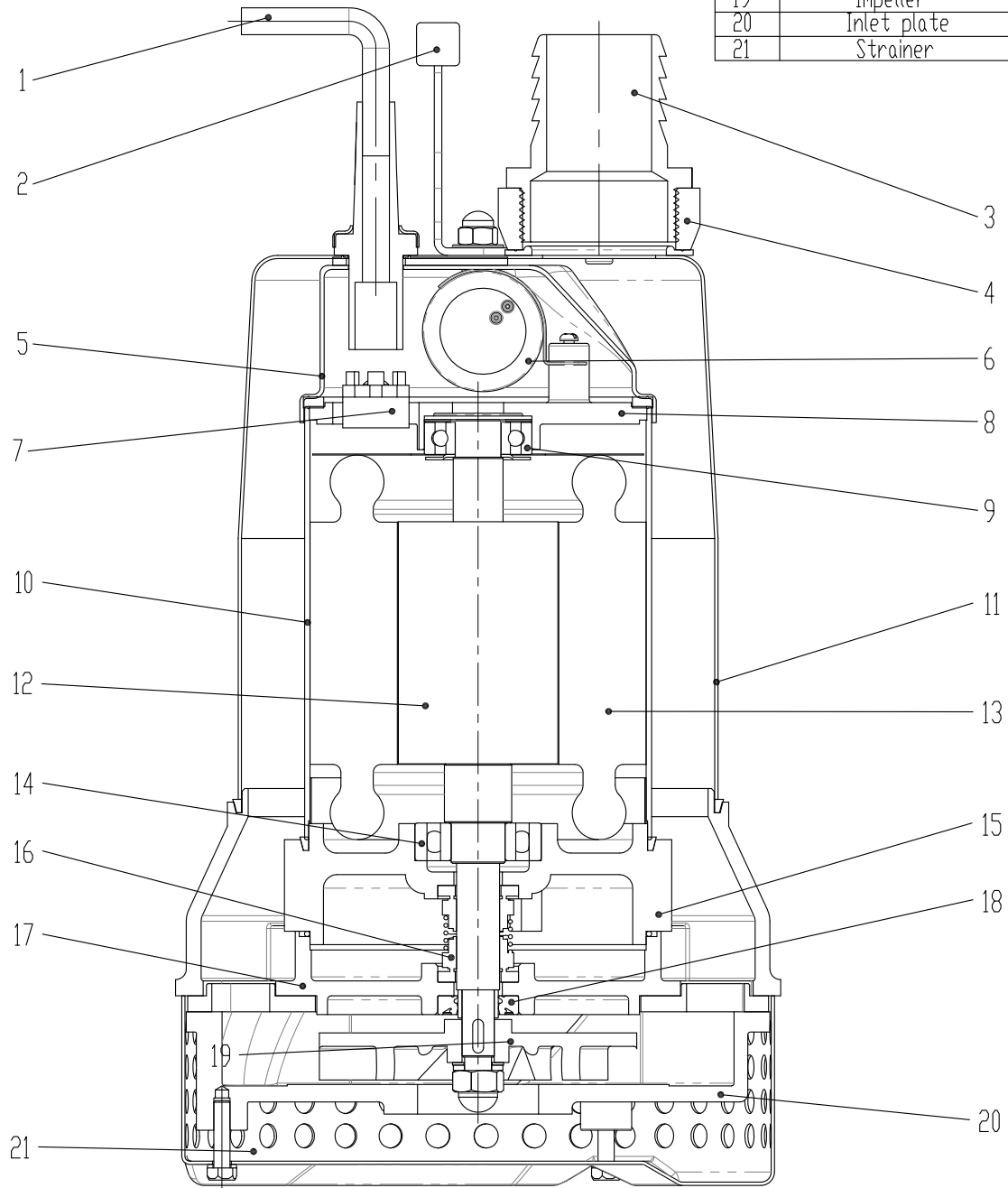

MODY M-2

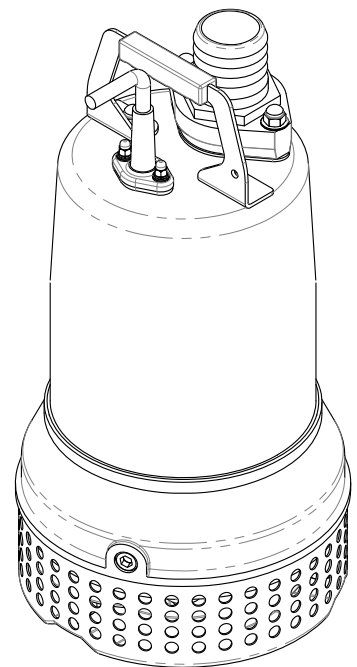
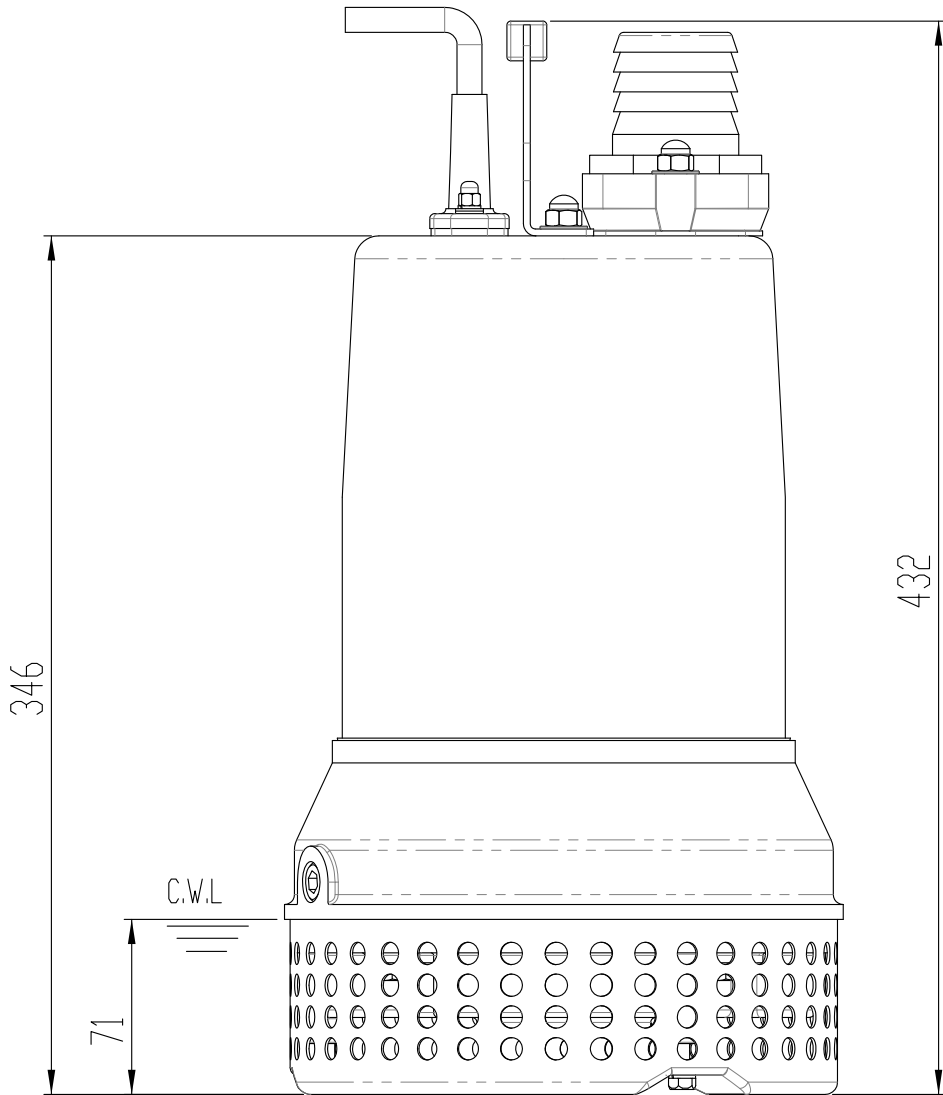
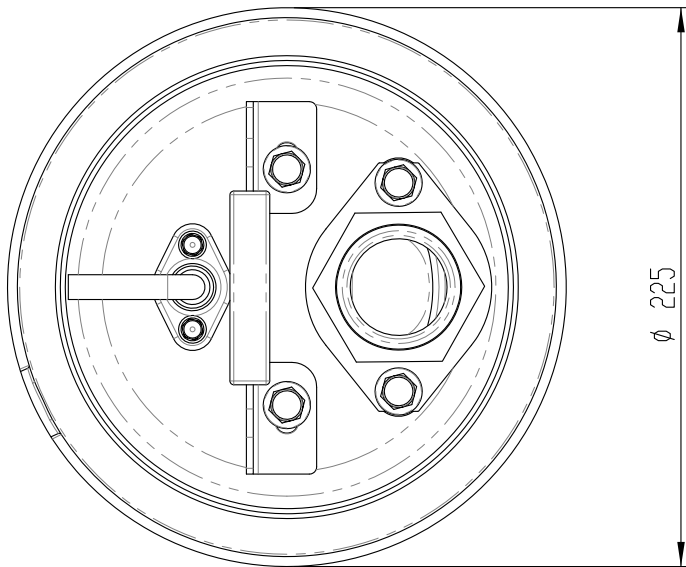

MODY M-2

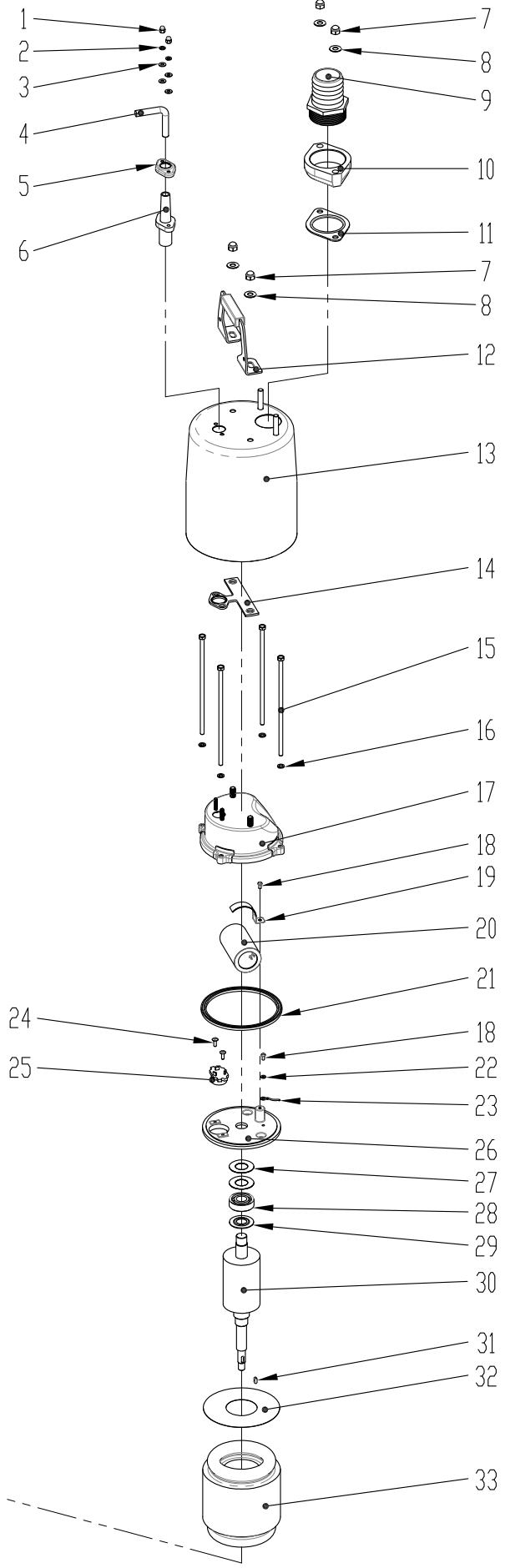
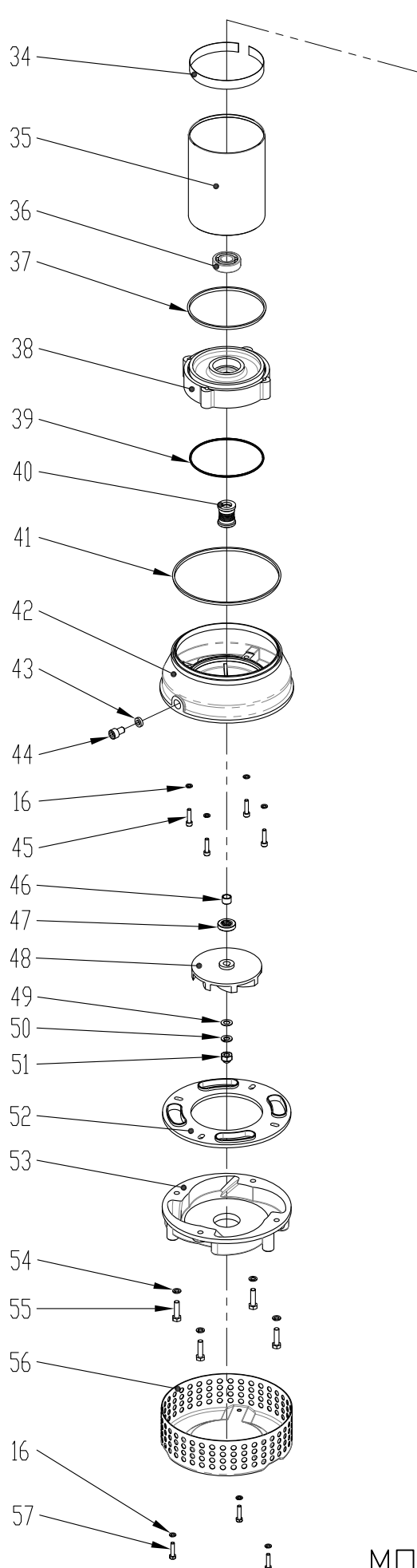

MODY M-2

BOM

MODY M-2

60HZ

REV : A

Index	Code No	Description	Q'ty	Size	Material
1	7424305	Nut	2	M5	SUS-304
2	753430005-01	Spring washer	2	M5 · 3/16"	SUS-304
3	752430005	Washer	4	M5.1*11.17*1T	SUS-304
4	8104123100111	Cable	1	SJTW · 12A*3C*10M	
5	68431	Gland Holder	1		SUS-304
6	66715120	Cable gland	1	SJTW · 12A*3C*10M	NBR
7	7424308	Nut	4	M8	SUS-304
8	752430008-01	Washer	4	M8*19*1.1T	SUS-304
9	01360632-1	Discharge head	1	2" NPT	FC-20
10	1401061	Flange	1	2"	FC-20
11	455FS007510	Gasket	1		N-70
12	02434	Handle	1		SUS-304
13	1843FS0075	Outer case	1		SUS-304
14	451FS007510	Gasket	1		N-70
15	73436061851	Screw	4	Flat hex.M6*180	SUS-304
16	753430006-01	Spring washer	11	M6 · 1/4"	SUS-304
17	0443FCS0150	Motor cover	1		SUS-304
18	73303040081	Screw	2	Round cross M4*8	SC
19	65312	Shim	1	57mm	SC
20	721400030	Capacitor	1	400V*30UF	
21	452FS015010	Gasket	1		N-70
22	757300004	Washer	1	4MM	SC
23	811202	Earth lead	1	12AWG*25cm	
24	73433040121	Screw	2	CrossM4*12	SUS-304
25	7127-04	Thermal protector	1	CCXL00 CGHOOXN	
26	0336FCS0150	Switch plate	1		FC-20
27	751306203	Wave washer	2	BWW-6203	SC
28	79362031	Bearing	1	ZZ*6203	
29	752306203-01	Washer	1	M17*39*1T	SC
30	321KO0150	Shaft/Rotor without Bearing	1	250.5*90	S410
31	772431-01	Key	1	4*4*10	SUS-304
32	64901123A	Insulating sheet	1	123MM*50	
33	311110209F3-B	Stator	1	125*60*90L	
34	6531117	Shim	1	17MM	SC
35	1743125160	Motor frame	1	125*161H	SUS-304
36	79362041	Bearing	1	ZZ*6204	
37	457FCS015010	Gasket	1		N-70
38	1936FCS0150	Bearing bracket	1		FC-20
39	411026-01	O'ring	1	2.62MM*120.3	N-70
40	432216-1	Mech.seal	1	ED*560*M16-1	
41	456FCS015010	Gasket	1		N-70
42	1136FCS0150	Seal bracket	1		FC-20
43	459010	Gasket	1		N-70
44	73432100161	Screw	1	Socket hex.M10*16	SUS-304
45	73432060251	Screw	4	Socket hex.M6*25	SUS-304
46	674315-02	Shaft sleeve	1	15MM*12*10.5H	SUS-304
47	4214316-01	Oil seal	1	16MM-30*7	SUS-304
48	1536FCS0150118	Impeller	1	118*12	FC-20
49	752430010-01	Washer	1	M10*22*1T	SUS-304
50	753430010-01	Spring washer	1	M10 · 3/8"	SUS-304
51	7434310	Nut	1	M10	SUS-304
52	454FCS015010	Gasket	1		N-80
53	1236FCS0150A	Inlet plate	1		FC-20
54	753430008-01	Spring washer	4	M8 · 5/16"	SUS-304
55	73431080301	Screw	4	Flat hex.M8*30	SUS-304
56	13431007008	Strainer	1	10MM*70*218	SUS-304
57	73431060251	Screw	3	Flat hex.M6*25	SUS-304



LIMITED WARRANTY

WARRANTY PERIOD: We warrant that our pumps, when installed and maintained in accordance with our instructions, will be free of defects in material and workmanship under normal use and service, during the following time: **One (1) year from the date of installation, or (18) months from the date of shipment, whichever occurs first**

WARRANTY CLAIM PROCEDURE: Within the above Warranty Period, we will evaluate claims under this warranty, provided that such claims are submitted in the following sequential steps:

(a) Customer submits to Mody Pumps, Inc. - via fax, e-mail attachment, or trackable mail service - a completed Warranty Evaluation Form (WEF) within five (5) days after discovery of the claimed defect;

(b) Mody Pumps, Inc. issues the Customer a **written** Return Material Authorization (RMA), via fax or e-mail, within seven (7) business days of receiving the Customer's WEF;

(c) No later than five (5) business days after the date recorded on the RMA, the subject pump must either be received at, or placed in the shipper's possession for transport to, Mody Pumps, Inc. or its Authorized Service Center. A warranty-claimed pump can only be received at Mody Pumps, Inc. or its Authorized Service Center if it is returned with a valid RMA from Mody Pumps, Inc.

VOIDING FACTORS: This warranty shall not apply when damage is caused by such factors as, but not limited to: (a) improper installation, (b) improper voltage, (c) lightning, (d) sand or other abrasive materials, (e) scale or corrosion build-up due to excessive chemical content, (f) errors in specifications, (g) errors in bills of materials, (h) any modification of the product. We will not be responsible for loss, damage, or labor and other related costs that result from interruption of service caused by defective parts. Neither will we accept charges incurred by others without our prior written approval. This warranty is void if our inspection reveals that the product was used in a manner inconsistent with normal industry practice and/or our recommendations or instructions. The Customer is responsible for communicating all vital information about the application and use of the product. **THE SOLE AND EXCLUSIVE REMEDY FOR A VALID CLAIM ON ANY AND ALL PRODUCT WARRANTIES SHALL BE PRODUCT REPLACEMENT OR REPAIR AT OUR ELECTION, FOB POINT OF MANUFACTURE OR AUTHORIZED REPAIR STATION, OF SUCH PRODUCTS AND/OR PARTS AS PROVEN DEFECTIVE.**

Any additional guarantees involving special, unusual or extraordinary performance specifications must be in writing, and such writing must be signed by an authorized representative of Mody Pumps, Inc., BEFORE the subject pump is used under such additional guarantees. Whenever user-commissioned field testing results differ from our field-conditions-adjusted lab results, our laboratory results shall control. Components or accessories that come with our pumps, but have been manufactured by others, are subject only to the original manufacturer's warranty. Recommendations for special applications, or those based on our systems analyses and evaluations, will be based on our best available experience and published or generally accepted industry standards. **SUCH RECOMMENDATIONS DO NOT CONSTITUTE A WARRANTY OF SATISFACTORY PERFORMANCE, AND NO SUCH WARRANTY IS EVER GIVEN.**

THIS WARRANTY RELATES ONLY TO OUR PRODUCT. WE WILL VIGOROUSLY DEFEND AGAINST ANY CLAIM OF OUR LIABILITY FOR DAMAGES AND COSTS THAT FLOW FROM FACTORS BEYOND OUR DIRECT AND PROXIMAL CONTROL, INFLUENCE, AND RESPONSIBILITY, INCLUDING, BUT NOT LIMITED TO, LOST PROFITS, LOST INCOME, LABOR CHARGES, OR DELAYS IN PRODUCTION. THIS WARRANTY IS EXPRESSLY IN LIEU OF ANY OTHER EXPRESS OR IMPLIED WARRANTY, INCLUDING ANY WARRANTY OF MERCHANTABILITY OR FITNESS FOR A PARTICULAR PURPOSE.

No rights extended under this warranty shall be assigned to any person, whether by operation of law or otherwise, without our prior written approval. This warranty is subject to change without notice.