

Balancing Hydronic Systems

In today's energy conscious environment, building design plays an increasingly important role in energy efficiency. Balancing the HVAC system makes sure that the occupants maintain comfort while maximizing efficiency. When designing a heating or cooling system, engineers determine how much flow is needed to satisfy the heating and cooling loads of the building. It is important that the design flow be available at all terminals to ensure comfort level. ASHRAE 90.1 states that "hydronic systems shall be proportionately balanced in a manner to first minimize throttling losses; then pump impeller shall be trimmed or pump speed shall be adjusted to meet design flow conditions."

Why a System Needs to be Balanced

In the example system below (Figure 1), the pump has a specified duty point of 900 GPM at 56 ft. The design flow rates for each zone in this example have been made equivalent to simplify the mathematics.

Figure 1:

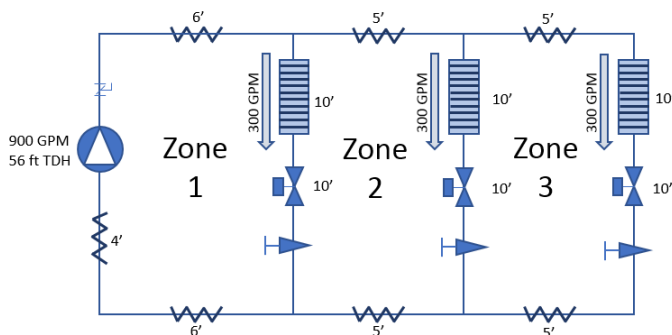

Before balancing, the flow varies by zone with the zone closest to the pump seeing the highest flow and the zone furthest away receiving the lowest. The unbalanced example system is displayed in Figure 2.

Figure 2:

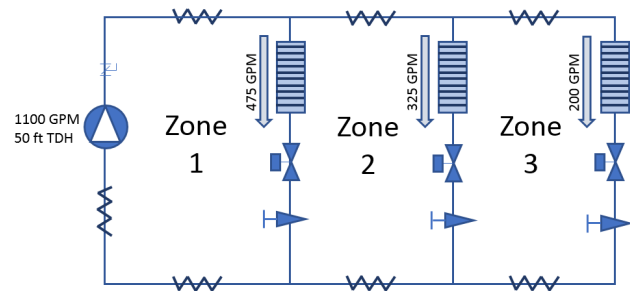

An unbalanced hydronic system will be plagued by noisy operation, high energy use, inadequate heating or cooling, and reduced valve and pump life.

In the example system, the flow rate in Zone 1 is 58% higher than design. This could cause damage to the components and noisy operation. The high velocities in the over-supplied zones can lead to control valve cavitation. Furthermore, Zone 1 sees 58% more flow than design, but that does not result in the zone heating or cooling 58% faster. It will increase energy consumption.

Zone 3's flow rate is 33% lower than design leading to an extended heating or cooling time. Zone 3 will receive an increase in flow rate after Zones 1 and 2 reach their set points.

The pump in the example system was selected to operate at 900 GPM at 56ft, but it is actually operating at 1100 GPM at 50ft. This forces the pump to operate further to the right on its curve. Depending on the pump selection, this could result in the pump operating outside of its preferable or allowable operating region. As the operating point of the pump moves further to the right of BEP, horsepower requirements and energy costs increase. Shortened bearing and seal life can occur, and higher Net Positive Suction Head Required can lead to cavitation issues.

Illinois Location:

(847) 841-7867
1675 Todd Farm Dr.
Elgin, IL 60123



PUMP SUPPLY
INCORPORATED

Minnesota Location:

(651) 758-7867
330 Mill Bay South Suite 1511
Afton, MN 55001

Proportional Balance

In a balanced hydronic system, each zone and unit in the zone has the proper flow to satisfy the designed heating and cooling loads. Balancing valves such as circuit setters are used to achieve this. To proportionally balance the example system, the pump is run at full speed and all valves are opened. The flow in the critical zone, typically the one furthest from the pump, is measured and often will be found to be less than design for peak load. In this example, design flow through Zone 3 is 300 GPM, but the actual flow is 200 GPM. The design flow in Zone 1 is 300 GPM, but the actual flow is 475 GPM. Using a balancing valve, the resistance through Zone 1 is increased so that more flow is diverted into Zone 2 and Zone 3. The balancing valve is then adjusted in Zone 2 so that additional flow is diverted to Zone 1. Since the design flow through each zone is equal, the objective is for each zone to receive one third of the total flow, thus making the system proportionally balanced. If the system is proportionally balanced and an excess of flow remains, an impeller trim or variable speed drive can be used to adjust the pump speed and further reduce energy costs (Figure 3).

Figure 3:

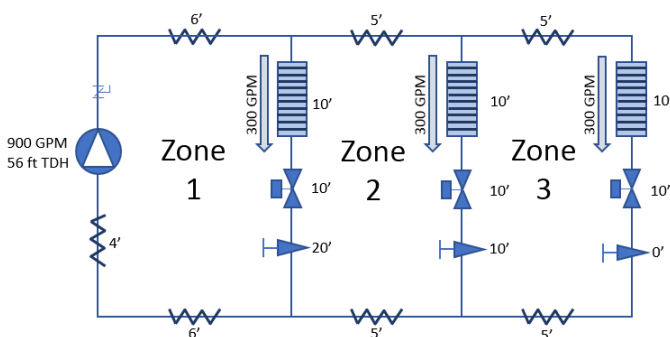

Diversity

While a system can be proportionally balanced for a given load condition, diversity can still cause issues after balancing.

Illinois Location:
 (847) 841-7867
 1675 Todd Farm Dr.
 Elgin, IL 60123



Minnesota Location:
 (651) 758-7867
 330 Mill Bay South Suite 1511
 Afton, MN 55001

Even after a system is manually balanced, it is only balanced at full flow position. Varying load requirements such as the sun rising and setting on eastern and western facing zones or zones that only require occasional heating or cooling introduce diversity into the system. When any valve in the system is changed to accommodate this diversity, the pressure in the system changes and can cause unbalance.

In addition to manual or calibrated balancing valves like circuit setters, flow limiting valves or pressure independent control valves can be utilized. A pressure independent control valve is an automatic control valve and an automatic flow regulating valve packaged in one valve body. Systems with pressure independent control valves (Figure 4) do not need to be balanced and rebalanced during commissioning. They regulate and maintain a constant flow to the coil as water pressure in the system varies with the changing loads.

Figure 4:



Whichever type of balancing valve is used, it is important that the hydronic system is balanced and that the impeller is trimmed or pump speed is adjusted so the system operates as designed without excess noise, maintenance wear, or energy use, while heating and cooling efficiently.

References

Balancing HVAC Hydronic Systems Part 1: Flow Tolerance. (2018, August 02). Retrieved June 30, 2020, from <https://www.deppmann.com/blog/monday-morning-minutes/hvac-hydronic-systems-flow-tolerance/>

Balancing HVAC Hydronic Systems Part 2: Control Valves vs. Balance Valves. (2018, August 02). Retrieved June 30, 2020, from <https://www.deppmann.com/blog/monday-morning-minutes/hvac-hydronic-systems-control-valve-balance/>

Balancing HVAC Hydronic Systems Part 3: Flow Measurement Valves. (2018, August 20). Retrieved June 30, 2020, from <https://www.deppmann.com/blog/monday-morning-minutes/hvac-hydronic-systems-flow-measurement-balance-valves/>

Edmondson, C. (2015, October 13). Hydronic Balancing Part 8: Read & Set Proportional Balance Method -. Retrieved June 30, 2020, from <http://jmpcoblog.com/hvac-blog/hydronic-balancing-part-8-read-set-proportional-balance-method>

Hardee, R. (2016, August 02). Optimizing Large Cooling Water Systems, Part 1. Retrieved June 30, 2020, from <https://www.pumpsandsystems.com/optimizing-large-cooling-water-systems-part-1>

Hardee, R. (2016, August 02). Optimizing Large Cooling Water Systems, Part 2. Retrieved June 30, 2020, from <https://www.pumpsandsystems.com/optimizing-large-cooling-water-systems-part-2>

Hays Fluid Controls. (2015, September 29). Hydronic System Balancing with ASHRAE 90.1-2013 - Hays Fluid Controls: Blog. Retrieved June 30, 2020, from <http://www.haysfluidcontrols.com/blog/hydronic-system-balancing-with-ashrae-90-1-2013/>

Holder, T. (2017, November 13). Balancing Options for Systems with Variable Speed Pump Control -. Retrieved June, 2020, from <http://jmpcoblog.com/hvac-blog/balancing-options-for-systems-with-variable-speed-pump-control>

Honeywell. (2016, April). Advantages of Pressure Independent Controls [Web log post]. Retrieved June 30, 2020, from https://buildingcontrols.honeywell.com/literature/01-00038_PR_PICV_VRN_WhitePaper.pdf

HVAC Variable Speed Pump Control System Diversity. (2018, July 05). Retrieved June 30, 2020, from <https://www.deppmann.com/blog/monday-morning-minutes/hvac-variable-speed-pump-control-system-diversity/>

Illinois Location:
(847) 841-7867
1675 Todd Farm Dr.
Elgin, IL 60123



Minnesota Location:
(651) 758-7867
330 Mill Bay South Suite 1511
Afton, MN 55001