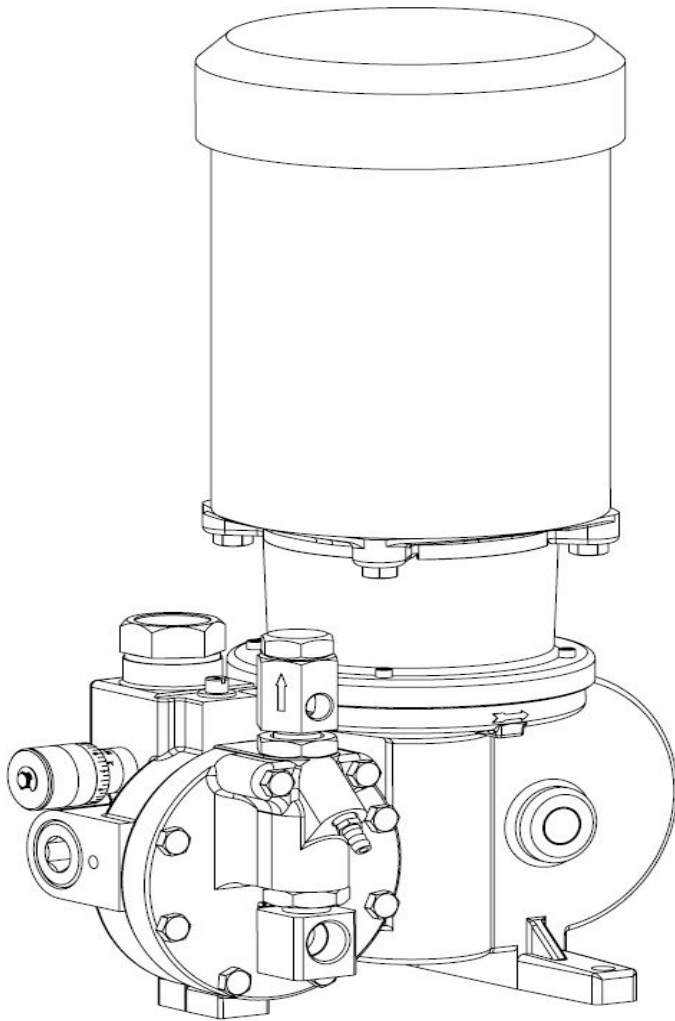




MILTON ROY®



mROY® A & B

Metering Pump IOM Manual

Manual No : 54649

Rev. : 08

Rev. Date : 01/2026



MILTON ROY®

GENERAL PRECAUTIONS FOR ALL PUMPS

The following precautions should be taken when working with metering pumps. Please read this section carefully prior to installation.

Protective Clothing



ALWAYS wear protective clothing, face shield, safety glasses and gloves when working on or near your metering pump. Additional precautions should be taken depending on the solution being pumped. Refer to **Material Safety Data Sheets** for the solution being pumped.

Hearing Protection



It is recommended that hearing protection be used if the pump is in an environment where the timeweighted average sound level (TWA) of 85 decibels is exceeded. (as measured on the A scale slow response).

Electrical Safety



- Remove power and ensure that it remains off while maintaining pump.
- **DO NOT FORGET TO CONNECT THE PUMP TO EARTH.**
- Electric protection of the motor (Thermal protection or by means of fuses) is to correspond to the rated current indicated on the motor data plate.

Liquid Compatibility



Verify if the materials of construction of the wetted components of your pump are recommended for the solution (chemical) to be pumped.

Pumps Water “Primed”



All pumps are tested with water at the factory. If your process solution is not compatible with water, flush the **Pump Head Assembly** with an appropriate solution before introducing the process solution.

Plumbing and Electrical Connections



Always adhere to your local plumbing and electrical codes.

Line Depressurization



To reduce the risk of chemical contact during disassembly or maintenance, the suction and discharge lines should be depressurized before servicing.

Over Pressure Protection



To ensure safe operation of the system, it is recommended that some type of safety / pressure relief valve be installed to protect the piping and other system components from damage due to over-pressure.

Lifting



This manual should be used as a guide only - Follow your company's recommended lifting procedures. It is not intended to replace or take precedence over recommendations, policies and procedures judged as safer due to the local environment than what is contained herein. Use lifting equipment that is rated for the weight of the equipment to be lifted.

The personnel responsible for installing, operating and maintaining this equipment must become acquainted with, assimilate and comply with the contents of this manual in order to:

- **Avoid any possible risk to themselves or to third parties,**
- **Ensure the reliability of the equipment,**
- **Avoid any error or pollution due to incorrect operation.**

Any servicing on this equipment must be carried out when it is stopped. Any accidental startup must be prevented (either by locking the switch or removing the fuse on the power supply line).

A notice must be attached to the location of the switch to warn that servicing is being carried out on the equipment.

During oil changing operations, the waste oil must be collected in a suitable receptacle. Any overflow of oil which may result must be removed using a degreasing agent suitable for the operating conditions.

Soiled cleaning cloths must be stored in suitable receptacles. The oil, degreasing agent and cleaning cloths must be stored in accordance with the rules on pollution.

Switch off the power supply as soon as any fault is detected during operation, such as overheating or unusual noise.

Special care has to be taken for chemicals used in the process (acids, bases, oxidizing/reducing solutions, etc.).



TABLE OF CONTENTS

1.0 GENERAL DESCRIPTION	7
1.1 INTRODUCTION	7
1.2 GENERAL INFORMATION	7
1.3 PUMP CHARACTERISTICS	7
1.4 PUMP PERFORMANCE	7
1.5 PRINCIPLE OF OPERATION.....	7
1.6 GENERAL SPECIFICATIONS.....	9
1.7 MODEL CODE (FIGURE 3, 4 & 30)	10
1.8 RPM KITS (FIGURE 5).....	12
1.9 CAPACITY PRESSURE TABLE (FIGURE 6, 7 ,8, 9)	15
2.0 INSTALLATION	18
2.1 UNPACKING/INSPECTION	18
2.2 STORAGE	18
2.3 SAFETY PRECAUTIONS.....	19
2.4 PUMP MOUNTING & LIFTING/LOCATION	19
2.5 OUTDOOR INSTALLATIONS	19
2.6 FLANGE MOUNTED MOTORS	21
2.7 ELECTRICAL CONNECTIONS.....	21
2.8 MOTORS	21
2.9 PUMP LUBRICATION	21
2.10 PIPING.....	22
2.11 OPERATION WITH SUCTION LIFT.....	24
3.0 OPERATION	25
3.1 INITIAL START-UP.....	25
3.2 RESETTING THE RELIEF VALVE.....	26
3.3 OPERATION.....	27
4.0 MAINTENANCE	28
4.1 SPARE PARTS.....	28
4.2 RPM KIT COMPONENTS.....	28
4.3 RETURNING UNITS TO THE FACTORY	28
4.4 ROUTINE MAINTENANCE	29
4.5 SEMI ANNUAL OIL CHANGE	29
4.6 CHECK VALVE CARTRIDGES	29
4.7 DIAPHRAGM(S)	30
4.8 RELIEF VALVE POPPET	30
4.9 CORRECTIVE MAINTENANCE	30
4.9.1 CHECK VALVE CARTRIDGE REPLACEMENT	30
4.9.1.1 METALLIC LIQUID ENDS (FIGURES 16, 17, 19 & 24).....	30
4.9.1.2 MROY A PLASTIC LIQUID END, CURRENT DESIGN (FIGURE 16).....	31
4.9.1.3 MROY B PLASTIC LIQUID END (FIGURE 24).....	32
4.9.2 RELIEF VALVE POPPET REPLACEMENT (FIGURE 15).....	32

4.9.3 DIAPHRAGM REPLACEMENT (FIGURES 16-29)	32
4.9.4 MOTOR AND WORM REPLACEMENT (FIGURES 14 & 15).....	33
4.9.5 CONTROL SPOOL O-RING REPLACEMENT (FIGURE 14, 16 & 17).....	34
4.9.6 WORM GEAR REPLACEMENT (FIGURE 14).....	34
4.9.7 CONNECTING ROD AND PLUNGER REPLACEMENT (FIGURE 14)	35
4.9.8 HEAD BOLT TORQUE PATTERN (FIGURE 13).....	35
5.0 TROUBLESHOOTING GUIDE.....	36
6.0 PARTS.....	38
6.1 GENERAL.....	38
6.2 ILLUSTRATED PARTS LIST.....	38
6.3 MROY A BASIC PARTS LIST FOR DRIVE (FIGURES 14 &15).....	49
6.4 MROY A PARTS COMMON TO METALLIC LIQUID ENDS FIGURES 16 & 17).....	51
6.5 MROY A DIAPHRAGM HEAD DESIGN - 8 BOLT E & F LIQUID ENDS (FIGURE 17).....	52
6.6 MROY A DIAPHRAGM HEAD DESIGN – “H” LIQUID END (FIGURE 18).....	52
6.7 MROY A “H” (3000 PSI) SPECIFIC PARTS (FIGURE 14 & 15).....	52
6.8 MROY A DIAPHRAGM HEAD DESIGN – 8 BOLT C & D LIQUID END (FIGURE 17).....	53
6.9 MROY A HIGH VISCOSITY “V” OPTION (FIGURE 16).....	54
6.10 MROY A PLASTIC LIQUID END PARTS (C, D, E, & F) (FIGURE 16).....	54
6.11 MROY A MOTOR MOUNT PARTS (FIGURES 14 & 15).....	56
6.12 MROY A ACTUATED CAPACITY CONTROL MOUNTING (FIGURE 23).....	59
6.13 PNEUMATIC CAPACITY CONTROL (3-15 PSI DIRECT) (FIGURE 23).....	60
6.14 MROY A SIMPLEX LEAK DETECTION PARTS – C, D, E, & F (FIGURE 20 & 22).....	60
6.15 MROY A & B DIRECT ATTACH LEAK DETECTION PARTS – (C, D, H) (FIGURE 21)	63
6.16 MROY A DOUBLE DIAPHRAGM PARTS - E & F (FIGURE 22).....	63
6.17 MROY B BASIC PARTS LIST FOR DRIVE MODELS (FIGURES 14 & 15)	69
6.18 MROY B LIQUID END – L & R FIGURE 24).....	70
6.19 MROY B LIQUID END – K (FIGURE 24).....	71
6.20 MROY B “H” (3000 PSI) SPECIFIC PARTS (FIG. 27 & 28).....	71
6.21 MROY B DIAPHRAGM HEAD DESIGN – “H” LEAK DET LIQUID END (FIGURE 28)	71
6.22 MROY B PLASTIC LIQUID END PARTS – CONVERSION KIT (FIGURE 24).....	72
6.23 MROY B PLASTIC LIQUID END PARTS (FIGURE 24).....	72
6.24 MROY B MOTOR MOUNTS (FIGURES 14 & 15).....	73
6.25 MROY B ACTUATED CAPACITY CONTROL MOUNTING (FIGURE 23).....	75
6.26 MROY B SIMPLEX LEAK DETECTION PARTS- GAUGE & NEMA SWITCH (FIGURE 25)	76
6.27 MROY B DOUBLE DIAPHRAGM PARTS FOR METALLIC LIQUID END (FIGURE 26).....	76
6.28 MROY B DOUBLE DIAPHRAGM PARTS- WITH CONDUCTIVITY PROBE FOR PLASTIC LIQUID END (FIGURE 26 & 29).....	76

LIST OF ILLUSTRATIONS

FIGURE 1. PUMP OPERATION WITH BY-PASS PORT OPEN	8
FIGURE 2. PUMP OPERATION WITH BY-PASS PORT CLOSED.....	9
FIGURE 3. GLOBAL MRA/MRB MODEL CODE	10
FIGURE 4. GLOBAL MRA/MRB MODEL CODE EXTRA	11
FIGURE 5. MROY A/B ROUTINE MAINTENANCE KIT LIST, BY MODEL CODE.....	12
FIGURE 6. MROY A - METALLIC LIQUID ENDS CAPACITY / PRESSURE TABLE.....	15
FIGURE 7. MROY B - METALLIC LIQUID ENDS CAPACITY / PRESSURE TABLE.....	15
FIGURE 8. MROY A - PLASTIC LIQUID ENDS CAPACITY / PRESSURE TABLE	16
FIGURE 9. MROY B - PLASTIC LIQUID ENDS CAPACITY / PRESSURE TABLE	16
FIGURE 10. MROY PUMP (ALL MODELS) CAPACITY DERATING TABLE.....	17
FIGURE 11. MOUNTING BOLT HOLES	20
FIGURE 12. TYPICAL PIPING AND INSTRUMENTATION DIAGRAM.....	23
FIGURE 13. DIAPHRAGM HEAD BOLT TORQUE PATTERN.....	35
FIGURE 14. COMMON PARTS - MROY A & B SIDE VIEW AND API MOTOR MOUNT	39
FIGURE 15. COMMON PARTS - MROY A & B END VIEW AND MROY A CLOSE COUPLED MOTOR MOUNT	40
FIGURE 16. MROY A HIGH VISCOSITY AND PLASTIC LIQUID END	41
FIGURE 17. MROY A METALLIC LIQUID ENDS	42
FIGURE 18. MROY A PLUNGER "H" 316SS LIQUID END	43
FIGURE 19. MROY A BAR STOCK LIQUID END.....	44
FIGURE 20. MROY A DOUBLE DIAPHRAGM AND LEAK DETECTION – C & D HEADS	45
FIGURE 21. MROY A PLUNGER "H" 316SS LIQUID END DIRECT ATTACH LEAK DETECTION WITH GAUGE	46
FIGURE 22. MROY A DOUBLE DIAPHRAGM AND LEAK DETECTION – E & F HEADS	47
FIGURE 23. MROY A AND B ACTUATOR	48
FIGURE 24. MROY B METALLIC AND PLASTIC LIQUID END	64
FIGURE 25. MROY B LEAK DETECTION WITH SWITCH AND GAUGE.....	65
FIGURE 26. MROY B GAUGE ONLY	65
FIGURE 27. MROY B PLUNGER "H" 316SS LIQUID END	66
FIGURE 28. MROY B PLUNGER "H" 316SS LIQUID END DIRECT ATTACH LEAK DETECTION WITH GAUGE	67
FIGURE 29. MROY B DOUBLE DIAPHRAGM	68
FIGURE 30. MROY B PLASTIC LIQUID END	68

1.1 INTRODUCTION

The mRoy pump is a highly reliable controlled volume pump of hydraulically actuated diaphragm design. The family of MRA & MRB frame pumps are further broken down into Model Codes. For ease of discussion, this manual will refer to either the frame size as MRA and MRB rather than the specific Model Code. The product codes for the MRA & MRB are given in Figures 3 & 4. Historical Model Codes prior to 1995 found in Appendix A.

1.2 GENERAL INFORMATION

Pump capacity is adjustable while the pump is running or stopped. Capacity adjustment can be made manually or automatically by a signal from remote control instruments.

Repetitive accuracy of the metered discharge volume is maintained within a $\pm 1\%$ range at constant conditions of pressure, temperature and pump capacity adjustment setting.

The mRoy pump is a reliable, compact, controlled volume diaphragm pump for normal corrosive or toxic chemicals and light slurries with viscosities up to 200 S.S.U. (40 CPS). For higher viscosities, the mRoy "V" option available to 12,200 CPS.

A plunger, reciprocating at a fixed stroke, displaces a fixed volume of hydraulic liquid, which actuates a flexible, chemically inert PTFE diaphragm to create pumping action. Double ball check valves are used on the suction and discharge to insure consistent metering accuracy. Capacity control is established by adjusting the volume of hydraulic liquid, which bypasses the diaphragm cavity.

Metering with repetitive accuracy is possible only if the volume of the hydraulic oil in the displacement chamber is maintained constant for each stroke. This is accomplished by mechanically opening the displacement chamber to the oil reservoir for a short period at the end of every suction stroke and the beginning of each pressure stroke. During this period air or vapor is bled from the system, lost oil is replenished, and allowances are made for the expansion or

contraction of the oil due to temperature change. For more information, refer to Principle of Operation.

1.3 PUMP CHARACTERISTICS

For a general description of the mRoy pump you have purchased, compare the model number and product code printed on the pump's data plate shown in Figure 3 to the appropriate model number and product code shown in Figures 3 & 4.

1.4 PUMP PERFORMANCE

The charts in Figures 6 through 9 show the performance ranges for all mRoy A & B pumps. If appropriate, refer also to the derating table shown in Figure 10.

1.5 PRINCIPLE OF OPERATION

Pumping action is developed and controlled by four basic components as follows (Figures 1 & 2)

1. The pump plunger "A" reciprocates with a constant stroke length and displaces oil into and out of the diaphragm chamber "C".
2. The flexible diaphragm "X" is a movable partition between the plunger oil and liquid being pumped.
3. An oil bypass circuit from the diaphragm chamber "C" to the reservoir "D" through passage "E" bypass port "H" and control spool valve "F."
4. A bypass control plunger "G" which moves with and is directly coupled to the pump plunger to correlate bypass shut off at port "H" to pump plunger position.

In operation, as the pump plunger and bypass control plunger move forward as shown in Figure 1, the displaced oil is bypassed to the oil reservoir until the control plunger "G" closes the bypass port "H" as shown in Figure 2. Then the balance of the plunger displacement is imposed on the flexible diaphragm that moves and displaces the liquid being pumped through the discharge ball checks.

SECTION 1 - GENERAL DESCRIPTION

On the suction stroke, the pump plunger pulls oil out of the diaphragm cavity, which moves the flexible diaphragm and pulls liquid through the suction ball checks. When the control plunger "G" opens the bypass port "H" the balance of the plunger oil displacement can be supplied from the reservoir through the bypass passages. The discharge capacity is adjusted from 0–100% by rotating the adjustment knob that moves the control spool valve "F" so that the bypass port "H" is closed at the desired percentage of the total plunger stroke. When the control spool valve is adjusted to 100% capacity, the bypass port will be positioned so that it is opened at the very end of the suction stroke. Then on the pressure stroke, the bypass port is immediately closed so the entire plunger displacement is imposed upon the flexible diaphragm.

With the control spool valve adjusted for 50% capacity, the bypass port will be positioned so that it is opened when the plungers have completed one-half of the suction stroke. On the next pressure stroke, the oil displaced by the pump plunger will be bypassed through the open port to the reservoir for the first 50% of the stroke, before the bypass port is closed by the control plunger. The remaining 50% of the plunger displacement will then be imposed on the flexible diaphragm so that liquid is discharged for only 50% of the plunger travel. A similar analysis would apply for 0% capacity setting on the control spool valve where all the plunger oil displacement is bypassed to the reservoir.

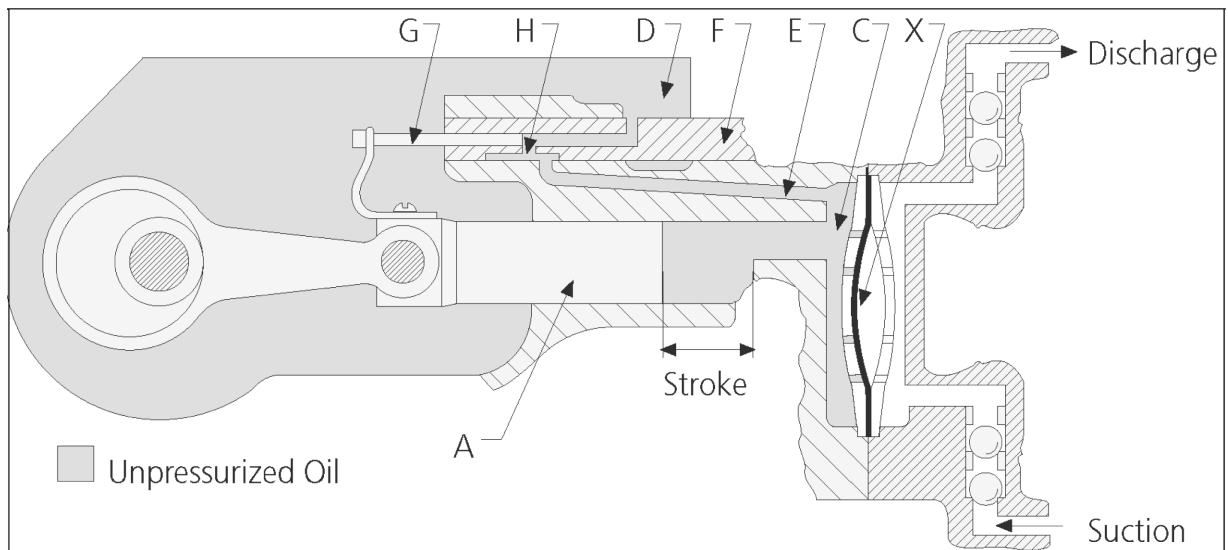


FIGURE 1. PUMP OPERATION WITH BY-PASS PORT OPEN

SECTION 1 - GENERAL DESCRIPTION

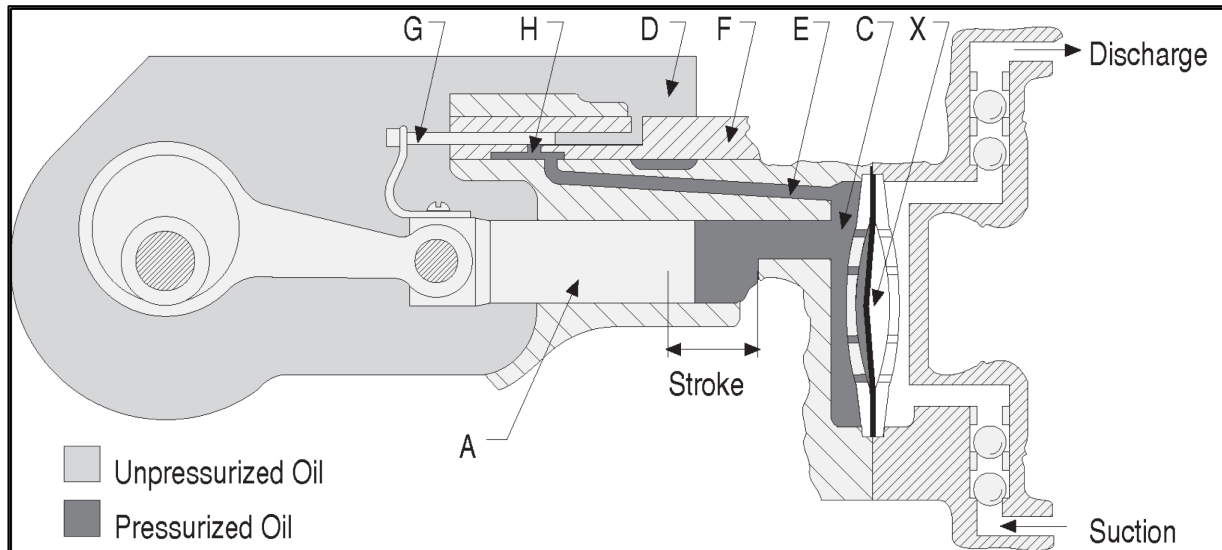


FIGURE 2. PUMP OPERATION WITH BY-PASS PORT CLOSED

1.6 GENERAL SPECIFICATIONS

Accuracy:

±1% steady state accuracy over 10:1 turndown

Drive:

Hydraulic bypass design allows adjustment from 0 to 100% of rated capacity while stopped or running

Liquid End:

High performance check valves

Diaphragm:

Hydraulically actuated Diaphragm provides 96000 hours of long life as diaphragm is hydraulically balanced in comparison with Mechanically actuated Diaphragm which is not. A diaphragm that is mechanically actuated has a life span that is directly proportional to number of strokes and differential pressure.

Relief Valve:

Adjustable internal relief valve which limits the pressure the pump can develop. Does not relieve process pressure inside the pump liquid end.

Capacity Control:

Micrometer standard

Electronic 4–20 mA

Pneumatic psi

Stroke Length:

Models mRoy A: H, C, D, E, F 0.7" (1.78 cm)

Models mRoy B: H, K, L, R 1.5" (3.81 cm)

SECTION 1 - GENERAL DESCRIPTION

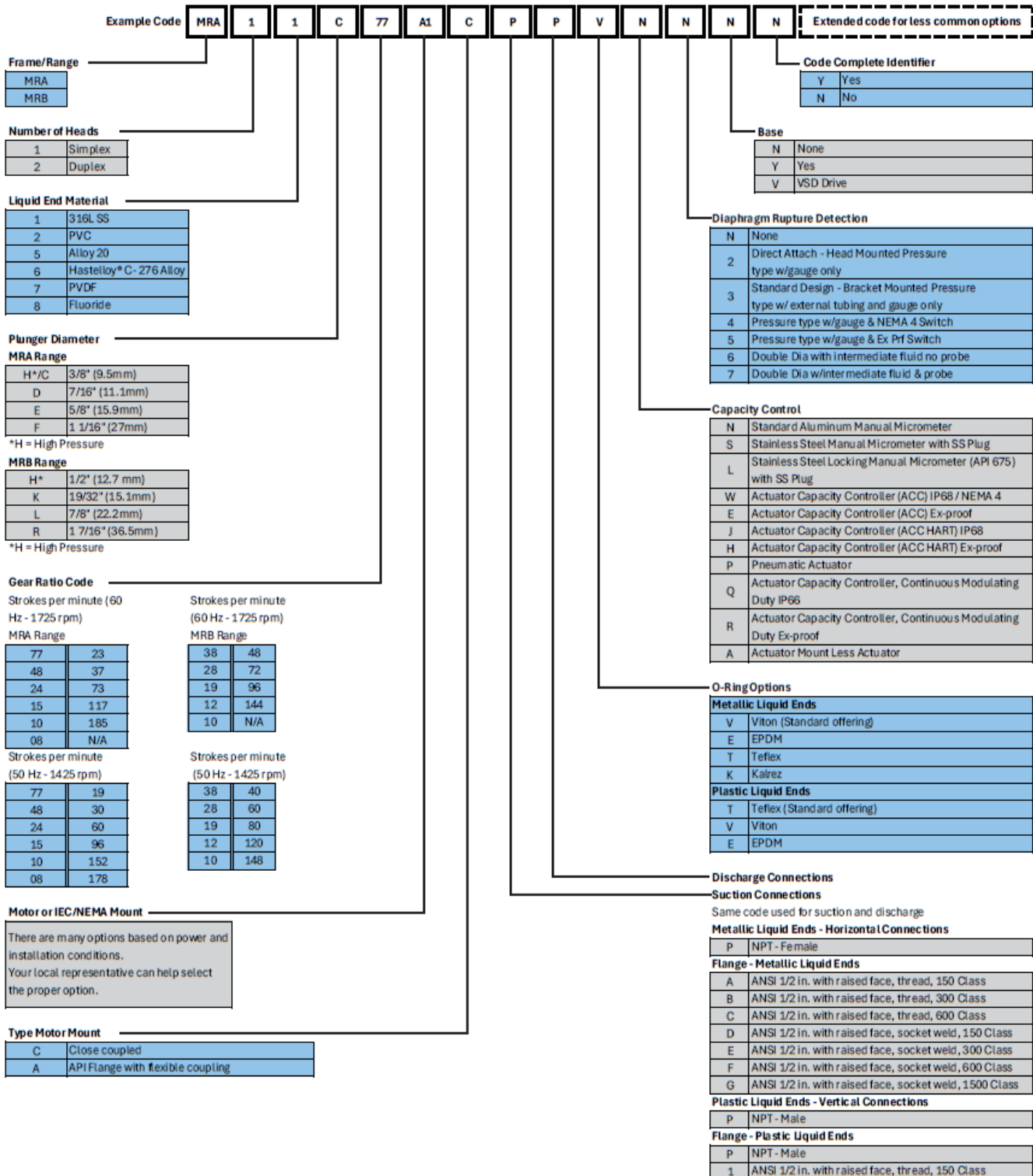


FIGURE 3. GLOBAL MRA/MRB MODEL CODE

SECTION 1 - GENERAL DESCRIPTION

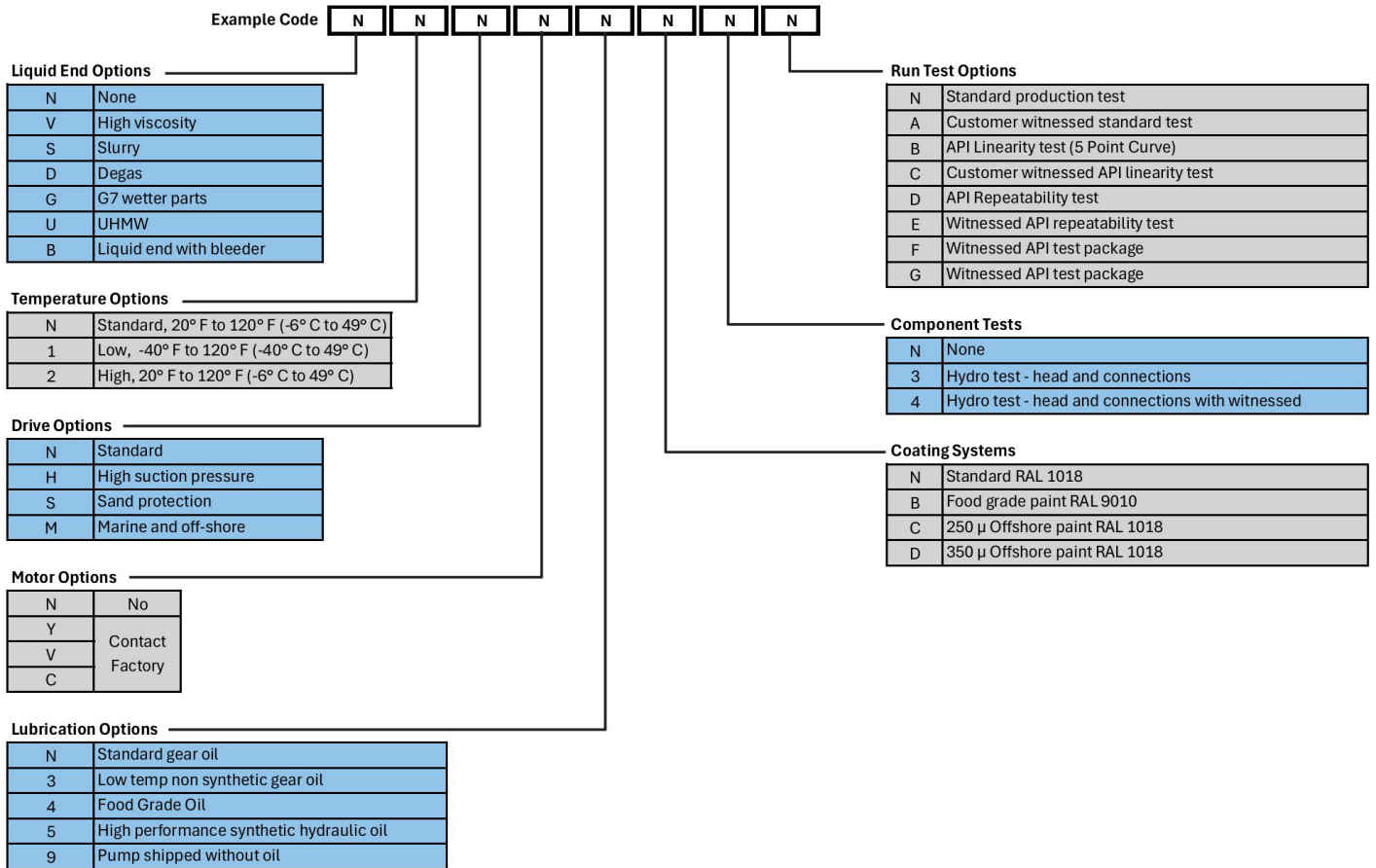


FIGURE 4. GLOBAL MRA/MRB MODEL CODE EXTRA

SECTION 1 - GENERAL DESCRIPTION

mRoy® A Routine Preventative Maintenance (RPM) Kits

Standard RPM kits for all MRA series. Kits for duplex pumps are identical; duplex pumps require 1 kit per head – 2 kits per pump total.

Plunger Dia	Plunger Code	Liquid End Material	Liquid End Type	O Ring Material	Kit Number
All MRA Plungers	C, D, E, F	316 L SS	Standard	Std (Viton)	RPM1001
				EPDM	RPM1010
				Teflex	RPM1011
			Kalrez	RPM1001K	
			Slurry	Std (Viton)	RPM1007
			High Viscosity	Std (Viton)	RPM1008
		Alloy 20	Standard	Std (Viton)	RPM1003
				EPDM	RPM1012
				Teflex	RPM1013
			Kalrez	RPM1003K	
			High Viscosity	Std (Viton)	RPM1009
			Std (Viton)	RPM1004	
	Hast C22	Standard	Kalrez	RPM1004K	
			Std (Viton)	RPM1102	
			EPDM	RPM1103	
	H	316 L SS	Standard	Teflex	RPM1104
				Kalrez	RPM1102K
				EPDM	RPM1105
			Viton	RPM1002	
			Std (Teflex)	RPM1036	
			EPDM	RPM1106	
		PVC	Standard	Viton	RPM1037
				Std (Teflex)	RPM1038
				EPDM	RPM1107
			Viton	RPM1005	
			Std (Teflex)	RPM1039	
			EPDM	RPM1108	
	C, D	PVDF	Standard	Viton	RPM1040
				Std (Teflex)	RPM1041
				EPDM	RPM1109
			Viton	RPM1006	
			Std (Teflex)	RPM1042	
EPDM			RPM1110		
Fluoride Apps		PVC - PTFE balls	Standard	Viton	RPM1043
				Std (Teflex)	RPM1044
				EPDM	RPM1043

Notes:

The above kits include two diaphragms. Contact the factory for other materials.

SECTION 1 - GENERAL DESCRIPTION

mRoy® A Routine Preventative Maintenance (RPM) Kits

Standard RPM kits for all MRA series. Kits for duplex pumps are identical; duplex pumps require 1 kit per head – 2 kits per pump total.

Double diaphragm/ Rupture detection RPM kits for all MRA series

Plunger Dia	Plunger Code	Liquid End Material	Liquid End Type	O Ring Material	Kit Number
All MRA Plungers	C, D, E, F	316 L SS	Standard	Std (Viton)	RPM1001-LD
				EPDM	RPM1010-LD
				Teflex	RPM1011-LD
			Kalrez	RPM1001K-LD	
			Slurry	Std (Viton)	RPM1007-LD
			High Viscosity	Std (Viton)	RPM1008-LD
		Alloy 20	Standard	Std (Viton)	RPM1003-LD
				EPDM	RPM1012-LD
				Teflex	RPM1013-LD
			Kalrez	RPM1003K-LD	
			High Viscosity	Std (Viton)	RPM1009-LD
			Hast C22	Standard	Std (Viton)
	Kalrez	RPM1004K-LD			
	H	316 L SS	Standard	Std (Viton)	RPM1102-LD
				EPDM	RPM1103-LD
				Teflex	RPM1104-LD
				Kalrez	RPM1102K-LD
	C, D	PVC	Standard	EPDM	RPM1105-LD
				Viton	RPM1002-LD
				Std (Teflex)	RPM1036-LD
				EPDM	RPM1106-LD
				Viton	RPM1037-LD
				Std (Teflex)	RPM1038-LD
	E, F	PVC	Standard	EPDM	RPM1107-LD
				Viton	RPM1005-LD
				Std (Teflex)	RPM1039-LD
				EPDM	RPM1108-LD
				Viton	RPM1040-LD
				Std (Teflex)	RPM1041-LD
	C, D	PVDF	Standard	EPDM	RPM1109-LD
Viton				RPM1006-LD	
Std (Teflex)				RPM1042-LD	
EPDM				RPM1110-LD	
E, F	PVDF	Standard	Viton	RPM1040-LD	
			Std (Teflex)	RPM1041-LD	
			EPDM	RPM1109-LD	
			Viton	RPM1006-LD	
C, D	Fluoride Apps	PVC - PTFE balls	Std (Teflex)	RPM1042-LD	
			EPDM	RPM1110-LD	
			Viton	RPM1043-LD	
			Std (Teflex)	RPM1044-LD	
E, F	Fluoride Apps	PVC - PTFE balls	EPDM	RPM1109-LD	
			Viton	RPM1006-LD	
			Std (Teflex)	RPM1042-LD	
			EPDM	RPM1110-LD	

Notes:

The above kits include two diaphragms. Contact the factory for other materials.

SECTION 1 - GENERAL DESCRIPTION

mRoy® B Routine Preventative Maintenance (RPM) Kits

Standard RPM kits for all MRB series. Kits for duplex pumps are identical; duplex pumps require 1 kit per head – 2 kits per pump total.

Plunger Dia	Plunger Code	Liquid End Material	Liquid End Type	O Ring Material	Kit Number
All MRB Plungers	H	316 L SS	Standard	Std (Viton)	RPM1111
				EPDM	RPM1112
				Teflex	RPM1113
	K	316 L SS	Standard	Std (Viton)	RPM1014
				EPDM	RPM1016
				Teflex	RPM1017
		Alloy 20		Std (Viton)	RPM1015
				EPDM	RPM1018
				Teflex	RPM1019
	L, R	316 L SS	Standard	Std (Viton)	RPM1020
				EPDM	RPM1021
			Teflex	RPM1022	
		Alloy 20	Standard	Std (Viton)	RPM1035
				Std (Viton)	RPM1023
			EPDM	RPM1024	
		PVC	Standard	Teflex	RPM1025
				Std (Viton)	RPM1026
				EPDM	RPM1027
		PVDF	Standard	Teflex	RPM1028
				Std (Viton)	RPM1029
				EPDM	RPM1030
Fluoride Apps (PVC w/ PTFE Balls)		Standard	Teflex	RPM1031	
			Std (Viton)	RPM1032	
			EPDM	RPM1033	
	Teflex		RPM1034		

Double diaphragm/ Rupture detection RPM kits for all MRA series

Plunger Dia	Plunger Code	Liquid End Material	Liquid End Type	O Ring Material	Kit Number
All MRB Plungers	H	316 L SS	Standard	Std (Viton)	RPM1111-LD
				EPDM	RPM1112-LD
				Teflex	RPM1113-LD
	K	316 L SS	Standard	Std (Viton)	RPM1014-LD
				EPDM	RPM1016-LD
				Teflex	RPM1017-LD
		Alloy 20		Std (Viton)	RPM1015-LD
				EPDM	RPM1018-LD
				Teflex	RPM1019-LD
	L, R	316 L SS	Standard	Std (Viton)	RPM1020-LD
				EPDM	RPM1021-LD
			Teflex	RPM1022-LD	
		Alloy 20	Standard	Std (Viton)	RPM1035-LD
				Std (Viton)	RPM1023-LD
			EPDM	RPM1024-LD	
		PVC	Standard	Teflex	RPM1025-LD
				Std (Viton)	RPM1026-LD
				EPDM	RPM1027-LD
		PVDF	Standard	Teflex	RPM1028-LD
				Std (Viton)	RPM1029-LD
				EPDM	RPM1030-LD
Fluoride Apps (PVC w/ PTFE Balls)		Standard	Teflex	RPM1031-LD	
			Std (Viton)	RPM1032-LD	
			EPDM	RPM1033-LD	
	Teflex		RPM1034-LD		

Notes:

The above kits include two diaphragms. Contact the factory for other materials.

FIGURE 5. RPM KITS

SECTION 1 - GENERAL DESCRIPTION

mRoy Series Capacity/Pressure Selection - Metallic Liquid Ends

- The capacities shown are simplex. Double capacity for duplex
- Actuators, rupture detection, and high viscosity options require capacity derating per the table on the next page
- Plastic liquid ends are limited to 150 psi - 10 bar

mRoy Series Capacity/Pressure Selection - Metallic Liquid Ends

- Capacities shown are for simplex. Double capacity for duplex
- Actuators, rupture detection, and high viscosity options require capacity derating per the table on the next page

mRoy Series	Plunger		Gear Ratio Code	Strokes/Minute		Capacity / Pressure @ 60 hz 1725 RPM						Capacity / Pressure @ 50 hz 1425 RPM					
	Diameter	Code		60 hz 1725 RPM	50 hz 1425 RPM	Ratings at 100 psi/7 bar		Capacity at Max pressure				Ratings at 100 psi/7 bar		Capacity at Max pressure			
						GPH	L/hr	Capacity		Max Pressure		GPH	L/hr	Capacity		Max Pressure	
								PSI	Bar	PSI	Bar			PSI	Bar		
A	3/8" 9.5 mm	H	77	23	19	0.35	1.3	0.19	0.7	3000	206.9	0.29	1.1	0.16	0.6	3000	206.9
			48	37	30	0.69	2.6	0.37	1.4	3000	206.9	0.58	2.2	0.31	1.2	3000	206.9
			24	73	60	1.39	5.3	0.65	2.5	3000	206.9	1.16	4.4	0.54	2.0	3000	206.9
			15	117	96	2.25	8.5	1.32	5.0	3000	206.9	1.88	7.1	1.10	4.2	3000	206.9
			10	185	152	3.53	13.4	2.04	7.7	3000	206.9	2.94	11.1	1.70	6.4	3000	206.9
	3/8" 9.5 mm	C	77	23	19	0.36	1.4	0.20	0.8	2000	137.9	0.30	1.1	0.17	0.6	2000	137.9
			48	37	30	0.73	2.8	0.34	1.3	2000	137.9	0.61	2.3	0.28	1.1	2000	137.9
			24	73	60	1.44	5.5	0.70	2.6	2000	137.9	1.20	4.5	0.58	2.2	2000	137.9
			15	117	96	2.32	8.8	1.30	4.9	2000	137.9	1.93	7.3	1.08	4.1	2000	137.9
			10	185	152	3.64	13.8	2.20	8.3	2000	137.9	3.03	11.5	1.83	6.9	2000	137.9
			08	-	178	-	-	-	-	-	-	3.55	13.4	2.14	8.1	2000	137.9
			08	-	178	-	-	-	-	-	-	3.55	13.4	2.14	8.1	2000	137.9
	7/16" 11.1 mm	D	77	23	19	0.57	2.2	0.4	1.5	1800	124.1	0.48	1.8	0.33	1.2	1800	124.1
			48	37	30	0.8	3	0.6	2.3	1800	124.1	0.67	2.5	0.50	1.9	1800	124.1
			24	73	60	1.7	6.4	1.2	4.5	1800	124.1	1.42	5.4	1.00	3.80	1800	124.1
			15	117	96	2.8	10.6	2	7.6	1800	124.1	2.33	8.8	1.67	6.30	1800	124.1
			10	185	152	4.4	16.7	3.1	11.7	1800	124.1	3.67	13.9	2.58	9.80	1800	124.1
	5/8" 15.9 mm	E	48	37	30	1.8	6.8	1.4	5.3	925	63.8	1.50	5.7	1.2	4.4	925	63.8
			24	73	60	3.8	14.4	3.1	11.7	925	63.8	3.17	12	2.6	9.8	925	63.8
			15	117	96	6.2	23.5	5.1	19.3	925	63.8	5.17	19.6	4.3	16.1	925	63.8
			10	185	152	9.4	35.6	7.7	29.1	925	63.8	7.83	29.6	6.4	24.3	925	63.8
			08	-	178	-	-	-	-	-	-	9.17	34.7	7.5	28.5	925	63.8
	1 - 1/16" 27 mm	F	48	37	30	6.1	23.1	5.5	20.8	350	24.1	5.08	19.2	4.6	17.3	350	24.1
			24	73	60	12.3	46.6	11.2	42.4	350	24.1	10.25	38.8	9.3	35.3	350	24.1
			15	117	96	19.4	73.4	18.1	68.5	350	24.1	16.17	61.2	15.1	57.1	350	24.1
			10	185	152	30.0	113.6	29.0	109.8	200	13.8	25.00	94.6	24.2	91.5	200	13.8
			08	-	178	-	-	-	-	-	-	29.28	110.8	28.3	107.1	200	13.8
	B	1/2" 12.7 mm	H	38	48	40	3.3	12.5	2.5	9.5	3000	206.9	2.8	10.6	2.1	7.9	3000
25				72	60	5.0	18.9	3.8	14.4	3000	206.9	4.2	15.9	3.2	12.0	3000	206.9
19				96	80	6.9	26.1	5.0	18.9	3000	206.9	5.7	21.6	4.2	15.8	3000	206.9
12				144	120	9.4	35.6	8.0	30.3	3000	206.9	7.9	29.9	6.7	25.2	3000	206.9
10				-	148	-	-	-	-	3000	206.9	9.7	36.7	8.2	31.1	3000	206.9
19/32" 15.1 mm		K	38	48	40	4.7	17.8	3.3	12.5	1500	103.4	3.92	14.8	2.8	10.4	1500	103.4
			25	72	60	7.0	26.5	5.6	21.2	1500	103.4	5.83	22.1	4.7	17.7	1500	103.4
			19	96	80	9.5	36	7.1	26.9	1500	103.4	7.92	30	5.9	22.4	1500	103.4
			12	144	120	13.3	50.3	11.4	43.1	1500	103.4	11.08	41.9	9.5	36.0	1500	103.4
			10	-	148	-	-	-	-	1500	103.4	13.67	51.7	11.72	44.3	1500	103.4
7/8" 22.2 mm		L	38	48	40	10.0	37.9	4.7	17.8	1000	69	8.33	31.5	3.9	14.8	1000	69
			25	72	60	16.0	60.6	11.0	41.6	1000	69	13.33	50.5	9.2	34.7	1000	69
			19	96	80	21.0	79.5	16.0	60.6	1000	69	17.50	66.2	13.3	50.5	1000	69
			12	144	120	30.4	115.1	25.6	96.9	1000	69	25.33	95.9	21.3	80.7	1000	69
			10	-	148	-	-	-	-	1000	69	31.24	118.2	26.31	99.6	1000	69
1 - 7/16" 36.5 mm		R	38	48	40	27.0	102.2	21.0	79.5	400 †	27.6 †	22.50	85.2	17.5	66.2	400 †	27.6 †
			25	72	60	42.0	159	36.0	136.3	400 †	27.6 †	35.00	132.5	30.0	113.6	400 †	27.6 †
			19	96	80	57.0	215.7	51.0	193	400 †	27.6 †	47.50	179.8	42.5	160.9	400 †	27.6 †
			12	144	120	85.0	321.7	79.0	299	400 †	27.6 †	70.83	268.1	65.8	249.2	400 †	27.6 †
			10	-	148	-	-	-	-	400 †	27.6 †	87.36	330.6	81.19	307.3	400 †	27.6 †

NOTES: † Duplex MRB pumps with plunger code "R" with gear codes 10, 12, or 19 are limited to 250 psi (17 bar)
‡ Duplex MRB pumps with plunger code "R" with gear codes 25 and 38 are limited to 350 psi (20.7 bar)
Duplex MRA pumps with 2 different size plunger can achieve max 350 psi (24.1 bar) only
MRA/MRB pumps plunger code "H" available in Simplex configuration only

FIGURE 7. MROY A&B METALLIC LIQUID END CAPACITY TABLES

SECTION 1 - GENERAL DESCRIPTION

mRoy Series Capacity/Pressure Selection - Plastic Liquid Ends

- Includes PVC, PVDF liquid ends, and liquid ends for Fluoride applications
- The capacities shown are simplex. Double capacity for duplex
- Actuators, rupture detection, and high viscosity options require capacity derating per the table on the next page
- Please note that plastic liquid ends are not available for plunger code "K" - mRoy B frame with 19/32" (15.1 mm) plunger.

mRoy Series	Plunger		Gear Ratio Code	Strokes/Minute		Capacity / Pressure @ 60 hz 1725 RPM						Capacity / Pressure @ 50 hz 1425 RPM					
				60 hz 1725 RPM	50 hz 1425 RPM	Ratings at 100 psi/7 bar		Capacity at Max pressure				Ratings at 100 psi/7 bar		Capacity at Max pressure			
	Diameter	Code		GPH	L/hr	GPH	L/hr	PSI	Bar	GPH	L/hr	PSI	Bar	GPH	L/hr	PSI	Bar
A	3/8" 9.5 mm	C	77	23	19	0.32	1.2	0.28	1.1	150	10.3	0.27	1	0.23	0.9	150	10.3
			48	37	30	0.68	2.6	0.62	2.3	150	10.3	0.57	2.2	0.52	2	150	10.3
			24	73	60	1.35	5.1	1.30	4.9	150	10.3	1.13	4.3	1.08	4.1	150	10.3
			15	117	96	2.20	8.3	2.10	7.9	150	10.3	1.83	6.9	1.75	6.6	150	10.3
	7/16" 11.1 mm	D	77	23	19	0.5	1.9	0.45	1.7	150	10.3	0.42	1.6	0.38	1.4	150	10.3
			48	37	30	0.7	2.6	0.65	2.5	150	10.3	0.58	2.2	0.54	2	150	10.3
			24	73	60	1.5	5.7	1.4	5.3	150	10.3	1.25	4.7	1.17	4.40	150	10.3
			15	117	96	2.5	9.5	2.4	9.1	150	10.3	2.08	7.9	2.00	7.60	150	10.3
	5/8" 15.9 mm	E	48	37	30	1.6	6.1	1.5	5.7	150	10.3	1.33	5	1.3	4.7	150	10.3
			24	73	60	3.5	13.2	3.4	12.9	150	10.3	2.92	11.1	2.8	10.7	150	10.3
			15	117	96	5.6	21.2	5.5	20.8	150	10.3	4.67	17.7	4.6	17.3	150	10.3
	1- 1/16" 27 mm	F	48	37	30	5.7	21.6	5.6	21.2	150	10.3	4.75	18	4.7	17.7	150	10.3
			24	73	60	11.3	42.8	11.2	42.4	150	10.3	9.42	35.7	9.3	35.3	150	10.3
			15	117	96	18.1	68.5	18.0	68.1	150	10.3	15.08	57.1	15.0	56.8	150	10.3

FIGURE 8. MROY A PLASTIC LIQUID END CAPACITY TABLES

B	7/8" 22.2 mm	L	38	48	40	10.0	37.9	4.7	17.8	150	10.3	8.33	31.5	3.9	14.8	150	10.3
			25	72	60	16.0	60.6	11.0	41.6	150	10.3	13.33	50.5	9.2	34.7	150	10.3
			19	96	80	21.0	79.5	16.0	60.6	150	10.3	17.50	66.2	13.3	50.5	150	10.3
			12	144	120	30.4	115.1	25.6	96.9	150	10.3	25.33	95.9	21.3	80.7	150	10.3
			10	-	148	-	-	-	-	150	10.3	31.24	118.2	26.31	99.6	150	10.3
	1- 7/16" 36.5 mm	R	38	48	40	27.0	102.2	21.0	79.5	150	10.3	22.50	85.2	17.5	66.2	150	10.3
			25	72	60	42.0	159	36.0	136.3	150	10.3	35.00	132.5	30.0	113.6	150	10.3
			19	96	80	57.0	215.7	51.0	193	150	10.3	47.50	179.8	42.5	160.9	150	10.3
			12	144	120	85.0	321.7	79.0	299	150	10.3	70.83	268.1	65.8	249.2	150	10.3
			10	-	148	-	-	-	-	150	10.3	87.36	330.6	81.19	307.3	150	10.3

FIGURE 9. MROY B PLASTIC LIQUID END CAPACITY TABLES

SECTION 1 - GENERAL DESCRIPTION

Horsepower / kW Requirements

The following are minimum values required. The use of variable speed drives may require higher power motors to operate at low RPM.

Frame		A			B					
Plunger Code		H	C, D, E, F	H	K		L		R	
					< 1000 psi/69 bar	> 1000 psi/69 bar	< 400 psi/26.7 bar	> 400 psi/26.7 bar	< 100 psi/7 bar	> 100 psi/7 bar
1 Ph	Simplex	1/3 HP(0.25 kW)	1/4 HP(0.18 kW)	1 HP (0.75 kW)	3/4 HP (0.55 kW)	3/4 HP (0.55 kW)	3/4 HP (0.55 kW)	1 HP (0.75 kW)	3/4 HP (0.55 kW)	1 HP (0.75 kW)
	Duplex	-	1/3 HP(0.25 kW)		1 HP (0.75 kW)	1 HP (0.75 kW)	1 HP (0.75 kW)	1 HP (0.75 kW)	1 HP (0.75 kW)	1 HP (0.75 kW)
3 Ph	Simplex	1/3 HP(0.25 kW)	1/4 HP(0.18 kW)	1 HP (0.75 kW)	1/2 HP (0.37 kW)	3/4 HP (0.55 kW)	1/2 HP (0.37 kW)	3/4 HP (0.55 kW)	1/2 HP (0.37 kW)	3/4 HP (0.55 kW)
	Duplex	-	1/3 HP(0.25 kW)		3/4 HP (0.55 kW)	1 HP (0.75 kW)	3/4 HP (0.55 kW)	1 HP (0.75 kW)	3/4 HP (0.55 kW)	1 HP (0.75 kW)

NOTE:

All motor manufacturers note that general duty totally enclosed motors are equivalent to IP54 or below, and thus not suitable for outdoor or washdown areas without protection. For outdoor and washdown applications, use washdown duty IP55 or above rated motors. This is especially true for vertically mounted applications, which includes the mRoy series.

Motor manufacturers also note that Explosion Proof Fan Cooled motors are not recommended for outdoor or washdown areas without protection. Non-ventilated explosion proofs are recommended for outdoor use.

mRoy PUMP FLOW DERATING TABLE

mRoy Frame	A				B			
	3/8" 9.5 mm	7/16" 11.1 mm	5/8" 15.9 mm	1-1/16" 27 mm	1/2" 12.7 mm	19/32" 15.1 mm	7/8" 22 mm	1 - 7/16" 37 mm
Plunger Code	H / C	D	E	F	H	K	L	R
Electronic or Pneumatic Capacity Control	0.95	0.95	0.95	0.95	0.90	0.90	0.90	0.90
Diaphragm Rupture Detection System	0.95	0.95	0.95	0.95	0.95	0.95	0.95	0.95
Double Diaphragm	-	-	0.95	0.95	-	-	-	-
High Viscosity Option	-	0.90	0.90	0.90	-	-	-	-

NOTE:

Certain options require that the maximum capacity be derated. Multiply capacities in the capacity / pressure tables in Figures 6 through 9 by the appropriate factors in the table above.

FIGURE 10. MROY PUMP (ALL MODELS) CAPACITY DERATING TABLE

SECTION 2 - INSTALLATION



Always wear appropriate personal protective equipment and clothing. Unpack with care since the presence of nails or staples may cause cuts.

2.1 UNPACKING / INSPECTION

Units are shipped Ex Works and the title passes to the customer when the carrier signs for receipt of the unit. In the event that damage occurs during shipment, it is the responsibility of the customer to notify the carrier immediately and to file a damage claim. Carefully examine the shipping crate upon receipt from the carrier to be sure there is no obvious damage to the contents. Open the crate carefully so accessory items fastened to the inside of the crate will not be damaged or lost. Examine all material inside the crate and check against the packing list to be sure that all items are accounted for and intact.

2.2 STORAGE

Short Term Storage (Less than 6 Months)

It is preferable to store the material under a shelter in its original package to protect it from adverse weather conditions. In condensing atmospheres, follow the long-term storage procedure.

Long Term Storage (Longer than 6 Months) The primary consideration in storage of pump equipment is to prevent corrosion of external and internal components. This corrosion is caused by natural circulation of air as the temperature of the surroundings changes from day to night, day to day, and from season to season. It is not practical to prevent this circulation which carries water vapor and other corrosive gases, so it is necessary to protect internal and external surfaces from their effects to the greatest extent possible. When the instructions given in this section are completed, the equipment is to be stored in a shelter; protected from direct exposure to weather. The prepared equipment should be covered with a plastic sheet or a tarpaulin, but in a manner which will allow air circulation and prevent capture of moisture. Equipment should be stored 12 inches (.304 meters) or more above the ground.

If equipment is to be shipped directly from Milton Roy into long-term storage, contact Milton Roy to arrange long-term storage preparation.

Pump Drive

1. Remove motor and flood the gearbox compartment with a high-grade lubricating oil/rust preventative Mobile Oil Corporation product Mobilarma 524 or approved equivalent. Fill the compartment completely to minimize air space. After storage, drain this oil and refill the equipment with the recommended lubricant for equipment commissioning.
2. Brush all unpainted metal surfaces with multipurpose grease NLGI grade 2 or 3 or approved equivalent. Store these unattached.

Electrical Equipment

1. Motors should be prepared in the manner prescribed by their manufacturer. If information is not available, dismount and store motors as indicated in step 3 below.
2. Dismount electrical equipment (including motors) from the pump.
3. For all electrical equipment, place packets of Vapor Phase Corrosion Inhibitor (VPCI) inside of the enclosure, then place the entire enclosure, with additional packets, inside a plastic bag. Seal the bag tightly closed. Contact Milton Roy Service Department for recommended VPCI materials.

2.3 SAFETY PRECAUTIONS

When installing, operating, and maintaining the mRoy pump, keep safety considerations foremost. Use proper tools, protective clothing, and eye protection when working on the equipment and install the equipment in compliance with NEC, NEPA and local codes. Follow the instructions in this manual and take additional safety measures appropriate to the liquid being pumped. Be extremely careful in the presence of hazardous substances (e.g., corrosives, toxics, solvents, acids, caustics, flammables, etc.).

2.4 PUMP MOUNTING & LIFTING / LOCATION

During handling, ensure nobody is in the pump handling area. The operator shall never be under the package during lifting

The mRoy pump can be mounted on any surface that is flat and level for the support feet. Three mounting bolt holes are provided in the support feet for use when the pump is to be firmly anchored to a base surface (see Figure 14.)

Increased reliability can be expected if pump locations are avoided which are subjected to high ambient temperatures above 100°F (38°C) with poor free-air circulation over the pump assembly.

Lifting

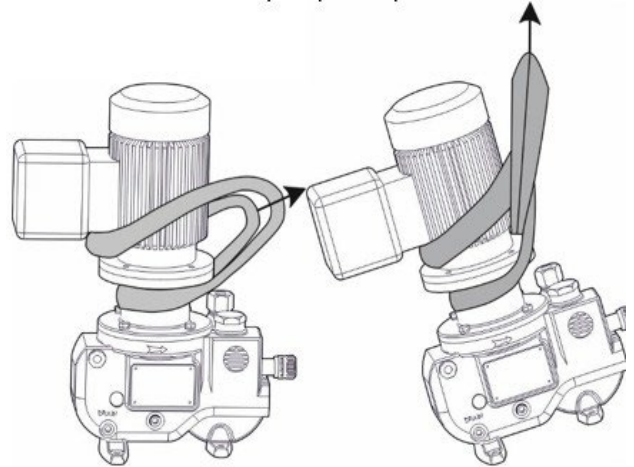
Put the sling under the motor terminal box and under the motor flange. Cross the two ends of the sling and close the loop (see diagrams). Before attempting to move it, check that the entire unit is well balanced.

Note: As soon as the pump is in position, fasten it down.

2.5 OUTDOOR INSTALLATIONS

The mRoy pump is designed as a totally enclosed unit suitable for installation either indoors or outdoors. However, for outdoor installations the pump mounting area should be selected to provide protection against environmental extremes:

1. Operation with continuous exposure to sunshine with ambient temperatures above 90°F (32°C), which would cause higher oil temperatures and reduce lubricity should be avoided. Good installation practice would dictate providing a sunshade over the pump with open sides to obtain the best air circulation around the pump.
2. Frequent start-up where the pump has been idle in an ambient temperature below 30°F (-1°C) is not recommended. Provide a removable, insulated enclosure over the pump and mounting base with provisions for an electrical heater (100-watt light, heat lamp, heater tape etc.) to maintain the pump oil temperature above 30°F (-1°C).



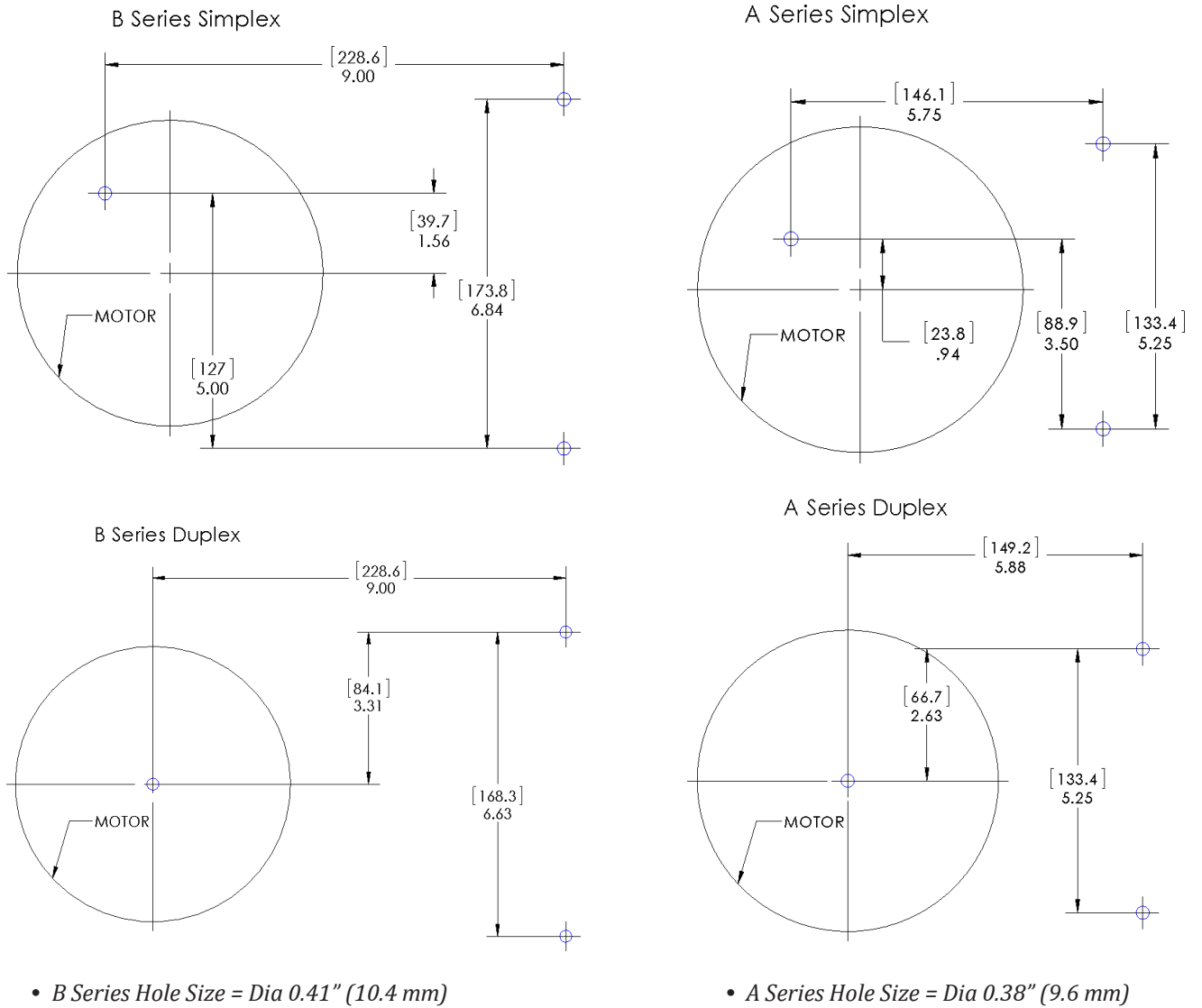


FIGURE 11. MOUNTING BOLT HOLES

2.6 FLANGE MOUNTED MOTORS

If API motor mount option was selected for the mRoy pump, the customer supplied motor will need to be mounted to the pump. This is generally a straightforward procedure. Refer to Figure 14 or 15, as appropriate.

When mounting the motor to a Close Coupled Flange, the motor mount plate (710) must be removed from the pump body and bolted to the motor. The motor/motor mount plate assembly can then be bolted to the pump.

2.7 ELECTRICAL CONNECTIONS

Check to be sure that the electrical supply matches the pump motor nameplate electrical characteristics. Motor rotation must be counterclockwise when viewed from the top end of the motor.

CAUTION ON SINGLE-PHASE PUMP MOTORS THE ROTATION WILL BE DETERMINED AT THE FACTORY AND MUST NOT BE CHANGED. ON THREE-PHASE PUMP MOTORS THE ROTATION MUST BE DETERMINED AT THE TIME OF INSTALLATION AND PRIOR TO START-UP. OPERATION WITH THE WRONG ROTATION WILL DAMAGE THE PUMP AND MOTOR AND VOID THE WARRANTY. SHAFT ROTATION CAN BE OBSERVED BY REMOVING THE COVER PLATE OVER THE ELECTRICAL CONNECTIONS.

Wiring is to be done by a person with the appropriate competence / training and electrical clearance license. The person doing the wiring shall wear proper Personal Protection Equipment. The electrical wiring is to be done with the power supply off and locked. Make sure the ground wire is connected and the unit is grounded. For any control wiring, refer to any control panel wiring diagram provided by the manufacturer. Close the terminal box after the electrical connections are made.

2.8 MOTORS

Motor is normally a totally enclosed non-ventilated, type, that is mounted on a 56C-face flange or IEC Frame 71 flange. The gear reducer (worm shaft) fits onto the standard motor without using a coupling.

On the larger mRoy B, the normal temperature rise for these motors is 50°C above ambient temperature, and it can be expected that these motors will appear to operate at higher temperatures than are normally experienced. However, there is no cause for worry if the following precautions are observed:

1. The motor is placed where there is adequate ventilation and is protected against excessive radiation from steam pipes and other heat sources.
2. The overload heater in the starting device should be correctly sized for motor full load current rating as shown on the motor data plate.

Note: For motor that is supplied by the customer, Milton Roy is not responsible for any damage resulting from an improper installation or for a motor that is not suitable for the selected environment.

2.9 PUMP LUBRICATION

CAUTION CAREFULLY UNSCREW TO REMOVE OIL RESERVOIR CAP. DO NOT APPLY PRESSURE TO JOG CAP FROM SIDE TO SIDE OR DIP STICK MAY BREAK.

Oil is supplied for average installation (ambient temperature above 50°F (10°C)). See recommendation below for lower temperature. Fill pump and gear box by slowly pouring the recommended oil through the air bleed reservoir opening until the oil level in the reservoir is level with oil level mark on outside surface of reservoir. Level can be checked by looking at sight glass on side of the pump. Recheck while pump is operating. Oil needs to fill in small cavities deep inside pump and level may drop below minimum oil level once running. Pump will not pump until oil level is correct and air is removed from oil.

CAUTION DO NOT OVER FILL AS MOTOR DAMAGE CAN RESULT.

SECTION 2 - INSTALLATION

NOTE:

Synthetic oils are available that span the entire temperature range. Contact Milton Roy for further information.

MR Part #s shown below in bold.

PUMP TYPE	CODE	RATIO	STANDARD (N)	LOW TEMP NON-SYNTHETIC 15°F TO 50°F (3)	FOOD GRADE OIL NEVASTANE (4)	HIGH PERFORMANCE SYNTHETIC (5) (OPTIONS 1 & 2 TEMP EXT OPT. -40 °F TO 120 °F)	QTY. REQUIRED (IN QUARTS)
MRA	77	77:1	4070152010 GEAR OIL, ISO 220, 1 QT	4070195010 GEAR OIL, ISO 68, 1 QT	41492 NEVASTANE OIL ISO 220, 1 QT	20040 SYN. HYD. FLUID, ISO 32, 1 QT	SIMPLEX - 1
	48	48:1					
	24	24:1					
	15	15:1	4070195010 GEAR OIL, ISO 68, 1 QT				DUPLEX - 2
	10	9.5:1					
8	8:1						
MRB	38	38:1	4070152010 GEAR OIL, ISO 220, 1 QT	4070195010 GEAR OIL, ISO 68, 1 QT	41492 NEVASTANE OIL ISO 220, 1 QT	20040 SYN. HYD. FLUID, ISO 32, 1 QT	SIMPLEX - 3
	25	25:1					
	19	19:1					
	12	12.5:1	DUPLEX - 4				
	10	9.5:1					

2.10 PIPING

General

Refer to Figure 12 for a diagram of a typical Piping and Instrumentation Diagram.

Support all piping connections to the pump so that no stress is placed on pump fittings. In no case should the piping be sprung to make the connections to the pump. The suction and discharge cartridge pipe connections can be positioned within an arc of approximately 150° to facilitate piping to pump.

Flush and blow out all pipelines before connecting the pump. This eliminates any foreign matter that might seriously damage the internal working parts of the liquid end. Install a 20 mesh Y-type strainer that is sized to remove foreign particles with minimum pressure drop in the suction line of the pump. It is also recommended to perform a leak test of the system with a neutral liquid before pressured start-up of the final installation.

Install shut-off valves, with unions on the pump side of the valves, in the suction and discharge lines to facilitate servicing.

Use extreme care in piping to plastic liquid end pumps with rigid pipe such as PVC. If excessive stresses or vibration is unavoidable, flexible connections are recommended.

NOTE:

Many pipe joint compounds are not suitable for use with plastic pipe and, if used, will cause stress cracking at the connection. Use only compounds commended for use with plastic materials.

Suction Piping

The suction piping must be absolutely tight and leak free. For mRoy pumps on water-like solutions we recommend that the suction pipe be ¾" minimum diameter and a maximum of 6 feet (2 meters) long. The intent is that the piping must be designed to provide an adequate net positive suction head (NPSH). Obtain our NPSH Calculation software at the Milton Roy website (www.miltonroy.com). If assistance in determining NPSH is needed, contact the Milton Roy Aftermarket Service department through the website (www.miltonroy.com)

SECTION 2 - INSTALLATION

A flooded suction is recommended for optimum service life and maintenance-free operation. However, the mRoy pump can operate with less than flooded suction if necessary, in accordance with the following schedule shown in the chart below.

	MODEL NUMBER	MIN. NPSH (PSI)	MAX. LIFT (FT. H ₂ O)
MROY A	MRA	10	10
MROY B	MRB	10	10

Refer to “Installation with Suction Lift,” which outlines limiting conditions if suction lift requirements are anticipated.

The supply tank should incorporate a low-level switch to cut off the pump motor before the suction intake is exposed to air. Otherwise, the pump may occasionally run dry.

Discharge Piping

The installation of an external Safety Valve is recommended, since the pump’s internal relief valve is not intended to protect the piping system.

Refer to “Setting the Relief Valve” in Section 3, for further relief valve discussion. (Milton Roy offers a complete line of back pressure and safety valves).

For satisfactory metering and capacity control, the differential pressure at the pump must be 50 PSI (3.5 Bar) minimum for the mRoy A and 70 PSI (4.8 Bar) minimum for the mRoy B.

Therefore, when the pump is to be discharged; into an open system, a back pressure device must be installed in the pump discharge line.

CAUTION REMOTE HEAD SYSTEMS: DO NOT INSTALL A BACK PRESSURE SPRING IN DISCHARGE BALL CHECK CARTRIDGE OF DIAPHRAGM HEADS WHICH ARE “REMOTE MOUNTED” (NOT ATTACHED TO THE MAIN HOUSING). A SEPARATE BACK PRESSURE VALVE MUST BE INSTALLED IN THE DISCHARGE LINE FROM THE REMOTE HEAD CARTRIDGE.

Static Leak Test

A static leak test is to be performed on the pump liquid end and piping prior to the introduction of the pumped chemical. The person conducting the static leak test shall wear appropriate and proper Personal Protection Equipment.

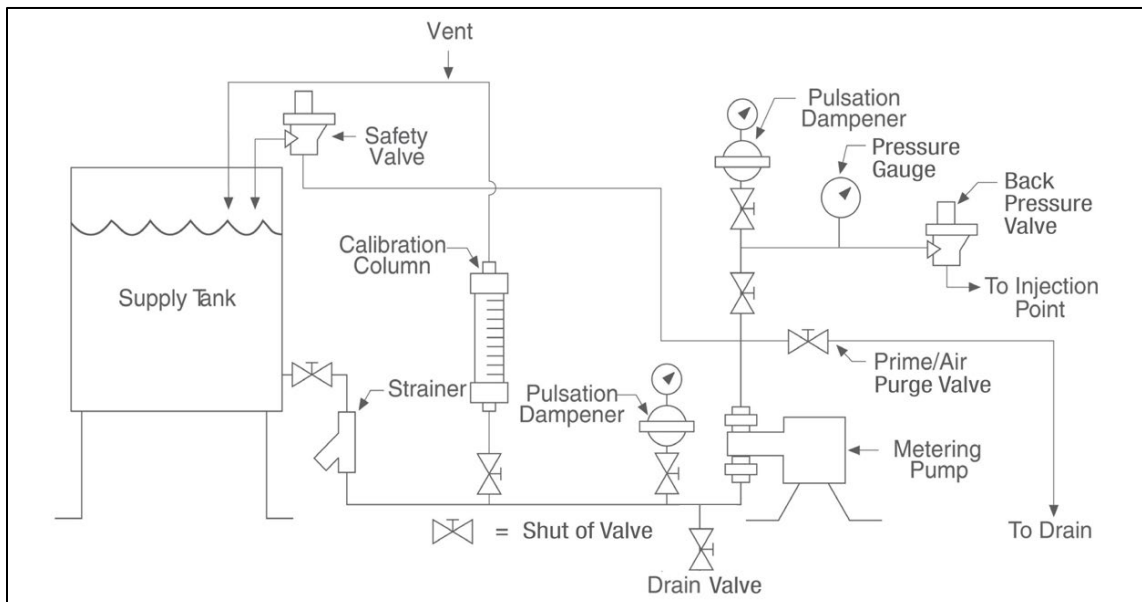


FIGURE 12. TYPICAL PIPING AND INSTRUMENTATION DIAGRAM

SECTION 2 - INSTALLATION



2.11 OPERATION WITH SUCTION LIFT

It is desirable that the mRoy pump operate with a flooded suction; however, operation with net positive suction head (NPSH) less than atmospheric pressure is possible.

NPSH is the head available, above the vapor pressure of the liquid being pumped, to feed the liquid into the pump suction port. NPSH minimum is the head below which the pump cavitates.

Both values are calculated at the suction port of the pump. In controlled volume pump applications, two conditions must be considered in the selection of a pump to meet the NPSH minimum requirements:

1. At the start of the suction stroke, the liquid in the suction line has no velocity and NPSH minimum depends on the force necessary to accelerate the liquid in the suction pipeline.
2. At the peak of the suction stroke there is no acceleration factor and NPSH minimum depends on friction losses as calculated from standard flow equations. With all viscous liquids and in pilot plants and other places where unusual numbers of fittings and valves are used, the second condition that includes friction losses should be considered. For water-like liquids, the first condition will define the limiting configuration.

NPSH (Condition 1)

Available NPSH = $P_a + P_h - P_{acc} - P_v$ (must be equal to or greater than minimum NPSH as listed under Installation Instructions).

$$P_{acc} = \frac{\text{Sp. Gr. (0.0925)} L_p D}{D_p^2}$$

NPSH (Condition 2)

Available NPSH = $P_a \pm P_h - P_f L_e - P_v$ (must be equal to or greater than minimum NPSH as listed under Installation Instructions).

D = Plunger Diameter (inches)

D_p = Pipe Diameter (inches)

L_p = Actual Length of suction pipe (feet)

L_e = Equivalent length of suction pipe including allowance for fittings (feet)

P_a = Ambient pressure above liquid (PSI)

P_h = Head of liquid column above (+) or below (-) center line of plunger (PSI) equals Head in feet x (0.435) (Sp.Gr.)

P_v = Vapor pressure of liquid (PSI)

P_f = Friction loss per foot of pipe calculated from Reynold Number evaluation (PSI) (Use 3.2 times average velocity for calculating friction losses when referring to a standard pipe losses table)

Minimum NPSH = Minimum hydraulic pressure at plunger (listed under Installation Instructions).

When operating the pump with a NPSH of less than atmospheric pressure (negative suction head or suction lift), special attention should be given to keep the suction line strainer clean and prevent other system conditions that might inadvertently decrease the NPSH available.

NOTE:

Obtain our NPSH calculation software at the Milton Roy website (miltonroy.com). If assistance in determining NPSH is needed, contact the Milton Roy Aftermarket Service Department.

3.1 INITIAL START-UP

⚠ WARNING WEAR ALL THE NECESSARY PERSONAL PROTECTIVE EQUIPMENT FOR ANY WORK ON OUR EQUIPMENT. ALL CUSTOMARY SAFETY PRECAUTIONS MUST BE TAKEN APPROPRIATE TO THE CHEMICAL PRODUCTS USED IN THE PROCESS (ACIDS, BASES, ETC.)

Before initial start-up of the pump, check the following:

⚠ WARNING FAILURE TO CHECK TORQUE ON NON-METALLIC HEAD PRIOR TO STARTUP AND AFTER ONE WEEK OF OPERATION MAY EXPOSE OPERATING PERSONNEL TO HAZARDOUS LIQUIDS.

1. Check the torque on all non-metallic head bolts prior to startup. After one week of operation, re-torque all nonmetallic head bolts. Torque the head assembly screws in a crosswise pattern (Figure 13) as follows:
 - a) mRoy Model A Plastic Heads: 60–70 in. lbs. (7-8 N-m) bolting torque.
 - b) mRoy Model B Plastic Heads: 75–85 in. lbs. (8.5-9.6 N-m) bolting torque, tie down nuts 25 in. lbs. (3 N-m).

NOTE: All mRoy pumps are shipped with internal pressure relief valve set to approx. 125 psig unless instructions with order require a different setting. This will limit the discharge pressure of the pump. If higher setting is desired, refer to item 3.2

2. Check/ fill the oil level in reservoir up to be slightly above the indicated oil level.
3. Make certain that the suction line, liquid end and discharge cartridge are filled with water or system liquid.
4. Relieve all back pressure in the discharge line and pump hydraulic system to allow air to purge. Refer to “Start-Up after the Suction System has Run Dry” section.
5. If practical, install a temporary discharge line piped back to the suction tank incorporating a 100 PSI (7 Bar) relief valve to facilitate establishing performance during first hours of operation.

6. Check for product leaks during the first 1/2 day of operation.

If the pump has an electronic stroke adjust actuator, then

1. This is to be operated by authorized staff.
2. Turn off the power when working on the terminal box. Watch for and avoid any residual energies.
3. During the first hour of start-up, check for any cables getting hot or suspicious electrical noise.
4. While testing, we recommend changing the milliamp control signal by 5mA increments.

Priming

In order to prime the pump, it is necessary to purge the liquid end (to release air) by the bleeder valve (360). This is a metal-to-metal seal. For toxic liquids, it is recommended to attach chemically compatible tube to barbed fitting (360) to collect this fluid to safe drain point during this operation.

- First turn the pump ON
- Place the micrometer on the 50% position, for 10 minutes.
- Loosen the bleeder valve (360) by around 1/4 turn located on the liquid end.

Thus, the air trapped in the suction piping and the pump head can escape via the barbed fitting. Wait until the liquid comes up to the evacuation level of this drain. Let it flow for a few seconds in order to degas it completely, then retighten the drain plug.

Check for proper motor rotation as described in general installation instructions. On initial (after filling with oil) priming of pump hydraulics start-up with 0% capacity, run the pump for 10–20 seconds, then stop for 20–30 seconds. Repeat a few times in order to fill the diaphragm oil cavity. During these short runs listen for any abnormal motor or crank noises, and if present, refer to Section 5, Troubleshooting. Priming pump hydraulics is only required after each oil replacement. Run pump for 1/2 to 1-1/2 hours to warm up oil.

SECTION 3 - OPERATION

Check the discharge line for indication of flow. Increase capacity adjustment setting to 100% of capacity and operate for 10–20 minutes.

⚠ CAUTION DO NOT SET THE CAPACITY ADJUSTMENT KNOB IN EXCESS OF 100% BECAUSE ERRATIC OR REDUCED METERING WILL DEVELOP.

Reduce capacity adjustment setting to 30–40% of maximum capacity and operate for several minutes, then increase capacity adjustment back to 100% for approximately 10 minutes. Repeat several times to insure that the air is bled from the pump hydraulic chamber and the liquid end. (As a general rule, to bleed air or vapor from the pump oil displacement chamber reduce the capacity adjustment to the 20 to 40% range, and to bleed air or vapor from the liquid end increase capacity to 100%, or if possible, reduce the discharge pressure to atmospheric pressure for 30 seconds to one minute).

The pump is now ready for calibration. Calculate the desired capacity as a percentage of the maximum capacity rating on the pump data plate. Each pump is tested at maximum pressure at the factory to confirm that the performance meets these capacity-pressure requirements (tested with water). Flowrate decreases slightly as pressure increases. See figures 6, 7, 8, and 9. Milton Roy offers a complete line of calibration columns for calibrating the pump.

Start-Up after the Suction System has Run Dry In applications where the suction tank does not have a low level cutoff interconnected into the pump motor circuit, the pump may occasionally run dry. This should be avoided to ensure full integrity of the diaphragm. Running the pump dry occasionally for no longer than 2 minutes will not harm the diaphragm or the pump. However, when the pump is repeatedly allowed to run dry, especially for long periods of time, the diaphragm is fatigued and could fail before the next scheduled replacement.

Before restarting a pump that has run dry, provisions should be made for filling the liquid end with liquid by opening the discharge line to atmospheric pressure to either refill liquid end with flooded suction pressure or start pump with open discharge and run for

a short period of time (up to 2 minutes) that will ‘prime’ the liquid end if the ball checks are wet. If these steps fail, remove the discharge cartridge and fill liquid end with liquid through the top discharge opening in the head. After establishing flow, return to the regular discharge system configuration.

3.2 RESETTING THE RELIEF VALVE

The mRoy pump incorporates an internal relief valve that is preset at the factory to relieve when the hydraulic liquid pressure exceeds 125 PSI (8.6 Bar). This setting can be readjusted as required up to 15% above the maximum nameplate rated pressure of the pump. The relief valve limits the pressure the pump can develop and resetting the internal relief valve will change the potential discharge pressure of the pump.

Refer Figure 15 for a pictorial description of the mechanism.

Examination of these figures will reveal a small passage connecting the oil side of the diaphragm head cavity with the oil reservoir (See Figures 1 & 2). This passage is stopped off by a poppet that is held in place by a spring secured by a set screw. A plastic screw plug keeps the adjusting threads free of dirt.

In operation, the spring-loaded poppet is held against the seat in the housing until the pressure in the oil side of the diaphragm cavity exceeds the pressure for which the valve has been set. When this occurs, the poppet is forced off its seat, permitting the oil to flow from the diaphragm cavity through the mechanical passage to an opening (Figure 14) in the side of the oil reservoir. The resilient material of the poppet permits the relief valve to actuate without erosion of the poppet or seat surface.

Relief Valve Setting

The Pump must be at operational pressure and 95% capacity setting.

1. Remove the yellow plastic plug located at top of pump next to the oil fill hole.
2. Using a 3/16" hex. key (mRoy A), or a 5/16" hex. key (mRoy B) as required for the different models, turn the adjusting screw clockwise to increase cracking pressure until pump ceases to bypass through the relief valve at the desired working pressure. When relieving has stopped, adjust the screw clockwise up to one full turn beyond this point to set a reasonable buffer zone between operating pressure and relief pressure. To determine if relieving is taking place, insert your index finger into the oil reservoir opening and place it against the bypass opening (Figure 14) where the oil pulse from the relief valve can be determined.
3. Reinstall the plastic yellow plug

To set the relief valve to relief at a specified operating pressure.

1. Turn adjusting screw counter clockwise until screw top is just below surface of hole. This limits the discharge pressure of the pump.
2. Set micrometer to 95% and start the pump.
3. Slowly close a discharge valve downstream of a pressure gauge and watch pressure gauge closely. If pressure starts to exceed desired pressure or pressure gauge limit, quickly open valve. Unscrew adjusting screw a bit more but keep adjusting screw threads engaged.
4. With valve fully closed, the pressure displayed on pressure gauge located between pump and closed valve = pump internal relief valve set pressure. Slowly turn adjusting screw clockwise and notice pressure increases each turn. Continue adjusting to desired set pressure but do not exceed 15% higher than pump nameplate maximum pressure.

NOTE:

No moving parts are present in the oil reservoir in this location.

⚠ CAUTION WHEN OPERATING WITH RELIEF VALVES, ESPECIALLY ON PUMPS WITH LARGE PLUNGER SIZE, OIL MAY BE EJECTED AT HIGH VELOCITY FROM THE BYPASS PORT. NORMAL PRECAUTION SHOULD BE OBSERVED TO PREVENT THIS FROM SPLASHING THE SURROUNDING AREA.

NOTE:

This relief is intended primarily for pump protection in the event that the discharge or suction system is blocked while the pump is in operation. It is good practice to install a high-grade chemical type relief valve in the pump discharge line as close to the pump as possible, and always between the pump and any shut-off valve. Pipe the outlet of the system relief valve back to the suction tank, with the open end of the pipe visible at all times. In this way, relief valve leakage may be easily detected.

⚠ CAUTION FOR SAFETY REASONS, A CHECK VALVE IS RECOMMENDED FOR USE IN THE DISCHARGE LINE NEAR THE POINT WHERE THE LINE ENTERS A HIGH-PRESSURE PROCESS VESSEL.

3.3 OPERATION

The mRoy pump is designed for reliable, unassisted operation. During normal operation, a periodic check of the pump is recommended every 24 or 48 hours to visually confirm satisfactory operation:

1. Make sure the oil level in the reservoir is above the oil level mark.
2. Inspect the pump liquid end for indication of leakage or seepage.

If anything seems to be abnormal, refer to Section 4, Maintenance.

SECTION 4 - MAINTENANCE

4.1 SPARE PARTS

To avoid excessive downtime in the event of a parts malfunction, the spare parts shown below should be maintained in your stores to support each mRoy pump. For your convenience, these parts can be purchased either separately or packaged in the form of Routine Preventive Maintenance (RPM) Kits. RPM kit numbers are listed in Section 1, Figure 5.

Double quantities required for duplex pumps. Two diaphragms are required for double diaphragm simplex liquid ends; four are required for double diaphragm duplex liquid ends.

4.2 RPM KIT COMPONENTS

mRoy A & B Metallic Liquid End (Except plunger code "H")

- 1 Relief Valve Poppet
- 1 Suction Check Valve
- 1 Discharge Check Valve
- Diaphragm(s) of various sizes
- 2 Check Valve O-Rings
- 2 Split Ring
- 1 Ball (used on "V" high viscosity option only)

mRoy A & B Metallic Liquid End (Plunger code "H")

- 1 Suction Check Valve
- 1 Discharge Check Valve
- Diaphragm(s)
- 2 Check Valve O-Ring
- 2 Check Valve Backup Rings (Solid)
- 1 Head O-Ring

mRoy A Plastic Liquid End

- 1 Relief Valve Poppet
- 1 Suction Check Valve
- 1 Discharge Check Valve
- Diaphragm(s) of various sizes
- 2 Check Valve Seals
- 1 Square Ring
- 2 Tube Coupling Nut (used on tube connection checks only)

mRoy B Plastic Liquid End

- 1 Relief Valve Poppet
- 1 Suction Check Valve
- 1 Discharge Check Valve
- 1 Diaphragm
- 3 Check Valve O-rings

Parts Orders Must Include the Following Information:

1. Quantity required (in this manual)
2. Part number (in this manual)
3. Part description (in this manual)
4. Pump model no. (on pump nameplate)
5. Pump serial no. (on pump nameplate)

Always include the serial number, product code, and model number in all correspondence regarding the unit.

4.3 RETURNING UNITS TO THE FACTORY

Pumps will not be accepted for repair without a Return Material Authorization Form, available from the Aftermarket Department or at the website (www.miltonroy.com). Process liquid must be flushed from the pump liquid end, and oil should be drained from the pump housing before the pump is shipped. Label the unit clearly to indicate the liquid being pumped.

NOTE:

Federal law prohibits the handling of equipment that is not accompanied by an OSHA Safety Data Sheet (SDS). A complete SDS must be packed in the shipping crate with any pump returned to the factory. These safety precautions will aid the troubleshooting and repair procedure and preclude serious injury to repair personnel from hazardous residue in the pump liquid end.

All inquiries or parts orders should be addressed to your local Milton Roy representative. Representatives can be found on our website (www.miltonroy.com).

⚠ CAUTION BEFORE CARRYING OUT ANY SERVICING OPERATION ON THE METERING UNIT OR PIPES, DISCONNECT ELECTRICAL POWER FROM THE PUMP. TAKE THE NECESSARY STEPS TO ENSURE THAT ANY HARMFUL LIQUID IN THE PUMP OR PIPING SYSTEM CANNOT ESCAPE OR COME INTO CONTACT WITH PERSONNEL. SUITABLE PROTECTIVE EQUIPMENT MUST BE PROVIDED. CHECK THAT THERE IS NO PRESSURE BEFORE PROCEEDING WITH DISMANTLING.

4.4 ROUTINE MAINTENANCE

The mRoy pump is designed for reliable service with a minimum amount of maintenance required. Part of regular maintenance includes:

- Clean the pump regularly to prevent dust or liquid build-up.
- Check for leaks regularly.
- Check oil levels regularly to prevent pump damage or overheating.

Yearly replacement of check valves, diaphragm, and nylon relief valve poppet is recommended. For convenience, these parts are available in a Routine Preventative Maintenance (RPM) Kit from your local representative. RPM kit numbers are listed in Section 1, Figure 5.

4.5 SEMI ANNUAL OIL CHANGE

Use individual protection equipment.

Disconnect the pump's power supply. Ensure that the equipment cannot be started accidentally. Place a warning indication on the switch.

Wait for the pump to cool down before draining the oil.

Use a drip pan to catch drained oil.

The oil in the main housing should be drained twice a year, using the drain plug provided, and new oil installed. This can usually be scheduled to coincide with the change from winter to summer grade oil and vice versa. Refer to "Pump Lubricants" in Section 2, Installation, for information on recommended oil and oil capacity.

NOTE: When adding oil, pour in a thin, slow stream to avoid overflow, then check level.

4.6 CHECK VALVE CARTRIDGES

Use individual protection equipment.

We recommend when possible to install a drain/flush valve at the pump suction and discharge to facilitate check valve routine maintenance. See fig. 12.

Close pump suction and discharge valves. Drain pipes between pump and isolation valves. Flush through pump from suction side as process fluid remains trapped inside liquid end between check valves with compatible liquid. See figure 12. Water is most frequently used but not with sulfuric acid. Flushing through pump ensures check valves and pump liquid end are safe to handle.

Milton Roy Company recommends that the check valves are replaced on an annual basis. If highly corrosive material (acids, slurries, etc.) is being pumped, some applications may require more frequent replacement.

In general, poor or reduced pump performance indicates that the check valves need to be replaced (refer to Section 5, Troubleshooting).

Complete instructions for replacing worn check valves are given in the "Corrective Maintenance" section.

The mRoy check valves are complete assemblies manufactured at the factory and should not be disassembled in the field.

To determine if the check valves need replacement, with the pump off and pressure removed from system unscrew the check valve from the liquid end and look through the hole in the check valve seat. The ball should appear perfectly round and free of pits, mars, or scratches. If the ball and/or seat is excessively damaged, the replacement schedule should be shortened accordingly. If the ball and seat are both in good condition, the replacement schedule can be lengthened.

SECTION 4 - MAINTENANCE

4.7 DIAPHRAGM(S)

1. Use individual protection equipment.
2. Use proper tools.
3. Disconnect the pump's power supply. Ensure that the equipment cannot be started accidentally. Place a warning indication on the switch.
4. Use a drip pan for chemical products when dismantling the liquid end.
5. Close pump suction and discharge valves. Drain pipes between pump and isolation valves. Flush through pump from suction side as process fluid remains trapped inside liquid end between check valves with compatible liquid. See figure 12. Water is most frequently used but not with sulfuric acid. Flushing through pump ensures check valves and pump liquid end are safe to handle.

Disconnect the liquid end from the pump. The mRoy PTFE diaphragm is extremely durable and often lasts for many years. As a preventative measure, Milton Roy recommends that the mRoy diaphragm be replaced yearly to coincide with check valve replacement. Also, whenever the head is removed freeing the diaphragm, the diaphragm must be replaced.

NOTE: Sealing grooves created when tightening head bolts creates one time seal.

Refer to the instructions in the "Corrective Maintenance" section for diaphragm replacement.

4.8 RELIEF VALVE POPPET

Milton Roy recommends that the nylon relief valve poppet be replaced yearly during preventative maintenance. This can usually be timed to coincide with check valve replacement. Refer to the instructions in the "Corrective Maintenance" section.

4.9 CORRECTIVE MAINTENANCE

- Use individual protection equipment.

- Use proper tools.

- Disconnect the pump's power supply. Ensure that the equipment cannot be started accidentally. Place a warning indication on the switch.

- Use a drip pan for chemical products when

dismantling the liquid end.

- Isolate the pumped product line, depressurize the line using the priming valve.
- Wait for the pump to cool down before doing corrective maintenance.
- Use a drip pan to catch drained oil.

4.9.1 CHECK VALVE CARTRIDGE REPLACEMENT

With the exception of the mRoy A and L plastic versions, mRoy suction and discharge check valve cartridges are precision machined and assembled at the factory. Do not attempt to disassemble these cartridges. If they become inoperative, flush them with Safety Solvent, wash them with warm detergent and blow them out with compressed air to remove any foreign matter. (Refer step 4, from topic section 4.9.1.1). If this treatment does not eliminate the trouble, the cartridge assembly should be replaced.

mRoy A plastic suction and discharge check valve cartridges may be disassembled for cleaning or parts replacement.

4.9.1.1 METALLIC LIQUID ENDS (FIG. 16, 17, 19 & 24)

DISASSEMBLY

1. The check valve cartridge assemblies use a SAE straight thread with an O-ring seal to facilitate port alignment with the connecting pipes. To remove the cartridge from the liquid end, first loosen the lock nut (520) one or two threads then unscrew the cartridge.
2. Remove and discard the O-ring (540) and spiral back-up ring (530).
3. On model MRA High Viscosity pumps only, the ball in the suction port of the liquid end is not sealed inside the suction check valve. This ball should fall out easily when the suction check valve is removed.
4. Carefully clean any parts to be reused. If any chemicals are used in the cleaning process, ensure that they are approved with the process liquid.

REASSEMBLY

1. To install the cartridge, position the lock nut (520) toward the shoulder of the cartridge so that the recess on the face of the lock nut is adjacent to the O-ring (540) land (thread undercut) in the cartridge.
2. Make certain the spiral back-up ring (530) is coiled in a counterclockwise helix (this is opposite the direction normally employed by suppliers of these rings. Fit the spiral back-up ring (530) in the lock nut (520) recess. Push it firmly down in the recess as completely as possible.
3. Install a new O-ring (540) against the spiral back-up ring (530).

NOTE: To assure a tight, leak free seal, new O-rings and spiral back-up rings should be used each time the check valves are disassembled.

4. On model mRoy "V" option pumps only (Figure 16), the separate ball (570) needs to be balanced on the end of the suction check valve cartridge so that it will be held in place in the suction port by the check valve when it is screwed in.
5. Screw the cartridge assembly into the liquid end until the O-ring band is approximately level with the top of the spot face in the liquid end, then screw it in one (1) additional turn plus a partial turn as required to align the pipe thread port with connecting pipe.

▲ CAUTION SUCTION AND CHECK VALVE CARTRIDGES ARE NOT IDENTICAL.

BE SURE THAT THE CORRECT CARTRIDGE IS BEING SCREWED INTO THE PROPER PORT. (DISCHARGE CARTRIDGES HAVE HEXAGONAL CAP ON THE TOP; SUCTION CARTRIDGES DO NOT.) IF CHECK VALVE CARTRIDGES ARE INSTALLED INTO THE WRONG PORT, ONE OF THE FOLLOWING WILL OCCUR: (A) IMMEDIATE SEVERE DAMAGE TO PUMP MECHANISM, (B) NO PUMPING, (C) REVERSE PUMPING ACTION (FROM DISCHARGE LINE INTO SUCTION LINE).

6. After completing pipe connection, tighten lock nut (520) securely against spot face so that O-ring
7. (540) is trapped in chamfer of liquid end thread. Make sure that the spiral back-up ring (530) is completely contained in its recess and not extending to the outside.

4.9.1.2 MROY A PLASTIC, CURRENT DESIGN (FIG. 16)

DISASSEMBLY

1. Unscrew the check valve assembly from the pump liquid end.
2. Both the suction and discharge check valves may be disassembled in the same way. While carefully holding the body use a 5/16" rod to push out the internal parts. Do not damage the sealing face (opposite the threaded end) on the valve body. It is essential to reinstall the ball guides and ball stop in the proper direction, so take notes during disassembly and follow the assembly drawing.
3. Carefully clean any parts to be reused. If any chemicals are used in the cleaning process, ensure that they are approved with the process liquid.

REASSEMBLY

NOTE:

To assure a tight, leak free seal, new seals and O-rings should be used each time the check valves are disassembled.

1. Lightly coat the O-rings on the ball guides with mineral oil or other food grade lubricant (Refer step 3, from topic section 4.9.1.2). It is essential to reinstall the ball guides and ball stop in the proper direction. Remember the ball always lifts off the seat in the direction of liquid flow. The ball stop is used to retain the last ball check on the suction cartridge.
2. Remove the old valve-to-head seal (435) from the head and install a new seal. A fracture of the diaphragm head may result from installing the check valve against two seals or excessive tightening. The groove in the seal is to be oriented against the check valve body.

SECTION 4 - MAINTENANCE

4.9.1.3 MROY B PLASTIC LIQUID END (FIG. 24)

DISASSEMBLY

1. The mRoy B plastic check valves are held in place by two long bolts (521) that extend through the diaphragm head. Unscrew the nuts (519) to remove the check valves from the liquid end. Use caution when doing so, as the suction check valve and compression plate (518) will fall off when the bolt is removed.
2. Remove and discard the check valve O-rings (540).
3. Carefully clean any parts to be reused. If any chemicals are used in the cleaning process, ensure that they are approved with the process liquid.

REASSEMBLY

NOTE: To assure a tight, leak free seal, new O-rings should be used each time the check valves are disassembled.

1. The discharge check valve consists of two separate pieces that are shipped held together with masking tape. Leaving the masking tape in place during assembly will make the process easier. These parts already have an O-ring in place between them.
2. Drop a new O-ring (540) into position in the discharge port of the liquid end. Slip the entire discharge cartridge (still held together with masking tape) into the discharge port (only one end will fit in).
3. Screw a nut (521) two or three turns (just enough to hold) on one end of each through bolt. Slide the compression plate over the discharge cartridge (517). Slip the bolts (521) through the holes in the compression plate and diaphragm head so that they fall through and hang out the bottom.
4. Fit a new O-ring (540) into position on the top of the suction cartridge.
5. Insert the suction cartridge and O-ring up into the suction port of the liquid end. Position the other compression plate (518) under the suction check valve by sliding it up on the bolts. Screw on the two remaining nuts (519). The suction check valve should now be held in place in the liquid end. Tighten the nuts on the through bolts firmly. Do not over-tighten or plastic fittings may be damaged.

4.9.2 RELIEF VALVE POPPET REPLACEMENT (FIG. 15)

If the pump is allowed to operate for long periods with the relief valve relieving pressure, there is a possibility that the poppet will wear, causing erratic flow and discharge pressure. If this occurs, the relief valve poppet should be replaced. Even if excessive wear has not occurred, it is still recommended that the nylon poppet be replaced on a yearly basis.

DISASSEMBLY

1. Unscrew and remove the relief valve screw plug (1350).
2. Unscrew and remove the relief valve adjustment screw (50).
3. Remove the relief valve spring (40). A pair of tweezers may be required to remove the spring from the relief valve port.
4. Remove the relief valve poppet (30) with a tweezer or by “jogging” the motor, causing oil to flow up through the relief port to float the poppet up and out of the threaded hole.

REASSEMBLY

1. Temporarily secure a new poppet (30) into the end of the spring (40) with thick grease. Drop this assembly into place in the relief valve port.
2. Install the relief valve adjustment screw (50) until the spring (40) is lightly compressed. Follow the instructions for resetting the relief valve given in Section 3, Operation.

4.9.3 DIAPHRAGM REPLACEMENT (FIG. 16-26)

Sealing grooves are created in mRoy PTFE diaphragms when tightening head bolts to specified torque. These grooves prevent leaks when properly torqued. If the pump head is removed for inspection, the diaphragm must be replaced. The mRoy A & B models have different assembly depending on whether they have leak detection. Be sure to refer to the appropriate Figure (16-28) when replacing the diaphragm(s).

DISASSEMBLY

1. Remove the eight (8) bolts (350 or 355) from the diaphragm head (330), depending on the model.
2. Remove the diaphragm (290).
3. Remove the contour plate(s) (282).
4. If servicing a pump with a square ring (260), remove and discard the square ring.
5. If servicing a double diaphragm style pump, remove the intermediate chamber and square head plated pipe.
6. Carefully clean any parts to be reused. If any chemicals are used in the cleaning process, ensure that they are approved with the process liquid and hydraulic oil.

REASSEMBLY

1. Place pump on its side with diaphragm cavity facing up.
2. Install contour plate(s) (282) into position in the housing and/or diaphragm head (330), as appropriate.
3. Carefully center diaphragm (290) in the shallow recess in the housing.
4. If servicing a double diaphragm style pump, position the intermediate chamber over the diaphragm. Fit a second new square ring (260) (if required) into position in the recessed square ring groove. Carefully center the second diaphragm (290) in the shallow recess in the intermediate ring.
5. Retain diaphragm with thin, flat blade 1/2" to 1"
6. (12.7 mm to 25.4) mm wide.
7. Carefully position the diaphragm head and contour plate (this diaphragm head side contour plate is not used on some models) in place, aligning bolts holes.

Remove blade and torque bolts as follows (See Figure 13):

- a. mRoy Model A Metal Heads (except plunger "H"): 265–275 in. lbs. (30-31 N-m) bolting torque (grade 5 or stronger bolts)

- b. mRoy Model A – Plunger "H": 340-350 in lbs. (38-39.5 N-m) bolting torque
- c. mRoy Model A Plastic Heads: 60–70 in. lbs. (7-8 N-m) bolting torque
- d. mRoy Model B Metal Heads: 340-360 in lbs. (38-41 N-m) bolting torque
- e. mRoy Model B Plastic Heads: 75–85 in. lbs. (8.5-9.6 N-m) bolting torque tie down nuts 25 in. lbs. (3 N-m).

Procedures for complete disassembly of the mRoy pump are listed below. Some steps can be omitted depending on which part is replaced.

4.9.4 MOTOR AND WORM REPLACEMENT (FIG. 14 & 15)

Be certain that the motor is disconnected before it is removed in order to replace or inspect the motor or the gears.

DISASSEMBLY

1. Remove oil drain plug and drain oil.
2. Remove the screws that attach the motor to the pump.
3. On "C" (close coupled) units, remove motor; the gear shaft may come out as well. If the motor separates from the worm shaft (640), use care not to lose the shaft key and coil spring.
4. Remove worm assembly (120).
5. On units with API motor mount adapters, removal of the motor and adapter together will also lift the worm gear shaft from the pump.

REASSEMBLY

1. Reinstall by reversing steps 1 through 5 or follow the "motor conversion" directions.

Note: Apply sealant all around the edge and around the 4 bolt holes of the face of the motor mount as shown. Before you assemble the motor mount on the pump make sure you have sealant all around the flange and covering the 4 holes.

SECTION 4 - MAINTENANCE

4.9.5 CONTROL SPOOL O-RING REPLACEMENT (FIG. 14, 16 & 17)

Occasionally, the control spool O-rings may need to be replaced. Replacement is usually indicated if pump delivers less rated flow than expected.

DISASSEMBLY

1. Remove E-ring (220).
2. Unscrew and remove capacity control knob (210).
3. Remove screw (180) in threaded sleeve (170) (capacity control).
4. Remove diaphragm head (330), diaphragm
5. (290), contour plate (280 & 285), and motor and motor mount.
6. Remove control spool (160) from bore.
7. For mRoy A pumps, fabricate a tool by inserting a 3/16" diameter x 4-in. long soft plastic (e.g. Nylon) solid rod into the 3/16" hole and shaping the end with a 7/16" reamer inserted into the control spool bore. For the mRoy B pumps, a tool is not required.

CAUTION

CAREFUL USE OF REAMER IS HIGHLY RECOMMENDED AS DAMAGE MAY OCCUR TO THE SURFACE OF THE BORE. A TOOL, PART NUMBER O-RING TOOL CAN BE PURCHASED FROM MILTON ROY.

REASSEMBLY

1. Place new O-rings (150) on control spool (160) and coat O-rings liberally with grease to hold them in place.
2. Place O-ring tool (notch facing up to guide O-ring across intersecting passage), into 3/16 hole at 12:00 o'clock position behind the contour plate.
3. Push control spool and O-rings into bore carefully, using O-ring tool to guide O-ring across intersecting passage. This is being done to prevent damage to O-rings. Finally, guide control piston into center of control spool, motor side.

4.9.6 WORM GEAR REPLACEMENT (FIG. 14) DISASSEMBLY

1. Remove motor assembly, following instructions shown in "Motor and Worm Replacement" section.
2. Remove two screws (250), linkage arm (240), and control plunger (230).
3. Use arbor press or hammer and brass punch to remove the gear shaft from the gear.
4. Lift worm gear, connecting rod, and plunger assembly up and out of pump housing.

REASSEMBLY

1. Once the gear along with plunger and connecting rod assembly is in the housing you are ready to slide the gear shaft back into the housing.
2. When installing gear shaft into the pump housing you will need to Loctite the ends of the shaft to prevent oil leaking.
3. Make sure the sealing grooves are clean. by wiping down with isopropyl 70/30 alcohol and allowing it to evaporate for 10 sec.
4. Loctite primer must be applied completely around the gear shaft O.D. and the pump housing I.D for the gear shaft.
5. While the shaft is hanging out of the hole, apply Loctite 242 to the O.D. of the exposed shaft of side A and on the other side of the housing apply Loctite to the I.D. of the pump housing gear shaft hole on side B. Then push the shaft thru exposing side B shaft, then you can repeat the Loctite step on side B.
6. Make sure the shaft is flush or below flush on both sides of the housing.
7. Note: Loctite has a 45-minute working time and 24 hours for a full cure. Wipe off any excess Loctite.
8. Complete Reassembly by reversing steps 1 & 2.

4.9.7 CONNECTING ROD AND PLUNGER REPLACEMENT (FIG. 14)

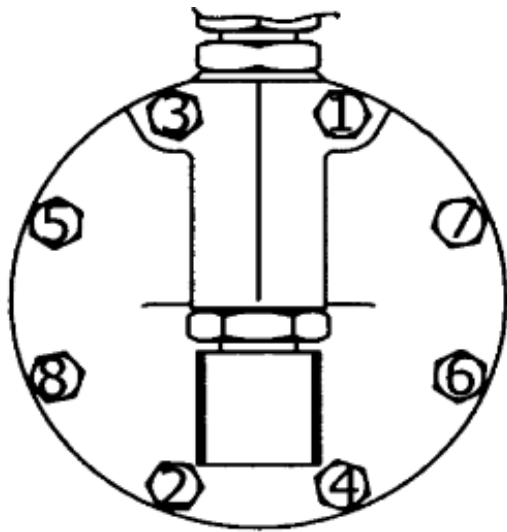
DISASSEMBLY

1. Lift connecting rod (100) up and back to disengage plunger (90) from bore.
2. Use arbor press or hammer and brass punch to remove wrist pin (110) from connecting rod
3. (100) and plunger (90).
4. To assure proper installation, note position of oil groove for wrist pin (110) and oil groove for worm gear (120) with respect to connecting rod (100) and plunger (90). Groove should be located at bottom of bore.

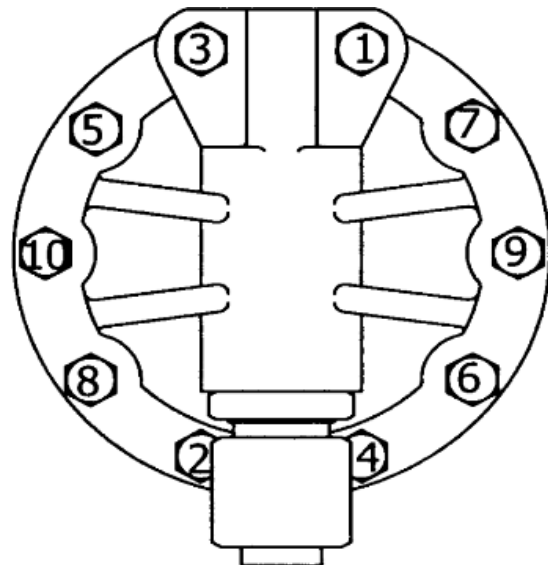
REASSEMBLY

1. Reverse steps 1 through 3 above. Be sure to properly align oil groove to its original position, as noted in step 3.

4.9.8 HEAD BOLT TORQUE PATTERN



mRoy A- 8 Bolt Pattern



mRoy B- 10 Bolt Pattern

FIGURE 13. DIAPHRAGM HEAD BOLT TORQUE PATTERN

SECTION 5 - TROUBLESHOOTING GUIDE



SYMPTOMS	REMEDIES
<p>Pump motor won't operate.</p>	<p>CAUTION: Electrical work is to be done by a person with the appropriate competence / training and electrical clearance license. The person doing the wiring shall wear proper Personal Protection Equipment.</p> <p>The electrical work is to be done with the power supply off and locked. Watch for and remove any residual energies before doing any electrical work.</p> <ul style="list-style-type: none"> • No power. Supply correct power in accordance with motor nameplate. • Blown fuse. Check for short circuit or overload. • Open thermal overload device in starter. Reset overload. • Broken wire. Locate and repair. • Low voltage. Check for too thin wiring. • Low liquid level (where low-level cutoff is used). Fill tank. • Oil is frozen in pump. Thaw out. • Bad motor. Replace motor. <p>ATTENTION: After putting the pump in service, during the first hour, check in the cables and electric circuit for any heat increases and also listen for any suspicious mechanical noises.</p>
<p>Pump doesn't deliver rated capacity.</p>	<ul style="list-style-type: none"> • Starved suction. Replace suction piping with larger size or increase suction head. • Leaky suction piping. Repair or replace defective piping. • Excessive suction lift. Rearrange equipment location to reduce suction lift. • Liquid is too close to boiling point. Lower temperature or increase suction pressure. • Air in pump head. Bleed system. • Air or gas trapped in pump hydraulic oil. Decrease capacity to 20% for 5 mins. Then increase to 100% for 5 mins. • Worn or dirty valves or seats. Clean or replace cartridges. • Viscosity of liquid too high (cps). Reduce viscosity by heating or other means, or increase size of suction piping, or increase suction pressure. • Insoluble materials; crystallization of liquid; settling of solids. Limit solution strength to proper value. Flush and clean solution tank periodically. Suction connection should be 2" to 4" above bottom of solution tank. • Low discharge pressure. A minimum discharge pressure is required to ensure proper capacity control (see Discharge Piping, 2.1 Section II.) • Internal relief valve being actuated. Refer to Section 3.2. • Capacity adjustment set above 100% capacity mark. Reposition adjustment knob to 100% or less.

SECTION 5 - TROUBLESHOOTING GUIDE

SYMPTOMS	REMEDIES
Pump delivers erratically.	<ul style="list-style-type: none"> • Leaky suction line. Repair or replace piping. • Worn or dirty valves or seats. Clean or replace cartridges. • Excessive excursion of ball valves from seats (indicated by ball chatter). Replace cartridges. • Insufficient suction pressure. Increase suction pressure by <ul style="list-style-type: none"> • raising tank level or pressurizing suction tank. • Liquid is too close to boiling point. Reduce temperature or raise suction pressure. • Leaky system relief valve. Repair or replace relief valve.
Motor overheats thermal overload switches.	<ul style="list-style-type: none"> • Power supply does not match motor characteristics. Check power supply against motor nameplate data. • Overload caused by operating pump above its discharge pressure. Check operating pressure against pump manufacturer's data plate max. rating and correct the cause of the pressure abnormality. • Starved pump suction with internal relief valve over tightened.
<p>Noisy operation of pump liquid end.</p> <p>Noisy operating in drive casing (pounding noise at high discharge pressure).</p>	<ul style="list-style-type: none"> • Pump valves must move to open and close, and they will make a clicking noise as they operate. These noises are <ul style="list-style-type: none"> • sometimes amplified by natural resonances in the piping system. • They are usually indications of normal valve functioning. • Fluid compressibility causes reversal load on gears at end of pressure stroke. Not considered detrimental. No action needed. • Pump internal relief valve actuating, caused by excessive suction lift conditions. Lower pump or raise level of liquid. • Pump internal relief valve actuating, caused by insufficient suction pressure. Correct poor suction condition. • Pump internal relief valve actuating, caused by clogged or partially blocked filter or strainer in suction line. Clean strainer. • Pump internal relief valve actuating, caused by clogged or fouled suction or discharge check valves. Clean or replace. • Pump internal relief valve actuating, caused by blocked discharge line. Remove blockage.
<p>Improper oil level in reservoir increases and overflows.</p> <p>Pump delivery is not adjustable.</p> <p>Pump does not develop required pressure.</p>	<ul style="list-style-type: none"> • Flexible diaphragm punctured by foreign material. Replace diaphragm. • System pressure too low. Install a back pressure valve in the discharge line. • Refer to symptom marked with an * or check to see if system pressure exceeds rated capacity on data plate. • O-rings on control spool are nicked. Replace the O-rings. (Note: You must use a special tool. See section on control spool disassembly.) • Carefully review causes and remedies for the second and third symptoms listed.

SECTION 6 - PARTS



6.1 GENERAL

This section gives information regarding replaceable components.

6.2 ILLUSTRATED PARTS LIST

1. Figure and Item Number Column

- a) The item numbers shown in the detailed parts list correspond to the item numbers appearing on the exploded view illustration. To find an unknown part number, locate the part on the illustration and note the item number. Look for the item number on the detailed parts list. The part number is on the same line. A dash (-) precedes non-illustrated item numbers.

2. Description Column

- a) The name of the item is in the description column.

3. Part Number Column

- a) The part number is listed in the part number column.

4. Material/SPM Column

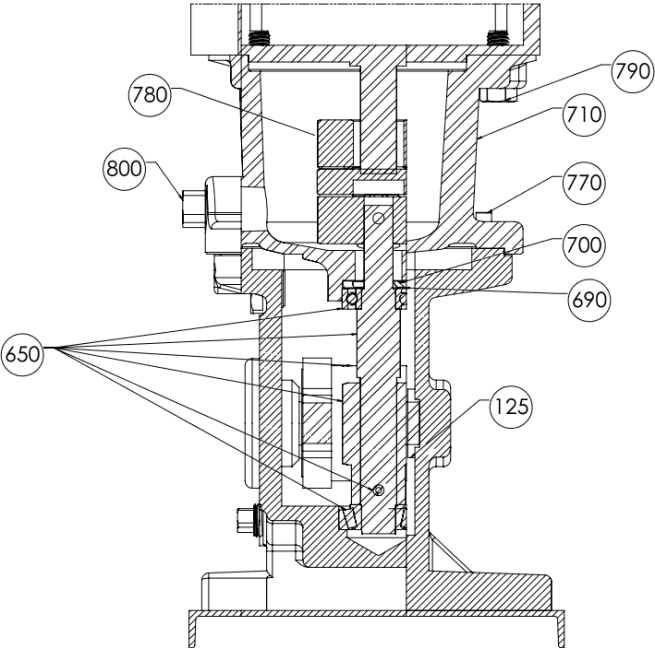
- a) The material used to manufacture the part is listed in the material/SPM column.
- b) The strokes per minute are listed for all worm and shaft assemblies in the material/SPM column.

5. Quantity Column

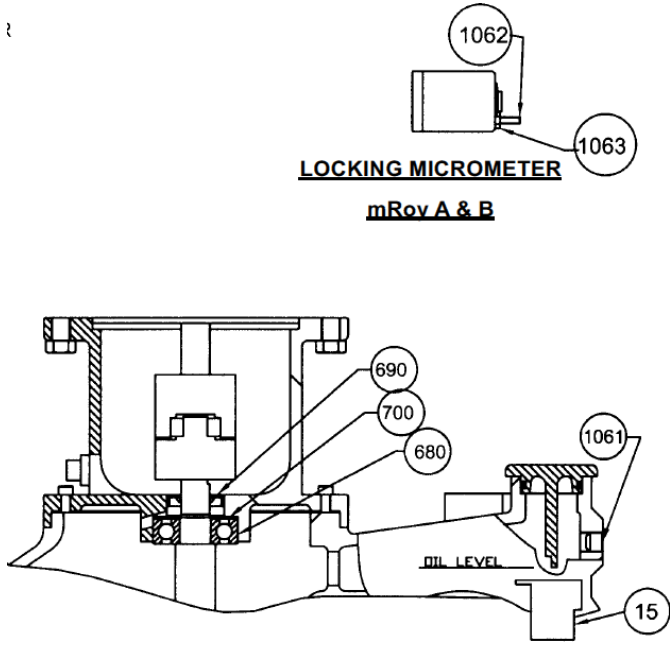
- a) The numbers appearing in the quantity column are the total quantity of the listed part required in its immediate assembly.

Refer to table numbers (6.3 to 6.23) for the above Parts List information.

SECTION 6 - PARTS



API FLANGE MOTOR MOUNT

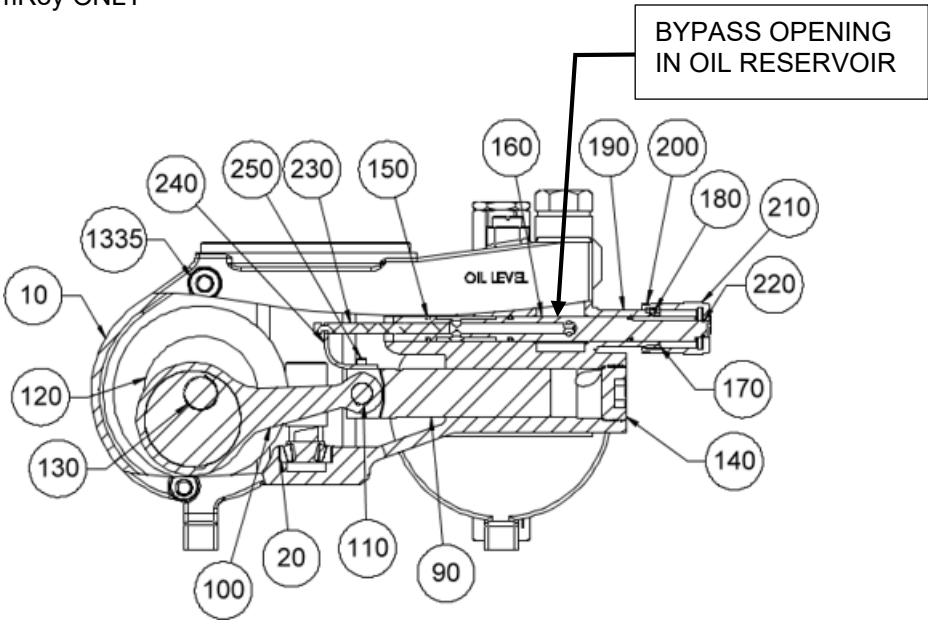


mRoy DRIVE, SIDE VIEW

BAFFLE FOR DUPLEX

NOTES:

ITEMS 650 SOLD AS AN ASSEMBLY
 ITEM 125 mRoy ONLY



DRIVE, SIDE VIEW

**FIGURE 14. COMMON PARTS - MROY A & B SIDE VIEW AND API MOTOR MOUNT
 (DWG(S) 99920090011 AND 99920090010)**

SECTION 6 - PARTS

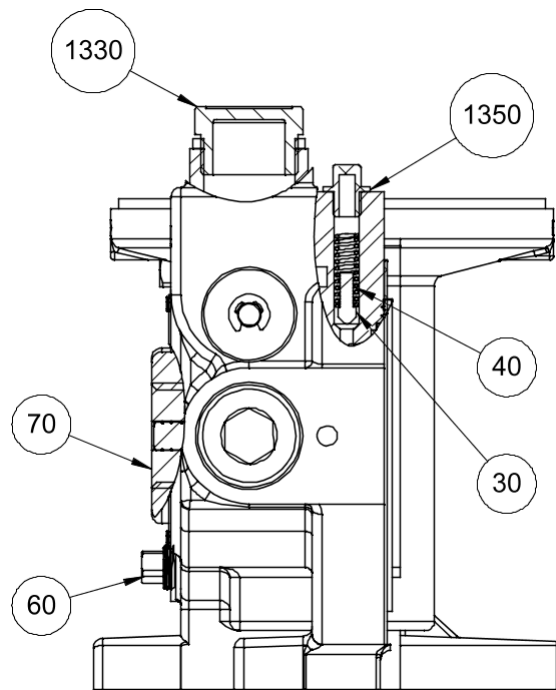
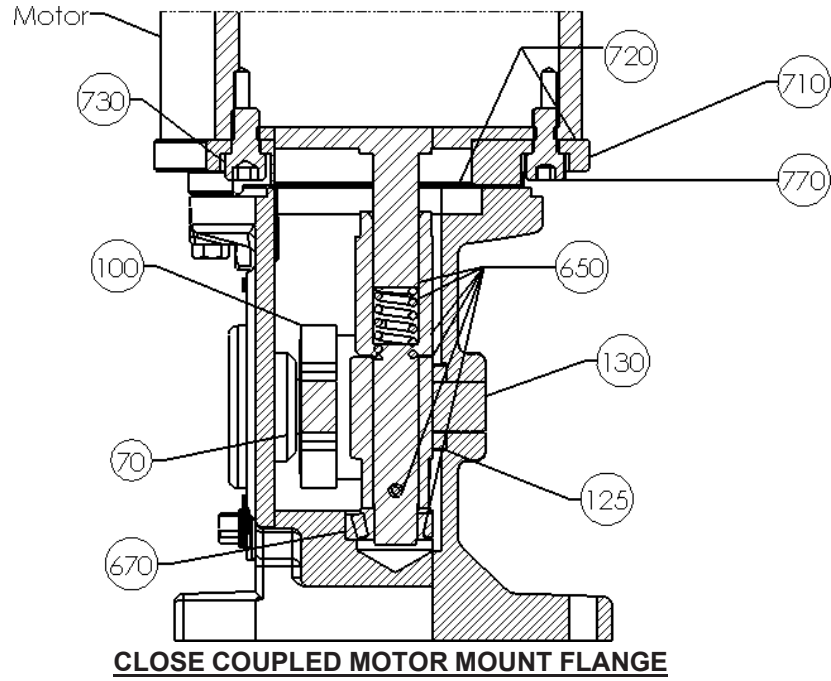
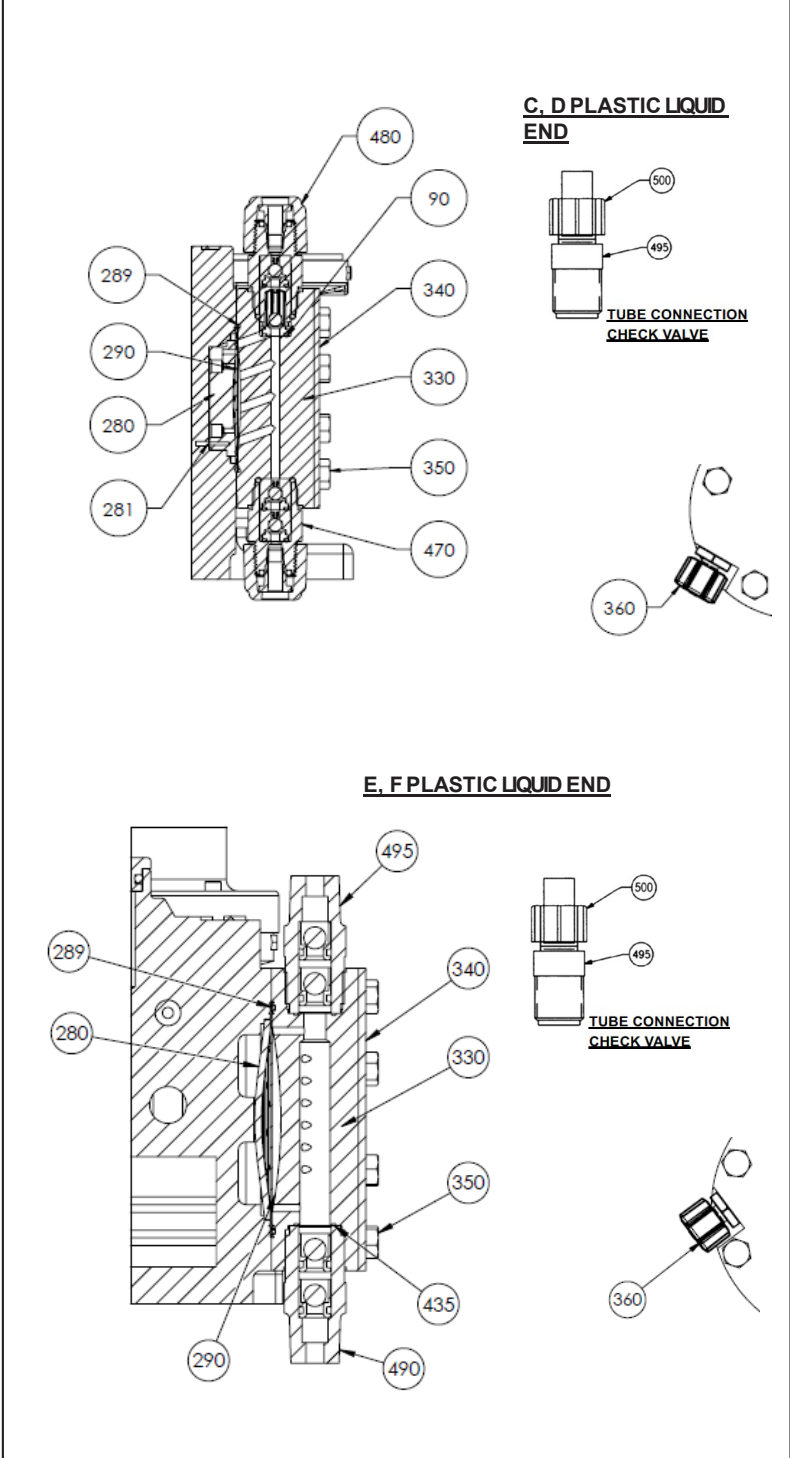
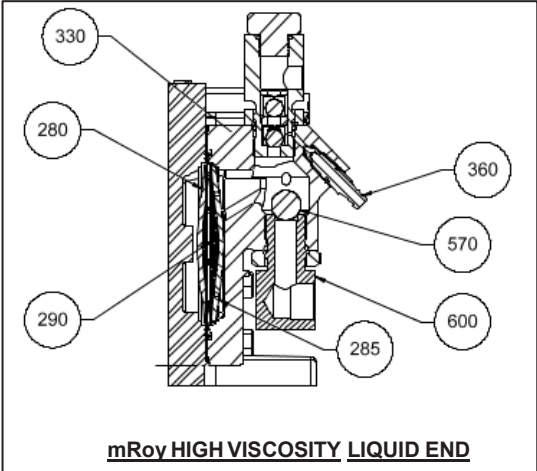


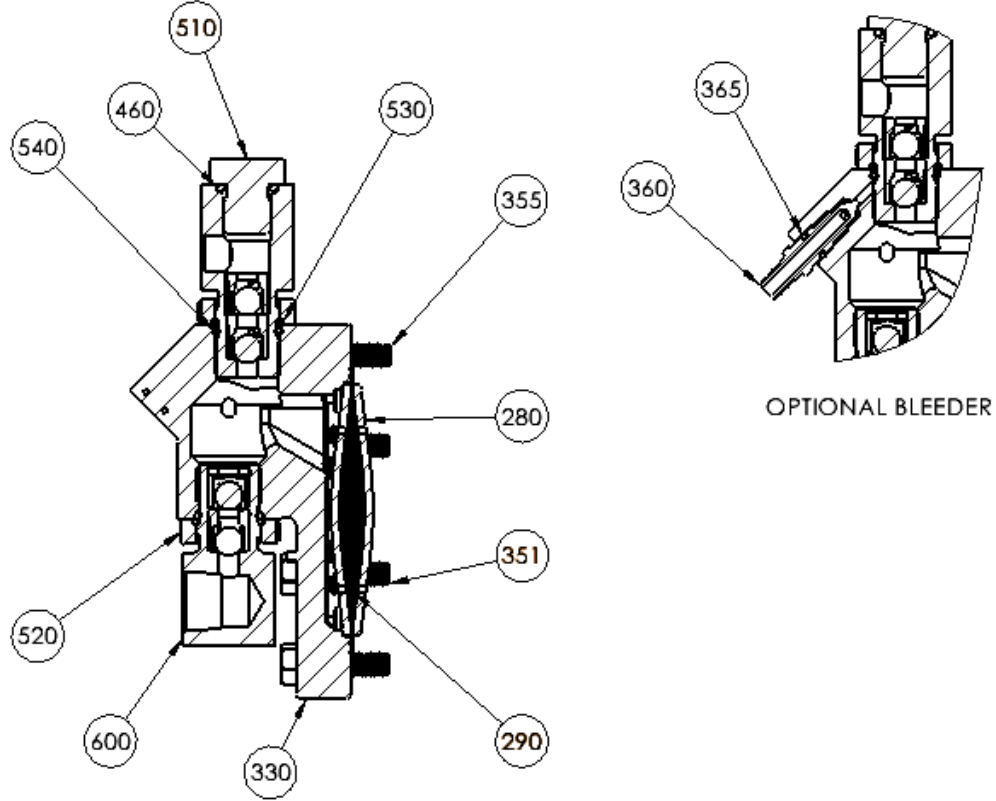
FIGURE 15. COMMON PARTS - MROY A & B END VIEW AND MROY A CLOSE COUPLED MOTOR MOUNT (DWG(S) 99920090011 AND 99920090009)

SECTION 6 - PARTS

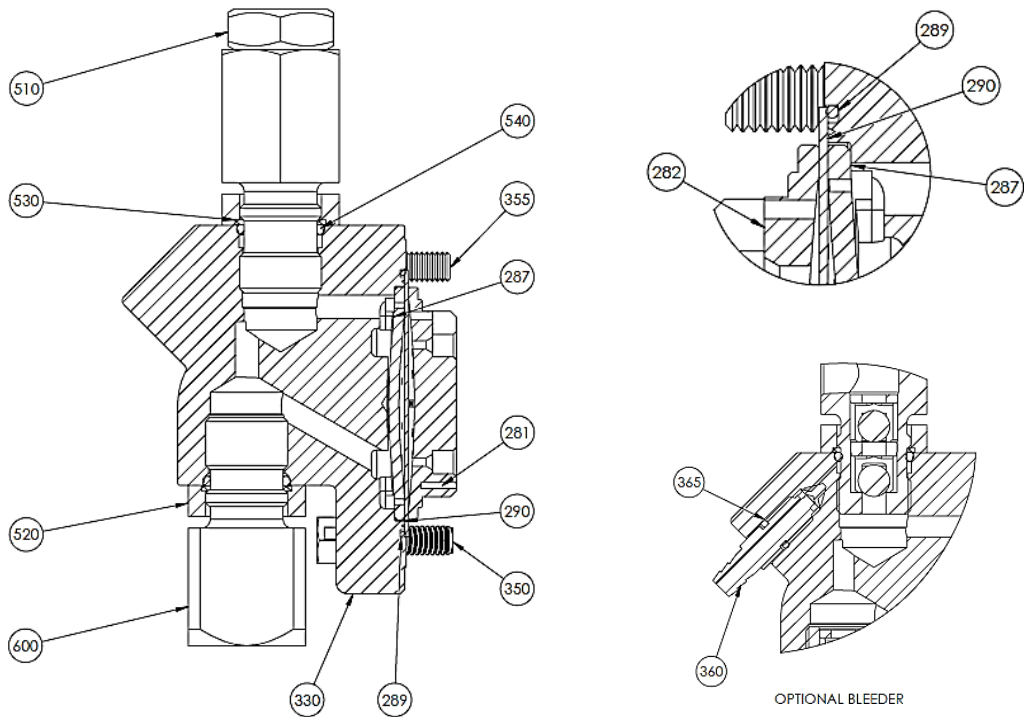


**FIGURE 16. MROY A HIGH VISCOSITY & PLASTIC LIQUID ENDS
(DWG 99920090001 & 99920090002)**

SECTION 6 - PARTS



mRoy A: E, F PLUNGER LIQUID ENDS (DWG 9992004017)



mRoy A: C, D PLUNGER LIQUID END (DWG 9994027123)

FIGURE 17. MROY A METALLIC LIQUID ENDS

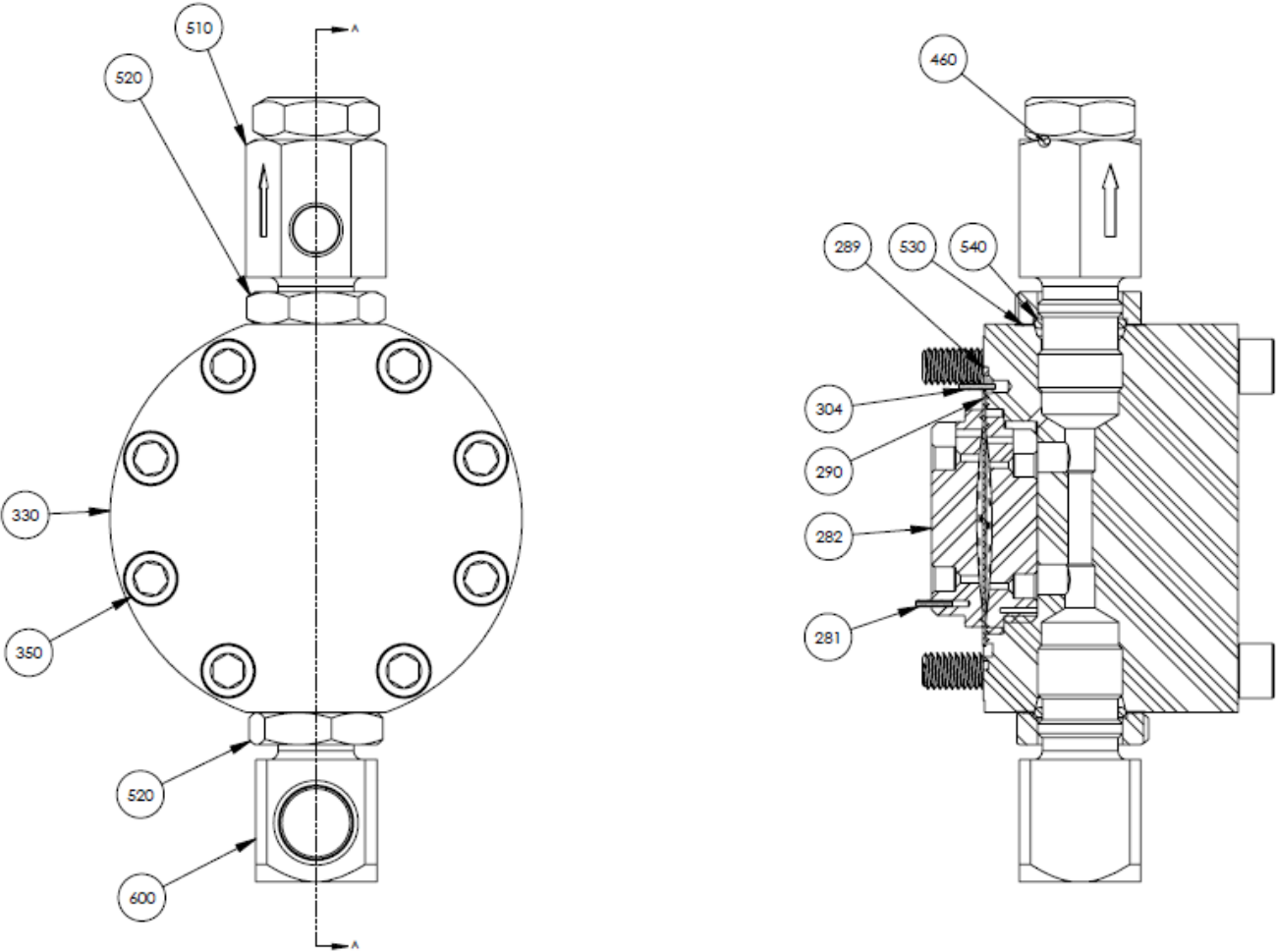
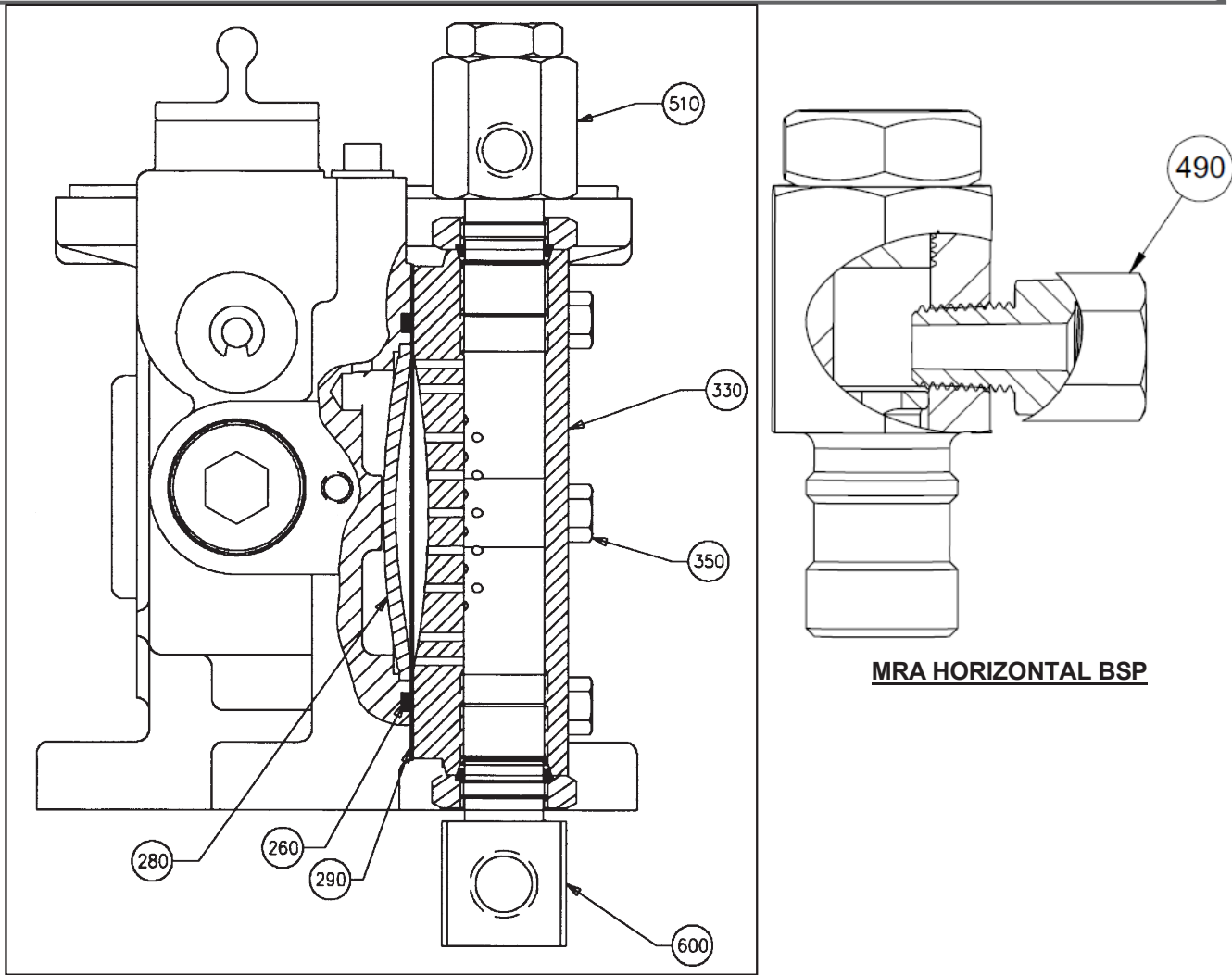


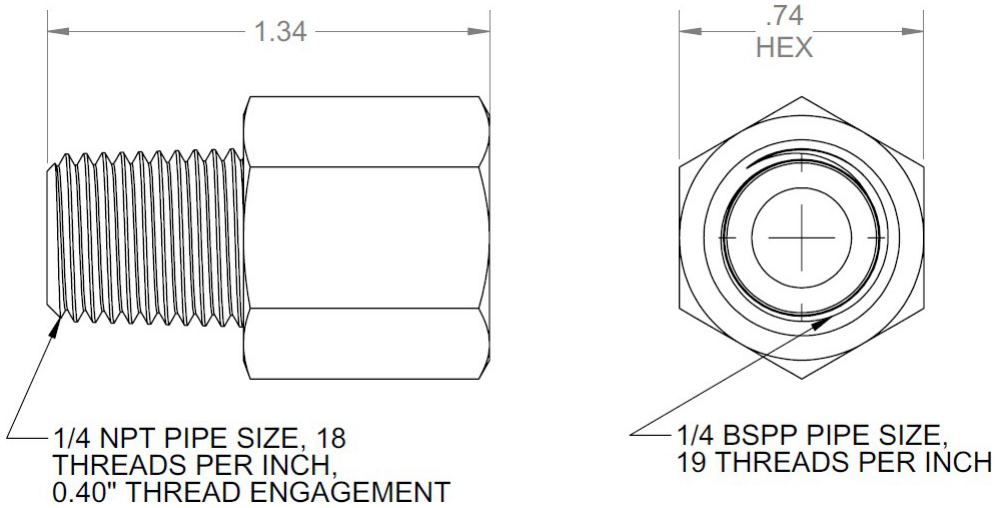
FIGURE 18. MROY A PLUNGER "H" 316SS LIQUID END
(DWG 9994027393)

SECTION 6 - PARTS



BAR STOCK LIQUID END

MRA HORIZONTAL BSP



1/4 NPT TO BSP ADAPTER

**FIGURE 19. MROY A BAR STOCK LIQUID END AND BSP CHECK VALVE OPTION
(DWG 99920090020 and 54626)**

DOUBLE DIAPHRAGM LIQUID END

Drawings Applicable to mRoy A - C, D Liquid Ends

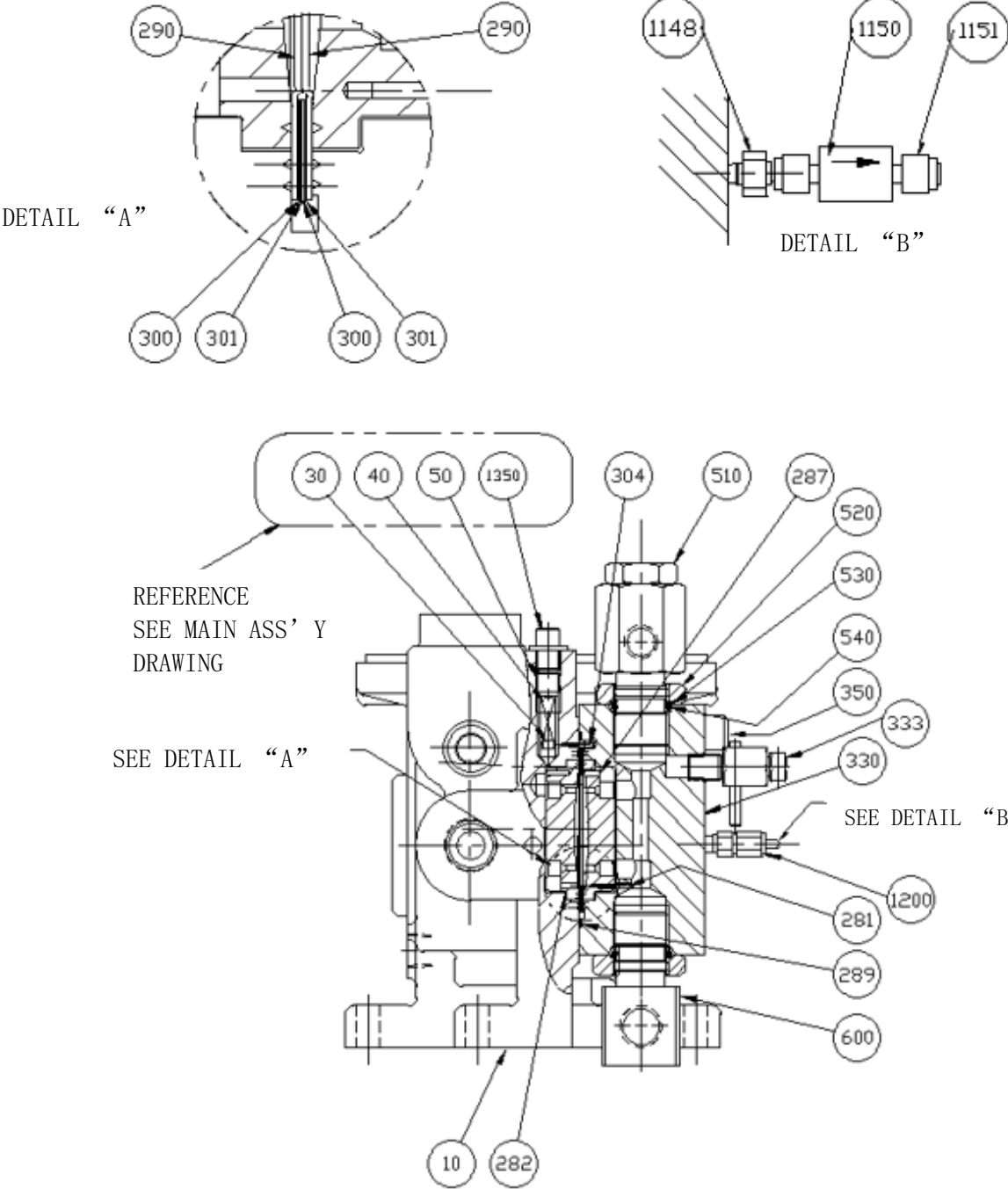
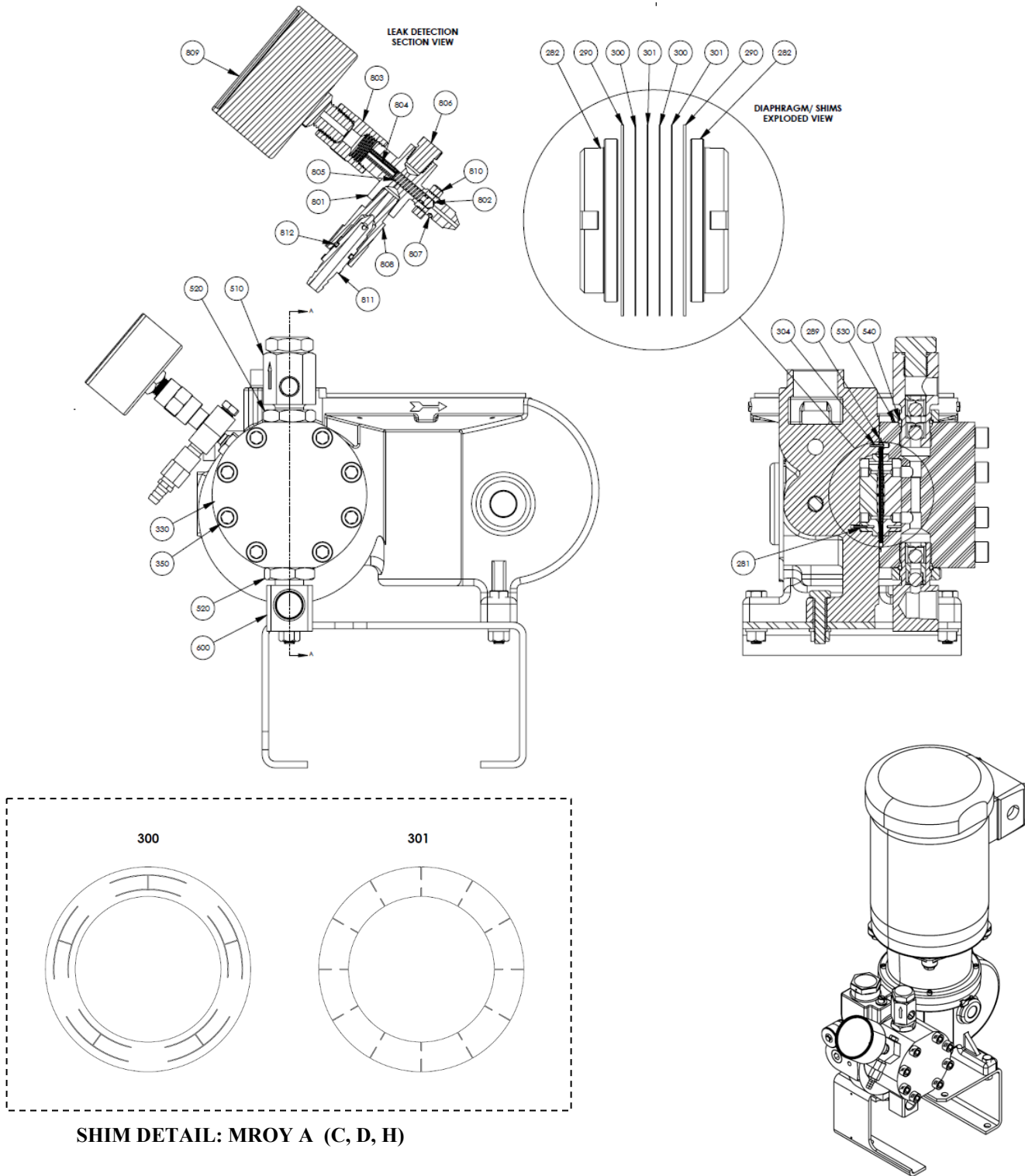


FIGURE 20. MROY A DOUBLE DIAPHRAGM AND LEAK DETECTION

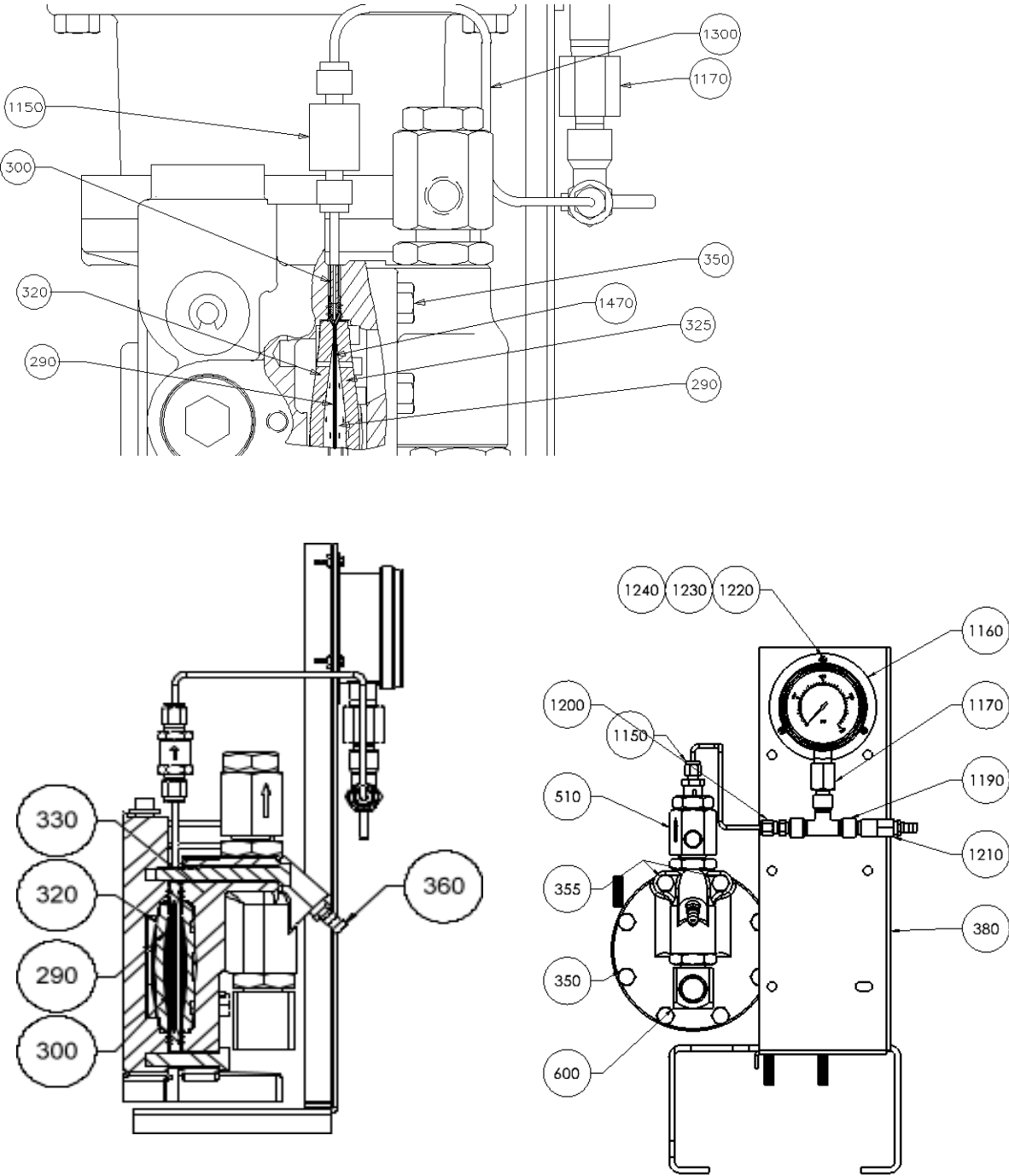
SECTION 6 - PARTS



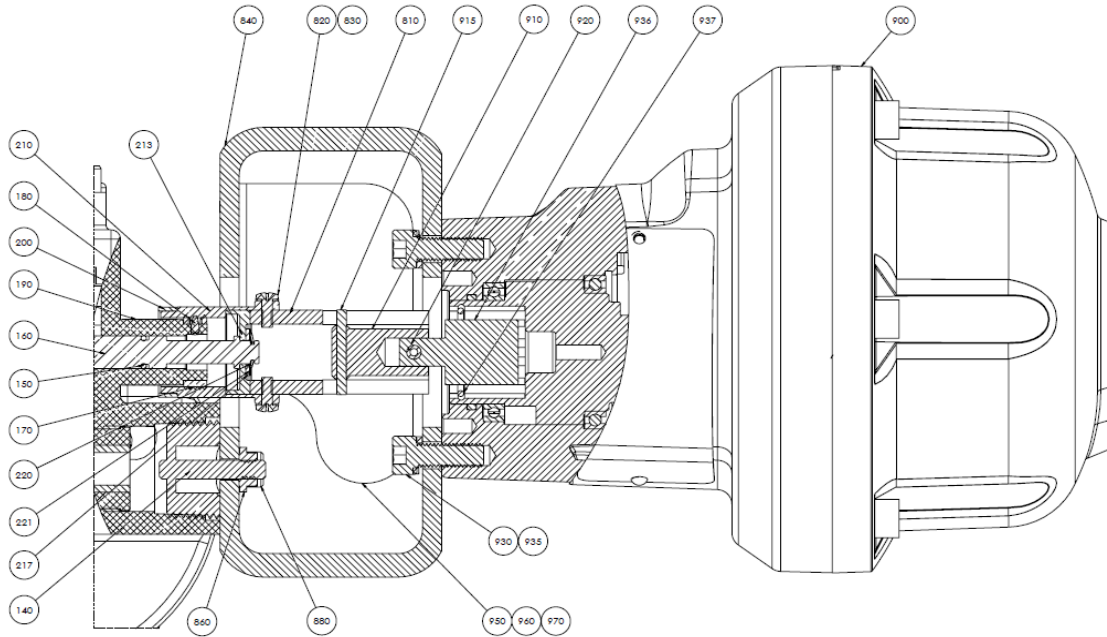
**FIGURE 21. MROY A PLUNGER "H" 316SS LIQUID END
DIRECT ATTACH LEAK DETECTION WITH GAUGE (DWG 9994027392)**

DOUBLE DIAPHRAGM LIQUID END

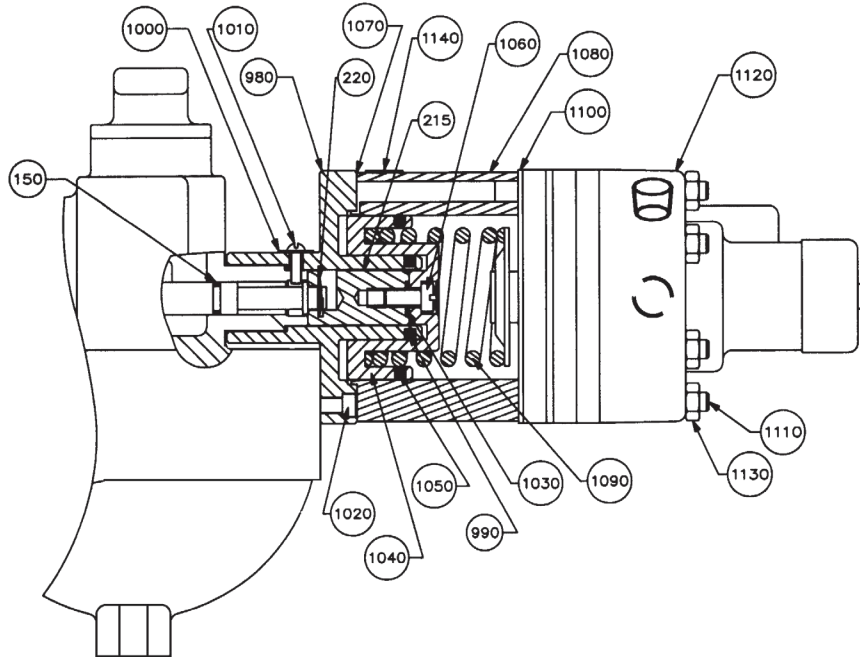
Drawings Applicable to mRoy A - E, F Liquid Ends



**FIGURE 22. MROY A DOUBLE DIAPHRAGM AND LEAK DETECTION
(DWG(S) 99920090005**



ACTUATOR CAPACITY CONTROL



PNEUMATIC CAPACITY CONTROL

**FIGURE 23. MROY A & B ACTUATOR
(DWG(S) 99920090008 & 99920090007)**

6.3 mRoy A BASIC PARTS LIST FOR DRIVE (FIG. 14 &15)

DRAWING LOCATION NUMBER	DESCRIPTION	PART NUMBER	MATERIAL / SPM	QUANTITY
10	HOUSING, MAIN	CONSULT WITH THE AFTERMARKET GROUP FOR REPLACEMENT. PROVIDE SERIAL NUMBER AND MODEL NUMBER OF PUMP.		1
20	CUP, RACE	4090064020	STEEL	1
30	POPPET, RELIEF VALVE	2120056074	NYLON	1
40	SPRING, RELIEF VALVE	2800043041	STEEL	1
50	ADJUSTING SCREW, RELIEF VALVE	4050241014	STEEL	1
60	PLUG - 1/4" NPT, SQ. HEAD	4020009111	STEEL	1
70	GEAR SHAFT BUSHING, (FACTORY INSTALLED, NOT RECOMMENDED FOR FIELD SERVICE, CALL FACTORY)	2370029006	STEEL	1
80	HOUSING SLEEVE 7/16", HIGH VISCOSITY OPTION ONLY	2370073006	STEEL	1
90	PLUNGER, 7/16"	2120055006	STEEL	1
	PLUNGER, 3/8"	2120055106	STEEL	1
	PLUNGER, 5/8"	2120054006	STEEL	1
	PLUNGER, 1-1/16"	2120053006	STEEL	1
100	ROD, CONNECTING	2140025062	ALUMINUM	1
110	PIN, WRIST	2110030006	STEEL	1
125	GEAR SPACER, SIMPLEX	2190071006	STEEL	1
	GEAR SPACER, DUPLEX	2190109006	STEEL	1
130	GEAR SHAFT, SIMPLEX	2680021006	STEEL	1
	GEAR SHAFT, DUPLEX	2680018006	STEEL	1
140	PLUG, 1" NPT SOCKET HEX HEAD	4020095066	18-8SS	1
	PLUG, 1" NPT SOCKET HEX HEAD	4020095067	ECOGUARD COAT. STL	1
	PLUG, 1/2" NPT SOCKET HEX HEAD	4020095046	18-8SS	1
	PLUG, 1/2" NPT SOCKET HEX HEAD	4020095047	ECOGUARD COAT. STL	1
150	O-RING, PARKER 2-011	4080109082	POLYURETHANE	3
160	CONTROL SPOOL	2680037006	STEEL	1
170	SLEEVE, THREADED	2430058016	316SS	1
180	SCREW, SOCKET SET - 6-32NC X 1/4	4050039035		1
190	PLATE, % CAPACITY	2530015062	ALUMINUM	1
200	RING, CALIBRATION	2530024062	ALUMINUM	1
	RING, CALIBRATION	2530024071	PVC	1
210	KNOB, CONTROL	2550019016	316SS	1
	KNOB, CAPACITY ADJUST	2550019071	PVC	1

- Parts Not Illustrated

Parts Continued Next Page

SECTION 6 - PARTS



6.3 mRoy A BASIC PARTS LIST FOR DRIVE (FIG. 14 &15)

DRAWING LOCATION NUMBER	DESCRIPTION	PART NUMBER	MATERIAL / SPM	QUANTITY
	KNOB, CAPACITY ADJUST, (LOCKING MICROMETER)	2550045000		1
220	E-RING - 1/4", CONTROL KNOB	4040124096	STEEL	1
230	PLUNGER, CONTROL	2120036039	STEEL	1
240	ARM, LINKAGE	2140009006	STEEL	1
250	SCREW, LINKAGE - 8-32 X 1/4" SOCKET HEAD	4050245011	STEEL	2
340	O-RING NITRILE	40310	NITRILE	1
345	O-RING URETHANE	4080068032	URETHANE	1
1062	SCREW, SOCKET HEAD - 6-32 X 1, LOCKING MICROMETER KNOB	40201	STEEL	1
1063	NUT, HEX HEAD - 6-32NC (LOCKING MICROMETER)	4050060017	STEEL	1
1330	CAP, RESERVOIR WITH O-RING	43204570060N		1
1340	O-RING, RESERVOIR CAP	4080095071	NBR	1
1350	SCREW PLUG, RELIEF VALVE	4052001011	PLASTIC	1
-	SCREW, MOUNT DATA PLATE	4050280000	STEEL	2
-	PLATE, DATA	2530186000		1
-	DECAL, CAUTION MOTOR	2530021198		1
LUBRICATION				
-	GEAR OIL, ISO 68	4070195010	1 QUART	1
-	GEAR OIL, ISO 220	4070152010	1 QUART	1
-	GEAR OIL, ISO 220	4070152040	1 GALLON	A/R

- Parts Not Illustrated

6.4 mRoy A PARTS COMMON TO METALLIC LIQUID ENDS (FIG. 16 & 17)

DRAWING LOCATION NUMBER	DESCRIPTION	PART NUMBER	MATERIAL / SPM	QUANTITY
280	CONTOUR PLATE-OIL SIDE - 3-1/2"	2980061016	316 SS	1
285	CONTOUR PLATE-PROCESS SIDE, ALSO USED WITH DOUBLE NON-CONTACTING DIAPHRAGMS)	2980061016	316SS	1
		2980061028	ALLOY 20	1
		2980061030	ALLOY C-22	1
360	OPTIONAL BLEEDER SCR DIAPH HEAD	02200210025N	316SS	1
		0220021020N	ALLOY 20	1
		54466	HAST C-22	1
365	O-RING 7.2 X 1.9 FOR OPTIONAL BLEEDER	4380006072N	VITON	1
460	O-RING, DISCHARGE CHECK VALVE CAP	55018	PTFE	1
510	CARTRIDGE, DISCHARGE ASSEMBLY	55022	316SS	1
		55023	ALLOY 20	1
		55024	ALLOY C-22	1
	CARTRIDGE, DISCHARGE ASSEMBLY BSP VERTICAL	54354	316SS	1
		54355	ALLOY 20	1
		54356	ALLOY C-22	1
	CARTRIDGE, DISCHARGE ASSEMBLY BSP HORIZONTAL	54626	316SS	1
		54627	ALLOY 20	1
		54628	ALLOY C-22	1
520	NUT, LOCKING, CHECK VALVE	2090020014	STAINLESS STEEL	1
530	BACK-UP RING, SPIRAL, CHECK VALVE LOCK NUT	4080073141	PTFE	2
540	O-RING, CHECK VALVE LOCK NUT	4080068065	FKM (VITON)	2
600	CARTRIDGE, SUCTION ASSEMBLY (DOUBLE BALL) 1/2" NPT CONNECTION, (EXCEPT MODEL "RP")	2210896216	316SS	1
		2210896228	ALLOY 20	1
		2210896230	ALLOY C-22	1
	CARTRIDGE SUCTION BSP	54304	316 SS	1
		54306	ALLOY 20	1
-	BUSHING, REDUCING - 1/2" X 3/8", USED TO INSTALL NEW SUCTION CHECK VALVE TO	4020001045	316SS	1
		4020001049	ALLOY 20	1

- Parts Not Illustrated

SECTION 6 - PARTS

Diaphragm Head Designs and Diaphragms Are Grouped According to Size and Are Not Interchangeable

6.5 mRoy A DIAPHRAGM HEAD DESIGN- 8 BOLT E & F LIQUID END (FIG. 17)

DRAWING LOCATION NUMBER	DESCRIPTION	PART NUMBER	MATERIAL / SPM	QUANTITY
290	DIAPHRAGM, 8 BOLT E, F LIQUID ENDS	2980005175	PTFE	1
300	RING, INTERMEDIATE, LEAK DETECTION, (CONTACTING DIAPHRAGM)	2190127000	316SS	1
	RING, INTERMEDIATE CHAMBER, DOUBLE	54629	316SS	1
325	CONTOUR PLATE- (PROCESS SIDE) LEAK DETECTION, (CONTACTING DIAPHRAGM)	2980091016	316SS	1
		2980091028	ALLOY 20	1
330	HEAD, DIAPHRAGM - 8 BOLT E & F LIQUID ENDS NO BLEEDER	59881	316 SS	1
		59882	ALLOY 20	1
		54255	HAST C-22	1
330	HEAD, DIAPHRAGM - 8 BOLT E & F LIQUID ENDS WITH BLEEDER	54155	316 SS	1
		54229	ALLOY 20	1
350	SCREW, HEX HEAD - 5/16" X 1-1/4" (HEAD MATERIAL: 1 & 5)	4050017139	STEEL - ULTRA COAT	6
	SCREW, HEX HEAD - 5/16" X 3-1/4" (HEAD MATERIAL CODE 6)	54444	STEEL - ULTRA COAT	8
	SCREW, HEX HEAD - 5/16" X 1-1/2" (HEAD MATERIAL: 1 & 5)	4050017189	STEEL - ULTRA COAT	2

6.6 mRoy A DIAPHRAGM HEAD DESIGN – “H” LIQUID END (FIGURE 18)

DRAWING LOCATION NUMBER	DESCRIPTION	PART NUMBER	MATERIAL / SPM	QUANTITY
281	SPRING PIN 1/16 X 3/8 18-8 S/S	4010001041		2
282	CONTOUR PLATE 3000PSI	59403	316SS	2
289	O-RING 2-041 VITON	4080109385	VITON	1
290	DIAPHRAGM GYLON .040 THK MROY	59852	GYLON	1
304	SPRING PIN 1/16 X 3/8 18-8 S/S	4010001041		3
330	DIAPHRAGM HEAD MROY A NON-LD	59815	316SS	1
350	SCREW 3/8-16X3.25 SHCS ULTRA	54449	STEEL	8
510	DISCH CART 316 2BALL ASSY PTFE	55022	316SS	1
520	LOCK NUT MPIF SS-303-R	2090020014	303 SS	2
530	BACK UP RING, TEFLON, SOLID	40321	PTFE	2
540	O-RING 2-116 VITON	4080068065	FKM (VITON)	2
600	SUCT CARTRIDGE DBL BALL 316/L	2210896216	316 SS	1

6.7 mRoy A “H” (3000 PSI) SPECIFIC PARTS (FIG. 14 & 15)

DRAWING LOCATION NUMBER	DESCRIPTION	PART NUMBER	MATERIAL / SPM	QUANTITY
30	POPPET RELIEF VALVE	59405	BRASS	1
40	SPRING	59478	STEEL	1
90	O-RING, 2-011, 90A DUROMETER	A51004	POLYURETHANE	3
280/285	CONTOUR PLATE 3000PSI	59403	316SS	2
290	DIAPHRAGM GYLON .040 THICK MROY	59852	GYLON	1
330	MRA SMALL HEAD, LEAK DET	59800	316SS	1
330	DIAPHRAGM HEAD MROY A NON-LD	59815	316SS	1
350	SCREW 3/8-16X3.25 SHCS ULTRA	54449	STEEL	8

6.8 mRoy A DIAPHRAGM HEAD DESIGN- 8 BOLT (2-7/8") C & D LIQUID END (FIG. 17)

DRAWING LOCATION NUMBER	DESCRIPTION	PART NUMBER	MATERIAL / SPM	QUANTITY
281	PIN, SPRING - 0.062 X 1/2	4010001061	STEEL	1
282	CONTOUR PLATE-OIL SIDE - 2-1/2" (AFTER 1998)	2980107006	STEEL	1
	CONTOUR PLATE-OIL SIDE - 2-1/2" (BEFORE 1998)	2980007016	316 SS	1
287	CONTOUR PLATE-PROCESS SIDE	2980007016	316SS	1
		2980007028	ALLOY 20	1
289	O-RING - 2-039	21146	VITON	1
290	DIAPHRAGM - 2-7/8" DIAMETER, 8 BOLT DIAPHRAGM DESIGN	2980005275	PTFE	1
330	HEAD, DIAPHRAGM - 2-7/8" DIAMETER, 8 BOLT DIAPHRAGM DESIGN NO BLEEDER	59879	316SS	1
		59880	ALLOY 20	1
		54287	ALLOY C-22	1
	HEAD, DIAPHRAGM - 2-7/8" DIAMETER, 8 BOLT DIAPHRAGM DESIGN WITH BLEEDER	54182	316SS	1
		54282	ALLOY 20	1
350	SCREW, SOCKET HEAD - 5/16-18, 1-1/4" (MATERIAL 1 & 5)	4050017139	STEEL - ULTRA COAT	6
350	SCREW, SOCKET HEAD - 5/16-18 1-1/4" (HEAD MATERIAL: 6)	54444	STEEL - ULTRA COAT	8
355	SCREW, SOCKET HEAD - 5/16-18, 2-1/2"	4050017189	STEEL	2
460	SEAL, DISCHARGE CHECK VALVE CAP	55018	PTFE	1
510	CARTRIDGE ASSEMBLY, DISCHARGE (DOUBLE BALL)	55022	316SS	1
		55023	ALLOY 20	1
		55024	HAST C-22	1
	CARTRIDGE ASSEMBLY DISCHARGE (DOUBLE BALL) BSP VERTICAL	54354	316SS	1
		54355	ALLOY 20	1
		54356	HAST C-22	1
	CARTRIDGE ASSEMBLY DISCHARGE (DOUBLE BALL) BSP VERTICAL	54626	316 SS	1
		54627	ALLOY 20	1
		54628	HAST C-22	1
520	NUT, LOCKING, CHECK VALVE	2090020014	STAINLESS STEEL	1
530	RING, SPIRAL BACK-UP, CHECK VALVE	4080073141	PTFE	2
540	O-RING, CHECK VALVE LOCK NUT	4080068065	FKM (VITON)	2
600	CARTRIDGE ASSEMBLY, SUCTION (DOUBLE BALL) 1/2" NPT CONNECTION	2210896216	316SS	1
		2210896228	ALLOY 20	1
		2210896230	HAST C-22	1
	CARTRIDGE ASSEMBLY, SUCTION BSP	54304	316 SS	1
		54306	ALLOY 20	1
	54308	HAST C-22	1	

- Parts Not Illustrated

SECTION 6 - PARTS

6.9 mRoy A HIGH VISCOSITY "V" OPTION (FIG. 16)

DRAWING LOCATION NUMBER	DESCRIPTION	PART NUMBER	MATERIAL / SPM	QUANTITY
330	HEAD	59881	316 SS	1
		59882	ALLOY 20	1
		54255	HAST C-22	1
330	HEAD	54155	316 SS	1
		54229	ALLOY 20	1
		54255	HAST C-22	1
570	BALL CHECK, SUCTION - 5/8"	4070014172	316 SS	1
		4070014173	ALLOY 20	1
		4070014076	ALLOY C	1
		2210864016	316 SS	1
600	VALVE BODY, SUCTION	2210864028	ALLOY -20	1
		2210864030	ALLOY C-22	1

6.10 mRoy A: E & F PLASTIC LIQUID END PARTS (FIG. 16)

DRAWING LOCATION NUMBER	DESCRIPTION	PART NUMBER	MATERIAL / SPM	QUANTITY
280	CONTOUR PLATE	2980061016	316 SS	1
289	O-RING - 2-044	4080109415	VITON	1
		54459	TEFLEX	1
		54460	EPDM	1
290	DIAPHRAGM 3.98 VIRGIN TEFLON	2980005175	PTFE	1
330	HEAD	54092	PVC	1
340	PLATE, BACK-UP	54321	304 SS	1
350	SCREW, HEX HEAD - 5/16-18 X 2	4050017163	18-8 SS	8
360	FASTPRIME VALVE	48848	PVC	1
435	SEAL- HEAD TO CHECK VALVE (PVC & PVDF CHECKS)	4080143075	PTFE	2
500	NUT, COUPLING - TUBING CONNECTION ONLY	4070350079		2
490	CHECK VALVE ASSEMBLY, SUCTION -TUBE END	20287	PVC	1
PARTS INCLUDED	O-RING - 3/8 X 3/32	2250032675	PTFE	2
	BALL STOP	20289	PVC	2
	SEAT	20290	PVC	2
	BALL, 3/8 AD995	4070015111	CERAMIC	2
	BODY, CARTRIDGE	20288	PVC	1
490	SUCTION ASSEMBLY, NPT	20299	PVC	1
	SUCTION ASSEMBLY, BSP	54379	PVC	1
PARTS INCLUDED	O-RING - 3/8 X 3/32	2250032675	PTFE	2
	BALL STOP	20289	PVC	2
	SEAT	20290	PVC	2
	BALL, 3/8 AD995	4070015111	CERAMIC	2
	BODY, CARTRIDGE	20291	PVC	1
495	DISCHARGE ASSEMBLY-TUBE END	20292	PVC	1

- Parts Not Illustrated

Parts Continued Next Page

6.10 mRoy A: E & F PLASTIC LIQUID END PARTS (FIG. 16)

PARTS INCLUDED	O-RING - 3/8 X 3/32	2250032675	PTFE	2
	BALL STOP	20289	PVC	2
	SEAT	20290	PVC	2
	BALL, 3/8 AD995	4070015111	CERAMIC	2
	BODY, CARTRIDGE	20288	PVC	1
495	DISCHARGE ASSEMBLY, NPT	20302	PVC	1
	DISCHARGE ASSEMBLY, BSP	54364	PVC	1
PARTS INCLUDED	O-RING - 3/8 X 3/32	2250032675	PTFE	2
	BALL STOP	20289	PVC	2
	SEAT	20290	PVC	2
	BALL, 3/8 AD995	4070015111	CERAMIC	2
	BODY, CARTRIDGE	20291	PVC	1

6.10 mRoy A: C & D PLASTIC LIQUID END PARTS (FIG. 16)

DRAWING LOCATION NUMBER	DESCRIPTION	PART NUMBER	MATERIAL / SPM	QUANTITY
90	SEAL- HEAD TO CHECK VALVE (PVC & PVDF CHECKS)	39413	PTFE	1
280	CONTOUR PLATE	2980007016	316 SS	1
281	SPRING PIN	4010001041		1
289	O-RING - 2-039	21146	VITON	1
		54458	TEFLEX	1
		52663	EPDM	1
290	DIAPHRAGM	2980005275	PTFE	1
330	HEAD	53961	PVC	1
340	PLATE, BACK-UP	54320	304 SS	1
350	SCREW, HEX HEAD - 5/16-18 X 2-1/4	54441	18-8 SS	8
360	FASTPRIME VALVE	48848	PVC	1
470	CHECK VALVE ASSEMBLY, SUCTION NPT	49163	PVC	1
	CHECK VALVE ASSEMBLY, SUCTION BSP	54383	PVC	1
480	CHECK VALVE ASSEMBLY DISCHARGE NPT	49243	PVC	1
	CHECK VALVE ASSEMBLY, DISCHARGE BSP	54375	PVC	1

- Parts Not Illustrated

SECTION 6 - PARTS

6.11 mRoy A MOTOR MOUNT PARTS (FIG.14 & 15)

Close Coupled Flange Mount NEMA 56C (CC with S5 or 5X)

(NEMA 56C) Worm and Shaft Assembly includes Worm Shaft (640), Worm (650), Pin (660), Cone Bearing (670) and Spring (740).

DRAWING LOCATION NUMBER	DESCRIPTION	PART NUMBER		MATERIAL / SPM	QUANTITY
650	WORM, WORM GEAR AND SHAFT ASSEMBLY	54679	77:1	23 SPM @1725 RPM	1
		54680	48:1	37 SPM @1725 RPM	1
		54681	24:1	73 SPM @1725 RPM	1
		54682		117 SPM @1725 RPM	1
		54683	9.5:1	185 SPM @1725 RPM	1
670	BEARING, TAPERED ROLLE	4090066010			1
680		4099994000			1
710	PLATE MOTOR, MOUNT	2720130062		ALUMINUM	1
720	GASKET, MOTOR	23057		STEEL	4
730	3/8-16 X 5/8 SCREW SOCKET HD	4050029086		RUBBER	2
740	SPRING, COMPRESSION	4030166011		STEEL	1
770	SCREW 1/4-20 X 1 SOCKET HD	4050027111		STEEL	2

6.11 mRoy A MOTOR MOUNT PARTS (FIG. 14 & 15)

Close Coupled Flange IEC Frame 71, B5 (CC with S7 or 7X)

(IEC Frame 71, B5) Worm and Shaft Assembly includes Worm Shaft (640), Worm (650), Pin (660), Cone Bearing (670) and Spring (740).

DRAWING LOCATION NUMBER	DESCRIPTION	PART NUMBER		MATERIAL / SPM	QUANTITY
650	WORM AND WORM GEAR AND SHAFT ASSEMBLY	54674	77:1	23 SPM @1725 RPM	1
		54675	48:1	37 SPM @1725 RPM	1
		54676	24:1	73 SPM @1725 RPM	1
		54677	15:1	117 SPM @1725 RPM	1
		54678	9.5:1	185 SPM @1725 RPM	1
670	BEARING, TAPERED ROLLER	4090066010			1
680		4099994000			1
710	PLATE IEC MOTOR MOUNT	2720130062		ALUMINUM	1
720	GASKET, MOTOR	23057		RUBBER	1
-	GASKET, IEC71 MOTOR	2250121099		RUBBER	1
730	SHCS 8MM X 1.25 X 30	4052007074		STEEL	4
740	SPRING	60059		STEEL	1
770	SCREW 1/4-20 X 1 SOCKET HD	4050027111		STEEL	2

- Parts Not Illustrated

Parts Continued Next Page

6.11 mRoy A MOTOR MOUNT PARTS (FIG. 14 & 15)

Parts Common to all API Motor Mounts (A)

(NEMA 56C) Stub Shaft Assembly includes Worm Shaft (640), Worm (650), Pin (660), Cone Bearing (670), & Ball bearing (680).

<i>FR (NEMA 56C) STUB SHAFT ASSEMBLY INCLUDES WORM SHAFT (640), WORM (650), PIN (660), CONE BEARING (670), & BALL BEARING (680).</i>					
640	SHAFT, WORM	2520048006		STEEL	1
650	WORM, GEAR, & SHAFT ASSEMBLY	54684	77:1	23 SPM @1725 RPM	1
		54685	48:1	37 SPM @1725 RPM	1
		54686	24:1	73 SPM @1725 RPM	1
		54687	15:1	117 SPM @1725 RPM	1
		54688	9.5:1	185 SPM @1725 RPM	
670	BEARING, CONE	4090064010			
680	BEARING, BALL	4090094020			

API Flange Mount NEMA 56C (FR)

DRAWING LOCATION NUMBER	DESCRIPTION	PART NUMBER	MATERIAL / SPM	QUANTITY
75	PLUG, EXPANSION - 9/32	40059	STEEL	2
690	WASHER, FLAT	2190030006	STEEL	1
700	SPRING, FINGER - 0.563	4030121006	STEEL	1
710	ADAPTER, MOTOR	2720090001	CAST IRON	1
770	SCREW, SOCKET HEAD - 8-32NC X 3/4	4050132031	STEEL	4
780	COUPLING - 1/2 X 5/8 KEY	4100127040		1
790	SCREW, HEX HEAD - 3/8-16 X 1 GR5	4050018119	STEEL	4
800	PLUG, SQ. HEAD PIPE - 1/2" NPT	4020009137	STEEL	1

Parts Continued Next Page

SECTION 6 - PARTS

6.11 mRoy A MOTOR MOUNT PARTS (FIGURES 14 & 15)

API Flange Mount NEMA 143/145TC (F4)

DRAWING LOCATION NUMBER	DESCRIPTION	PART NUMBER	MATERIAL / SPM	QUANTITY
75	PLUG, EXPANSION - 9/32	40059	STEEL	2
690	WASHER, FLAT	2190030006		1
700	SPRING, FINGER - 0.563	4030121006		1
710	ADAPTER, NEMA 56C - 143/145 TC	2720090001		1
770	SCREW, SOCKET HEAD - 8-32NC X 3/4	4050132031	STEEL	4
780	COUPLING - 5/8 X 7/8 3/16 KEY	4100064120		1
790	SCREW, HEX HEAD - 3/8-16 X 1 GR5	4050018119		4

API Flange Mount NEMA IEC Frame 71, B5 (FS)

DRAWING LOCATION NUMBER	DESCRIPTION	PART NUMBER	MATERIAL / SPM	QUANTITY
75	PLUG, EXPANSION - 9/32	40059	STEEL	2
690	WASHER, FLAT	2190030006		1
700	SPRING, FINGER - 0.563	4030121006		1
710	ADAPTER, MOTOR, MROY A API IEC	2720146001		1
770	SCREW, SOCKET HEAD - 8-32NC X 1/4	4050132031	STEEL	4
780	COUPLING - 1/2 X 14MM (LOVEJOY L095)	40202		1
-	NUT, HEX - 5/16-18NC	4050065013		
790	SCREW, HEX HEAD - 3/8-16 X 1 GR5	4050018119	STEEL	4
-	LOCK-WASHER, SPRING - 5/16	4040040028		
800	PLUG, SQ. HEAD PIPE - 1/2" NPT	4020009137	STEEL	1

API Flange Mount IEC 80 B5 (MD)

DRAWING LOCATION NUMBER	DESCRIPTION	PART NUMBER	MATERIAL / SPM	QUANTITY
75	PLUG, EXPANSION - 9/32	40059	STEEL	2
690	WASHER, FLAT	2190030006		1
700	SPRING, FINGER - 0.563	4030121006		1
710	ADAPTER, MOTOR - IEC 80 B5	2720090001		1
-	PLATE, MOTOR ADAPTER	60199		1
770	SCREW, SOCKET HEAD - 8-32NC X 3/4	4050132031	STEEL	4
780	COUPLING - 5/8 X 19MM (LOVEJOY L-100)	40244		1
790	SCREW, HEX HEAD - M10 X 25MM	4350001732	STEEL	4
800	PLUG, SQ. HEAD PIPE - 1/2" NPT	4020009137	STEEL	1

- Parts Not Illustrated

Parts Continued Next Page

6.12 mRoy A ACTUATED CAPACITY CONTROL MOUNTING (FIGURE 22)

Complete Kits: 30268 7/16", 3/8" & 5/8" plungers & 335-1401-040 for 1-1/16" plunger. Parts included are below:

DRAWING LOCATION NUMBER	DESCRIPTION	PART NUMBER	MATERIAL / SPM	QUANTITY
140	PLUG, ADAPTER - RA & RP PUMPS (1" NPT)	2430045020	STEEL	1
	PLUG, ADAPTER - RT, RH, & RJ PUMPS (1/2" NPT)	2430045000	STEEL	1
150	O-RING, PARKER - 2-011	4080109082	POLYURETHANE	3
160	CONTROL SPOOL	2680037006	STEEL	1
170	SLEEVE, THREADED	2430058016	316SS	1
180	SCREW, SOCKET SET - 6-32NC X 1/4	4050039035		1
190	PLATE, % CAPACITY	2530015062	ALUMINUM	1
200	RING, CALIBRATION	2530024062	ALUMINUM	1
210	KNOB, CAPACITY ADJUST	2550035077	ACETAL	1
213	BEARING, CONTROL SPOOL ECC	2370076052		1
217	WASHER, THRUST - 5/16	4040147031	STEEL	1
220	E-RING (1/4" FOR CONTROL KNOB)	4040124096	STEEL	1
810	COUPLING, DRIVE ECC	2520138077		1
820	LOCK-WASHER- #6	4040104071	STEEL, ZINC PLATED	2
830	SCREW, PAN HEAD - 6-32NC X 3/8	4050178033	18.8SS	2
840	BRACKET, MOUNTING, MROY A ECC	2040149006		1
860	NUT, SERRATED FLANGE - 1/4-20NC	4050323036	STEEL, ZINC PLATED	1
880	SCREW, SOCKET HEAD - 5/16-18 X 5/8	4050157024	STEEL / NYLON	1
900	ACTUATOR (MROY)	PER SPEC		1
910	SHAFT, DRIVE ECC ASSEMBLY: INCLUDES ITEMS: 915 & 920.	2680055000		1
915	PIN, DOWEL - 1/8" ASSEMBLE W/268- 0052- 077	4010021133		1
920	PIN, SPRING - 0. 187DIA.X 5/8	4010005032	STEEL	1
930	LOCK-WASHER, SPRING - 3/8"	4040041022	18.8SS	4
935	SCREW, HEX HEAD - 3/8-16 X 3/4	4050018096	STEEL, ZINC PLATED	4
950	GUARD, LEFT SIDE ECC	2490110006	STEEL	1
960	GUARD, RIGHT SIDE ECC	2490109006	STEEL	1
970	SCREW, BUTTON HEAD - 10-32 X 5/16	4050282087	18.8SS	4
1440	MROY ECC INSTRUCTION MANUAL	3390083000		1

- Parts Not Illustrated

SECTION 6 - PARTS

6.13 PNEUMATIC CAPACITY CONTROL (3-15 PSI DIRECT, FIGURE 23)

DRAWING LOCATION NUMBER	DESCRIPTION	PART NUMBER	MATERIAL / SPM	QUANTITY
140	ADAPTER PLUG 1/2 NPT	2430045000	316SS	1
150	O-RING 2-011 70 DURO URETHANE	4080109082	URETHANE	3
160	CONTROL SPOOL 304SS	2680037006	304SS	1
170	THREADED SLEEVE 316SS	2430058016	316SS	1
180	SOC SET SCR CPT 6-32NCX1/4	4050039035	18-8SS	1
190	CAP PLATE ALUM - DEAD SOFT	2530015062	ALUMINUM	1
200	CALIBRATION RING ALUMINUM RA	2530024062	ALUMINUM	1
210	CAPACITY ADJUST KNOB DELRIN	2550035077	DELRIN	1
213	CONTROL SPOOL BEARING ECC RA	2370076052	BRONZE	1
217	THRUST WASHER 5/16 STEEL	4040147031	STEEL	1
220	CLIP 1/4 E-RING EXTERNAL	4040124096	STEEL	1
221	SHIM FASTENAL NUMBER 7041808	55916	STEEL	1
810	ECC DRIVE COUPLING RA	2520138077	DELRIN	1
820	INT TOOTH LOCK WASHER #6 Z PL	4040104071	STEEL	2
830	PAN HD SCR #6-32NCX3/8 18.8SS	4050178033	18-8SS	2
840	MROY A BRACKET ECC BERNARD	56863	STEEL	1
860	SERR FLANGE NUT 1/4-20NC Z PLT	4050323036	STEEL	1
880	SOC HD SCR 5/16-18X5/8 STL NYL	4050157024	STEEL	1
900	ACTUATOR ACC 10T EX-PROOF LT°	0280087010N		1
910	DRIVE SHAFT, MROY A ECC	2680052077	DELRIN	1
915	DOWEL PIN 1/8 X 1-1/8 STL	4010021133	STEEL	1
920	SPRING PIN 3/16 X 5/8 420SS	4010005032	420SS	1
930	LOCK WASHER, M8,316SS	52957	316SS	4
935	ECOGUARD SHCS M8X20 CLASS 12.9	57109	STEEL	4
936	ECC BERNARD SPLINE SHAFT	56864	304SS	1
937	SHAFT RETAINER RING D28	4340065001N	STEEL	1
950	LEFT SIDE ECC GUARD RA	2490110006	STEEL	1
960	RIGHT SIDE ECC GUARD RA	2490109006	STEEL	1
970	BTN HD SC SCR #10-32X5/16 18-8	4050282087	18-8SS	4

6.14 mRoy A SIMPLEX LEAK DETECTION PARTS, FIGURE 22 (DOUBLE QUANTITIES FOR DUPLEX PUMPS) (THIS PARTS LIST IS APPLICABLE ONLY TO mRoy E, F PUMPS, ALSO "V" CHECK VALVE OPTION).

DRAWING LOCATION NUMBER	DESCRIPTION	PART NUMBER	MATERIAL / SPM	QUANTITY
290	DIAPHRAGM E & F PLUNGERS	2980005175	PTFE	2
300	RING ASSEMBLY, INTERMEDIATE E & F	2190127000	316 SS	1
320	CONTOUR PLATE, PROCESS SIDE	2980091016	316 SS	1
325	CONTOUR PLATE, OIL SIDE	2980091016	316 SS	1
350	SCREW, HEX HEAD - 5/16-18 X 1-1/2 GR5,	4050017149	STEEL	6
355	SCREW, HEX HEAD - 5/16-18 X 2-3/4 GR5	4050017199	STEEL	2
360	BASE, SIMPLEX MROY A	2010441006	STEEL	1
	BASE, DUPLEX MROY A	2010434006	STEEL	1
370	SCREW, HEX HEAD - 5/16-18 X 1-1/4 GR5	4050017139	STEEL	3

Parts Continued Next Page

SECTION 6 - PARTS

6.14 mRoy A SIMPLEX LEAK DETECTION PARTS, FIGURE 22 (DOUBLE QUANTITIES FOR DUPLEX PUMPS)

380	BRACKET	2040199006	STEEL	1
390	LOCK-WASHER, SPRING - 5/16	4040040028	ZINC PLATED	3
400	NUT, HEX - 5/16-18NC	4050065013	18-8 SS	3
1150	CHECK VALVE - 1/8TUBE, 1/3 PSI	40065	316 SS	1
1160	GAGE, PRESS - 0-400PSI, DUAL FLANGE MOUNT	40066		1
	GAGE, PRESS - 1000PSI, DUAL FLANGE MOUNT	40176		1
1170	ADAPTER, RED - 1/4F X 1/8M, NPT	40067	316 SS	1
1180	TEE, BRANCH - 1/8NPTF X 1/8 TUBE	40060	316 SS	1
1190	TEE, - 1/8NPT FEMALE	40062	316 SS	1
1191	TEE, - 1/8NPT FEMALE	40062	316 SS	1
1200	TUBE CONN.- 1/8 TUBE X 1/8 NPT	40061	316 SS	1
1201	TUBE CONN.- 1/8 TUBE X 1/8 NPT	40061	316 SS	2
1210	VALVE, BLEED WITH TUBING CONNECTION	59891	316 SS	1
1220	SCREW, PAN HEAD - 4-40 X 1/2	4050263050	ZINC PLATED	3
1230	LOCK-WASHER, SPRING #4	4040095023	18-8 SS	3
1240	NUT, HEX - 4-40NC	4050182012	18.8 SS	3
1250	SWITCH, PRESSURE, NEMA 4 - 5-30 PSI	4060388001		1
1250	SWITCH, PRESSURE, NEMA 7 - 5-30 PSI	4060389001		1
1260	NIPPLE, RED HEX - 1/2X1/8, NPT	40064	316 SS	1
1270	SCREW, HEX HEAD - 1/4-20X3/4	4050016095	18-8 SS	2
1280	LOCK-WASHER, SPRING - 1/4	4040039022	18.8 SS	2
1290	NUT, HEX - 1/4-20NC	4050064012	18.8 SS	2
1300	TUBING, PUMP TO GAUGE (FORMED)	2490137116		1
	TUBE - 1/8 OD X 0.035 WALL	4020502993	316 SS	12 IN.
1320	TUBING, GAUGE TO SWITCH NEMA 4	2490136016		1
	TUBING, GAUGE TO SWITCH NEMA 7	2490138016		1
	TUBING, - 1/8 OD X 0.035 WALL	4020502993	316 SS	20 IN.
-	LEAK DETECTOR INSTRUCTION MANUAL	3390036000		1
-	MINERAL OIL (AVAILABLE AT DRUG STORES)			

- Parts Not Illustrated

SECTION 6 - PARTS



6.14 mRoy A SIMPLEX LEAK DETECTION PARTS, FIGURE 20 (DOUBLE QUANTITIES FOR DUPLEX PUMPS) (THIS PARTS LIST IS APPLICABLE ONLY TO mRoy C, D, PUMPS, ALSO "V" CHECK VALVE OPTION)

DRAWING LOCATION NUMBER	DESCRIPTION	PART NUMBER	MATERIAL / SPM	QUANTITY
289	O-RING 2-041 VITON	4080109385	VITON	1
290	DIAPHRAGM XT- GYLON .030 THK	40741	GYLON	2
300	INTERMEDIATE RING -A- XT11	21029	316 SS	2
301	INTERMEDIATE RING-B- XT11	21031	316 SS	2
304	SPRING PIN 1/16 X 3/8 18-8 S/S	4010001041		3
320	CONTOUR 316SS	22134	316 SS	1
350	HEX HD SCREW 3/8-16 X 3-1/4 GR8	54461	STEEL	8
360	BASE, SIMPLEX MROY A	2010441006		1
	BASE, DUPLEX MROY A	2010434006		1
370	HEX HD SCR 5/16-18X1-1/4 GR8	4050017139	STEEL	2
380	BRACKET	2040199006	316 SS	1
390	SPRING LOCK WASHER 5/16 Z PL	4040040028	SS	2
400	5/16-18 HEX NUT SS	C00065	SS	2
1148	TUBE CONN 1/8 TUBEX 1/8NPT 316	40061	316SS	1
1148	TUBE CONN 1/8 TUBEX 1/8NPT 316	40061	316SS	1
1150	CHECK VALVE 1/8TUBE 1/3PSI 316	40065	316SS	1
1160	PRESS GAGE 0-5000 PSI DUAL FLG	40405		1
1170	RED ADAPTER 1/4F X1/8M NPT 316	40067	316SS	1
1191	TEE 1/8NPT FEMALE 316SS	40062	316SS	1
1210	BLEED VALVE 1/8 NPT 316SS	59891	316SS	1
1220	PAN HD SCR #4-40X1/2 ZNCR	4050263050		3
1230	SPRING LOCK WASHER #4 18-8SS	4040095023	18-8 SS	3
1240	4-40 NUT SS	C00051	SS	3
1270	HEX HD SCREW 1/4-20X3/4 18-8SS	4050016095	SS	2
1280	WASHER, 1/4" SPLIT LOCK, 18-8	L12216	18-8SS	2

SECTION 6 - PARTS

6.15 mRoy A & B DIRECT ATTACH LEAK DETECTION PARTS, FIGURE 21. THIS PARTS LIST IS APPLICABLE ONLY TO mRoy C, D, H PUMPS, LEAK DETECTION OPTION "2"

DRAWING LOCATION NUMBER	DESCRIPTION	PART NUMBER	MATERIAL / SPM	QUANTITY
801	LEAK DETECTION ADAPTER	59801	316SS	1
802	POPPET - LEAK DET ADAPTER	59802	PEEK	1
803	1/8NPT CONNECTOR FEMALE	59803	316SS	1
804	SPRING PIN 3/16"DIA X 5/8"L	59804	18-8SS	1
805	SPRING .75"L X .18OD X .132"ID	59805	STEEL	1
806	HEX HEAD PLUG 1/8NPT MALE	59806	316SS	1
807	O-RING -010 70DURO	59807	BUNA-N	1
808	1/8NPT BARBHOSE FITTING 1/8"ID	59808	316SS	1
809	3000PSI 2.5" 1/4NPT MALE GAUGE	59809	316SS	1
810	HEX NUT 3/8"-24, 5/8"W, 7/32"H	59810	316SS	1
811	BLEEDER SCR DIAPH HEAD 316S	02200210025N	316SS	1
812	O-RING 7.2 X 1.9	4380006072N	VITON	1

6.16 mRoy A DOUBLE DIAPHRAGM PARTS E & F PLUNGERS (FIGURE 22)

DRAWING LOCATION NUMBER	DESCRIPTION	PART NUMBER	MATERIAL / SPM	QUANTITY
285	CONTOUR PLATE, PROCESS SIDE, ALSO USED WITH DOUBLE NON-CONTACTING DIAPHRAGMS)	2980091016	316SS	1
		2980091028	ALLOY 20	1
		2980091030	ALLOY C-22	1
290	DIAPHRAGM (4", 8 BOLT DESIGN), MODEL "RJ"	2980005175	PTFE	2
300	RING ASSEMBLY, INTERMEDIATE	54817		1
-	PROBE, ALARM CONDUCTIVITY	3010307000		1
310	PLUG, - 1/8" THRD. SQ HEAD PIPE	4020011013		1
350	SCREW, HEX HEAD - 5/16-18 X 3	4020017233	STEEL	6
-	OIL, VEGETABLE	40104		0.013 GAL

SECTION 6 - PARTS

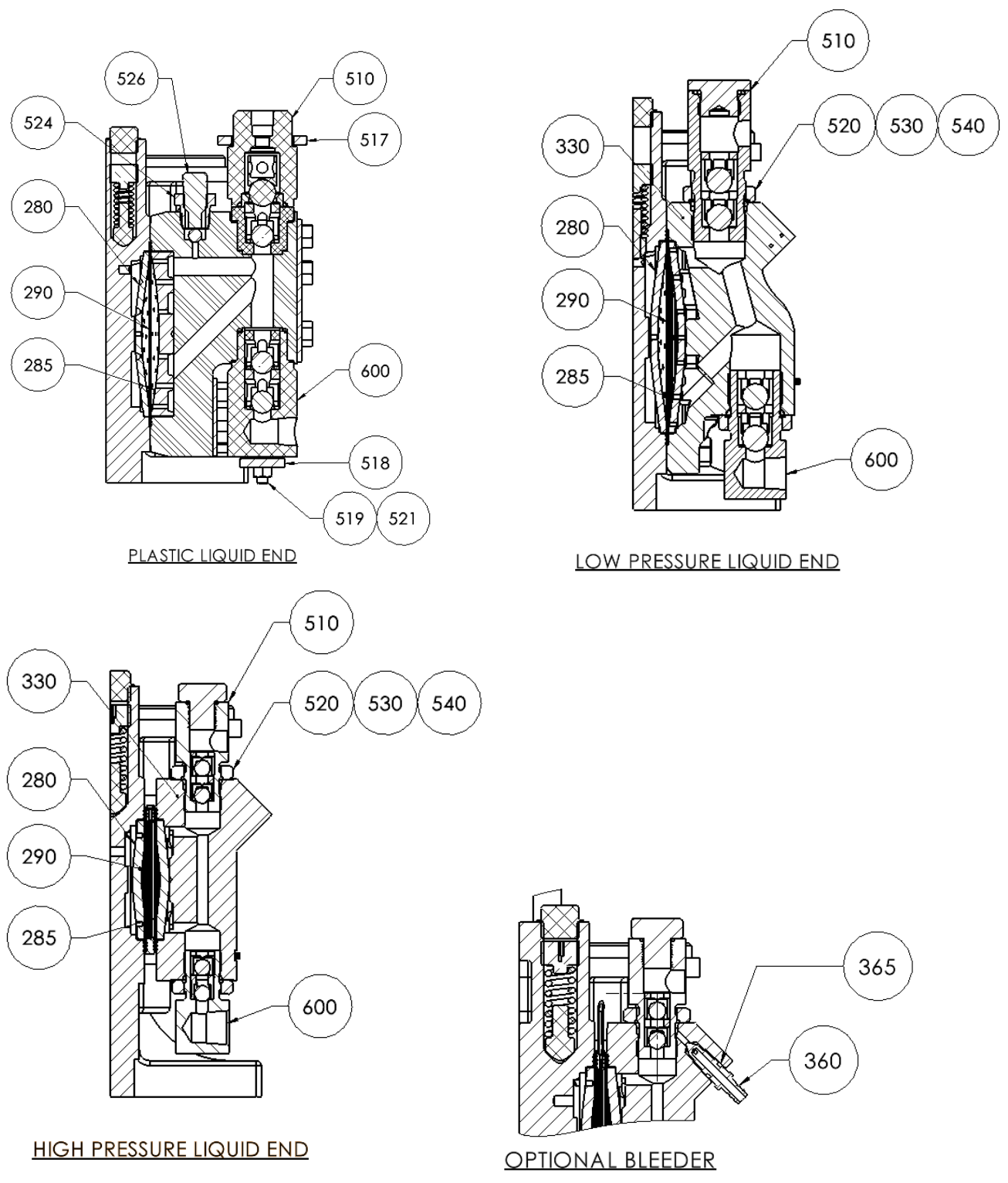


FIGURE 24. MROY B Metallic and Plastic Liquid End (DWG 99920100012)

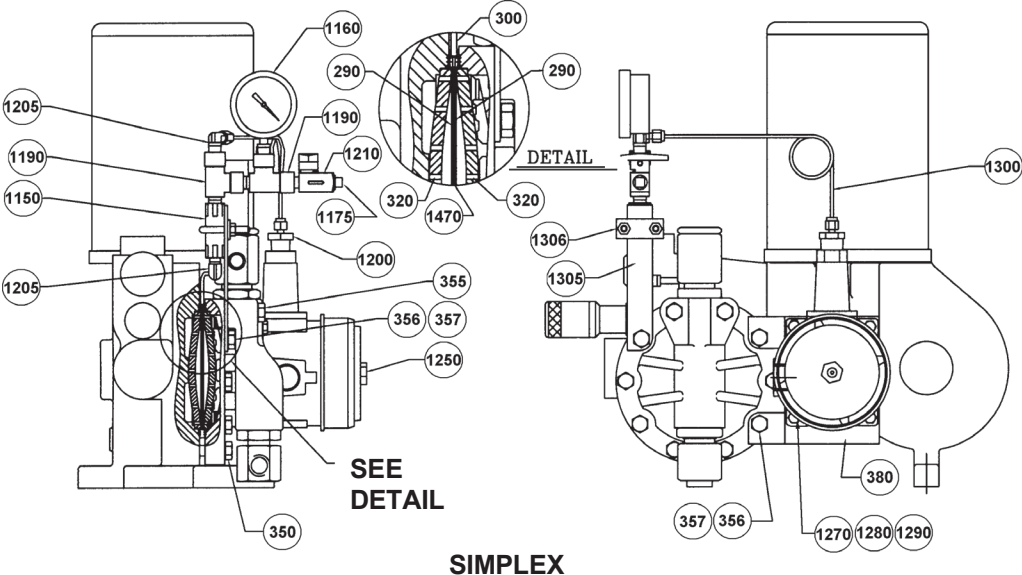


FIGURE 25. MROY B LEAK DETECTION WITH SWITCH AND GAUGE (DWG 99920100005)

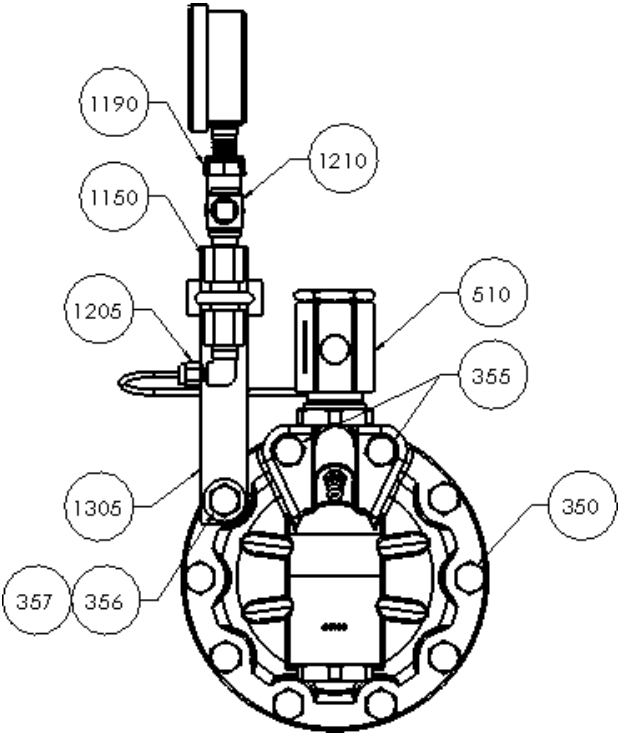


FIGURE 26. MROY B GAUGE ONLY (99920100005)

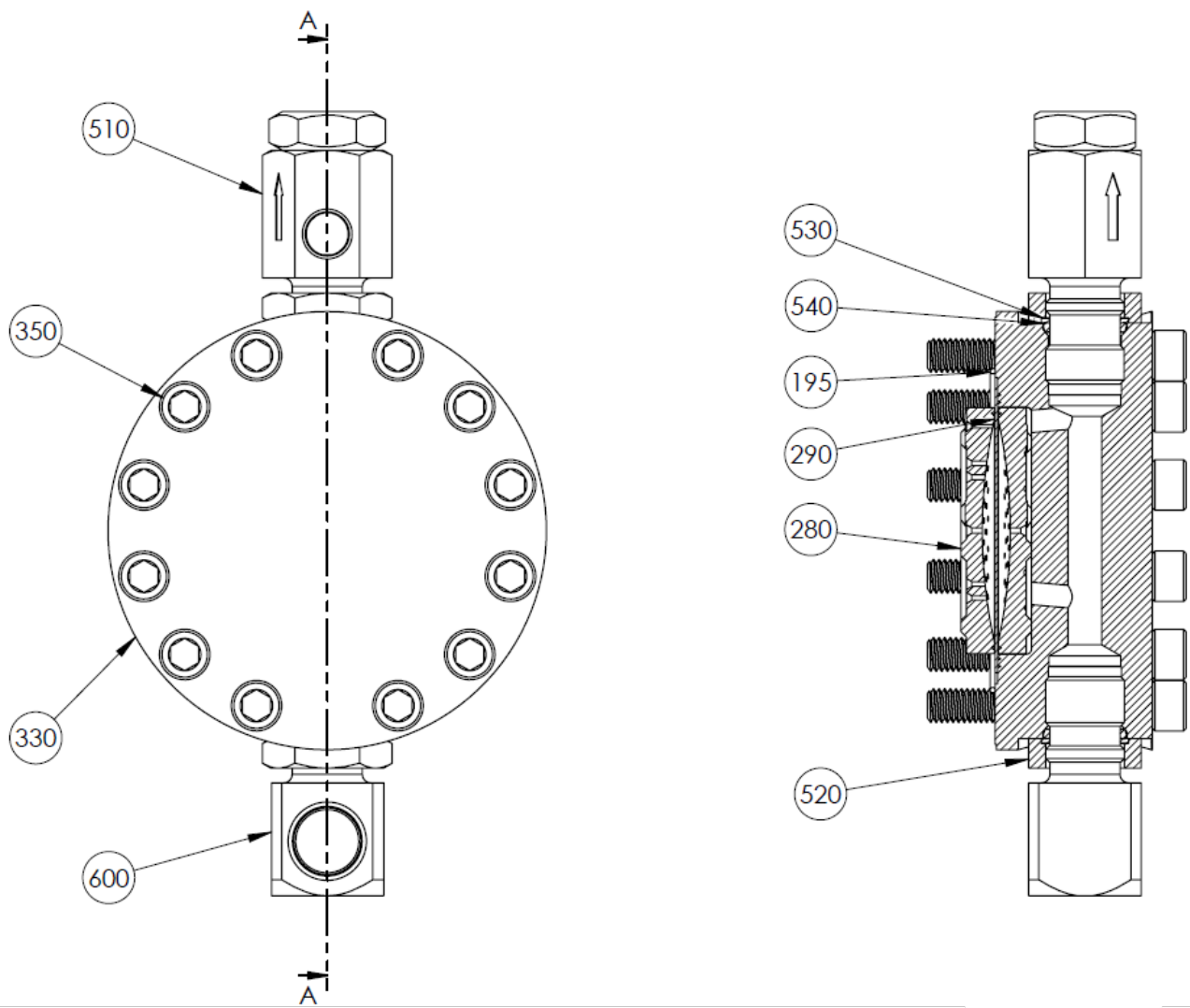


FIGURE 27. MROY B PLUNGER "H" 316SS LIQUID END
(DWG 9994027404)

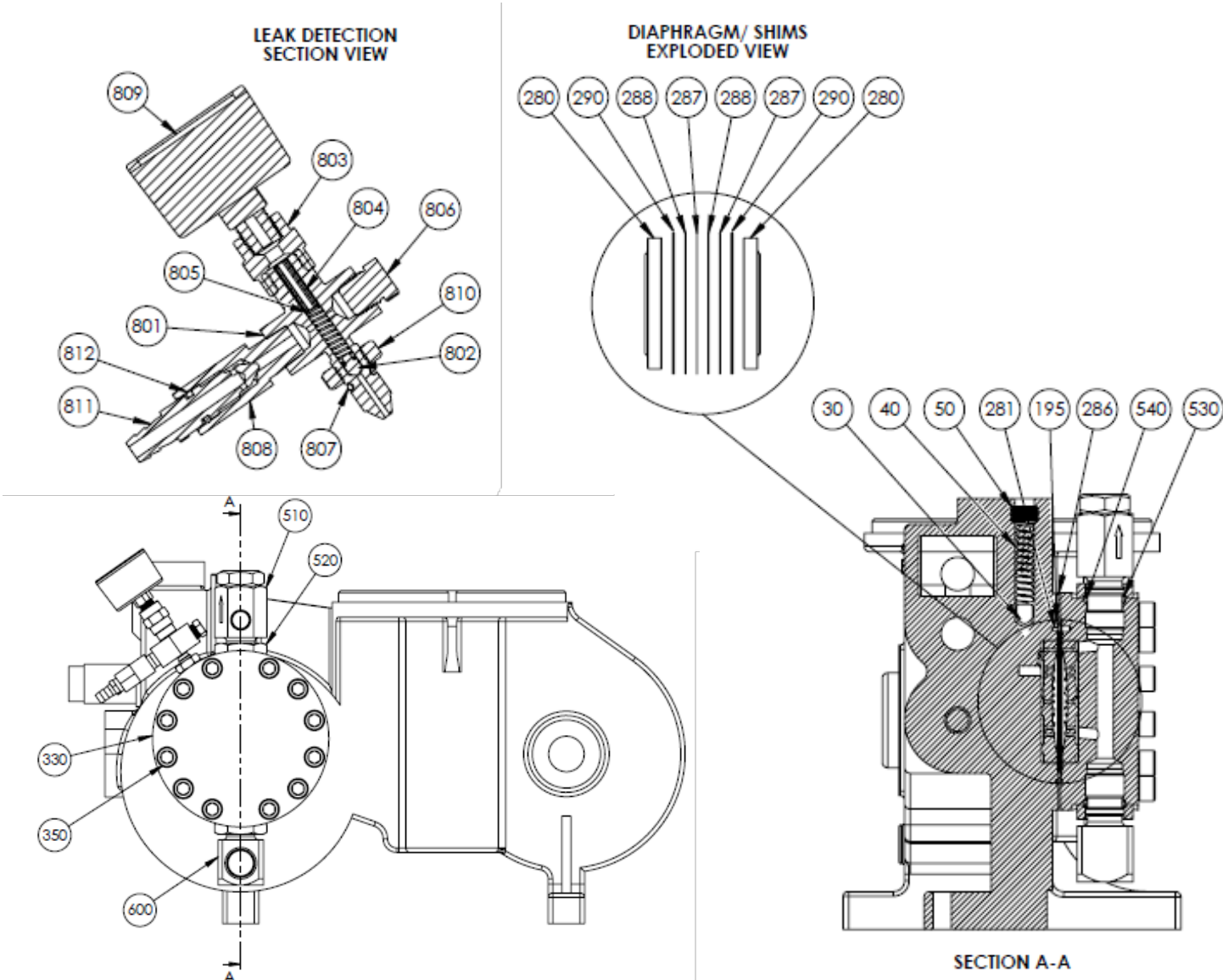


FIGURE 28. MROY B PLUNGER "H" 316SS LIQUID END DIRECT ATTACH LEAK DETECTION WITH GAUGE (DWG 9994027403)

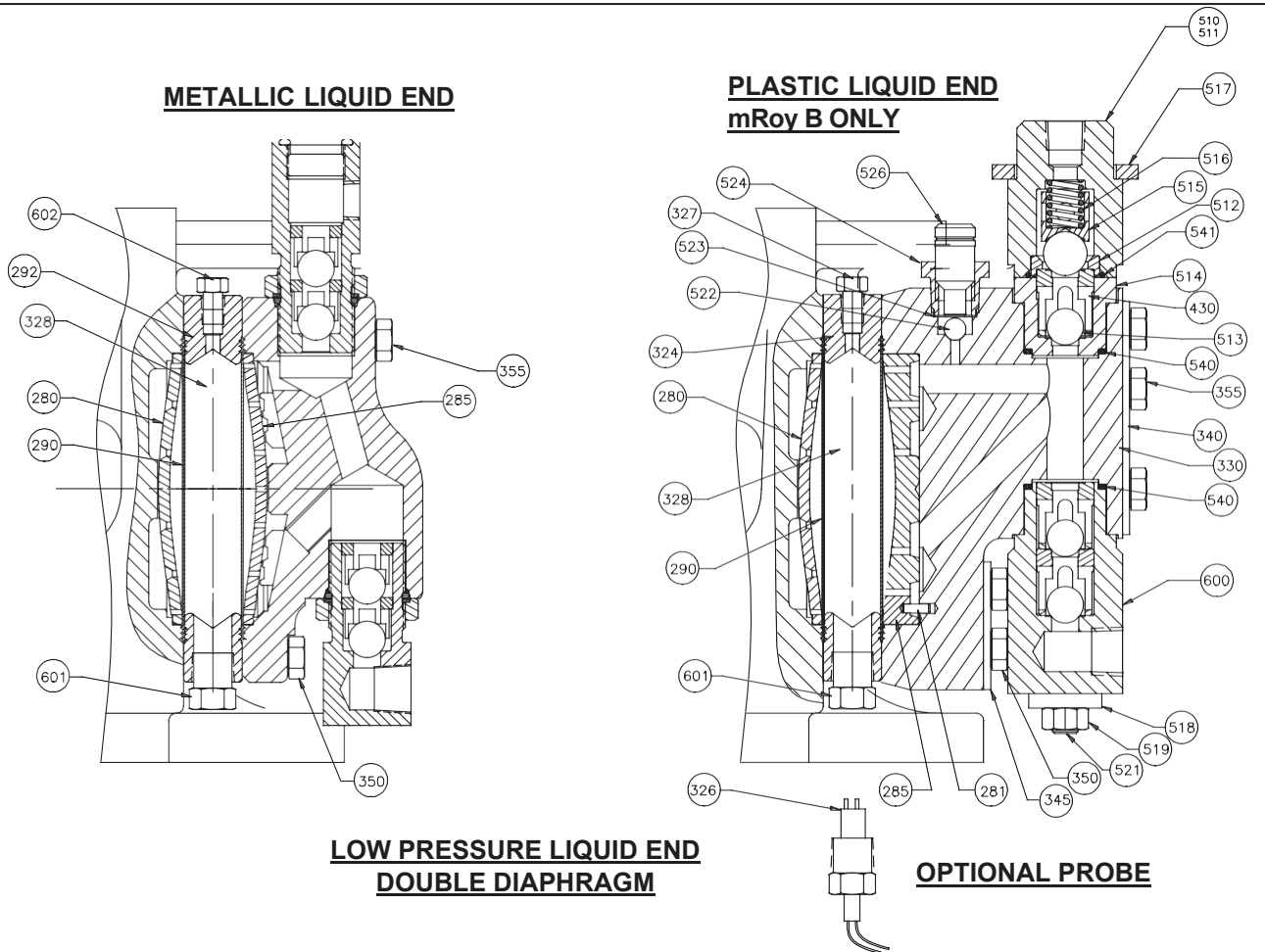


FIGURE 29. MROY B DOUBLE DIAPHRAGM (DWG 99920100025 & 99920100026)

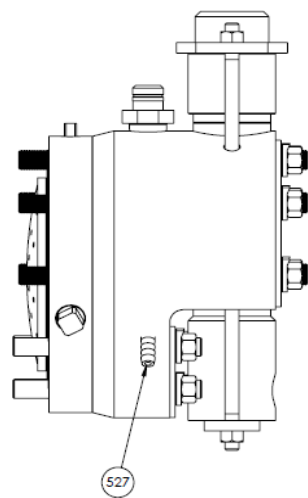


FIGURE 30. MROY B PLASTIC LIQUID END TUBE CONNECTOR DWG 99920100026)

6.17 mRoy B BASIC PARTS LIST FOR DRIVE MODELS (FIGURES 14 & 15)

DRAWING LOCATION NUMBER	DESCRIPTION	PART NUMBER	MATERIAL / SPM	QUANTITY
10	HOUSING, MAIN SIMPLEX 1/2" "H" PLUNGER	59499		
	HOUSING, MAIN SIMPLEX 19/32"	54076		1
	HOUSING, MAIN DUPLEX 19/32"	54074		1
	HOUSING, MAIN SIMPLEX 7/8"	54077		1
	HOUSING, MAIN DUPLEX 7/8"	54079		1
	HOUSING, MAIN SIMPLEX 1 7/16"	54078		1
	HOUSING, MAIN DUPLEX 1 7/16"	54080		1
20	CUP, RACE	4090066020	STEEL	1
30	POPPET, RELIEF VALVE	2120057074	NYLON	1
40	SPRING, RELIEF VALVE	2800046541	STEEL	1
50	ADJUSTING SCREW, RELIEF VALVE	2560037051	BRASS	1
60	PLUG - 1/4" NPT, SQ. HEAD	4020009111		1
90	PLUNGER, 19/32	22714		1
	PLUNGER, 7/8	22716		1
	PLUNGER, 1-7/16	22715		1
100	ROD, CONNECTING	2140013162	ALUMINUM	1
110	PIN, DOWEL 5/8X1-1/2	4010028031	STEEL	1
130	GEAR SHAFT	2680030006	SIMPLEX, STEEL	1
	GEAR SHAFT	2680022006	DUPLEX, STEEL	1
140	PLUG, 1-1/4 NPT, SOCKET HEX HEAD	4020095076	18-8SS	1
	PLUG, 1-1/4 NPT, SOCKET HEX HEAD	4020095077	ECOGUARD COAT. STL	1
	PLUG, 3/4 NPT, SOCKET HEX HEAD	4020095056	18-8SS	1
	PLUG, 3/4 NPT, SOCKET HEX HEAD	4020095057	ECOGUARD COAT. STL	1
150	O-RING, PARKER 2-113, CONTROL SPOOL	4080068032	URETHANE	1
160	CONTROL SPOOL	2680049006	STEEL	1
170	SLEEVE, THREADED, MROY B ECC	2430059051		1
180	SCREW, SOCKET SET, CUP PT. - 6-32NC X 1/4	4050039035		1
190	DECAL, CAPACITY	2530026062		1
200	RING, CALIBRATION	2530025062	ALUMINUM	1
210	KNOB, CONTROL	2550020062	ALUMINUM	1
220	E RING CLIP, EXTERNAL	4049983151		1
230	PLUNGER, CONTROL	2120048039		1
240	ARM, LINKAGE	2140014006		1
250	SCREW, SOCKET HEAD - 8-32NC X 1/2	4050245031	STEEL	2
1061	SCREW, SOCKET SET - 7/16-14 X 3/8	4050133024	STEEL	2
1062	SCREW, SOCKET HEAD - 8-32 X 1-5/8 (LOCKING MICROMETER)	40224	STEEL	1
1063	NUT, HEX - 8-32 NC 18-8SS (LOCKING MICROMETER)	4050061017	STEEL	1
1330	CAP, RESERVOIR SIMPLEX	43204570060N		1
	CAP, RESERVOIR DUPLEX	2810269000		1
1340	O-RING, PARKER - 2-216, SIMPLEX, RESERVOIR CAP	4080095071	BUNA	1
	O-RING PARKER - 2-216, DUPLEX, RESERVOIR CAP	4080095075	VITON	1
1350	SCREW PLUG - 7/8-14	4052001021	PLASTIC	1
-	PLATE, DATA	2530186000		1

SECTION 6 - PARTS

6.18 mRoy B LIQUID END – L & R FIGURE 24)

DRAWING LOCATION NUMBER	DESCRIPTION	PART NUMBER	MATERIAL / SPM	QUANTITY
280	CONTOUR PLATE - OIL SIDE	2980012006	STEEL	1
285	CONTOUR PLATE - PROCESS SIDE	2980016016	316 SS	1
		2980016028	ALLOY 20	1
		2980016030	ALLOY C-22	1
290	DIAPHRAGM - 5.230 DIA.	2980013075	PTFE	1
350	SCREW, HEX HEAD - 7/16-14 X 1-1/2 GR5	4050019149	STEEL	8
355	SCREW, HEX HEAD - 7/16-14 X 2-3/4	4050019191	STEEL	2
330	HEAD, DIAPHRAGM WITHOUT BLEEDER	59885	316 SS	1
		59886	ALLOY 20	1
	HEAD, DIAPHRAGM WITH BLEEDER	54184	316 SS	1
		54284	ALLOY 20	1
-	CONTOUR PLATE - PROCESS SIDE	2010395000		1
		2010428000		1
370	SCREW, HEX HEAD - 5/16-18 X 1-1/2 GR5	4050017149	STEEL	3
390	LOCK-WASHER, SPRING - 5/16	4040040028	ZINC PLATED	3
460	O-RING, DISCHARGE CHECK VALVE CAP	4080068113	PTFE	1
510	CHECK VALVE ASSEMBLY, DISCHARGE NPT	54345	316 SS	1
		54346	ALLOY 20	1
		54413	HAST C22	1
	CHECK VALVE ASSEMBLY, DISCHARGE BSP	54359	316 SS	1
		54360	ALLOY 20	1
		54415	HAST C-22	1
CHECK VALVE ASSEMBLY, DISCHARGE (SLURRY APPLICATIONS)	22077	316SS	1	
520	NUT, LOCK	2090021017	416 SS	1
530	BACK UP RING, SPIRAL	4080073221	PTFE	1
540	O-RING, CHECK VALVE LOCKING NUT - 3- 916, 1.171 X 0.116	4089998151	VITON	1
600	CHECK VALVE ASSEMBLY, SUCTION NPT	2210154016	316 SS	1
		2210154028	ALLOY 20	1
		30578	HAST C22	1
	CHECK VALVE ASSEMBLY, SUCTION BSP	54363	316 SS	1
		54366	ALLOY 20	1
		54417	HAST C-22	1
CHECK VALVE ASSEMBLY, SUCTION (SLURRY APPLICATION)	22078	316SS	1	

6.19 mRoy B LIQUID END – K (FIGURE 24)

DRAWING LOCATION NUMBER	DESCRIPTION	PART NUMBER	MATERIAL / SPM	QUANTITY
280	CONTOUR PLATE - OIL SIDE	2980014006	STEEL	1
285	CONTOUR PLATE - PROCESS SIDE	2980014006	STEEL	1
		2980014016	316 SS	1
		2980014028	ALLOY 20	1
		2980014030	ALLOY C-22	1
290	DIAPHRAGM - 3.390 DIA.	2980015075	PTFE	1
300	HEAD, DIAPHRAGM WITHOUT BLEEDER	59883	316 SS	1
		59884	ALLOY 20	1
	HEAD, DIAPHRAGM WITH BLEEDER	54186	316 SS	1
		54286	ALLOY 20	1
350	SCREW HEX HEAD - 7/16-14 X 1-1/2	4050019149	STEEL	4
355	SCREW HEX HEAD - 7/16-14 X 2-1/4	4050019171	STEEL	4
-	BASE, SIMPLEX	2010395000		1
	BASE, DUPLEX	2010428000		1
370	SCREW, HEX HEAD - 5/16-18 X 1-1/2 GR5	4050017149	STEEL	3
390	LOCK-WASHER, SPRING - 5/16	4040040028	ZINC PLATED	3
400	NUT, HEX - 5/16-18NC	4050065013	18-8 SS	3
460	O-RING, DISCHARGE CHECK VALVE CAP	4080068113	PTFE	1
510	CHECK VALVE, DISCHARGE	55022	316 SS	1
		55023	ALLOY 20	1
		55024	ALLOY C-22	1
520	NUT LOCK - CHECK VALVE	2090020014	303 SS	1
530	RING, SPIRAL BACK UP	4080073141	PTFE	1
540	O-RING, CHECK VALVE LOCK NUT - 2- 116,	4080068065	FKM (VITON)	1
600	CHECK VALVE, SUCTION	2210896216	316 SS	1
		2210896228	ALLOY 20	1
		2210896230	ALLOY C-22	1

6.20 mRoy B “H” (3000 PSI) SPECIFIC PARTS (FIG. 27 & 28)

DRAWING LOCATION NUMBER	DESCRIPTION	PART NUMBER	MATERIAL / SPM	QUANTITY
30	POPPET RELIEF VALVE – MRB 3000	59506	BRASS	1
40	COMP. SPRING 45.9MM X 14MM OD	59707	STEEL	1
50	SOC SET SCR CPT 5/8-18X5/8 STL	59507	STEEL	1
150	O-RING, 2-011, 90A DUROMETER	A51004	POLYURETHANE	3
280	CONTOUR PLATE 316SS MRB 3000	59503	316SS	2
290	DIAPHRAGM MRB 3000 GYLON .030	59513	GYLON	1
330	DIAPHRAGM HEAD MROY A NON-LD	59500	316SS	1
350	SCREW 3/8-16X3.25 SHCS ULTRA-COATED	41295	STEEL	12

6.21 mRoy B DIAPHRAGM HEAD DESIGN – “H” LEAK DET LIQUID END (FIGURE 28)

DRAWING LOCATION NUMBER	DESCRIPTION	PART NUMBER	MATERIAL / SPM	QUANTITY
195	O-RING 2-043 VITON 75 DURO	4080109405	VITON	1

SECTION 6 - PARTS

281	SPRING PIN 1/16 X 3/8 18-8 S/S	4010001041	18-8SS	3
280	CONTOUR PLATE 316SS MRB 3000	59503	316SS	2
286	SPACER RING MRB 3000 PSI	59505	316SS	1
287	INTERMEDIATE RING -A- 3000 MRB	59511	316SS	2
288	INTERMEDIATE RING -B- 3000 MRB	59512	316SS	2
290	DIAPHRAGM MRB 3000 GYLON .030	59513	GYLON	2
304	SPRING PIN 1/16 X 3/8 18-8 S/S	4010001041		3
330	DIAPH HEAD MRB 316 3000 PSI LD	59501	316SS	1
510	DISCH CART 316 2BALL ASSY PTFE	55022	316SS	1
520	LOCK NUT MPIF SS-303-R	2090020014	303 SS	2
530	BACK UP RING, TEFLON, SOLID	40321	PTFE	2
540	O-RING 2-116 VITON	4080068065	FKM (VITON)	2
600	SUCT CARTRIDGE DBL BALL 316/L	2210896216	316SS	1

6.22 mRoy B PLASTIC LIQUID END PARTS CONVERSION KIT (FIGURE 24)

Conversion Kit (P/N: PARTSKIT307) includes the following parts:

DRAWING LOCATION NUMBER	DESCRIPTION	PART NUMBER	MATERIAL / SPM	QUANTITY
280	CONTOUR PLATE - OIL SIDE	2980014006	STEEL	1
281	PIN, ORIENTATION	2110043071	PVC	1
285	CONTOUR PLATE	2980038071	PVC	1
290	DIAPHRAGM - 5.230 DIA.	2980013075	PTFE	1
330	HEAD, DIAPHRAGM	2210359071001	PVC	1

- Parts Not Illustrated

6.23 mRoy B PLASTIC LIQUID END PARTS (FIGURE 24)

DRAWING LOCATION NUMBER	DESCRIPTION	PART NUMBER	MATERIAL / SPM	QUANTITY
-	HEAD ASSEMBLY KIT, DIAPHRAGM (INCLUDES 330, 522, 523, 524, 526 AND 527)	2210393100		
340	REINFORCING PLATE, UPPER	2040088016	316SS	1
345	REINFORCING PLATE, LOWER	2040089016	316SS	1
350	SCREW, HEX HEAD - 7/16- 14 X 2-1/2	4050019187	18-8S	4
355	SCREW, HEX HEAD- 7/16-14 X 5	4050019297	18-8SS	6
-	BASE, SIMPLEX	2010395000		1
-	BASE, DUPLEX	2010428-000		1
510	CHECK VALVE ASSEMBLY, DISCHARGE (INCLUDES 430, 511, 512, 513, 514, 515, 516, AND 541)	2210464-007	PVC	1
		2210464009	PVDF	1
517	PLATE, COMPRESSION	2040091016	316SS	1
518	PLATE, COMPRESSION	2040090016	316SS	1
519	NUT, HEX- 5/16-18NC	4050065013	18-8SS	4
521	STUD- 5/16-18UNC X 10 1/4	2320014216	316SS	2
522	BALL - 3/8" DIA.	4070015111	CERAMIC AD995	1
523	DIAPHRAGM- 0.703 DIA.	2980062075	PTFE	1

SECTION 6 - PARTS

524	BUSHING- 1/2 NPT	2370049171	PVC	1
526	PLUG, PURGE	2430047171	PVC	1
527	CONNECTOR, (TUBING 1/4 X 1/4)	4020479028	PVC	1
540	O-RING, -3-916, 1.171 X0.116, CHECK VALVE	4089998151	FKM (VITON)	2
600	CHECK VALVE ASSEMBLY, SUCTION	2210360007	PVC / CERAMIC BALL	1
		2210360009	PVDF	1

6.24 mRoy B MOTOR MOUNTS (FIGURES 14 & 15)

Parts Common to All Motor Mounts

Worm and Shaft Assembly includes Stub Shaft (640), Worm (650), Spring Pin (660), Tapered Roller Bearing (670), and Single Roll Bearing (680).

DRAWING LOCATION NUMBER	DESCRIPTION	PART NUMBER		MATERIAL / SPM	QUANTITY
650	WORM, WORM GEAR, AND SHAFT ASSEMBLY	54703	38:1	48 SPM @1725 RPM	1
		54702	25:1	72 SPM @1725 RPM	1
		54701	19:1	96 SPM @1725 RPM	1
		54700	12.5:1	144 SPM @1725 RPM	1
		54699	9.5:1	148 SPM @1425 RPM	1
670	BEARING, TAPERED ROLLE	4090066010			1
680	BEARING, BALL	4099994000			1

SECTION 6 - PARTS

6.24 mRoy B MOTOR MOUNTS (FIGURES 14 & 15)

API Flange Mount NEMA 56C (FR)

DRAWING LOCATION NUMBER	DESCRIPTION	PART NUMBER	MATERIAL / SPM	QUANTITY
690	SEAL, OIL	4089997011		1
700	SPRING, FINGER	4030121009		1
690	SEAL, OIL	4089997011		1
700	SPRING, FINGER	4030121009		1
710	ADAPTER NEMA 56C- 143/145 TC	2720051001		1
770	SCREW, SOCKET HEAD - 10-32 X 3/4	4050026094	STEEL	2/4
780	COUPLING - 5/8 X 5/8, KEY 3/16	4100064020		1
790	SCREW, HEX HEAD- 3/8-16 X 1 GR5	4050018119	STEEL	1

API Flange Mount 143/145 TC

690	SEAL, OIL	4089997011		1
700	SPRING, FINGER	4030121009		1
710	ADAPTER NEMA 56C- 143/145 TC	2720051001		1
770	SCREW, SOCKET HEAD - 10-32 X 3/4	4050026094	STEEL	2/4
780	COUPLING - 5/8 X 7/8 3/16 KEY	4100064090		1

API Flange Mount IEC 80 B5

DRAWING LOCATION NUMBER	DESCRIPTION	PART NUMBER	MATERIAL / SPM	QUANTITY
690	SEAL, OIL	4089997011		1
700	SPRING, FINGER	4030121009		1
-	LOCK-WASHER, SPRING - 3/8"	4040041022	18-8 SS	1
-	NUT, HEX - 3/8-16NC	4050066012	18-8 SS	1
710	ADAPTER, MOTOR- IEC 80 85	60720388001		1
770	SCREW, SOCKET HEAD - 10-32 X 3/4	4050026094	STEEL	2/4
780	COUPLING ASSEMBLY- 5/8 X 19MM	39238		1
790	SCREW, HEX HEAD - 3/8-16 X 1-1/4	4050018136	ZINC PLATED	1

API Flange Mount IEC 90 B5

DRAWING LOCATION NUMBER	DESCRIPTION	PART NUMBER	MATERIAL / SPM	QUANTITY
690	SEAL, OIL	4089997011		1
700	SPRING, FINGER	4030121009		1
-	LOCK-WASHER, SPRING - 3/8"	4040041022	18-8 SS	4
-	NUT, HEX - 3/8-16NC	4050066012	18-8 SS	4
710	ADAPTER, MOTOR- IEC 80 85	60720388001		1
780	COUPLING ASSEMBLY- 5/8 X 24MM	30459		1
790	SCREW, HEX HEAD - 3/8-16 X 1-1/4	4050018136	ZINC PLATED	4

- Parts Not Illustrated

6.25 mRoy B ACTUATED CAPACITY CONTROL MOUNTING (FIGURE 23)

DRAWING LOCATION NUMBER	DESCRIPTION	PART NUMBER	MATERIAL / SPM	QUANTITY
140	ADAPTER PLUG 3/4 NPT	2430045010 (K)	316SS	1
	ADAPTER PLUG 1-1/4 NPT	2430045030 (L&R)		1
150	O-RING PARKER 2-113 URETHANE	4080068032	URETHANE	3
160	CONTROL SPOOL 304/316SS	2680049006	304/316SS	1
170	THD SLEEVE SPEC FIN MROY B ECC	2430059051	BRASS	1
180	SOC SET SCR CPT 6-32NCX1/4	4050039035	18-8SS	1
190	DECAL CAPACITY	2530026062	ALUMINUM	1
200	CALIBRATION RING ALUMINUM	2530025062	ALUMINUM	1
210	CAPACITY ADJUST KNOB DELRIN	2550036077	DELRIN	1
213	CONTROL SPOOL BEARING ECC	2370075052	BRONZE	1
217	THRUST WASHER 1/2 STEEL	4040147051	STEEL	1
220	1/2 BOWED E-RING CLIP EXTERN	4049983151	STEEL	1
221	SHIM FASTENAL NUMBER 7041808	55916	STEEL	1
810	DRIVE COUPLING ECC	2520120077	DELRIN	1
820	INT TOOTH LOCK WASH #8 ZC PL	4040104082	STEEL	2
830	PAN HD SCR #8-32NCX1/2 18.8SS	4050179073	18-8SS	2
840	MROY B ACC BRACKET BERNARD	58785	STEEL	1
860	SERR FLANGE NUT 1/4-20NC Z PLT	4050323036	STEEL	1
880	SOC HD SCR 5/16-18X5/8 STL NYL	4050157024	STEEL	1
900	ACTUATOR (MROY)	PER SPEC		1
910	DRIVE SHAFT DELRIN 150 ECC	2680053077	DELRIN	1
915	DOWEL PIN 1/8X1-3/8 STEEL RC60	4010021143	STEEL	1
920	SPRING PIN 3/16 X 13/16 420SS	4010005062	420SS	1
930	LOCK WASHER, M8,316SS	52957	316SS	4
935	ECOGUARD SHCS M8X20 CLASS 12.9	57109	STEEL	4
936	ECC BERNARD SPLINE SHAFT	56864	304SS	1
937	SHAFT RETAINER RING D28	4340065001N	STEEL	1
950	SIDE GUARDS ECC	2490108006	STEEL	2
970	BTN HD SC SCR #10-32X5/16 18-8	4050282087	18-8SS	4
1440	MROY ECC INSTRUCTION MANUAL	3390083000		1

SECTION 6 - PARTS

6.26 mRoy B SIMPLEX LEAK DETECTION PARTS- GAUGE & NEMA SWITCH (FIGURE 25)

Double Quantities for Duplex Pumps

DRAWING LOCATION NUMBER	DESCRIPTION	PART NUMBER	MATERIAL / SPM	QUANTITY
290	DIAPHRAGM, 5.230 DIA.	2980013075	PTFE	2
	DIAPHRAGM, 3.390 DIA., K PLUNGER	2980015075	PTFE	2
300	RING ASSEMBLY, INTERMEDIATE	2190089116	316 SS	1
	RING ASSEMBLY, INTERMEDIATE K PLUNGER	1791260116	316 SS	1

6.27 mRoy B DOUBLE DIAPHRAGM PARTS FOR METALLIC LIQUID END (FIGURE 26)

DRAWING LOCATION NUMBER	DESCRIPTION	PART NUMBER	MATERIAL / SPM	QUANTITY
280	CONTOUR PLATE - OIL SIDE	2980012006		
285	CONTOUR PLATE - PROCESS SIDE	2980016016	316 SS	1
		2980016028	ALLOY 20	1
		2980016030	ALLOY C-22	1
290	DIAPHRAGM - 5.230 DIA.	2980013075	PTFE	2
292	INTERMEDIATE CHAMBER	20539	316 SS	1
328	OIL, VEGETABLE	40104		105-115 ML (3.6-3.9 OZ)
350	SCREW, HEX HEAD- 7/16-14 X 2 1/2	4050019181	STEEL	8
355	SCREW, HEX HEAD- 7/16-14 X 3 3/4	40894	STEEL	2
601	PLUG, PIPE- 3/8" THREADED	4020011033	316 SS	1
602	PLUG, PIPE- 1/8" THREADED	4020011013	316 SS	1

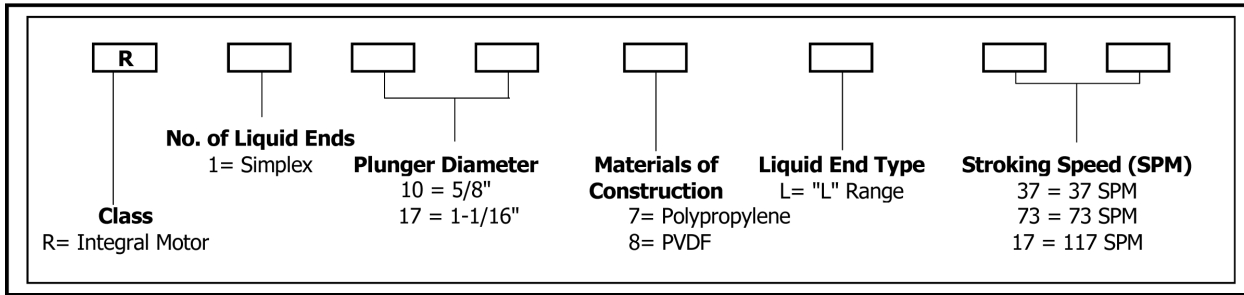
6.28 mRoy B DOUBLE DIAPHRAGM PARTS- WITH CONDUCTIVITY PROBE FOR PLASTIC LIQUID END (FIGURE 26 & 27)

DRAWING LOCATION NUMBER	DESCRIPTION	PART NUMBER	MATERIAL / SPM	QUANTITY
290	DIAPHRAGM 5.230 DIA.	298-0013-075	PTFE	2
324	INTERMEDIATE CHAMBER	20539	316 SS	1
326	PROBE, ALARM CONDUCTIVITY	3010307000		1
	PLUG, PIPE- 3/8", USED WITHOUT ALARM PROBE	4020011033	316SS	1
327	PLUG, PIPE- 1/8" THREADED	4020011013	316 SS	1
328	OIL, VEGETABLE	40104		105-115 ML (3.6-3.9 OZ)
350	SCREW, HEX HEAD- 7/16-14 X 3 1/2	40448	18-8 SS	4
355	SCREW, HEX HEAD- 7/16-14 X 6	40447	18-8 SS	6
527	CONNECTOR, TUBING 1/4" OD X 1/4"	4020479028	POLYETHYLENE	1

- Parts Not Illustrated

1.1 APPENDIX A
1.2 MODEL CODE HISTORY
(PRIOR TO 2016)

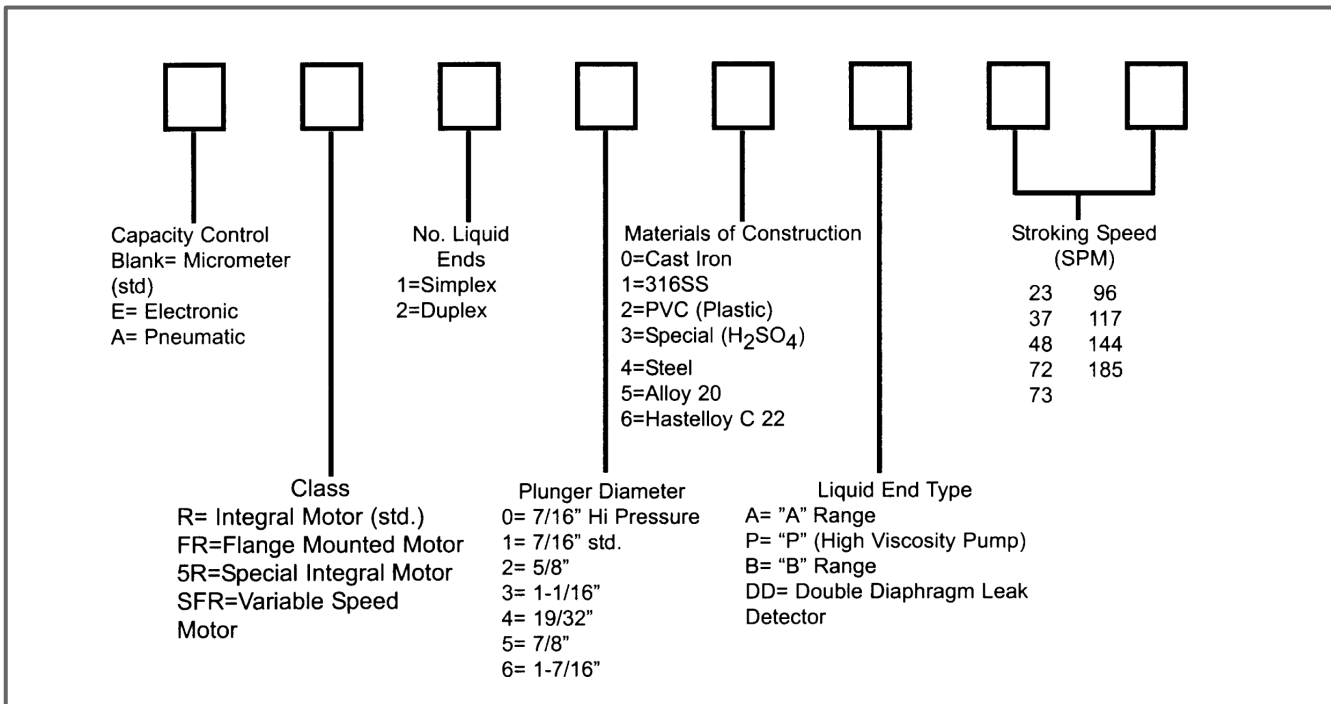
mRoy L History



PUMP SPECIFICATIONS (mRoy L) :

- Liquid End: Hydraulically actuated, simplex only
- Plunger Diameter: 5/8" or 1-1/16"
- Capacity Range: 0.2 GPH to 18 GPH (0.752 LPH to 68 LPH)

mRoy A History



MODEL CODE SELECTION
END ITEM OPTION SELECT NUMBER

mRoy A SERIES

End item Model Code			Option Selected Number									
R	A	1*		-								
Material Code		Plunger Diameter	Gear Set	Mount / Motor	Suction Connection	Discharge Connection	Capacity Control	Rupture Detection & Base				

* 2 for Duplex

mRoy A LIQUID END MATERIAL CODE SELECTION

Code	Description
0	Cast Iron
1	316 SS (STANDARD)
2	PVC (N/A with 9.5 :1 Gear Ratio)
7	PVDF (N/A with 9.5 :1 Gear Ratio)
5	Alloy 20
6	Alloy C22

mRoy A PLUNGER DIAMETER

Code	Description
7	7/16" Diameter
10	5/8 " Diameter
17	1-1/16" Diameter

mRoy H/T SERIES

RH= 7/16" Dia. Plunger

RT= 3/8" Dia. Plunger

End item Model Code			Option Selected Number							
R	H	1		-						
Material Code		Gear Set	Mount / Motor	Suction Connection	Discharge Connection	Capacity Control	Base			

mRoy H LIQUID END MATERIAL

Code	Description
0	Cast Iron
1	316 SS (STANDARD)
5	Alloy 20

mRoy J SERIES

End item Model Code			Option Selected Number						
R	J	1		-					
Material Code		Gear Set	Mount / Motor	Suction Connection	Discharge Connection	Capacity Control	Rupture Detection & Base		

mRoy J LIQUID END MATERIAL

Code	Description
1	316 SS (STANDARD)
5	Alloy 20

mRoy P SERIES

End item Model Code			Option Selected Number						
R	P	1		-					
Material Code		Plunger Diameter	Gear Set	Mount / Motor	Suction Connection	Discharge Connection	Capacity Control	Rupture Detection & Base	

mRoy P LIQUID END MATERIAL

Code	Description
0	Cast Iron
1	316 SS (STANDARD)
5	Alloy 20

mRoy P PLUNGER DIAMETER

Code	Description
7	7/16" Diameter
10	5/8 " Diameter
17	1-1/16" Diameter

MROY A, H, T, J AND P MODEL CODE

GEAR SET (ALL mRoy A FRAME)

Code	Description	1725 rpm	1425 rpm	1140 rpm	
77	77 : 1 Gear Ratio	N/ A for mRoy J or P	23 spm	19 spm	15 spm
48	48 : 1 Gear Ratio		37 spm	30 spm	24 spm
24	24 : 1 Gear Ratio		73 spm	60 spm	47 spm
15	15 : 1 Gear Ratio		117 spm	96 spm	76 spm
10	9.5 : 1 Gear Ratio	N/ A for mRoy J or P	185 spm	152 spm	120 spm

MOTORS and MOUNTS

STANDARD MOTOR with Close Coupled Flange

Code	Description
A1	1/4 HP Motor, TE, 1725 RPM, 1 phase, 60 Hertz, 115 Volt & Close Coupled Flange
A8	1/4 HP Motor, TE, 1725 RPM, 3 phase, 60 Hertz, 230/460 Volt & Close Coupled Flange

Does not require motor mount from below

NOTE: These motors replace the obsolete integral motor offering. They are standard NEMA 56 C frame motor on a short flange

MOTOR MOUNTS (Use only when motor is ordered from Milton Roy)

Code	Description
SR	Close Coupled Flange, NEMA 56C (STANDARD)
SS	Close Coupled Flange, IEC Frame 71, B5 Flange
FR	API Flange Mount, NEMA 56C
F4	API Flange Mount, NEMA 143TC/145 TC
FS	API Flange Mount, IEC Frame 71, B5 Flange
MD	API Flange Mount, IEC Frame 80, B5 Flange

1/4 HP minimum

Motor supplied by Milton Roy from Accessory Section

MOTOR MOUNTS

Code	Description
1X	Close Coupled Flange, NEMA 56C
2X	Close Coupled Flange, IEC Frame 71, B5 Flange
3X	API Flange Mount, NEMA 56C
4X	API Flange Mount, NEMA 143TC/ 145TC
5X	API Flange Mount, IEC Frame 71, B5 Flange
6X	API Flange Mount, IEC Frame 80, B5 Flange

1/4 HP minimum

Motor supplied by others

NOTE: Must be used when pump is not ordered with motor

SUCTION CONNECTION

Metallic Liquid Ends

Code	Description	PVC	316 SS	Alloy 20
SE	NPT 1/2" Female (STANDARD)	N/A	Standard	Standard
T1	ANSI 150 # RF 1/2" Threaded	N/A		
T3	ANSI 300 # RF 1/2" Threaded	N/A		
S1	ANSI 150 # RF 1/2" Socket Welded	N/A		
S3	ANSI 300 # RF 1/2" Socket Welded	N/A		

Plastic Liquid Ends

Code	Description	PVC	316 SS	Alloy 20
SE	NPT 1/2" Male (STANDARD)	Standard	N/A	N/A
T1	150 # 1/2" Thd flange		N/A	N/A

NOTES:

1. Base option recommended with flanged connections.
2. Flanges can only be welded at flanged end.

DISCHARGE CONNECTION

Codes and prices are the same as Suction Connection

Discharge connections size for SE code on metallic liquid ends is 1/4" NPT

CAPACITY CONTROL

Code	Description
M2	Manual Micrometer Knob - PVC (STANDARD)
M1	Manual Micrometer Knob - 316 SS
ML	Locking Manual Micrometer Knob - 316 SS
E1	Electronic - NEMA 4, 4-20 mA, 115 Volt
E2	Electronic - NEMA 4, 4-20 mA, 220 Volt
EA	Electronic - Explosion Proof, 4-20 mA, 115 Volt
EB	Electronic - Explosion Proof, 4-20 mA, 220 Volt
EE	Mount for Electronic, Less Actuator
PN	Pneumatic, 3-15 psi, Direct Acting

**MROY A, H, T, J AND P GEAR/MOTOR MOUNT / CONNECTION / CAPACITY CONTROL.
SELECT MODE CODE**

MODEL CODE SELECTION END ITEM OPTION SELECT NUMBER

mRoy B SERIES

End Item Model Code	Option Selected Number																														
<table border="1" style="width: 100%; border-collapse: collapse;"> <tr> <td style="width: 20px; text-align: center;">R</td> <td style="width: 20px; text-align: center;">4*</td> <td style="width: 20px; text-align: center;"> </td> <td style="width: 20px; text-align: center;"> </td> <td style="width: 20px; text-align: center;"> </td> <td style="width: 20px; text-align: center;"> </td> <td style="width: 20px; text-align: center;"> </td> <td style="width: 20px; text-align: center;"> </td> <td style="width: 20px; text-align: center;"> </td> <td style="width: 20px; text-align: center;"> </td> </tr> <tr> <td style="font-size: 8px;">Plunger Diameter</td> <td style="font-size: 8px;">Liquid End Material</td> <td style="font-size: 8px;">Gear Set</td> <td style="font-size: 8px;">Motor Mount</td> <td style="font-size: 8px;">Suction Connection</td> <td style="font-size: 8px;">Discharge Connection</td> <td style="font-size: 8px;">Capacity Control</td> <td style="font-size: 8px;">Rupture Detection & Base</td> <td style="font-size: 8px;"> </td> <td style="font-size: 8px;"> </td> </tr> </table>	R	4*									Plunger Diameter	Liquid End Material	Gear Set	Motor Mount	Suction Connection	Discharge Connection	Capacity Control	Rupture Detection & Base			<table border="1" style="width: 100%; border-collapse: collapse;"> <tr> <td style="width: 20px; text-align: center;"> </td> <td style="width: 20px; text-align: center;"> </td> <td style="width: 20px; text-align: center;"> </td> <td style="width: 20px; text-align: center;"> </td> <td style="width: 20px; text-align: center;"> </td> <td style="width: 20px; text-align: center;"> </td> <td style="width: 20px; text-align: center;"> </td> <td style="width: 20px; text-align: center;"> </td> <td style="width: 20px; text-align: center;"> </td> <td style="width: 20px; text-align: center;"> </td> </tr> </table>										
R	4*																														
Plunger Diameter	Liquid End Material	Gear Set	Motor Mount	Suction Connection	Discharge Connection	Capacity Control	Rupture Detection & Base																								

* 2 for Duplex

PLUNGER DIAMETER

Code	Description
S	19/32" Diameter
M	7/8" Diameter
B	1-7/16" Diameter

LIQUID END MATERIAL

Code	Description
1	316 SS (STANDARD)
2	PVC (not available with plunger code "5")
5	Alloy 20
7	PVDF (Plunger code "B" only)

GEAR SET

Code	Description	1725 rpm	1425 rpm	1140 rpm
38	38 : 1 Gear Ratio	48 spm	40 spm	31 spm
25	25 : 1 Gear Ratio	72 spm	60 spm	48 spm
19	19 : 1 Gear Ratio	96 spm	80 spm	62 spm
12	12 : 1 Gear Ratio	144 spm	120 spm	95 spm
10	10 : 1 Gear Ratio	N/A	148 spm	N/A

MOTOR MOUNTS

MOTOR MOUNT (Use only when motor is ordered from Milton Roy - see section 4100)

Refer to capacity/ pressure table for horsepower required

Code	Description
FR	API Flange Mount, NEMA 56C
F4	API Flange Mount, NEMA 143TC/145TC
F8	API Flange Mount, IEC Frame 80, B5 Flange
F9	API Flange Mount, IEC Frame 90, B5 Flange

Motor supplied by Milton Roy from Accessory Section

MOTOR MOUNTS

Refer to capacity/ pressure table for horsepower required

Code	Description
3X	API Flange Mount, NEMA 56C
4X	API Flange Mount, NEMA 143TC/145TC
5X	API Flange Mount, IEC Frame 80, B5 Flange
6X	API Flange Mount, IEC Frame 90, B5 Flange

NOTE: Must be used when pump is not ordered with motor (to cover added cost of testing)

SUCTION CONNECTION

Metallic Liquid Ends

Code	Description	PVC	316 SS	Alloy 20
SE	NPT 1/2" Female (STANDARD)	N/A	Standard	Standard
T1	ANSI 150 # RF 1/2" Threaded	N/A		
T3	ANSI 300 # RF 1/2" Threaded	N/A		
S1	ANSI 150 # RF 1/2" Socket Welded	N/A		
S3	ANSI 300 # RF 1/2" Socket Welded	N/A		

Plastic Liquid Ends

Code	Description	PVC	316 SS	Alloy 20
SE	NPT 1/2" Male (STANDARD)			
T1	150 # 1/2" Thd flange			

NOTES:

1. Base option recommended with flanged connections.
2. Flanges can only be welded at flanged end.

DISCHARGE CONNECTION

Same codes and prices as Suction Connection

NOTE: Connection sizes for SE code metallic are 3/8" NPT on mRoy M & B series, and NPT on mRoy S series

CAPACITY CONTROL

Code	Description	
AL	Manual Micrometer Knob - Aluminium (STANDARD)	
ML	Manual Micrometer Locking Knob - 316 SS	
E1	Electronic - NEMA 4, 4-20 mA, 115 Volt	Remember to derate pump
E2	Electronic - NEMA 4, 4-20 mA, 220 Volt	Remember to derate pump
EA	Electronic - Explosion Proof, 4-20 mA, 115 Volt	Remember to derate pump
EB	Electronic - Explosion Proof, 4-20 mA, 220 Volt	Remember to derate pump
EE	Mount for Electronic, Less Actuator	
PN	Pneumatic, 3-15 psi, Direct Acting	Remember to derate pump

RUPTURE DETECTION & BASE

All Liquid Ends

Code	Description	
NN	None (STANDARD)	Standard
NB	Base	

Metallic Liquid Ends Only

Code	Description	
C5	Rupture Detection with & Gauge	Remember to derate pump
SN	Rupture Detection W/Gauge, & NEMA 4 Switch	Remember to derate pump
S7	Rupture Detection W/Gauge, & Exp. Prf 5 Switch	Remember to derate pump

Plastic Liquid End Only

Code	Description	
DD	Double Diaphragm	Remember to derate pump
DP	Double Diaphragm w/Conductivity probe Relay supplied separately - see accessory pricing	Remember to derate pump

MROY B MODEL CODE

