

SALES & ENGINEERING DATA

RATIO SERIES: 1:1

FLUID PSIG RANGE: 20 - 120

PM30R-CSS-XXX-C02 3" METALLIC DIAPHRAGM PUMP

RELEASED: 2-16-05
REVISED: 9-23-15
(REV. F) S-1347

DIMENSIONAL DATA

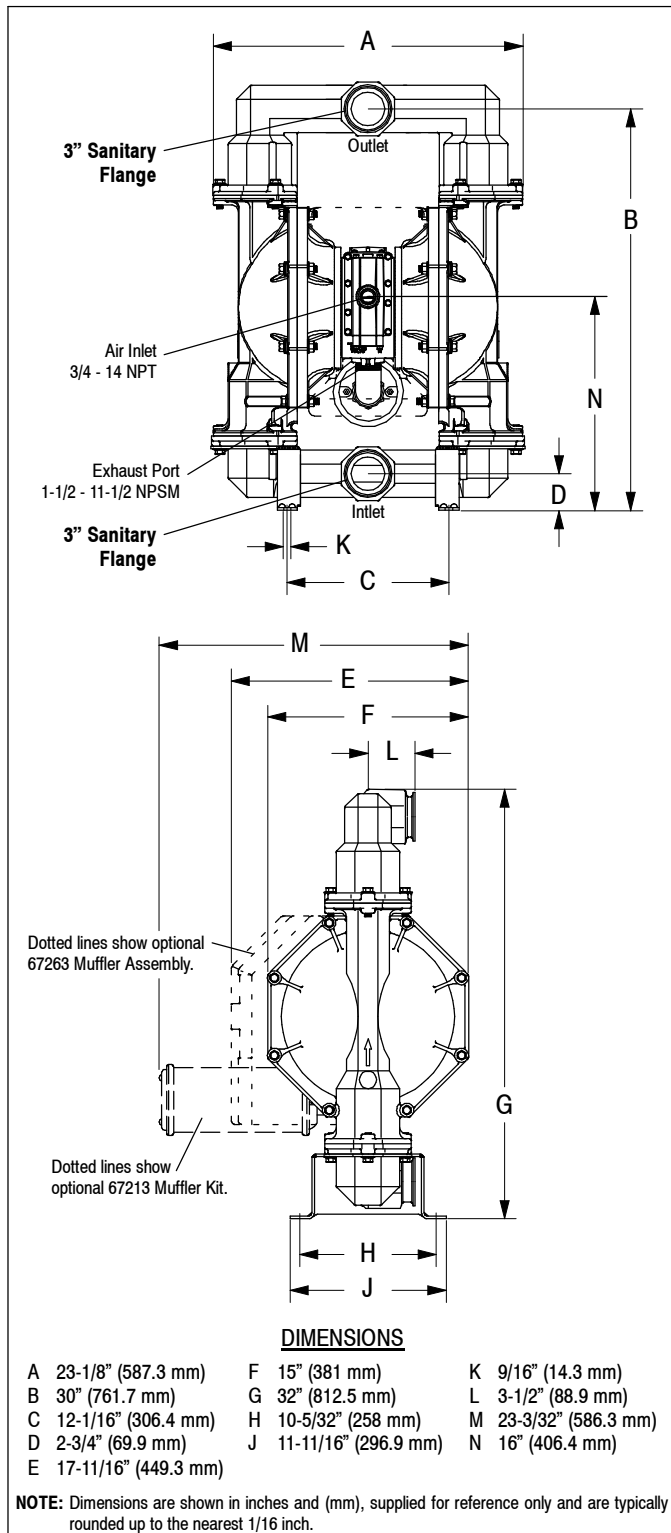

SPECIFICATIONS

CONSTRUCTION

Model Series	PM30R-CSS-XXX-C02
Pump Type	Metallic, Air Operated, Double Diaphragm
Ratio	1:1
Material Inlet / Outlet	3" Sanitary Flange
Air Inlet (female)	3/4 - 14 NPTF
Air Exhaust (female)	1-1/2 - 11-1/2 NPSM
Weight	253.3 lbs (114.9 kgs)
Air Section Service Kit	637369
Major Air Valve Assembly	637374
Fluid Section Service Kit	637303-XX

PM30R-CSS- X X X -C02
637303 - X X
 Diaphragm Material
 Ball Material

EXAMPLE: Model #PM30R-CSS-SAA-C02
 Fluid Section Service Kit is 637303-AA

PERFORMANCE

Air Inlet Pressure Range	20 - 120 psig (1.4 - 8.3 bar)
Maximum Material Inlet Pressure	10 psig (0.69 bar)
Fluid Outlet Pressure Range	20 - 120 psig (1.4 - 8.3 bar)
Maximum Flow Rate	237 gpm (897 lpm)
flooded inlet	275 gpm (1,041 lpm)
Maximum Particle Size	3/8" dia. (9.5 mm)
Maximum Temperature Limits (diaphragm / ball / seal material)	
E.P.R.	-60° to 280° F (-51° to 138° C)
Nitrile	10° to 180° F (-12° to 82° C)
Polypropylene	35° to 175° F (2° to 79° C)
Santoprene	-40° to 225° F (-40° to 107° C)
PTFE	40° to 225° F (4° to 107° C)
Displacement / Cycle @ 100 psig	2.8 gal. (10.6 lit.)
Noise Level @ 70 psig - 50 cpm ^①	83.0 dB(A) ^②

Notes:

- ① Tested with 67263 muffler assembly installed.
- ② The pump sound pressure level has been updated to an Equivalent Continuous Sound Level (L_{Aeq}) to meet the intent of ANSI S1. 13-1971, CAGI-PNEUROP S5.1 using four microphone locations.

ACCESSORIES:

- 66109 Air Line Connection Kit
- 67213 Muffler Kit
- 67263 Continuous Muffler
- 94117 Int. Muffler



Illinois Location:

(847) 841-7867
 860 Church Rd Elgin, IL 60123

Minnesota Location:

(651) 758-7867
 330 Mill Bay South Suite 1511 Afton, MN 55001

PumpSupplyInc.com



PERFORMANCE CURVES

PM30R-CSS-XXX-C02 3" METALLIC DIAPHRAGM PUMP

