



# ULTRACHem<sup>®</sup> Series

ANSI DIMENSIONAL MAG DRIVE

UCR2110, UCR2110L, UCR3110, UCR3158, UCR328, UCR3210,  
UCR436, UCR438, UCR4310H, & UCR6410

## OPERATIONAL MANUAL

### P/N 212181 R1

Record your Model and Serial Number here.

MODEL NUMBER \_\_\_\_\_

SERIAL NUMBER \_\_\_\_\_

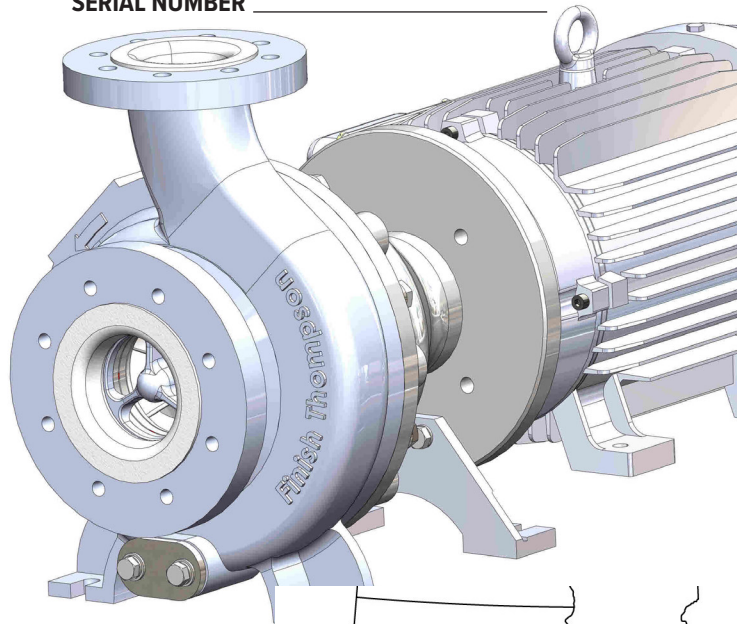



**FINISH THOMPSON INC.**  
921 Greengarden Road • Erie, PA 16501-1591 U.S.A.  
Ph 814-455-4478 • Fax 814-455-8518  
Email [fti@finishthompson.com](mailto:fti@finishthompson.com) • [www.finishthompson.com](http://www.finishthompson.com)

## EU Declaration of Conformity



Finish Thompson Inc. hereby declares that the following machine(s) fully comply with the applicable health and safety requirements as specified by the EU Directives listed. The product may not be taken into service until it has been established that the drive motor for the centrifugal pump complies with the provisions of all relevant EU Directives. The complete product complies with the provisions of the EU Directive on machinery safety provided motors carry CE marking.

This declaration is valid provided that the devices are fully assembled and no modifications are made to these devices.

**Type of Device:**  
Centrifugal Pumps

**Models:**  
**UC** 1516/1516L/1518/1518L/2110/2110L/3110/3156/3158/326/326H/436/436L/438/4310H/6410  
**UCR** 1516/1516L/1518/1518L/2110/2110L/3110/3156/3158/326/326H/436/436L/438/4310H/6410  
**UCP** 1516/1516L/1518/1518L/3156/326/326H/436L

**EU Directives:**  
Machinery Safety (2006/42/EC)

**Applied Harmonized Standards:**  
EN ISO 12100:2010  
EN 809:1998+A1:2009+AC:2010

Manufacturer: Finish Thompson Inc.  
921 Greengarden Road  
Erie, Pennsylvania 16501-1591 U.S.A

Signed,

Product Engineering Manager

31 December 2024

Person(s) Authorized to Compile Technical File: Finish Thompson GmbH  
Otto-Hahn-Strasse 16  
Maintal, D-63477 DEU Telephone:  
49 (0)6181-90878-0

# EU Declaration of Conformity

Manufactured by:

Finish Thompson, Inc.  
 921 Greengarden Road  
 Erie, Pennsylvania 16501 U.S.A.  
 Phone: 1-(814)-455-4478  
 Fax 1-(814)-455-8518  
 Email: [fti@finishthompson.com](mailto:fti@finishthompson.com)  
 Web: [www.finishthompson.com](http://www.finishthompson.com)





**1026**

**II 2GD**  
**Ex h IIB T6...T4 Gb**  
**Ex h IIIC T6...T4 Db**  
**FTZU 03 ATEX A049-03**  
**FTZU 25 ATEX A900-25**

Finish Thompson declares under our sole responsibility that the product listed below conforms to the relevant provisions of EU directive 2014/34/EU of 26 February 2014 for equipment and protective systems intended for use in potentially explosive atmospheres, and is certified for safe use in Atmosphere Group IIB/IIIC category 2 areas.

This declaration applies to Finish Thompson, Inc. ATEX UC Series pumps with the brass bump ring designated by the letter "B" after the motor adapter in the model number. Pumps and their model number may also contain many different combinations of magnet sets, flange port connections, coupling type, bushings, shafts, o-rings, impellers, motor adapters and other options.

Models: UC1516"B", UC1516L"B", UC1518"B", UC1518L"B", UC326"B", UC326H"B", UC3156"B", UC436L"B", 2110"B", 2110L"B", 3110"B", 3110L"B", 3158"B", 3158L"B", 3210"B", 328"B", 436"B", 438"B", 4310H"B", 6410"B", 648"B", 4310"B"

UCR1516"B", UCR1516L"B", UCR1518"B", UCR1518L"B", UCR326"B", UCR326H"B", UCR3156"B", UCR436L"B", UCR 2110"B", UCR2110L"B", UCR3110"B", UCR3110L"B", UCR3158"B", UCR3158L"B", UCR3210"B", UCR328"B", UCR436"B", UCR438"B", UCR4310H"B", UCR6410"B", UCR648"B", UCR4310"B"

NOTE: UCP models are NOT ATEX rated.

Model Number Breakdown (See instruction manual):

UCX	XXXX	-	X	-	X	-	X	-	X	-	X	-	XXX	-	XX	-	B	-	XX				
SERIES	BASE MODEL		MAGNET SET		FLANGE		COUPLING TYPE		BUSHING		SHAFT		O-RING		THRUST RING		IMPELLER		MOTOR ADAPTER		BUMP RING ATEX ONLY		MOTOR

This product has used the following designated standards to verify conformance:

Non-electrical equipment for potentially explosive atmospheres: EN ISO 80079-36:2016 Basic Methods and Requirements.

Non-electrical equipment intended for use in potentially explosive atmospheres: EN80079-37 Protection by construction safety "ch" and control of ignition source "bh".

**This product must not be used in areas other than specified above. If in doubt consult an authorized distributor, or refer to the manufacturer Finish Thompson.**

Approved by:  Date: 12/31/2024

## Table of Contents

Warranty Statement .....	5
Safety Precautions .....	5
ATEX Safety Precautions .....	6
Surface Temperature for ATEX Pumps .....	6
ULTRAChem Features .....	7
ULTRAChem Capabilities.....	7
Maximum Allowable Horsepower.....	7
Minimum Allowable Flow Rate .....	8
Model Codes and Abbrevians .....	8
Unpacking and Inspection.....	9
Model Number and Serial Number.....	9
<b>Installation</b>	
Pumps with Motors .....	9
Pumps without Motors .....	9-10
Foundation .....	11
Baseplate .....	11
Piping.....	11-12
Electrical .....	12
<b>Operation</b>	
Pre-operation Inspection.....	12
Start-up and Operation.....	12-13
Shutdown.....	13
<b>Disassembly/Reassembly</b>	
Disassembly of Pump End .....	13-14
Disassembly of Power End (Motor Side) .....	14
Examination .....	15
Replacing Wear Components .....	16
Shaft Support/Front Thrust Washer .....	16
Impeller Thrust Ring .....	16
Rear Sealing Ring .....	17
Impeller Assembly Removal and Replacement.....	18-19
Impeller Bushings.....	20
Power End Reassembly .....	20
Pump End Reassembly .....	20-21
Troubleshooting .....	22
<b>General Notes</b>	
Important Notice .....	22
Chemical Reaction Disclaimer.....	22
Helpful Hints .....	22
Ordering Spare Parts .....	22
Exploded View Drawing .....	23
Parts List .....	24-29
Impeller Part Numbers .....	30-31



## WARRANTY

Finish Thompson, Inc. (manufacturer) warrants this pump product to be free of defects in materials and workmanship for a period of **two years** from date of purchase by original purchaser. If a warranted defect, which is determined by manufacturer's inspection, occurs within this period, it will be repaired or replaced at the manufacturer's option, provided (1) the product is submitted with proof of purchase date and (2) transportation charges are prepaid to the manufacturer. Liability under this warranty is expressly limited to repairing or replacing the product or parts thereof and is in lieu of any other warranties, either expressed or implied. This warranty does apply only to normal wear of the product or components. This warranty does not apply to products or parts broken due to, in whole or in part, accident, overload, abuse, chemical attack, tampering, or alteration. The warranty does not apply to any other equipment used or purchased in combination with this product. The manufacturer accepts no responsibility for product damage or personal injuries sustained when the product is modified in any way. If this warranty does not apply, the purchaser shall bear all cost for labor, material and transportation.

Manufacturer shall not be liable for incidental or consequential damages including, but not limited to process down time, transportation costs, costs associated with replacement or substitution products, labor costs, product installation or removal costs, or loss of profit. In any and all events, manufacturer's liability shall not exceed the purchase price of the product and/or accessories.

### Warranty Registration

Thank you for your purchase of this quality Finish Thompson product. Be sure to take a minute to register your pump at [Finishthompson.com/warranty](http://Finishthompson.com/warranty). Simply provide the model number, serial number and a few other pieces of information.

## SAFETY PRECAUTIONS

- ⚠ WARNING: READ THIS MANUAL COMPLETELY BEFORE INSTALLING AND OPERATING THIS UNIT. FAILURE TO FOLLOW THESE PRECAUTIONS CAN RESULT IN SERIOUS INJURY OR DEATH.**
- ⚠ WARNING: Magnetic force hazard.** This pump should only be disassembled and assembled using the recommended procedures. The magnetic attraction is powerful enough to rapidly pull the motor end and the wet end together. **ALWAYS** use the jackscrews (item 14) to assemble/disassemble the pump. Do not place fingers between the mating surfaces of the motor and wet ends to avoid injuries. Keep the drive magnet and impeller assembly away from metal chips or particles.
- ⚠ WARNING: Magnetic Field Hazard.** This pump contains powerful rare earth magnets. When the pump is disassembled (not connected to a motor) and the magnets are exposed, these magnets produce powerful magnetic fields. Individuals with cardiac pacemakers, implanted defibrillators, other electronic medical devices, metallic prosthetic heart valves, internal wound clips (from surgery), metallic prosthetic devices or sickle cell anemia must not handle or be in the proximity of the magnets contained inside the pump. Consult a health care provider for specific recommendations before working with this pump.
- ⚠ WARNING: Hot surfaces.** This pump is capable of handling liquids with temperatures as high as 250° F. This may cause the outer areas of the pump to become hot as well and could cause burns.
- ⚠ WARNING: Check for leaks on a regular basis.** If any leaks are found, the pump must be repaired immediately.
- ⚠ WARNING: Rotating Parts.** This pump has components that rotate while in operation. Follow local safety standards for locking out the motor from the power supply during maintenance or service.
- ⚠ WARNING: Chemical Hazard.** This pump is used for transferring many types of potentially dangerous chemicals. *Always* wear protective clothing, eye protection and follow standard safety procedures when handling corrosive or personally harmful materials. Proper procedures should be followed for draining and decontaminating the pump before disassembly and inspection of the pump. There may be small quantities of chemicals present during inspection.
- ⚠ WARNING: Never run pump at less than minimum flow or with the discharge valve closed.** This could lead to pump failure.
- ⚠ WARNING: Never operate the pump without safety features installed.**
- ⚠ WARNING: The pump and associated components are heavy.** Failure to properly support the pump during lifting and movement could result in serious injury or damage to the pump and components.
- ⚠ CAUTION: Do not run the pump dry.** This pump should never be started without liquid in the casing. This could damage the pump. The fluid being transferred by the pump lubricates the pump components. Even short periods of running the pump dry could damage the pump. It is recommended that run dry protection be used. Optional electronic power monitors are available to help protect against run dry.
- ⚠ CAUTION: The correct o-ring material must be chosen to ensure compatibility with the fluid being pumped.** If the incorrect material is chosen, it can lead to swollen or degrading o-rings that allow leaking. O-ring material selection is the responsibility of the end user.
- ⚠ CAUTION: Never start or operate with a closed suction valve. Never operate with a closed discharge valve.**
- ⚠ CAUTION: Always provide adequate NPSHa (net positive suction head available).**

**ADDITIONAL SAFETY PRECAUTIONS FOR ATEX COMPLIANT PUMPS****⚠ Protection Control**

A power monitor, flow switch, pressure switch or similar device must be used to protect against dry running, closed discharge valve or decoupling. Any of these conditions could lead to a rise in surface temperature of the pump.

**⚠ Construction Materials**

Pump must be manufactured with a bronze bump ring and have the designation "B" in the pump part number. The bronze bump ring is pressed into the motor adapter and prevents sparking should the motor bearings fail and the outer drive magnet runs out of round.

**⚠ Grounding**

Static sparking can cause an explosion. When operating in a hazardous area or pumping a hazardous fluid the entire pump system must be grounded to prevent static discharge. Before operating the pump, ensure the electrical continuity throughout the pumping system and earth ground is ( 1 ) Ohm or less. If greater than ( 1 ) Ohm, re-check all grounding connections.

**⚠ Static Hazard**

Static sparking can cause explosion. Excessive fluid flow rates and improper tank filling methods can produce static electricity causing an explosion. Ensure safe fluid velocities and tank filling procedures in compliance with CLC/TR 60079-32-1. Use caution when servicing the pump as non-conductive internal components may carry a charge. Before exposing pump internals to an explosive atmosphere, use industry best practices for dissipating any potential charge. Typical methods for preparing the pump for maintenance include flushing the pump with conductive fluid or purging the explosive atmosphere with inert gas.

**⚠ Elastomer Selection**

Proper o-ring material must be chosen for the fluid being pumped. Improper material selection could lead to swelling and be a possible source of leaks. This is the responsibility of the end user.

**⚠ Leaks**

The pump must be checked for leaks on a regular basis. If leaks are noticed, the pump must be repaired or replaced immediately.

**⚠ Temperature Classification**

The surface temperature of the UCR Series pumps depends upon the temperature of the fluid that is being pumped. The following chart lists different fluid temperatures and the corresponding pump surface temperature.

Fluid Temperature	Maximum Surface Temperature	Temperature Class	Maximum Allowable Surface Temperature
Tfluid < 74°F (23°C)	136°F (58°C)	T6	185°F (85°C)
74°F (23°C) < Tfluid < 250°F (121°C)	214°F (101°C)	T4	275°F (135°C)

**⚠ Cleaning**

The pump must be cleaned on a regular basis to avoid dust build up greater than 5 mm.

**⚠ Motor Rotation Test**

Pump must be full of liquid with no trapped air in the suction and discharge lines before the rotation of the motor is checked. Do not operate pump until it is full of liquid.

**⚠ Start up**

The pump must be filled from a flooded suction tank (gravity) or primed with liquid from an outside source. Open the inlet (suction) and discharge valves completely and allow the pump to fill with liquid. Close the discharge valve. Turn the pump on and slowly open the discharge valve. Adjust the flow rate and pressure by regulating the discharge valve. Do not attempt to adjust the flow with the suction valve.

**⚠ Maintenance**

The recommended maintenance schedule depends upon the nature of the fluid being pumped and the specific application. If the pump is used on a clean fluid, it is recommended that the pump be removed from service and examined after six months of operation or after 2,000 hours of operation. If the pump is used on fluids with solids, high temperatures or other items that could cause accelerated wear, then this initial examination should be sooner.

After the initial examination of the internal components and wear items are measured, a specific maintenance schedule can be determined. For best results, it is recommended that the pump be removed from service annually for examination.

## ULTRAChem Features

The Finish Thompson ULTRAChem is a sealless, magnetically driven, ANSI dimensional, ETFE lined chemical pump. It has been specifically designed for corrosive chemical applications in a wide range of industrial services.

The ULTRAChem features a closed impeller, suction straightening vanes, balanced axial thrust with a rear sealing ring, balance holes and balanced radial thrust due to the modified concentric or partial splitter volute shapes.

The ULTRAChem uses standard silicon carbide shaft, thrust bearings and bushings (optional carbon bushings allow limited run dry capabilities). All metallic components are steel or cast ductile iron.

High strength, rare earth neodymium iron boron magnets are used for maximum power and reliability. Finish Thompson's patented magnetic technology ensures an extraordinarily strong, secure coupling between the motor and pump.

The barrier consists of a precision molded carbon filled ETFE liner with an external aramid fabric/epoxy shell for superior mechanical strength and elimination of eddy currents in the magnetic coupling. The sealless design virtually eliminates maintenance and environmental emissions.

The Easy Set drive feature makes installation of the outer drive quick and easy. It eliminates the need for measuring and ensures that the inner and outer magnets are perfectly aligned to transmit maximum power.

The ULTRAChem has drive hubs and motor adapters for a complete range of NEMA and IEC motor frames. The suction and discharge flanges can be drilled to fit ANSI 150#, 300# and ISO PN40 bolting dimensions.

These features combine to provide our customers with a pump that offers a broad operating range with outstanding reliability due to minimum hydraulic loads and premium materials of construction.

FTI's ATEX compliant pumps meet Directive 2014/34/EU for use in potentially explosive atmospheres.

## ULTRAChem Capabilities

Maximum Working Pressure:	300 psi (20.7 bar)
Maximum Temperature:	250°F (121° C), (E-magnet up to 220° F (104° C) Application Dependent )
Minimum Temperature:	-20°F (-29° C)
Maximum Flow:	1450 US GPM (329 m3/hr)
Maximum Head:	492 ft (150 m)
Maximum Viscosity:	200 cP
Maximum Noise Level:	80 dBA (pump only)
Solids:	Maximum particle size is 50 microns for slurries and 1/64" (.4 mm) for infrequent particles. Maximum hardness is 80 HS. Maximum concentration is 5% by weight. If solids are being pumped, it is recommended the pump have the silicon carbide bushings and thrust washer.

## Maximum Allowable Horsepower

Do not exceed the maximum horsepower rating for the pump coupling. Refer to the chart below. Use the first six or seven characters from the model number listed on the label found on the motor adapter.

Magnet Set	60 Hz (3500 RPM)		50 Hz (2900 RPM)		30 Hz (1750 RPM)		25Hz (1450 RPM)	
	HP	kW	HP	kW	HP	kW	HP	kW
B	20	15	15	11	10	7.5	7.5	5.5
C	40	30	30	22	20	15	15	11
D	60	45	50	37	30	22	25	18.5
E	75	55	60	45	40	30	30	22
F	100	75	75	55	50	37	40	30



## Minimum Allowable Flow Rate

Do not allow the flow rate to drop below the minimum flow rate listed in the chart below. Use the first five or six characters from the model number listed on label found on the motor adapter.

Model	Minimum GPM @ 3500 RPM	Minimum M <sup>3</sup> /Hr @ 2900 RPM	Minimum GPM @ 1750 RPM	Minimum M <sup>3</sup> /Hr @ 1450 RPM
UCR2110/2110L	15	3.4	10	2.3
UCR3110	15	3.4	10	2.3
UCR3158	20	3.8	10	1.9
UCR328	20	3.8	10	1.9
UCR3210	15	3.4	10	2.3
UCR436	20	3.8	10	1.9
UCR438	20	3.8	10	1.9
UCR4310H	N/A	N/A	75	11.4
UCR6410	N/A	N/A	75	11.4

## ULTRAChem Model Codes and Abbreviations

All models standard with ETFE-lined ductile iron housing.

Base	Magnet Set	Flange	Coupling	Bushing	Shaft	O-ring	Thrust Ring	Impeller	Motor Adapter	
UCR2110	B - to 20 HP	O - ANSI 150#	C - Close coupled	S - SiC	S - SiC	V - FKM	S - SiC	600 - 6"	<b>NEMA</b>	<b>IEC</b>
UCR2110L	C - to 40 HP	T - ANSI 300 #	F - Frame mounted	C - Carbon	D - Dri-Coat	E - EPDM		to	14 - 145TC	90 - 90/B14
UCR3110	D - to 60 HP	I - ISO PN40		D - Dri-Coat		K - Kalrez		150 - 10.5"	18 - 184TC	10 - 100-112/B5
UCR3158	E - to 75 HP					S - Simriz			21 - 215TC	13 - 132/B5
UCR328	F - to 100 HP					A - Aflas			25 - 254/256TC	16 - 160/B5
UCR3210						T - FEP/FKM			28 - 282/284TC	19 - 180/B5
UCR438						T = FEP Encapsulated			29 - 282/284TSC	20 - 200/B5
UCR436									32 - 324/326TC	22 - 225/B5
									33 - 324/326TSC	23 - 250/B5
									36 - 364/365TC	24 - 280/B5
									37 - 364/365TSC	
									46 - 404/405TSC	
UCR4310H	B - to 10 HP									
	C - to 20 HP									
UCR6410	D - to 30 HP									
	E - to 40 HP									
	F - to 50 HP									
									<b>Frame Mounted</b>	
									FO - Frame mount, flood oil	
									FB - Frame mount, regreasable bearings	



## Unpacking and Inspection

Unpack the pump and examine for any signs of shipping damage. If damage is detected, save the packaging and notify the carrier immediately.

To install the pump, follow the installation instructions provided.

**⚠ WARNING:** The pump and associated components are heavy. Failure to properly support the pump during lifting and movement could result in serious injury or damage to the pump and components.

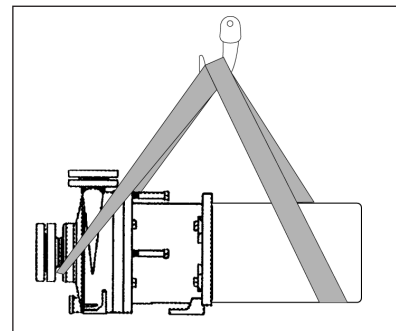

## Model Number and Serial Number

Record the model number and serial number for future reference. Use the location provided on the front cover of this manual. This is important information when ordering replacement parts or when technical assistance is required. The model and serial number are found on a label located on the motor adapter.

## Installation

To install a motor to a pump end, see section Assembly of Pumps without Motors, and then proceed to section Foundation.

**Note:** A hydrostatic test was performed prior to shipment. It is normal for a small amount of water to be retained inside the pump.

### Vertical Operation

UCR Series pumps can be installed in a vertical position (either pump facing up or pump facing down) but the motor **MUST** be an IEC 100 frame motor or larger. IEC motors have a bolt in the motor shaft that prevents the outer drive from moving. IEC 90 frame and smaller motors contain a wavy washer on both ends of the motor shaft that can allow the outer drive to potentially rub. The pump must be securely fastened to a solid material capable of absorbing any vibration that the pump will produce.

### Pumps with Motors:

Proceed to Foundation Section.

### Pumps without Motors:

- Prepare to install the motor on the pump. Carefully place the motor and pump end on a suitable, level work surface (a nonmagnetic surface is preferred). Make sure the work surface is free of metal chips or particles.
  - ⚠ Magnetic Force Hazard.** This pump should only be disassembled and assembled using the recommended procedures. The magnetic attraction is powerful enough to rapidly pull the motor end and the wet end together. **ALWAYS** use the jackscrews (item 14) to assemble/disassemble the pump. Do not place fingers between the mating surfaces of the motor and wet ends to avoid injuries. Keep the drive magnet and impeller assembly away from metal chips or particles.
  - ⚠ CAUTION:** Keep the drive hub away from the open end of the motor adapter and barrier. Strong magnetic attraction could allow the drive hub to enter the motor adapter resulting in injury or damage.
- Using a 24 mm socket, unbolt the wet end (items 1-7) from the motor adapter by removing the (4) M16 hex head cap screws (item 15). Make sure the (2) jackscrews (item 14) are fully extended. Using a 24 mm socket turn the jackscrews clockwise until they are fully extended. See figure 1.
- Coat the motor shaft with anti-seize paste. Slide the drive shaft adapter (item 8B) onto the motor shaft with the key in the keyway. Slide the adapter until the retaining ring touches the end of the motor shaft. See figure 2.
  - A. For installation onto NEMA motor frames:
    - i. Using a 3/16" bit and torque wrench, tighten both setscrews to 228 in-lbs. (25.8N-m)
  - B. For installation onto IEC motor frames:
    - i. Install flat washer, lock washer, and bolt (items 18, 19 & 20) into the end of the motor shaft and then tighten to the following torque settings:
      - IEC 90 B5- M8-1.25: 120 in-lbs (13.7 N-m)
      - IEC 100/112 B5- M10-1.5: 250 in-lbs (28.2 N-m)
      - IEC 132 B5- M12-1.75: 35 ft-lbs (47.5 N-m)
      - IEC 160/180 B5- M16-2.0: 90 ft-lbs (122 N-m)
      - IEC 200/225 B5- M20-2.5: 90 ft-lbs (122 N-m)
      - IEC 250/280 B5- M20-2.5 x 40: 90 ft-lbs (122 N-m)
      - IEC 250/280 B5- M20-2.5 x 40: 90ft-lbs (122 N-m)

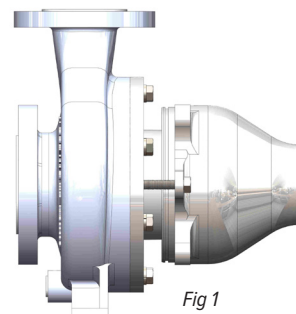

Fig 1

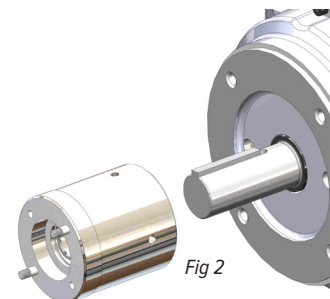

Fig 2

**Note:** The shaft adapter is held to a tight tolerance (+0.0005”/-0.0000) to the motor shaft, so it may be necessary to tap the shaft adapter with a soft faced mallet or heat it with an oven/induction heater to around 180° F (82° C) to fully seat it. Be careful to not damage the shaft adapter during this process.

- Install vapor protection o-ring (item 25) in the groove on the back of the motor adapter (item 9) use petroleum jelly or similar substance to help hold the o-ring in place. Slide the motor adapter over the shaft adapter and attach it to the motor face. Use the (4) supplied hex head cap screws & lock washers (items 16 & 16A) and torque evenly to the following values. See figure 3.

NEMA 145TC: 3/8-16, 15 ft-lbs (20.3 N-m)

NEMA 184/215/254/284/286: ½-13, 75 ft-lbs (101.7 N-m)

NEMA 324/364: 5/8-11, 90 ft-lbs (122 N-m)

IEC 90 B5: M10-1.5, 20 ft-lbs (27.1 N-m)

IEC 100/112/132 B5: M12-1.75, 35 ft-lbs (47.5 N-m)

IEC 160/180/200/225 B5: M16-2.0, 90 ft-lbs (122 N-m)

IEC 250/280 B5: 5/8” - 11 x 2”, 90 ft-lbs (122 N-m)

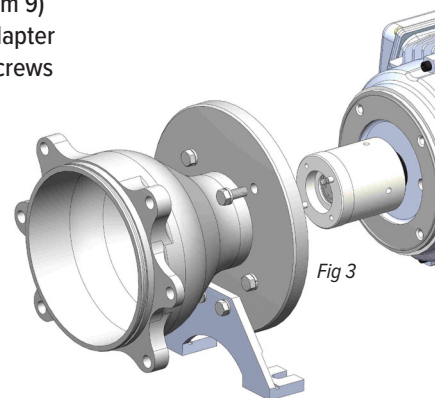

- Lightly coat the bore of the magnet hub (item 8A) with anti-seize paste. See figure 4.

- Using the two threaded studs, carefully slide the magnet hub onto the shaft adapter. See figure 5. It maybe necessary to lightly tap, or use the supplied hex head bolts to pull the hub into position. Use the supplied (2) hex head bolts, (4) lock washers and (2) hex nuts (items 21, 22 & 23) to secure the magnets into position. Torque the bolts and nuts (M8) to 120 in-lbs (13.7 N-m). See figure 5.

**Note:** Use supplied cardboard to help protect the outer drive magnets from damage from tools. Be sure to remove the tube after drive is securely attached. Save tube should any future repairs be necessary. If your pump did not ship with one of these tubes, please consult the spare parts list for ordering information.

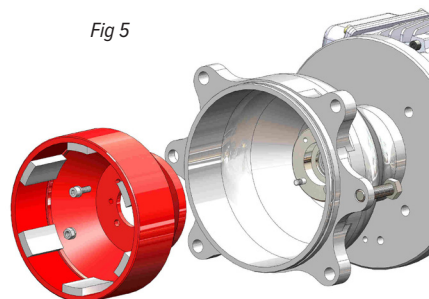
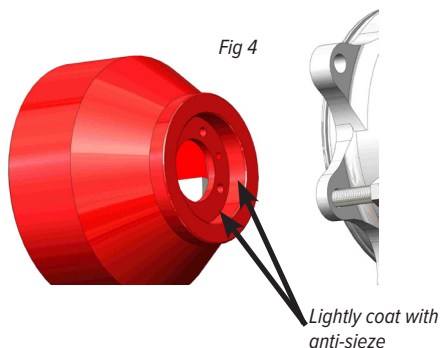

- Lubricate the vapor protection o-ring (item 24) on the front of the motor adapter with petroleum jelly. See figure 6.
- Carefully slide the wet end towards the motor adapter until it touches the jackscrews (item 14) there will be some magnetic attraction. Make sure the (2) jackscrews are fully extended. See figure 7.
- Slowly and evenly turn the jackscrews counterclockwise to allow the wet end to slowly slide into the motor adapter. When the jackscrews are fully retracted, lift the wet end slightly and slide it onto the motor adapter's locating flange. If necessary the M16 motor adapter bolts may be used to draw the pump end onto the motor adapter. Be careful not to cut or damage the vapor protection o-ring (item 24).
- Bolt the wet end to the motor adapter by reinstalling the (4) M16 hex head cap screws & lock washers (items 15 & 15A) and torque evenly to 90 ft-lbs (122 N-m). See figure 8.

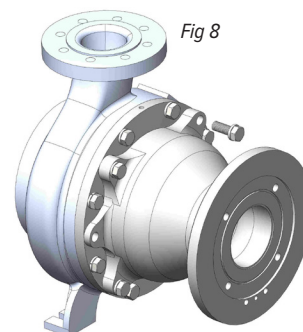
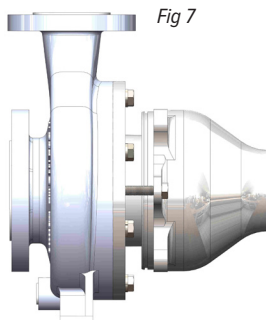
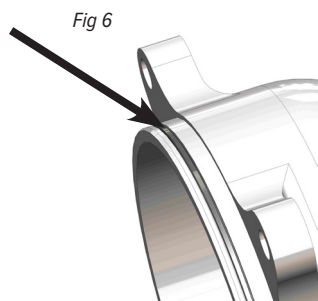

## Foundation

1. The foundation that the pump will be sitting on should be strong enough to support the pump as well as absorb any vibration that the pump will produce. A concrete platform should be acceptable. Bolts embedded in the concrete can be placed by using a template or drawing. The use of a pipe sleeve larger than the bolt will compensate for base movement for final bolt location.
2. You must allow a gap no greater than 1-1/2" between base and foundation for grouting.

## Base plate

1. The base plate of the ULTRAChem must be placed on the foundation using two sets of wedges or shims. These shims should be placed on each side of the foundation bolts. Provide enough clearance for proper grouting.
2. Remove any water or other debris from the anchor bolt holes prior to grouting.
3. Carefully lower the base plate onto the foundation bolts.
4. Level the base plate to within 1/8-inch over the length and 1/16-inch over the width. This can be done by adjusting the wedges.
5. Hand tighten the bolts.

## Grout the base plate

1. Ensure that the area that is to be grouted is clean. Follow instructions from the grout manufacturer.
2. Erect a dam around the foundation. Insure that the foundation is thoroughly wetted.
3. Pour grout in the dam and completely fill under and around the base plate to the level of the dam. Make sure that any air bubbles are removed as it is poured. It is recommended that non-shrinking grout be used.
4. Permit the grout to set at least 48 hours.
5. Tighten the foundation bolts.

**⚠ CAUTION:** Do not operate the pump until it is securely fastened!

## Piping

1. The pump should be installed as near to the suction source as possible.
2. It is recommended that pipes are supported as close as possible to the pump and all flanges line up. This will minimize any pipe strain.
3. The suction side of the pump should be as straight and short as possible to minimize pipe friction or a length at least ten times the inlet diameter should follow any elbows.
4. The suction or inlet line should be at least as large as the suction inlet port or one pipe size larger so that it does not affect the NPSHa. Do not reduce the suction line size.
5. The suction line should not have any high spots. This can create air pockets. The suction piping should be level or slope slightly upward to the pump. See figure 9.
6. The NPSH available to the pump must be greater than the NPSH required. Filters, strainers, and any other fittings in the suction line will lower the NPSH available and should be calculated into the application.

Fig 9

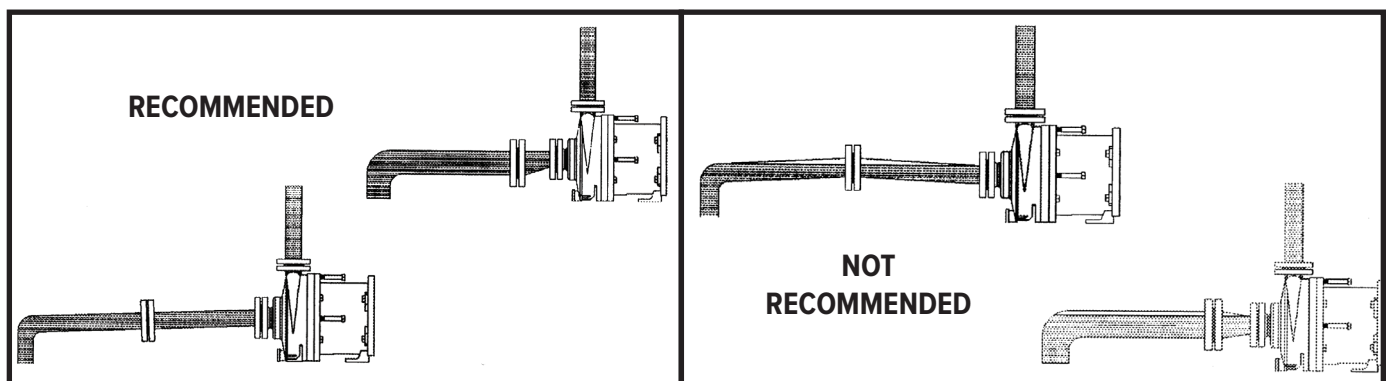

**PUMP SUPPLY**  
INCORPORATED

7. A check valve and a control valve (if used) or isolation valve should be installed on the discharge line. The control valve is used for regulating system flow. An isolation valve is used to make the pump accessible for maintenance. It is recommended that the control or isolation valve be closed prior to stopping or starting the pump. The check valve is installed to protect the pump against water hammer damage. These recommendations are particularly important when the static discharge head is high.
8. It is advisable to install a flush system in the piping to allow the pump to be flushed before the pump is removed from service.
9. When connecting piping to the pump suction and discharge flanges, if lock washers are used, install under the head of the bolt. See figure 10.

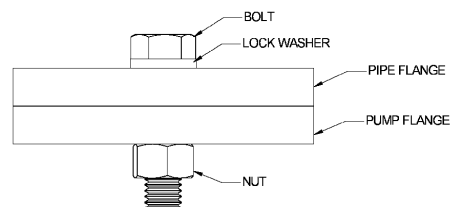

Fig 10

## Motor/Electrical

Only qualified personnel trained in the safe installation and operation of this equipment should install the motor. Install the motor according to National Electric Code, NEMA MG-2, IEC standards requirements, and/or applicable local electric codes. The voltage and frequency variations of the power supply should never exceed the limits established in the applicable standard. Prior to connecting to the power line, check nameplate voltage, rotation connection, and ensure proper grounding. Sufficient ventilation area should be provided to insure proper operation and cooling of the motor. The motor must be installed with a suitable overload protection circuit. For three-phase motors, it is recommended to install a phase failure protection device. Download the motor manual from the specific motor manufacturer's website for additional information concerning motor installation, safety, and maintenance instructions.

Wire the motor for clockwise rotation when facing the fan end of the motor.

**⚠ CAUTION:** Do not operate the pump to check rotation until pump is full of liquid or damage may occur even if the motor is "bumped" to check motor rotation direction.

Check all electrical connections with the wiring diagram on the motor. Make sure the voltage, frequency, phase, and amp draw comply with supply circuit.

If utilized, verify that power monitors or variable frequency drives have been properly installed according to the manufacturer's instructions.

## Operation

### Pre-Operation Inspection

Prior to the first operation of the pump, perform the following inspections:

**⚠ WARNING:** Lock out power to the driver to prevent accidental motor start-up and physical injury.

1. Insert a screwdriver through the fan cover and rotate the fan. It should move without restrictions.
2. Verify that all flange and hold down bolts are tightened.

### Start-up and Operation

1. This pump must be filled from a flooded suction tank (gravity) or primed with liquid from an outside source.
2. The ULTRAChem is not self-priming.
3. Ensure that the pump is full of liquid and the inlet (suction) valve is open.
4. Open the outlet (discharge) valve completely and then close it so that there is no trapped air in the suction and discharge line.
5. After the pump is full of liquid, check that the rotation of the motor/ pump is in the correct direction. This can be achieved by jogging the motor for approximately ½ second. The motor rotation can be observed from the fan end. Correct rotation when viewed from the fan end is clockwise.
6. Note: A pump running backwards will pump but at a greatly reduced flow and pressure.
7. Turn the pump on. Slowly open the discharge valve. Check pump for proper flow and pressure, and that pump runs without excessive noise or vibration.
8. Keep the suction valve in the fully open position. Never use the suction valve to regulate the flow rate. Use the discharge valve only.

**Note:** It is not necessary to jog the motor or adjust the valves on subsequent pump starts provided that the pump and piping remain full of liquid.

- ⚠ CAUTION:** Do not run the pump dry. This could damage the pump. The fluid being transferred by the pump must be liquid. Even short periods of running the pump dry could damage the pump. It is recommended that a dry protection device be used.
- ⚠ CAUTION:** Do not dead head the pump. Running the pump at zero flow will cause any liquid inside the pump to elevate rapidly in temperature. This will continue until the boiling point of the liquid is reached. The liquids will flash to vapor, causing the pump to run dry, and destroy the pump. Run dry protection in the form of a power monitor is recommended.
- ⚠ WARNING:** All ATEX compliant pumps must use a power monitor to protect against running dry, closed discharge valve, and pump decoupling. Any of these conditions could lead to elevated surface temperatures.
- ⚠ CAUTION:** Cavitation for an extended period of time can cause pitting and damage on the pump components. Make certain NPSHa is greater than pump NPSHr.
- ⚠ CAUTION:** Water hammer. Rapid changes in the fluid's velocity can cause large, sudden pressure surges. These pressure surges can damage the pump, plumbing and instrumentation. Common causes are rapidly closing valves. Check valves on the suction can also cause water hammer if the liquid has time to reverse direction before the valve closes.

## Shutdown

Use the following procedures to shut the pump down.

1. Slowly close the discharge valve .
2. Shut off the motor.
3. Close the suction valve.

## Disassembly/Reassembly

### Disassembly

#### Pump End

- ⚠ WARNING:** Rotating Parts. This pump has components that rotate while in operation. Follow local safety standards for locking out the motor from the power supply during maintenance or service.
- ⚠ WARNING:** Chemical Hazard. This pump is used for transferring many types of potentially dangerous chemicals. Always wear protective clothing, eye protection and follow standard safety procedures when handling corrosive or personally harmful materials. Proper procedures should be followed for draining and decontaminating the pump before disassembly and inspection of the pump. There may be small quantities of chemicals present during inspection.
- ⚠ WARNING:** The pump must be thoroughly flushed of any hazardous materials and all internal pressure relieved prior to opening the pump. Shut all valves controlling flow to and from pump. Isolate pump from system and relieve any remaining system pressure before any plugs are removed or piping is disconnected.
- ⚠ WARNING:** Magnetic force hazard. This pump should only be disassembled and assembled using the recommended procedures. The magnetic attraction is powerful enough to rapidly pull the motor end and the wet end together. ALWAYS use the jackscrews (item 14) to assemble/disassemble the pump. Do not place fingers between the mating surfaces of the motor and wet ends to avoid injuries. Keep the drive magnet and impeller assembly away from metal chips or particles.
1. Stop the pump, lock out the motor starter, close all the valves that are connected to the pump, and drain/decontaminate the pump. The ULTRAChem is supplied with a casing drain to help drain and decontaminate the pump. If the drain flange has been removed to drain/decontaminate the pump, reinstall the flange (item 11) and use a new gasket (item 11A). Torque the two flange bolts (M12) (item 11B) to 35 ft-lbs (47.5 N-m).
  2. Allow the pump to reach ambient temperatures prior to performing maintenance.
  3. Remove the mounting bolts that attach the motor to the base, if any.
  4. Using a 24 mm socket, remove the (4) M16 bolts that secure the motoradapter to the clamp ring. See figure 10.

Fig 10

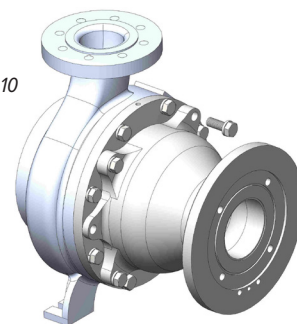

5. Separate the magnetic coupling between the drive end and the pump end by using the two jackscrews (item 14). Using a 24 mm socket turn the jackscrews clockwise. Be sure to turn the jackscrews evenly. Turn the jackscrews until they are fully extended. See figure 11.

**⚠ CAUTION:** After removal of the drive end, the jackscrews should be left fully engaged in the adapter to prevent accidental attraction of the magnetic coupling.

6. Using a 24 mm socket, remove the (8) M16 hex head bolts that connect the clamp ring (item 7) to the casing. See figure 12.
7. Remove the clamp ring from the back of the barrier assembly.
8. Place the casing/barrier assembly on a table with the suction flange of the casing facing down. Carefully remove the barrier assembly from the casing. When pulling the barrier assembly out of the casing, the shaft may stick in the barrier. If this happens, make sure that the shaft does not drop out when the barrier assembly is removed or damage may result. See figure 13.
9. Remove the impeller assembly and the shaft from the casing.

**⚠ CAUTION:** The shaft and impeller can be damaged if dropped.

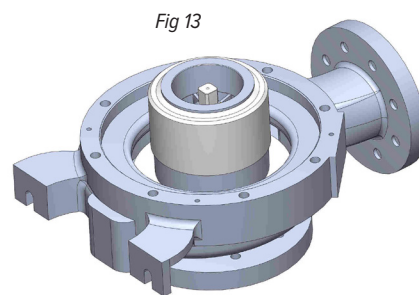
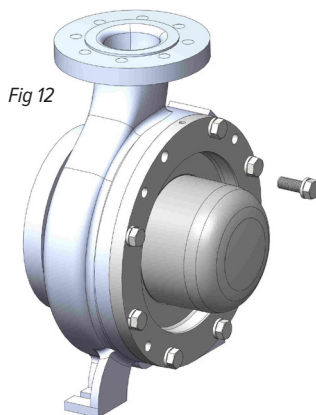
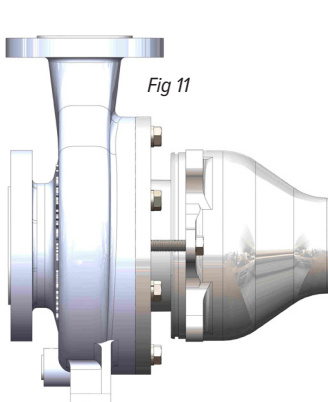

## Power End (motor side)

**⚠ WARNING:** This pump should only be disassembled and assembled using the recommended procedures. The magnetic attraction is powerful enough to rapidly pull the motor end and the wet end together. ALWAYS use the jack-screws (item 14) to assemble/disassemble the pump. Do not place fingers between the mating surfaces of the motor and wet ends to avoid injuries. Keep the drive magnet and impeller assembly away from metal chips or particles.

1. Using a 13 mm socket, remove the (2) M8 hex head cap screws (item 23) and two M8 hex nuts (item 21) that hold the outer magnet ring to the shaft adapter. If necessary, use the two M8 hex bolts as jack screws in the tapped holes of the magnet ring. See figure 14.

**Note:** A cardboard tube is available that helps protect the outer drive magnets from damage. If you do not have one of these tubes, please consult the spare parts list for ordering information.

2. Using the appropriate socket, remove the four hex bolts (item 16) that attach the motor adapter to the motor. Carefully slide the motor adapter off the motor face and over top of the shaft adapter. See figure 15.
3. Inspect the shaft adapter for damage. To remove it from the motor shaft:
  - a. For pumps with a NEMA motor: Loosen the setscrews (item 27) on the shaft adapter and remove it from the motor shaft.
  - b. For pumps with an IEC frame motor - loosen and remove the bolt and washers (items 18, 19 & 20) in the center of the shaft adapter and pull it off the end of the motor shaft.

**Note:** The shaft adapter is held to a tight tolerance (+0.0005"/-0.0000) to the motor shaft, so it may be necessary to use pry bars to help remove it. Be careful to not damage the motor face or motor shaft during this process.

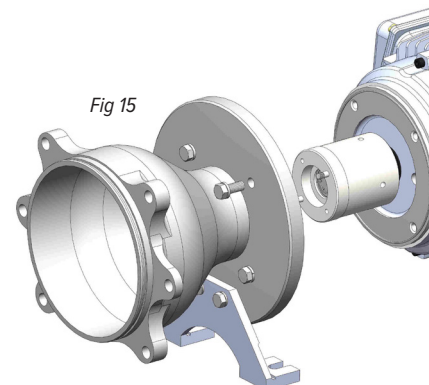
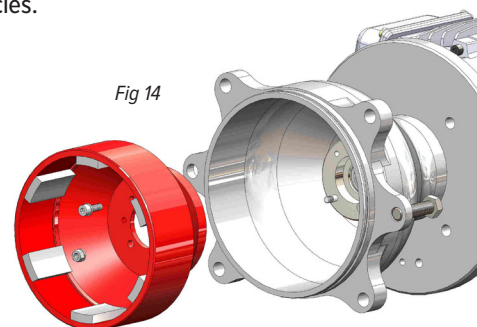

## Examination

The first scheduled inspection should take place after the first three months or approximately after 2000 hours of run time. This is to insure that there is no damage from any solids or particulate, cavitation or run dry. Re-inspect after six to twelve months depending on the results of the initial inspection.

**Note:** All pumps should be checked for leaks on a regular basis. If any leaks are detected, the pump should be repaired immediately.

**Note:** A new o-ring will be required after pump inspection. If the drain flange is removed, replace the gasket.

1. Inspect the bushings (item 4A). The silicon carbide parts will not wear under normal operation. Polishing on a silicon carbide surface is a normal occurrence and usually does not require replacement. Check for signs of melting around the perimeter of the bushings. Make sure that the groove on the bushing ID is not plugged. Check for chips or cracks. Check bushings for wear. If the bushings appear worn, follow the steps listed in the section "Replacing Wear Components, Impeller Bushings". See figure 16A.
2. Check for cracks or excessive wear on the shaft (item 5), impeller thrust ring (item 3A) and rear sealing ring (item 4C). Replace if cracked or excessively worn. See figures 16B, 16C, & 16D.
3. Check for signs of deformation or melting in the shaft support (item 2) and the barrier assembly (item 6) where the pump shaft is positioned. Dry running of the pump during initial start-up or operation will cause heat-related damage to these components.
4. Inspect the casing liner (item 1). It is important that there are no abrasions or cuts deeper than .04 inch in the lining. These cracks may occur if the lining is corroded or abraded. Liner damage can usually be detected visually. Some hairline cracks require an electrostatic discharge tester to detect.
5. Locate the impeller assembly (item 3). Make certain that there are no obstructions. If there is an obstruction or product build up in any of the flow paths, an imbalance will cause excessive vibration and wear on the pump shaft and impeller bushings.
6. Check the impeller drive assembly (item 4) for cracks or grooves larger than .02 inch. If a fluid comes in direct contact with the magnets, the magnets may swell, cause rubbing, and damage the barrier assembly (item 6).
7. Inspect the barrier assembly (item 6) for signs of abrasion. Replace the barrier assembly if there are grooves or scratches that are deeper than .04 inch.

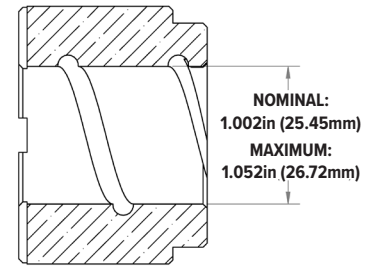

Fig 16A

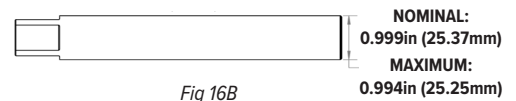

Fig 16B

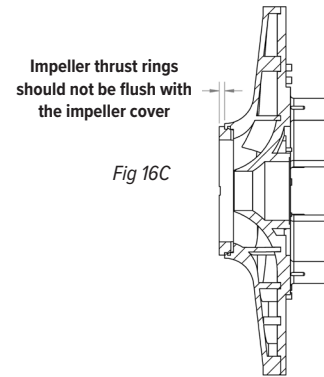

Fig 16C

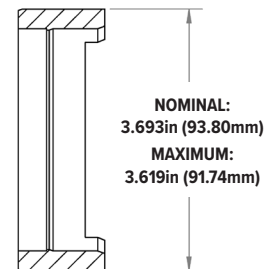

Fig 16D

**Illinois Location:**

(847) 841-7867  
1675 Todd Farm Dr.  
Elgin, IL 60123

**Minnesota Location:**

(651) 758-7867  
330 Mill Bay South Suite 1511  
Afton, MN 55001

PumpSupplyInc.com

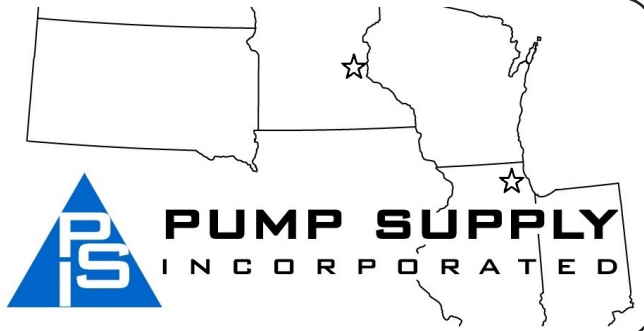

## Replacing Wear Components

Use the following procedures to replace any wear components that are excessively worn, cracked or broken.

### Shaft Support/Front Thrust Washer Removal

1. Remove the casing (item 1) from the base plate and piping.
2. Place the casing in an arbor press with ETFE lining side down. Note: care should be taken to not damage the lining.
3. Place arbor on the nose of the front shaft support (item 2) and carefully press the front shaft support out of casing. See figure 17. Note: Care should be taken to not damage the silicon carbide thrust ring (item 2A). Use something soft to catch the shaft support as it drops from the casing.



Fig 17

### Installation of Replacement Support/Front Thrust Washer

1. Place the casing in an arbor press with the suction flange down.
2. If the silicon carbide thrust ring (item 2A) is damaged and needs to be replaced the PTFE o-ring (item 2B) should also be replaced. Remove the thrust ring by hand. Install the new o-ring in the groove and press the new thrust ring into the shaft support being sure to line up the 4 slots in the ring with the four tabs on the shaft support.
3. Position the front shaft support in the bore of the casing suction and align the anti-rotation pins on the front shaft support with the blind slots in the casing.
4. Press evenly on the face of the plastic shaft support with a soft-faced arbor until the front shaft support is fully seated in the bore.

### Impeller Thrust Ring

The impeller thrust ring is located in the front of the impeller shroud.

#### Removal

1. The silicon carbide impeller thrust ring (item 3A) must be broken to remove it from the impeller. Be careful not to damage the bore or face of the front impeller shroud. Silicon carbide is brittle and can be broken easily by hitting it with a hammer. Care should be taken during this process to prevent personal injury from flying debris or sharp edges. Wear proper safety clothing.

Note: A new impeller thrust ring with PTFE encapsulated o-ring will be required after removal.

#### Replacement

1. Place the impeller and impeller drive assembly (items 2B, 3, 3A, 4, 4A & 4C) on a table with the eye of the impeller facing up.
2. Using petroleum jelly or similar substance, place the o-ring (item 2B) into the groove on the rear of the impeller thrust ring (item 3A). See figure 18.
3. Position the replacement impeller thrust ring in the bore of the front shroud with the snap fit ridge towards the bottom of the bore. See figure 19. Align the two anti-rotation slots on the impeller thrust ring with the two raised bosses of the impeller shroud.
4. Place the impeller and impeller drive assembly in an arbor press. Using a soft faced arbor, gently press the impeller thrust ring into place. Make sure thrust ring is completely seated. See figure 20.

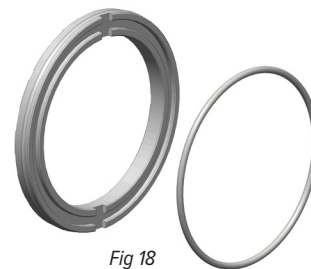

Fig 18

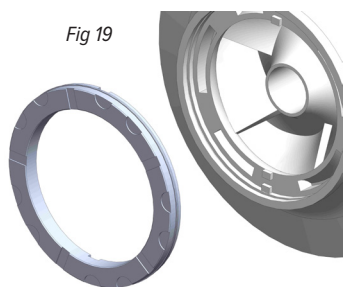

Fig 19

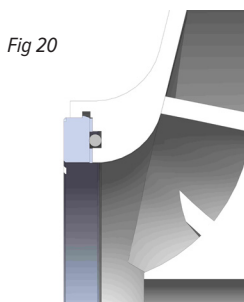

Fig 20



## Rear Sealing Ring (all models)

The rear sealing ring (item 4C) is located in the rear bore of the barrier assembly (item 6).

### Removal

1. Place barrier (item 6) on a table with open side facing up.
2. Remove rear sealing ring by cutting it with a #18 straight edge X-Acto knife or similar blade & gently cut through the ring. Once cut, pry open and remove the ring from the barrier inner shaft boss. See figure 22.
3. Using a rotary cutting tool, carefully cut the sealing ring retainer and sealing ring retainer lock so they can be removed. Be careful not to damage the barrier liner.
4. Remove old parts and clean any debris from barrier.

### Replacement

1. Place barrier (item 6) in an arbor press with the open side facing up.
2. Place the rear sealing ring on the inner shaft boss of the barrier assembly, align the two tabs so they will fit in between the ribs located in the bottom of the barrier. See figure 23.
3. Place sealing ring retainer onto barrier liner by aligning the three lobes. Press down until fully seated. Rotate sealing ring retainer until the three lobes line up with the lobes in the barrier. If the retainer does not easily rotate press down again to ensure it is fully seated. It should rotate freely.
4. Place sealing ring retainer lock on by aligning the three tabs with the lobes in the barrier.
5. Gently press the ring into place evenly using an arbor press and a 2.25" (57.2 mm) diameter tool.

Note: this is the minimum inner diameter for the tool to fit over the rear shaft boss. See figures 24, 25, 26.

6. Sealing ring retainer lock is fully seated when it "snaps" into the machined groove on the sealing ring retainer. The top of the locking ring and the top of the retainer should be even. See figure 27.

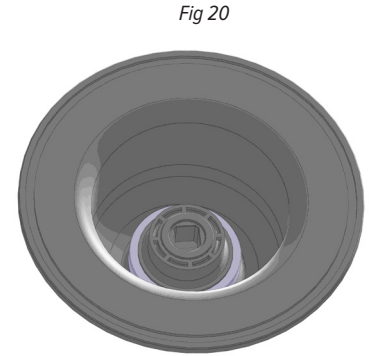
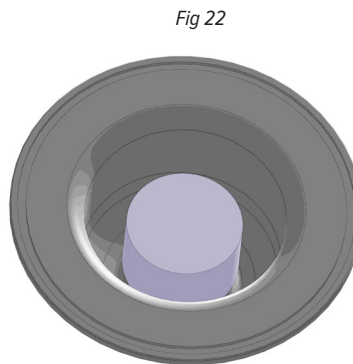
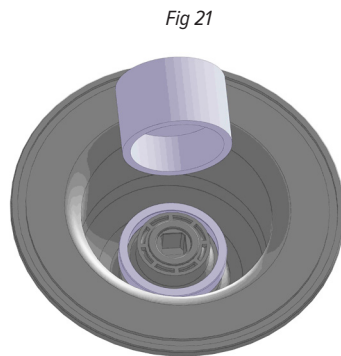

#### Illinois Location:

(847) 841-7867  
1675 Todd Farm Dr.  
Elgin, IL 60123

#### Minnesota Location:

(651) 758-7867  
330 Mill Bay South Suite 1511  
Afton, MN 55001

PumpSupplyInc.com



**UCR Single Piece Impeller & Snap-fit Drive Disassembly and Assembly Instructions.**

**Removal**

1. To remove the impeller from the drive hub to replace bushings or trim an impeller you must use removal tool (P/N 111428) & a 9/16" socket & ratchet tool. **Important Note: Only use hand tools.** Air or power tools will cause damage to the impeller bushings and/or other components. See figure 24.
2. From the drive end locate the snap-fit prongs on either side of the bushing. See figure 25.



Fig 24: Impeller Removal Tool includes: prong release tool, 5" long bolt, bushing, & drive pin.

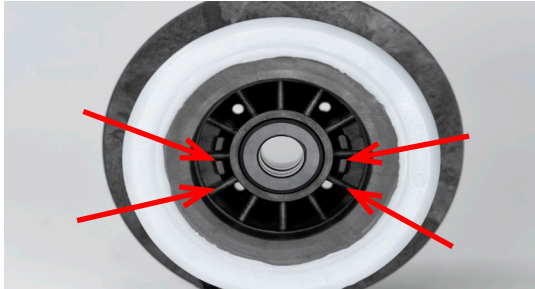

Fig 25

3. Insert the prong release tool into the impeller drive making sure the four prongs from the tool line up with the four snap-fit prongs from the impeller. Failure to properly align the prongs could damage the impeller. Push it into the impeller drive until it snaps in place. See Figures 26 & 27.
4. Turn the impeller assembly over and insert the bolt with plastic bushing through the eye of the impeller and thread it into the prong release tool until snug. Use a 9/16" socket & ratchet wrench. Caution: Do not overtighten. See figures 28 through 31 below.

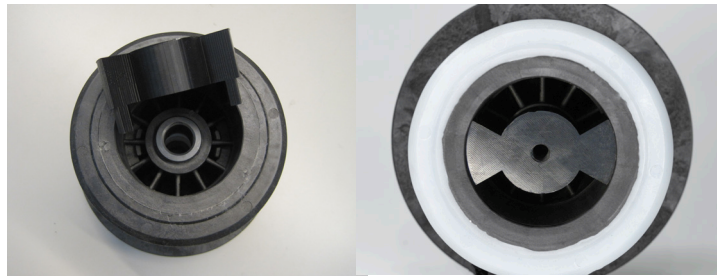

Fig 26

Fig 27



Fig 28

Fig 29

Fig 30

Fig 31

5. Turn the impeller assembly over and rest it on the impeller side. Suggest using a piece of wood or plastic to support the impeller and prevent it from moving. **Caution** - magnets are strong & may attract metal tools or other metallic items. Insert the drive pin into one of the 8 open slots on either side of the prong release tool. Tap the drive pin to start the separation of the impeller & impeller drive. Move the drive pin from one side to the other evenly as the impeller is disengaged. See figures 32 & 33.



Fig 32

Fig 33



- This will disengage the snap-fit prongs and allow the impeller and drive to separate. This will require about 7/8" of separation between the impeller back shroud and the drive before they can be completely separated. See figures 34 through 36.

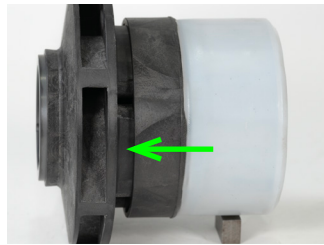

Fig 34

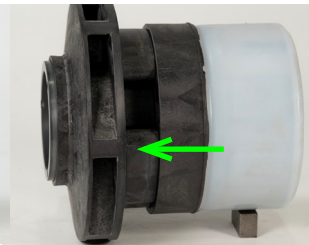

Fig 35



Fig 36

- Unthread the bolt used for the impeller eye and remove the tool from the drive hub. See figures 37 through 39 below. Take care to not drop the impeller bushing if tipping the drive over.



Fig 37



Fig 38

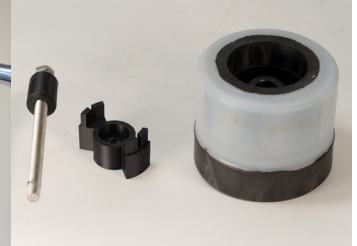

Fig 39

**Replacement**

- Make sure the bushing and spacer are properly inserted in the impeller drive. Bushing nose piece will stick out about 1/4" from the impeller drive. See figure 40.
- Place the drive hub assembly in an arbor press with the kidney shaped slots facing up. See figure 41 below. Be careful that the impeller bushing does not fall out during the assembly process.
- Align the snap-fit prongs from the impeller vanes with the larger slots on the drive. See figure 20A below.



Fig 40: Impeller Removal Tool includes: prong release tool, 5" long bolt, bushing, & drive pin.

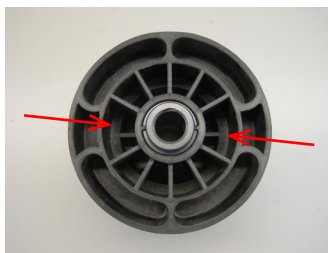

Fig 41

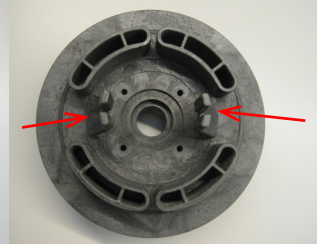

Fig 42

- Complete installation by pressing the impeller assembly into the impeller drive with an appropriate size arbor. Be sure the arbor does not touch the impeller thrust ring. Use an arbor with a larger diameter than the eye of the impeller. See figure 43 & 44 below. Press until the back side of the impeller rear shroud is flush with the front face of the drive hub assembly. See figures 45 through 47 below.



Fig 43



Fig 44

- Impeller can now be reinstalled back into the pump. Feel free to contact Finish Thompson, Inc if you have questions @ 1-800-888-3743.



Fig 45

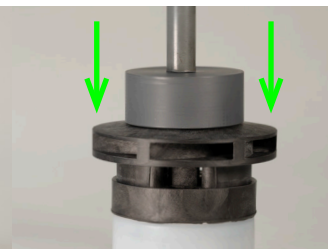

Fig 46

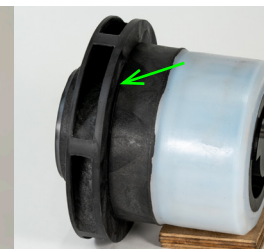

Fig 47



## Impeller Bushings



### Removal

1. Remove the impeller (item 3, 3A) according to the steps listed in the section Impeller Assembly, Removal. Remove the top bushing and spacer by hand.
2. Place the impeller drive assembly (items 4,4A, 4B, 4C) on an arbor press with the front of the impeller drive facing down. Ensure there is at least 2" under the bushing to allow its complete removal, Put something soft down underneath the Impeller drive to catch the bushing.
3. Insert bushing removal tool through the rear bushing bore until it clears the 1st bushing. When the lip of the tool is between bushings, expand tool using two wrenches. Once arbor is fully expanded, press down on bushing. There will be some force required as we will need to shear the PTFE bushing retaining ring. See figure 30.
4. Once one bushing is removed, remove bushing removal tool and flip drive over.
5. Expand the bushing removal tool, or use a plastic arbor approximately 1-1/2" in diameter to remove 2nd bushing. Some force will be required to shear the PTFE bushing retainer ring.
6. Check the impeller bore for signs of plastic melting or fretting wear.

### Replacement

1. Place drive flat onto either the top or bottom surface.
2. Install new bushing retaining rings by opening them slightly and installing in the groove on the bushing. The wide end of the ring should face away from the square of the bushing.
3. Line up the square on the bushing with the square of the impeller drive
4. Press bushing until it is fully seated.
5. Flip drive over and repeat for the other bushing.
6. Check alignment by placing drive over shaft to ensure no binding occurs. If binding occurs, remove bushings, replace bushing retainer rings, and re-install bushing.

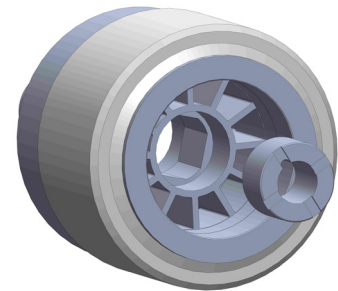

figure 26

## Power End Reassembly

See section Assembly of Pumps without Motors, steps 1-9 on pages 6-8.

### Pump End Reassembly

1. Take the pump casing (item 1) and lay it suction side down on a clean flat surface. See figure 27. Note: Care should be taken to not damage the lining.
2. Carefully place the impeller (item 3) and impeller drive assembly (item 4) into the housing onto the thrust ring. See figure 28.  
CAUTION: Do not use steel/iron tools near the magnets. These tools are attracted to the strong magnetic force and could damage them upon impact.
3. Install a new o-ring (item 12) in the housing. See figure 29. If removed, reinstall the shaft (item 5) align the four flats on the one end with the flats on the barrier assembly and push in by hand.
4. Slide the barrier and shaft assembly over the impeller assembly and through the bushings. Align the shaft with the front shaft support. Press down on the barrier assembly until it is fully seated. See figure 30.

figure 27



figure 28

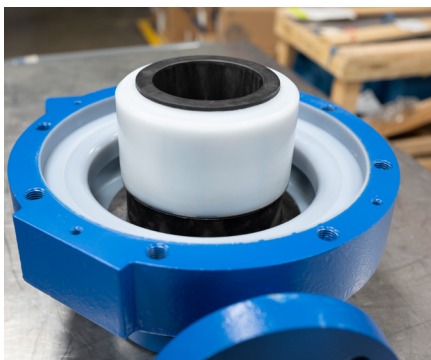

figure 29

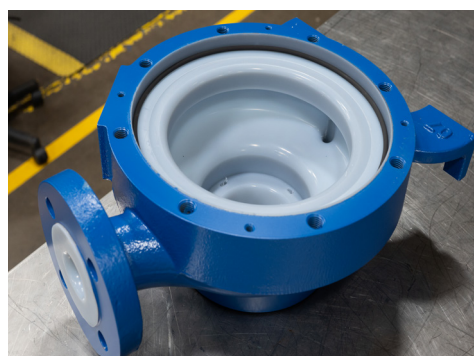
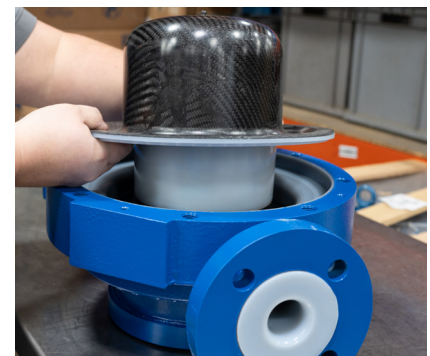

figure 30



5. Make sure the vapor protection o-ring (item 24) is in the clamp ring groove (item 7). See figure 31a. Place the rounded edge of the clamp ring over the barrier assembly and position on the rear face of the casing. **Note:** It is important to properly line up the 8-through holes in the clamp ring to the 8 threaded holes in the casing. See figure 31b. The 4 threaded holes in the clamp ring should align per figure 31c.
6. Attach the clamp ring with (8) M16 hex head cap screws and lock washers (items 13 & 13A). Tighten evenly around circumference. Torque the screws to 90 ft-lbs (122 N-m) unlubricated.
7. Lubricate the vapor protection o-ring on the front side of the motor adapter using a compatible lubricant. See figure 32.
8. Make sure the (2) jackscrews (item 14) are fully extended. If not turn the (2) jackscrews clockwise until the heads touch the motor adapter.
9. Carefully slide the wet end towards (items 1-7) the motor adapter (item 9) until it touches the jackscrews (there will be some magnetic attraction). See figure 33.
10. Slowly and evenly turn the jackscrews counterclockwise to allow the wet end to slowly slide into the motor adapter. Be careful not to cut the o-ring as the assembly is put together. When the jackscrews are fully retracted, if necessary use the (4) M16 hex head bolts (item 15) to draw the pump end onto the motor adapter.
11. Bolt the wet end to the motor adapter by installing the (4) M16 hex head cap screws & lock washers (items 15 & 15A) and torque evenly to 90 ft-lbs (122 N-m). See figure 34.

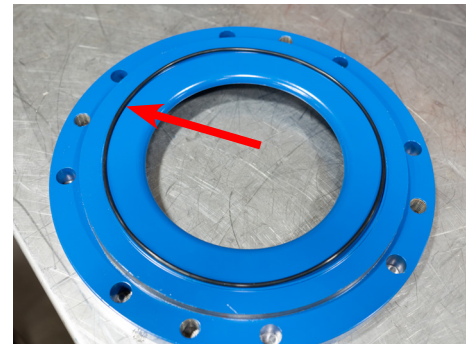

figure 31a



figure 31b

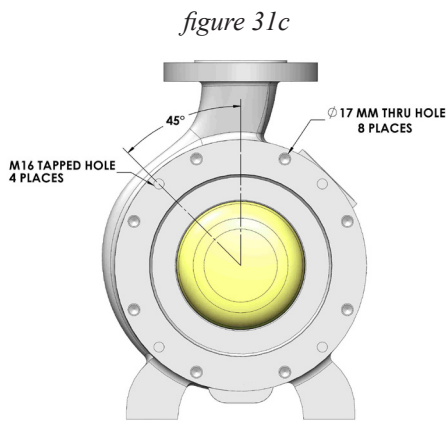

figure 31c

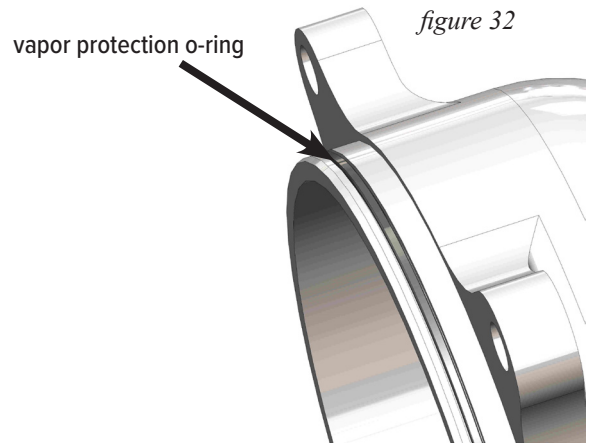

figure 32

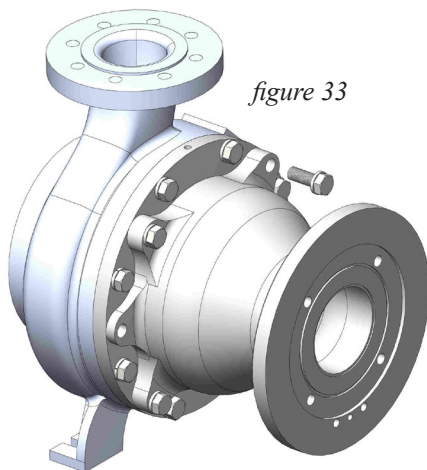

figure 33

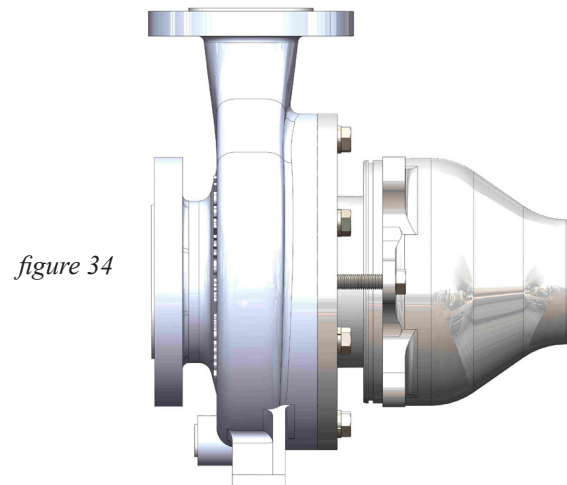

figure 34

## TROUBLESHOOTING

### NO OR INSUFFICIENT DISCHARGE

- Air leaks in suction piping.
- Pump not primed.
- Discharge head higher than anticipated.
- Closed valve.
- Viscosity or specific gravity too high (magnets uncoupled).
- Suction lift too high or insufficient NPSH.
- Clogged suction line or impeller vanes.
- Motor rotation incorrect (correct rotation when viewed from the fan end is clockwise).

### INSUFFICIENT PRESSURE

- Air or gas in liquid.
- Impeller diameter too small.
- System head lower than anticipated.
- Motors speed insufficient (too low) or motor rotation incorrect (correct rotation when viewed from the fan end is clockwise).

### LOSS OF PRIME

- Leaking suction line.
- Foot valve or suction opening not submerged enough.
- Foot valve too small or leaking.
- Air or gas in liquid.
- Foreign matter in impeller.
- Leaking valve. Suction lift too high or insufficient NPSH.

### EXCESSIVE POWER CONSUMPTION

- Head lower than rating.
- Excessive flow.
- Specific gravity or viscosity too high.

### VIBRATION/NOISE

- Loose magnet.
- Drive magnet rubbing.
- Pump cavitation from improper suction or feed.
- Motor or piping not properly secured.
- Foreign object in impeller.

### CHEMICAL REACTION DISCLAIMER

#### IMPORTANT NOTICE

**U.S. Export Administration Regulations, pursuant to ECCN 2B350, prohibit the export or reexport to certain enumerated countries of sealless centrifugal pumps in which all wetted materials are constructed from fluoropolymers without first applying for and obtaining a license from the U.S. Bureau of Industry and Security (BIS). This affects all Finish Thompson magnetic-drive pumps constructed from PVDF or lined with ETFE. Please contact the BIS ([www.bis.doc.gov](http://www.bis.doc.gov)) or Finish Thompson with questions regarding the Regulations or a list of the countries to which they apply.**

The user must exercise primary responsibility in selecting the product's materials of construction, which are compatible with the fluid(s) that come(s) in contact with the product. The user may consult Finish Thompson, Inc. (manufacturer) and a manufacturer's representative/distributor agent to seek a recommendation of the product's material of construction that offers the optimum available chemical compatibility.

However neither manufacturer nor agent shall be liable for product damage or failure, injuries, or any other damage or loss arising out of a reaction, interaction or any chemical effect that occurs between the materials of the product's construction and fluids that come into contact with the product's internals.

### HELPFUL HINTS

Do not pump liquids containing ferrous metal fines.

If magnets de-couple, stop the pump immediately. The rare earth magnets used in this pump are more resistant to demagnetization, but operating the pump with the magnets de-coupled will eventually weaken the magnets.

A power monitor is strongly recommended. This device will help protect the pump against abnormal operating conditions such as dry running, magnet de-coupling, cavitation, etc.

Power monitors are required and must be used with all ATEX certified pumps.

The setting of the drive magnet dimension is critical. Failure to properly set the dimension may result in de-coupling or damage to pump components.

Do not use mismatched drive magnet assemblies (impeller drive magnet and the outer drive magnet assembly). The drives are marked with either an "A" or "B". Use only components with the same drive letter designation. A serial number plate is attached to the motor adapter section.

Call our toll free Technical Service Hot Line, 1-800-888-3743, if you have any questions regarding product operation or repair.

### ORDERING SPARE PARTS

Spare parts can be ordered from your local distributor. Always refer to the pump model number to avoid error.

### OTHER FINISH THOMPSON PUMP PRODUCTS

Drum Transfer Pumps are available in sanitary construction, Stainless steel, polypropylene and CPVC. Flows to 40 gpm, Discharge heads to 300 feet and viscosities to 100,000 cps.

Portable Mixers for turbine mixing and blending handle viscosities to 1,000 cP with gentle, non-vortexing circulation. Available in 316 stainless steel construction.

Centrifugal Pumps in polypropylene, PVDF, stainless steel, or Hastelloy C come with a wide variety of sealing materials. Flows to 330 gpm, discharge heads to 275 feet, and temperatures to 220°F (104°C)

For more information contact Finish Thompson Inc. Call our toll free Technical Service Hot Line, 1-800-888-3743, if you have any questions regarding product operation or repair.

### UCR11 EXPLODED VIEW PARTS DIAGRAM

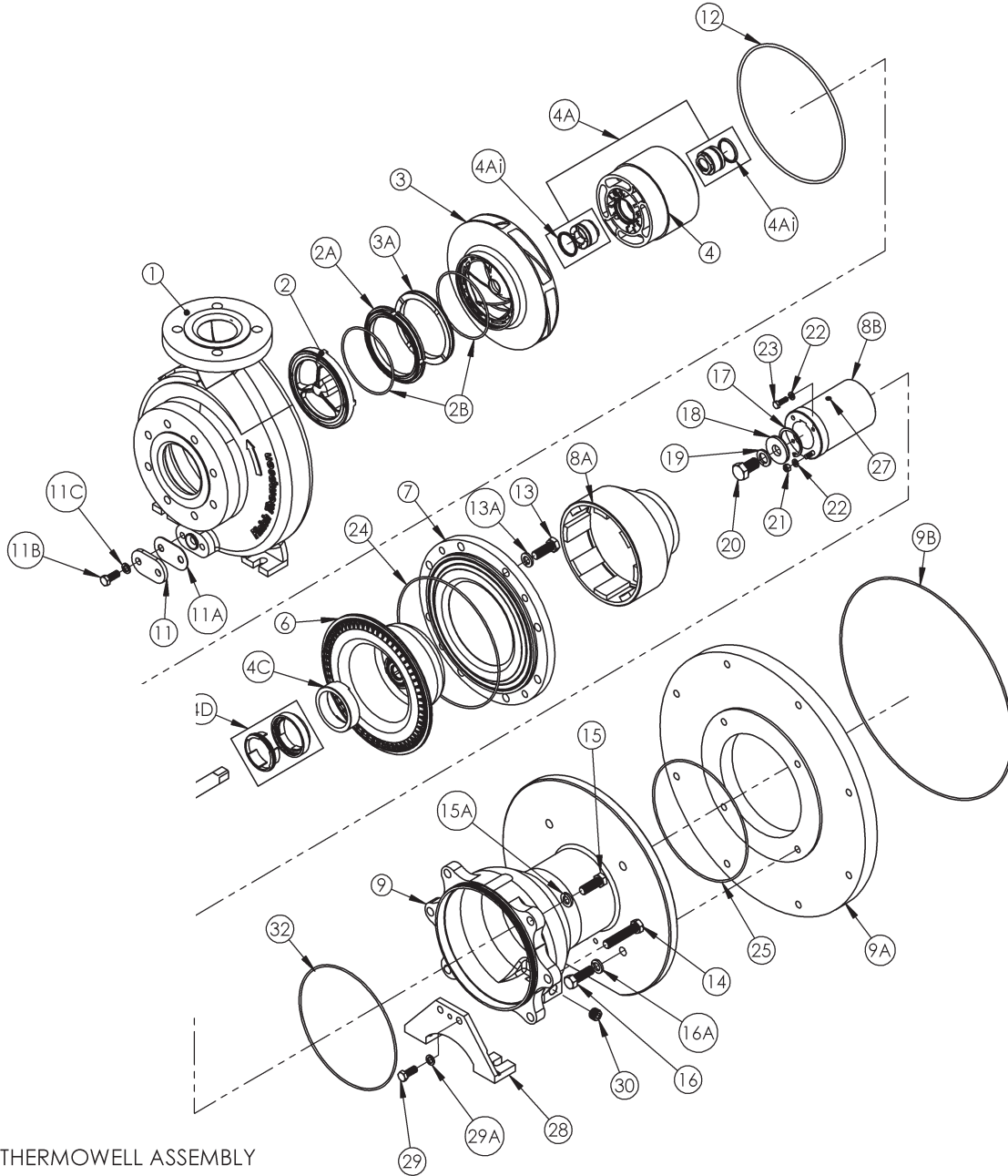

THERMOWELL ASSEMBLY

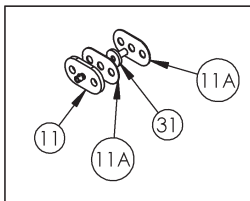

**Illinois Location:**  
 (847) 841-7867  
 1675 Todd Farm Dr.  
 Elgin, IL 60123

**Minnesota Location:**  
 (651) 758-7867  
 330 Mill Bay South Suite 1511  
 Afton, MN 55001

PumpSupplyInc.com

**PUMP SUPPLY**  
 INCORPORATED

<b>UCR II Models Spare Parts List</b> <b>Models 2110, 2110L, 3110, 3158, 328, 3210, 436, 438, 4310H, 6410</b>			
Item	Qty	Description	Part Number
1	1	<b>Casing - ETFE-lined, Painted Ductile Iron</b>	
		UCR2110 - 150# flange	107777-1
		UCR2110 - 300# flange	107777-2
		UCR2110 - ISO PN40 flange	107777-3
		UCR2110L - 150# flange	110364-1
		UCR2110L - 300# flange	110364-2
		UCR2110L - ISO PN40 flange	110364-3
		UCR3110 - 150# flange	108940-1
		UCR3110 - 300# flange	108940-2
		UCR3110 - ISO PN40 flange	108940-3
		UCR3158 - 150# flange	108252-1
		UCR3158 - 300# flange	108252-2
		UCR3158 - ISO PN40 flange	108252-3
		UCR328 - 150# flange	110153-1
		UCR328 - 300# flange	110153-2
		UCR328 - ISO PN40 flange	110153-3
		UCR3210 - 150# flange	110405-1
		UCR3210 - 300# flange	110405-2
		UCR3210 - ISO PN40 flange	110405-3
		UCR436 - 150# flange	111358-1
		UCR436 - 300# flange	111358-2
		UCR436 - ISO PN40 flange	111358-3
		UCR438 - 150# flange	108251-1
		UCR438 - 300# flange	108251-2
		UCR438 - ISO PN40 flange	108251-3
		UCR4310H - 150# flange	108982-1
		UCR4310H - 300# flange	108982-2
		UCR4310H - ISO PN40 flange	108982-3
UCR6410 - 150# flange	108989-1		
UCR6410 - 300# flange	108989-2		
UCR6410 - ISO PN40 flange	108989-3		
2	1	<b>Front Shaft Support Only (2A Sold Separately)</b>	
		UCR3158, 328, 3210, 436, 438	107666
		UCR2110, 2110L, 3110	107765
		UCR4310H	108976
		UCR6410	110097
2A	1	<b>Silicon Carbide Front Thrust Ring</b>	
		UCR3158, 328, 3210, 436, 438	107736
		UCR2110, 2110L, 3110	107989
		UCR4310H	108977
		UCR6410	110098
2B	2	<b>PTFE Encapsulated O-Ring</b>	
		UCR3158, 328, 3210, 436, 438 (UCR3210 only uses 1 o-ring for the shaft support)	108571
		UC2110, 2110L, 3110	N/A
		UCR4310H	110140
		UCR6410	110143
3	1	<b>Impeller Assembly w/ SiC Thrust Ring &amp; PTFE Encapsulated O-ring</b>	
		See Impeller Assembly Tables in the back of this price book	



Item	Qty	Description	Part Number
3A	1	<b>Silicon Carbide Impeller Thrust Ring</b>	
		UCR3158, 328, 436, 438	107737
		UCR2110, 2110L, 3110	107990
		UCR3210	110966
		UCR4310H	108978
		UCR6410	110099
4	1	<b>Impeller Drive Pure ETFE Encapsulated Magnets</b>	
		"B" Magnet 6-Pole - (Standard)	211848
		"C" Magnet 8-Pole - (Standard)	211848-1
		"D" Magnet 10-Pole - (Standard)	211848-2
		"E" Magnet 12-Pole - (Standard)	211848-3
		"F" Magnet 10-Pole - (Standard)	211849
4A	2	<b>Bushing (Bushings and Bushing Retainers)</b>	
		Silicon carbide	210210
		Carbon	210210-1
		Dri-Coat SiC	210210-2
4Ai	2	<b>Bushing Retainer</b>	
		Bushing Retainer	210212
4C	1	<b>Rear Sealing Ring - Moly-filled PTFE</b>	
		All UCRII Models	211280
		All UCRII 100HP (F magnet) models	211281
4D	1	<b>Retainer &amp; Locking Ring - ETFE (holds rear sealing ring in place)</b>	
		All UCRII Models (Excluding UCR648)	111470
5	1	<b>Shaft</b>	
		Silicon carbide	212023
		Dri-Coat SiC	212023-1
6	1	<b>Barrier Assembly - Pure ETFE Liner w/ Carbon Fiber Shell</b>	
		UCR3158, 328, 436, 438, 4310H, 6410 (Comes with 4C and 4D)	211528
		UCR2110, 2110L, 3110, 3210 (Comes with 4C and 4D)	211528-3
		100 HP (F magnet) - UCR3210 (Comes with 4C and 4D)	211529-4
		100 HP (F magnet) - UCR438, UCR4310H, UCR6410 (Comes with 4C and 4D)	211528-1
7	1	<b>Clamp Ring</b>	
		Painted ductile iron	211856
		100 HP (F magnet) - Painted ductile iron	211857
8A	1	<b>Outer Drive Magnet Hub</b>	
		"B" Magnet 6-Pole	108106-1
		"C" Magnet 8-Pole	108106-2
		"D" Magnet 10-Pole	108106-3
		"E" Magnet 12-Pole	108106-4
		"F" Magnet 10-Pole	110479

**Illinois Location:**  
 (847) 841-7867  
 1675 Todd Farm Dr.  
 Elgin, IL 60123

**Minnesota Location:**  
 (651) 758-7867  
 330 Mill Bay South Suite 1511  
 Afton, MN 55001

PumpSupplyInc.com



Item	Qty	Description	Part Number
8B	1	<b>Shaft Adapter (NEMA includes Retaining Ring &amp; Set Screws if used)</b>	
		NEMA 143-145TC	108665-1
		NEMA 182-184TC	108665-2
		NEMA 213-215TC	108665-3
		NEMA 254-256TC	108665-4
		NEMA 284-286TSC	108665-5
		NEMA 284-286TC	108665-6
		NEMA 324-326, 364-365TSC	108665-7
		NEMA 324-326TC	108665-8
		NEMA 364-365TC	108665-9
		NEMA 404-405TSC	108665-10
		IEC 90	108666-1
		IEC 100/112	108666-2
		IEC 132	108666-3
		IEC 160	108666-4
		IEC 180	108666-5
		IEC 200/225	108666-6
		IEC 250	108666-8
IEC 280	108666-9		
9	1	<b>Motor Adapter</b>	
		NEMA 143-145TC	107637
		NEMA 182-184TC, 213-215TC, 254-256TC	107637-1
		NEMA 284-286TSC/TC	107637-2
		NEMA 324-326TSC/TC, 364-365TSC/TC	107663
		NEMA 404-405TSC	110490
		IEC 90 B5	107637-3
		IEC 100/112 B5	107637-4
		IEC 132 B5	107637-5
		IEC 160/180 B5	107663-1
		IEC 200 B5	107663-2
		IEC 225 B5	107663-3
		IEC 250/280 B5	110490
		NEMA 143-145TC w/ non-sparking ring (ATEX)	108673-1
		NEMA 182-184TC, 213-215TC, 254-256TC w/ non-sparking ring (ATEX)	108673-2
		NEMA 284-286TSC/TC w/ non-sparking ring (ATEX)	108673-3
		NEMA 324-326TSC/TC, 364-365TSC/TC w/ non-sparking ring (ATEX)	108673-7
		NEMA 404-405TSC w/ non-sparking ring (ATEX)	108673-11
		IEC 90 B5 w/ non-sparking ring (ATEX)	108673-4
		IEC 100/112 B5 w/ non-sparking ring (ATEX)	108673-5
		IEC 132 B5 w/ non-sparking ring (ATEX)	108673-6
		IEC 160/180 B5 w/ non-sparking ring (ATEX)	108673-8
		IEC 200 B5 w/ non-sparking ring (ATEX)	108673-9
		IEC 225 B5 w/ non-sparking ring (ATEX)	108673-10
IEC 250-280 B5 w/ non-sparking ring (ATEX)	108673-11		
9A	1	<b>Motor Adapter Flange - Painted Steel</b>	
		IEC 250-280/ B5	111454
9B	1	<b>Vapor Protection O-Ring (Motor Adapter Flange to Motor)</b>	
		IEC 250-280/ B5	111462
11	1	<b>Drain Cap</b>	
		304 stainless steel	110254
		304 Thermowell Stainless Steel	212190
11A	1	<b>Drain Cap Gasket</b>	
		PTFE	108294
		PTFE, Thermowell Gasket	108294-1
	2		

Item	Qty	Description	Part Number
12	1	<b>Barrier O-ring</b>	
		FKM (s/n 144368 & above)	110144
		EPDM (s/n 144368 & above)	110145
		Kalrez #6375 (s/n 144368 & above)	110177
		Simriz #485 (s/n 144368 & above)	110178
		Aflas (s/n 144368 & above)	110146
		FEP encapsulated FKM (s/n 144368 & above)	110125
24	1	<b>Vapor Protection O-ring (Pump End)</b>	
		Buna	108594
25	1	<b>Vapor Protection Buna O-ring (Motor End)</b>	
		NEMA 143-145TC	106549
		NEMA 182-184TC, 213-215TC, 254-256TC	108165
		NEMA 284-286TSC & TC	108736
		NEMA 324-326, 364-365TSC & TC, 404-405TSC	108737
		IEC 90 B5	106572
		IEC 100/112 B5	108974
		IEC 132 B5	108589
		IEC 160 & 180 B5	108594
		IEC 200 B5	108738
		IEC 225 B5	108739
		IEC 250-280 B5	108737
28	1	<b>Foot - Painted Ductile Iron</b>	
		All models except UCR6410	107744
		UCR6410	108998
30	1	<b>Motor Adaptor Drain Plug</b>	
		Plug, 1/2" NPT 304SS	210644
31	1	<b>Thermowell</b>	
		SiC Thermowell	210246
32	1	<b>Motor Adapter Pump End Vapor Protection O-ring</b>	
		Buna , Dash 272	108572
		Buna, Dash 274 (Used with 100HP "F" Magnet Set)	212195

**Illinois Location:**  
 (847) 841-7867  
 1675 Todd Farm Dr.  
 Elgin, IL 60123

**Minnesota Location:**  
 (651) 758-7867  
 330 Mill Bay South Suite 1511  
 Afton, MN 55001

PumpSupplyInc.com



Hardware			
Item	Qty	Description	Part Number
11B	2	<b>Drain Cap Hex Head Bolts - Stainless Steel</b>	
		M12-1.75 x 30 mm hex head	106507
11C	2	<b>Drain Cap Lock Washer - Stainless Steel</b>	
		M12	106503
13	8	<b>Casing Hex Head Cap Screw - Stainless Steel</b>	
		M16-2 X 45 mm hex head	108675
13A	8	<b>Casing Lock Washers - Stainless Steel</b>	
		M16	107924
14	2	<b>Jack Bolt - Stainless Steel</b>	
		M16-2.0 x 80 mm	107102
15	4	<b>Motor Adapter Bolts - Stainless Steel</b>	
		M16-2 X 45 mm	108675
15A	4	<b>Motor Adapter Lock Washers - Stainless Steel</b>	
		M16	107924
16	4	<b>Motor Bolts - Stainless Steel</b>	
		NEMA 143-145TC, 3/8-16 x 1-1/2"	J103207
		NEMA 182-184, 213-215, 254-256, 284-286TSC or TC, 1/2-13 x 1-1/2",	J101858
		NEMA 324-326, 364-365TSC or TC, 404-405TSC, 5/8-11 x 1-1/2"	J100776
		IEC 90 B5, M10-1.5 x 30mm	105757
		IEC 100/112/132 B5, M12-1.75 x 35mm	105337
		IEC 160/180/200/225, M16-2.0 x 45 mm	108675
IEC 250/280, 5/8-11x2"	111463		
16A	4	<b>Motor Lock Washers - Stainless Steel</b>	
		NEMA 143-145TC, 3/8"	J100115
		NEMA 182-184, 213-215, 254-256, 284-286TSC or TC, 1/2"	J101023
		NEMA 324-326, 364-365TSC or TC, 5/8"	J104026
		IEC 90 B5, M10	105774
		IEC 100/112/132 B5, M12	106503
		IEC 160/180/200/225, M16	107924
IEC 250/280, 5/8	J104026		
17	1	<b>Retaining Ring</b>	
		NEMA 143-145TC, DHT-22	105709
		NEMA 182-184TC, DHT-28	105710
		NEMA 213-215TC, DHT-35	106454
		NEMA 254-256TC, DHT-42	106718
		NEMA 284-286TSC, DHT-42	106718
		NEMA 284-286TC, DHO-48	108667
		NEMA 324-326, 364-365TSC, DHO-48	108667
		NEMA 324-326TC, 404-405TSC, DHO-55	108668
		NEMA 364-365TC, DHO-60	108669
		IEC 90, DHT-24	105712
		IEC 100/112, DHT-28	105710
		IEC 132, DHT-38	106468
		IEC 160, DHT-42	106718
		IEC 180, DHO-48	108667
		IEC 200/225, DHO-55	108668
		IEC 250, DHO-60	108669
IEC 280, DHO-65	111459		

Item	Qty	Description	Part Number
18	1	<b>Shaft Adapter Washer (IEC Only)</b>	
		IEC 90	108383
		IEC 100	108383-1
		IEC 132	108383-2
		IEC 160	108383-3
		IEC 180	108383-4
		IEC 200/225	108383-5
		IEC 250	108383-7
19	1	<b>Shaft Adapter Lock Washer - Stainless Steel (IEC Only)</b>	
		IEC 90- 5/16	J102282
		IEC 100/112- M10	105757
		IEC 132- M12	106503
		IEC 160/180- M16	107924
20	1	<b>Shaft Adapter Bolt - Stainless Steel (IEC Only)</b>	
		IEC 90- M8-1.25 x 35 mm	J103662
		IEC 100/112- M10-1.5 x 30 mm	105774
		IEC 132- M12-1.75 x 30 mm	106507
		IEC 160/180- M16-2 x 35 mm	108270
		IEC 200/225- M20-2.5 x 35 mm	108690
21	2	<b>Drive Nut - Stainless Steel</b>	
		M8 Hex Nut	J103930
22	4	<b>Drive Lock Washers - Stainless Steel</b>	
		5/16"	J102282
23	2	<b>Drive Bolt - Stainless Steel</b>	
		M8-1.25 x 25mm	J103662
27	2	<b>Shaft Adapter Set Screw - Stainless Steel</b>	
		3/8-16 x 3/8 Knurled Cup Point	110112
29	2	<b>Foot Bolt - Stainless Steel</b>	
		M12-1.75 x 30mm	106507
29A	2	<b>Foot Lock Washer - Stainless Steel</b>	
		M12	106503
*	1	<b>Outer Drive Protection Tube</b>	
		Cardboard tube (for assembly use only)	108958-2

\*NOTE: For all IEC B5 motors, hardware to attach motor to motor adapter (Item 16 & 16A) is to be supplied by customer

\*\*Item not shown

**Illinois Location:**  
 (847) 841-7867  
 1675 Todd Farm Dr.  
 Elgin, IL 60123

**Minnesota Location:**  
 (651) 758-7867  
 330 Mill Bay South Suite 1511  
 Afton, MN 55001

PumpSupplyInc.com

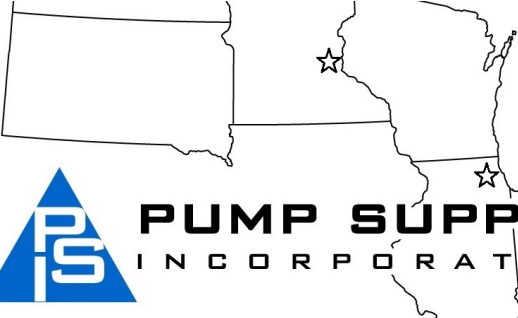



**PUMP SUPPLY**  
 INCORPORATED

<b>UCR2110,UCR2110L &amp; UCR3110 Impeller Part Numbers</b>	
<b>Includes SiC Thrust Ring</b>	
<b>Imp Dia.</b>	<b>Part Number</b>
10-1/2"	108241-1
10-3/8"	108241-2
10-1/4"	108241-3
10-1/8"	108241-4
10"	108241-5
9-7/8"	108241-6
9-3/4"	108241-7
9-5/8"	108241-8
9-1/2"	108241-9
9-3/8"	108241-10
9-1/4"	108241-11
9-1/8"	108241-12
9"	108241-13
8-7/8"	108241-14
8-3/4"	108241-15
8-5/8"	108241-16
8-1/2"	108241-17
8-3/8"	108241-18
8-1/4"	108241-19
8-1/8"	108241-20
8"	108241-21
7-7/8"	108241-22
7-3/4"	108241-23
7-5/8"	108241-24
7-1/2"	108241-25
7-3/8"	108241-26
7-1/4"	108241-27
7-1/8"	108241-28
7"	108241-29
6-7/8"	108241-30
6-3/4"	108241-31
6-5/8"	108241-32
6-1/2"	108241-33
6-3/8"	108241-34
6-1/4"	108241-35
6-1/8"	108241-36
6"	108241-37

<b>UCR3210 Impeller Part Numbers</b>	
<b>Includes SiC Thrust Ring</b>	
<b>Imp Dia.</b>	<b>Part Number</b>
10.50 "	110963-1
10.38 "	110963-2
10.25 "	110963-3
10.13 "	110963-4
10.00 "	110963-5
9.88 "	110963-6
9.75 "	110963-7
9.63 "	110963-8
9.50 "	110963-9
9.38 "	110963-10
9.25 "	110963-11
9.13 "	110963-12
9.00 "	110963-13
8.88 "	110963-14
8.75 "	110963-15
8.63 "	110963-16
8.50 "	110963-17
8.38 "	110963-18
8.25 "	110963-19
8.13 "	110963-20
8.00 "	110963-21
7.88 "	110963-22
7.75 "	110963-23
7.63 "	110963-24
7.50 "	110963-25
7.38 "	110963-26
7.25 "	110963-27
7.13 "	110963-28
7.00 "	110963-29
6.88 "	110963-30
6.75 "	110963-31
6.63 "	110963-32
6.50 "	110963-33
6.37 "	110963-34
6.25 "	110963-35
6.13 "	110963-36
6.00 "	110963-37



<b>UCR3158, UCR328 Impeller Part Numbers</b>	
<b>Includes SiC Thrust Ring and PTFE Encapsulated O-Ring</b>	
<b>Imp Dia.</b>	<b>Part Number</b>
8.25"	110965-1
8.13"	110965-2
8.00"	110965-3
7.88"	110965-4
7.75"	110965-5
7.63"	110965-6
7.50"	110965-7
7.38"	110965-8
7.25"	110965-9
7.13"	110965-10
7.00"	110965-11
6.88"	110965-12
6.75"	110965-13
6.63"	110965-14
6.50"	110965-15
6.38"	110965-16
6.25"	110965-17
6.13"	110965-18
6.00"	110965-19

<b>UCR436 Impeller Part Numbers</b>	
<b>Includes SiC Thrust Ring and PTFE Encapsulated O-Ring</b>	
<b>Imp Dia.</b>	<b>Part Number</b>
6.50"	110962-15
6.38"	110962-16
6.25"	110962-17
6.13"	110962-18
6.00"	110962-19
5.81"	110962-20
5.45"	110962-21

**Illinois Location:**  
 (847) 841-7867  
 1675 Todd Farm Dr.  
 Elgin, IL 60123

**Minnesota Location:**  
 (651) 758-7867  
 330 Mill Bay South Suite 1511  
 Afton, MN 55001

PumpSupplyInc.com

UCR4310H Impeller Part Numbers	
Includes SiC Thrust Ring and PTFE Encapsulated O-Ring	
Imp Dia.	Part Number
10.50 "	110875-1
10.38 "	110875-2
10.25 "	110875-3
10.13 "	110875-4
10.00 "	110875-5
9.88 "	110875-6
9.75 "	110875-7
9.63 "	110875-8
9.50 "	110875-9
9.38 "	110875-10
9.25 "	110875-11
9.13 "	110875-12
9.00 "	110875-13
8.88 "	110875-14
8.75 "	110875-15
8.63 "	110875-16
8.50 "	110875-17
8.38 "	110875-18
8.25 "	110875-19
8.13 "	110875-20
8.00 "	110875-21

UCR438 Impeller Part Numbers	
Includes SiC Thrust Ring and PTFE Encapsulated O-Ring	
Imp Dia.	Part Number
8.25"	108239-1
8.13"	108239-2
8.00"	108239-3
7.88"	108239-4
7.75"	108239-5
7.63"	108239-6
7.50"	108239-7
7.38"	108239-8
7.25"	108239-9
7.13"	108239-10
7.00"	108239-11
6.88"	108239-12
6.75"	108239-13
6.63"	108239-14
6.50"	108239-15
6.38"	108239-16
6.25"	108239-17
6.13"	108239-18
6.00"	108239-19

UCR438 Impeller Part Numbers	
Includes SiC Thrust Ring and PTFE Encapsulated O-Ring	
Imp Dia.	Part Number
8.25 "	110962-1
8.13 "	110962-2
8.00 "	110962-3
7.88 "	110962-4
7.75 "	110962-5
7.63 "	110962-6
7.50 "	110962-7
7.38 "	110962-8
7.25 "	110962-9
7.13 "	110962-10
7.00 "	110962-11
6.88 "	110962-12
6.75 "	110962-13
6.63 "	110962-14
6.50 "	110962-15
6.38 "	110962-16
6.25 "	110962-17
6.13 "	110962-18
6.00 "	110962-19



**Illinois Location:**  
 (847) 841-7867  
 1675 Todd Farm Dr.  
 Elgin, IL 60123

**Minnesota Location:**  
 (651) 758-7867  
 330 Mill Bay South Suite 1511  
 Afton, MN 55001

PumpSupplyInc.com

UCR6410 Impeller Part Numbers	
Includes SiC Thrust Ring and PTFE Encapsulated O-Ring	
Imp Dia.	Part Number
10.50 "	110867-1
10.38 "	110867-2
10.25 "	110867-3
10.13 "	110867-4
10.00 "	110867-5
9.88 "	110867-6
9.75 "	110867-7
9.63 "	110867-8
9.50 "	110867-9
9.38 "	110867-10
9.25 "	110867-11
9.13 "	110867-12
9.00 "	110867-13
8.88 "	110867-14
8.75 "	110867-15
8.63 "	110867-16
8.50 "	110867-17
8.38 "	110867-18
8.25 "	110867-19
8.13 "	110867-20
8.00 "	110867-21



**FINISH THOMPSON INC.**

921 Greengarden Road • Erie, PA 16501-1591 U.S.A.  
 Ph 814-455-4478 • Fax 814-455-8518  
 Email sales@finishthompson.com • www.finishthompson.com



Part Number 212181 Rev. 0, 03/08/2025