



# UCR SERIES

## MODEL UCR438 (4X3X8 - A70)



### UCR438 PERFORMANCE 3500 RPM, 60 Hz

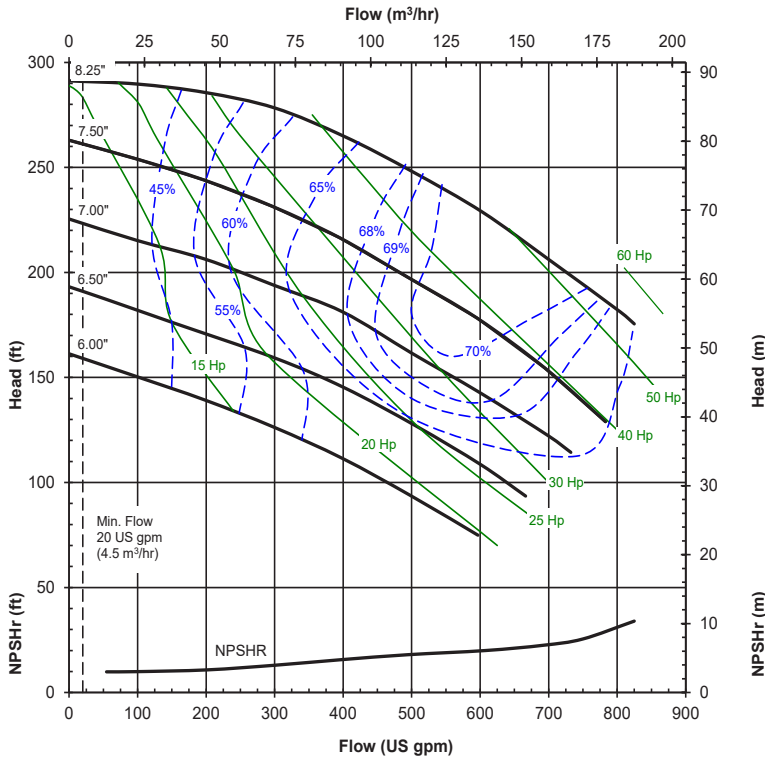

### UCR438 PERFORMANCE 2900 RPM, 50 Hz

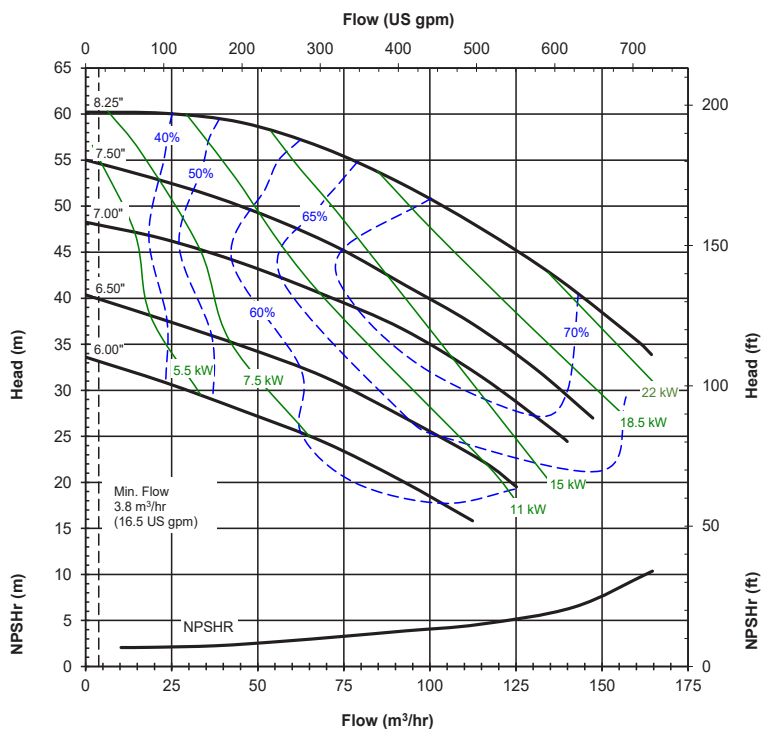

### FEATURES

- Durable, corrosion-resistant ETFE lined ductile iron casing
- Inner drive magnets are encapsulated in pure, unfilled ETFE and are 100% vacuum tested for guaranteed reliability and safety
- Barrier liner is pure unfilled ETFE for maximum protection against chemical permeation with carbon fiber reinforced exterior for exceptional strength
- All critical containment components are pure, unfilled ETFE for the ultimate in corrosion resistance
- Casing meets ANSI/ASME B73.1m & B73.3 for foot and flange location
- Powerful neodymium magnets transmit maximum torque
- Interchangeable single piece impeller and drive magnet is securely interlocked, yet allows independent impeller or drive replacement
- Volute with partial splitter reduces radial thrust load
- Axial thrust is managed with an annular orifice and balance holes
- Dual impeller bushings greatly reduce shaft load
- Suction shaft support with integral straightening vanes
- Easy-set measurement free outer drive
- Space saving vertical installation option with IEC motor
- Back pull-out design
- Exclusive vapor protection protects drive magnet and motor face from corrosive fumes
- Run dry capability with carbon or Dri-Coat (DLC) SiC bushing
- Casing drain standard
- 1/2" NPT motor adapter port with stainless steel plug
- Specific gravity over 1.8
- Accepts standard NEMA 143-405 or IEC 90-280 motor frames
- Maximum power 100hp/75kW
- ANSI 150, ANSI 300 or ISO PN40 flange mountable
- CE Certified, ATEX certified models available



# UCR SERIES

Item #	Description	Construction
1	Housing	Cast ductile iron, pure ETFE lined
2	Shaft support	Carbon fiber filled ETFE (CF-ETFE)
2A	Front thrust ring	Alpha sintered silicon carbide
3	Impeller	Carbon fiber filled ETFE (CF-ETFE)
3A	Impeller thrust ring	Fluorosint® or alpha sintered silicon carbide
4	Inner drive	Neodymium iron boron magnets encapsulated in pure, unfilled ETFE
4A	Bushing	Alpha sintered silicon carbide, Dri-Coat silicon carbide, or carbon
4B	Bushing retaining ring	PTFE
5	Shaft	Alpha sintered silicon carbide
6	Barrier	Molded pure, unfilled ETFE liner with carbon-fiber reinforced epoxy outer shell
6A	Barrier thrust ring	Alpha sintered silicon carbide
6B	Sealing ring	GF molybdenum disulfide-filled PTFE
7	Clamp ring	Powder coated ductile iron
8	Outer drive	Nickel plated neodymium iron boron magnets/ ductile iron
9	Motor adapter	Powder coated ductile iron
10	O-ring	FEP-encapsulated FKM, FKM, EPDM, Kalrez®, or Simriz®
11	Vapor Protection O-Rings	Buna N

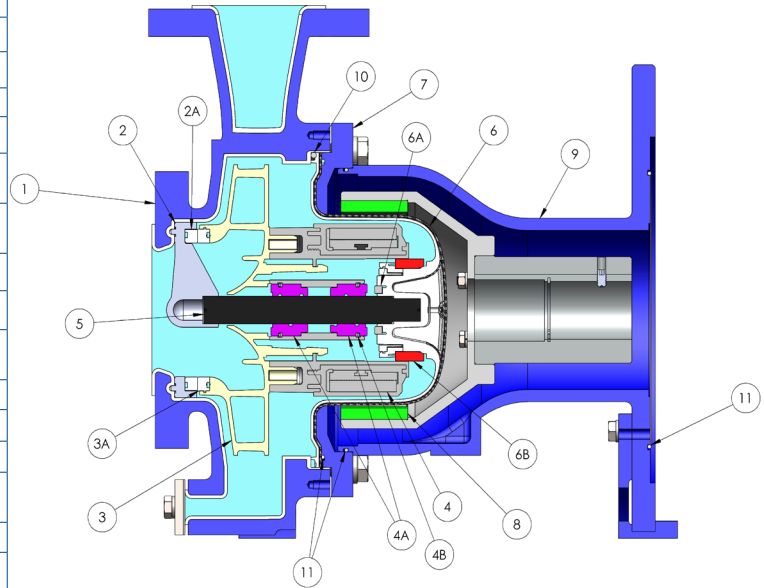

Kalrez® is a registered trademark of DuPont Performance Elastomers  
 Simriz® Perfluoroelastomer is a registered trademark of Simrit® division of Freudenberg-NOK.  
 Atlas® is a trademark of the Asahi Glass Co., Ltd.

## SPECIFICATIONS

HP (kW)	Impeller Diameter	Suction	Discharge	Max. Flow 3500 rpm		Max. Head 3500 rpm		Max. Working Pressure psi (Bar)	Max. Viscosity cP	Max. Specific Gravity	Max. Temp.* °F (°C)
	in (cm)	in (cm)	in (cm)	gpm	m <sup>3</sup> /hr	ft.	m				
1 - 100 (1.5 - 75)	6 - 8 1/4 (15.2 - 21)	4 (10.2)	3 (7.6)	825	187	290	88	300 (21)	200	1.8	250 (121)

\*Except E magnet set: maximum 220° F (104° C)  
 Note: Impeller trims available every 1/8" (.32 cm) between the smallest and largest diameters.

## DIMENSIONS

### FRONT VIEW

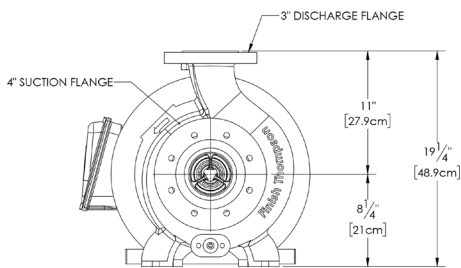

ANSI 150#, 300#, & ISO/DIN PN40 flanges are in compliance with bolting dimensions only.

### SIDE VIEW

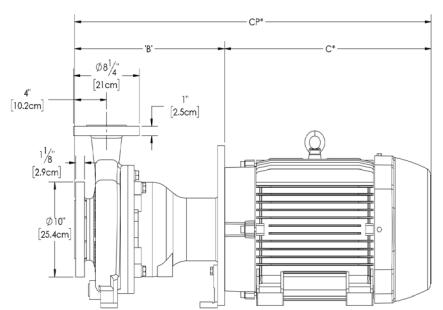

### BOTTOM VIEW

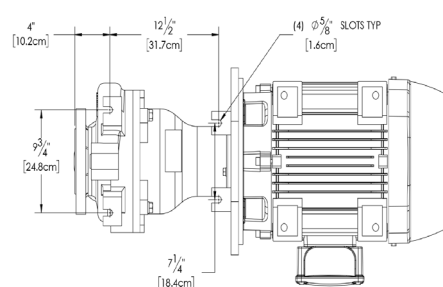

Motor Frames	CP (approx.)	
	in	cm
<b>NEMA</b>		
143-145TC	27-11/16	70.3
182/184TC	29-9/16	75.1
213/215TC	32-5/8	82.9
254/256TC	37-1/2	95.3
282/284TC/TSC	39-27/32	101.2
324/326TC/TSC	44-21/32	113.4
364/365TC/TSC	46-27/32	119.0
404/405 TSC	50-5/16	127.8
<b>IEC</b>		
90	27-15/32	69.8
100/112	28-29/32	73.4
132	32-9/16	82.7
160	38-9/32	97.2
180	40-9/16	103
200	43-3/32	109.5
225	46-21/32	118.5
250	52-17/32	133.4
280	56-3/4	144.1



finishthompson.com

### FINISH THOMPSON INC. - HEADQUARTERS

921 Greengarden Road | Erie, PA 16501  
 800.934.9384 | ph 814.455.4478 | fx 814.455.8518  
 email sales@finishthompson.com

### FINISH THOMPSON INC. - EUROPE CENTER

Otto-Hahn-Strasse 16 | Maintal, D-63477 Germany  
 49 (0)6181-90878-0 | fx 49 (0)6181-90878-18  
 email europecenter@finishthompson.com