



UCR SERIES

MODEL UCR436L (4X3X6)



UCR436L PERFORMANCE 3500 RPM, 60 Hz

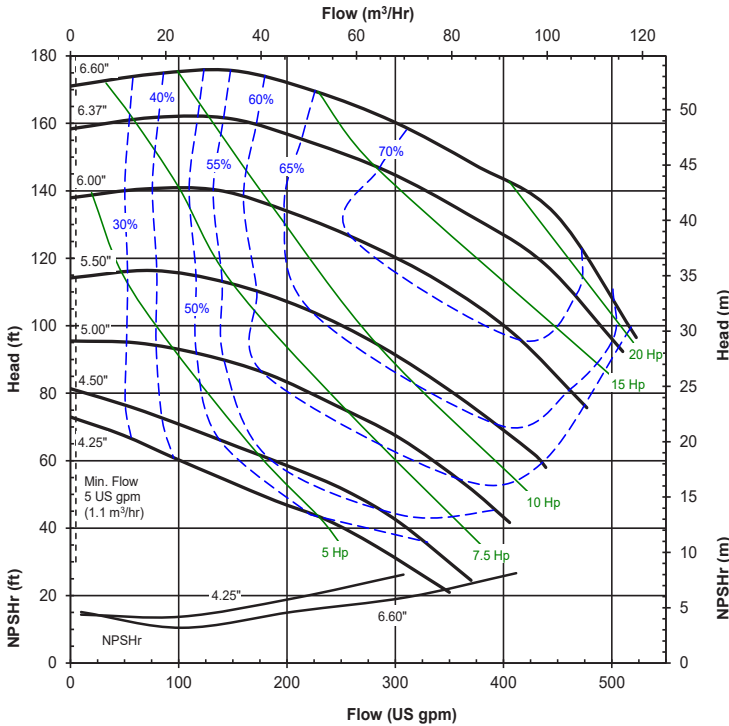

Impeller trims are available in 1/8" (.32 cm) diameter increments between all curves

UCR436L PERFORMANCE 2900 RPM, 50 Hz

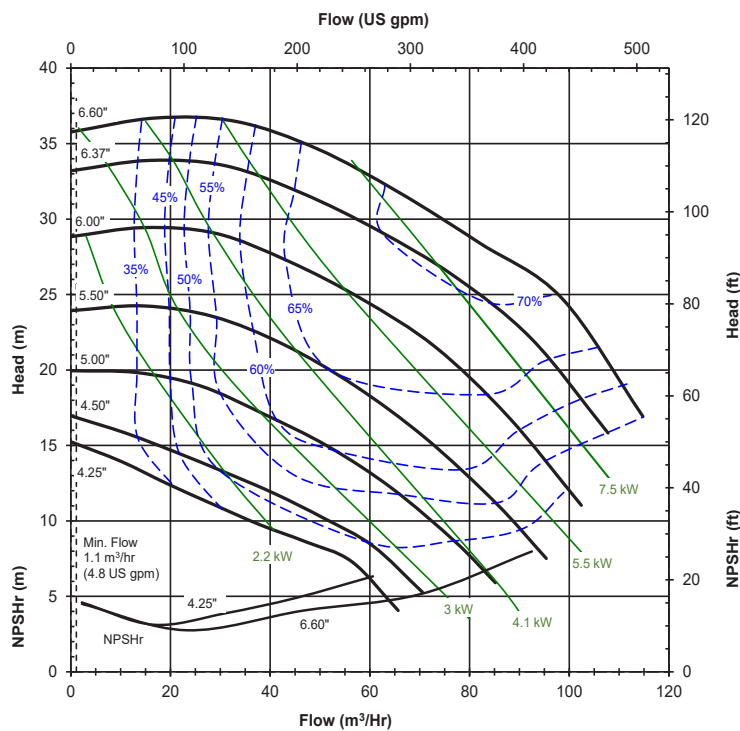

Impeller trims are available in 1/8" (.32 cm) diameter increments between all curves

FEATURES

- Durable, corrosion-resistant ETFE lined ductile iron casing
- Inner drive magnets are encapsulated in pure, unfilled ETFE and are 100% vacuum tested for guaranteed reliability and safety
- Barrier liner is pure unfilled ETFE for maximum protection against chemical permeation with carbon fiber reinforced exterior for exceptional strength
- All critical containment components are pure, unfilled ETFE for the ultimate in corrosion resistance
- Powerful neodymium magnets transmit maximum torque
- Interchangeable single piece impeller and drive magnet is securely interlocked, yet allows independent impeller or drive replacement
- Axial thrust is managed with an annular orifice and balance holes
- Dual impeller bushings greatly reduce shaft load
- Suction shaft support with integral straightening vanes
- Easy-set measurement free outer drive
- Space saving vertical installation option with IEC motor
- Back pull-out design
- Exclusive vapor protection protects drive magnet and motor face from corrosive fumes
- Run dry capability with carbon or Dri-Coat (DLC) SiC bushing
- Casing drain standard
- 1/2" NPT motor adapter port with stainless steel plug
- Specific gravity over 1.8
- Accepts standard NEMA 143-286 or IEC 90-160 motor frames
- Maximum power 30hp/22kW
- ANSI 150, ANSI 300 or ISO PN40 flange mountable
- CE Certified, ATEX certified models available



UCR SERIES

Item #	Description	Construction
1	Housing	Cast ductile iron, pure ETFE lined
2	Shaft support	Carbon fiber filled ETFE (CF-ETFE)
2A	Front thrust ring	Alpha sintered silicon carbide
3	Impeller	Carbon fiber filled ETFE (CF-ETFE)
3A	Impeller thrust ring	Fluorosint® or alpha sintered silicon carbide
4	Inner drive	Neodymium iron boron magnets encapsulated in pure, unfilled ETFE
4A	Bushing	Alpha sintered silicon carbide, Dri-Coat silicon carbide, or carbon
4B	Bushing retaining ring	PTFE
5	Barrier	Molded pure, unfilled ETFE liner with carbon-fiber reinforced epoxy outer shell
5A	Barrier thrust ring	Alpha sintered silicon carbide
5B	Sealing ring	GF molybdenum disulfide-filled PTFE
5C	Sealing ring retainer	Carbon fiber filled ETFE (CF-ETFE)
5D	Sealing ring lock	Carbon fiber filled ETFE (CF-ETFE)
6	Clamp ring	Powder coated ductile iron
7	Outer drive	Nickel plated neodymium iron boron magnets/ ductile iron
8	Motor adapter	Powder coated ductile iron
9	Shaft	Alpha sintered silicon carbide
10	O-ring	FEP-encapsulated FKM, FKM, EPDM, Kalrez®, or Simriz®
11	Vapor Protection O-Rings	Buna N

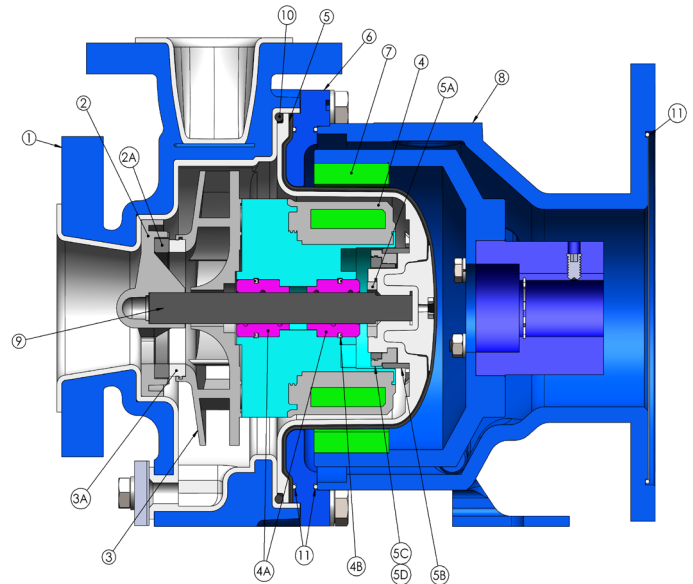

Kalrez® is a registered trademark of DuPont Performance Elastomers
 Simriz® Perfluoroelastomer is a registered trademark of Simriz® division of Freudenberg-NOK.
 Fluorosint® is a registered trademark of Quadrant DSM Engineering Plastic Products.

SPECIFICATIONS

HP (kW)	Impeller Diameter	Suction	Discharge	Max. Flow 3500 rpm		Max. Head 3500 rpm		Max. Working Pressure psi (Bar)	Max. Viscosity cP	Max. Specific Gravity	Max. Temp. °F (°C)
	in (cm)			gpm	m ³ /hr	ft.	m				
3 - 30 (1.1 - 22.0)	4-1/4 - 6 5/8 (10.8 - 16.8)	4 (10.2)	3 (7.62)	450	102	175	53.3	300 (21)	200	1.8	250 (121)

Note: Impeller trims available every 1/8" (.32 cm) between the smallest and largest diameters.

DIMENSIONS

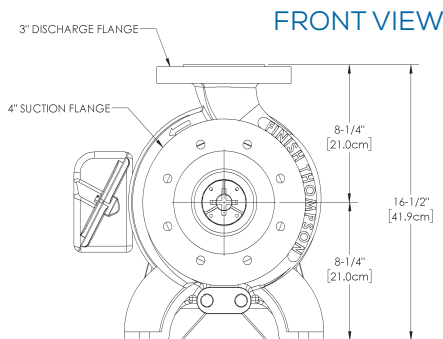

ANSI 150#, 300#, & ISO/DIN/PN40 flanges are in compliance with bolting dimensions only.

SIDE VIEW

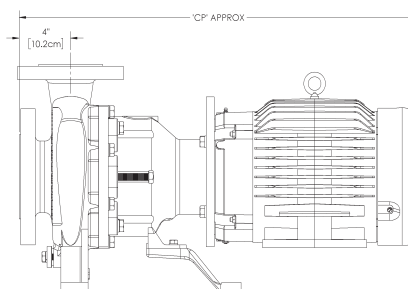

BOTTOM VIEW

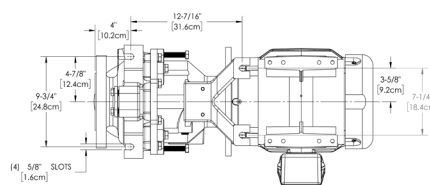

Motor Frames	CP (approx.)	
	(in)	(cm)
NEMA		
143-145TC	23-3/4	60
182/184TC	27-13/32	70
213/215TC	31-1/16	79
254/256TC	35-1/16	89
284/286TSC	38-13/32	98
IEC		
90 B14/B5	23-25/32	60
100/112 B14	25-7/32	64
100/112 B5	27-21/32	70
132 B5	31-5/16	80
160 B5	35-1/32	89



finishthompson.com

FINISH THOMPSON INC. - HEADQUARTERS

921 Greengarden Road | Erie, PA 16501
 800.934.9384 | ph 814.455.4478 | fx 814.455.8518
 email sales@finishthompson.com

FINISH THOMPSON INC. - EUROPE CENTER

Otto-Hahn-Strasse 16 | Maintal, D-63477 Germany
 49 (0)6181-90878-0 | fx 49 (0)6181-90878-18
 email europecenter@finishthompson.com