

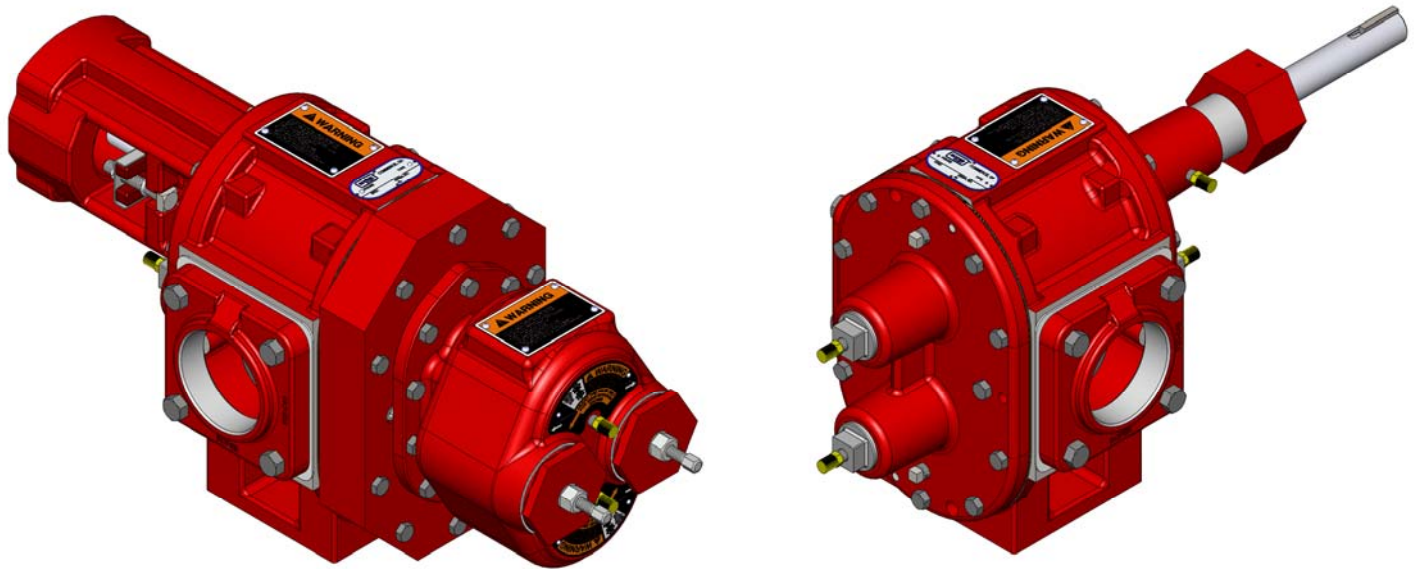

5600 SERIES OWNERS MANUAL

G12-405

10/30/17



SAFETY INSTRUCTIONS

This is an industrial component. Only a qualified systems integrator should be allowed to design it into a system. The integrator must determine proper plumbing, mounting, driveline and guard components.

Improper installation or use could lead to a serious, even fatal, accident. The system integrator must communicate all safe operation procedures to the end user(s).

Before operation, fully understand and follow the instructions shown in this manual and any instructions communicated by the system integrator. No one should be allowed to operate or maintain this pump that has not been fully trained to work safely according to the configuration of the pump system and in accordance with all applicable government and industry regulations.

DO NOT paint over nameplates, ID tags or warning tags.

Confidential & Proprietary: This document contains confidential and proprietary information which is the exclusive property of Roper Pump Company, Commerce, GA. U.S.A. and shall not be reproduced, communicated, disclosed, or disseminated in any manner to third parties or used for any purpose other than its intended purpose without prior written consent of the management of Roper Pump Company.

Roper Pump Company
P.O. Box 269
Commerce, GA 30529 USA

Telephone: (706) 335-5551
TeleFAX: (706) 335-5490
Email: sales@roperpumps.com
www.roperpumps.com

Table of Contents

Section	Page
1. Warnings & General Guidelines.....	3
2. Nameplate Data	5
3. Maximum Pump Ratings.....	7
4. Preoperational Checks.....	7
5. Recommended Tool List.....	7
6. Direction of Rotation & Relief Valves	8
7. High To Low Drive	11
8. Instructions For Draining The Pump	12
9. Instructions For Pump Disassembly.....	13
10. Bearing Removal And Installation	14
11. Instructions For Pump Assembly	15
12. Parts List & Cross Sectionals.....	17
13. Shaft Sealing	21
14. Lubrication	21
15. Index.....	22

1. WARNINGS & GENERAL GUIDELINES

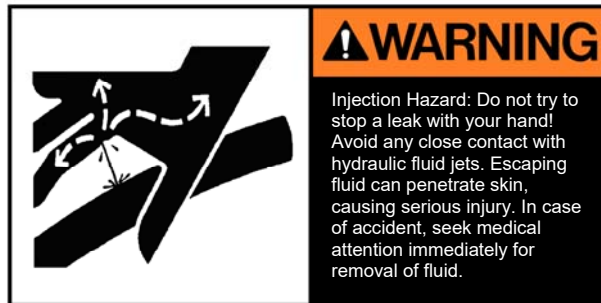
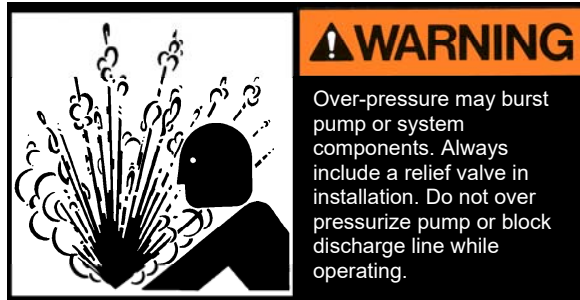

WARNING: DO NOT paint over any nameplates, ID tags, or warning tags attached to the pump.

NOTICE: These are general guidelines and do not cover all possible situations. It is the responsibility of the system integrator to apply this product properly.

- **System Pressure & Hazardous Fluids**

1. Disconnecting fluid or pressure containment components during pump operation can cause property damage, serious personal injury, or death.
2. Failure to relieve system pressure prior to performing pump service or maintenance can cause property damage, serious personal injury or death.
3. If pumping hazardous or toxic fluids, system must be flushed and decontaminated, inside and out, prior to performing service or maintenance.

- **Plumbing**

1. The inlet pipe should be as short and straight as possible to minimize suction pressure losses. Excessive restrictions at the inlet can cause cavitation resulting in poor performance, noise, vibration, or pump damage.
2. Slope the inlet plumbing appropriately to avoid air pockets.
3. Plumbing weight, misalignment with the ports or thermal expansion can exert excessive force on the pump. Plumbing must be properly supported and aligned with expansion joints, if required, to minimize these forces.
4. To prevent over pressure situations, install a relief valve as close to the pump outlet as possible. Install the relief valve before any shut-off valves.

DO NOT use Thread Seal (Teflon®) tape on pump port threads.

Teflon® is a registered trademark of E.I. DuPont de Nemours Co., Inc.



WARNING: DO NOT paint over any nameplates, ID tags, or warning tags attached to the pump.

- **Mounting Base**

1. Mount the unit on a rigid, heavy base to provide support and absorb shock. Bases should be designed for high rigidity; not just strength.
2. The pump feet were not designed for mounting to concrete and do not have enough contact area to prevent concrete from failing. When mounting to cement or concrete, use a steel baseplate to distribute the mounting stress over an area large enough to prevent the cement from failing. Grout it in place.

- **Pump and Drive Assemblies**

1. Assure adequate guards have been installed to prevent personnel contacting moving components.
2. Follow all OSHA, Federal, State, and local codes.

- **Check Alignment of Pump to Driveline**

Excessive misalignment can overload the pump input shaft and cause premature failure. The figures below show parallel and angular misalignments.

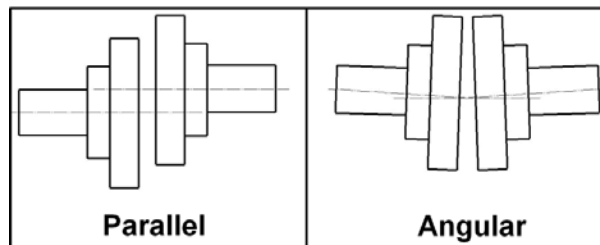

Figure 1-1: Coupling Alignment

- **Roper Pumps' Close Coupled Drives**

The hydraulic or gearmotor units mount directly to the pump.

- Alignment between pump and driveline is maintained by the assembly.

Because the assembly absorbs reaction forces of the driveline, the mounting base does not need to be as robust. The level of rigidity and strength is determined by the piping stresses from the system

- **Guarding PTO Drive Shafts**

PTO drive systems can be dangerous and when used, additional safety precautions, including guarding, is required and must be provided by the drive system installer. Roper Pump Company has no responsibility for recommending or providing proper guarding or other safety measures in any particular application.

NOTICE: The installation of proper guards for the power take-off and its associated equipment is the responsibility of the drive system designer and the installer who know the particular product application and the user's exposure to danger. *The ultimate responsibility for the safe application and installation is the user's.*

WARNING: Failure to stop the pump before adjusting the shaft packing can cause serious injury or death.

2. NAMEPLATE DATA

Roper Pump Company identifies each pump manufactured by a metal nameplate attached to the pump. This nameplate describes the pump as built at the factory. Copy the nameplate data from your pump in the area provided below. Use this for ready reference when ordering repair parts or when consulting with a Roper distributor or Roper Pump Company about this pump.

WARNING: DO NOT paint over any nameplates, ID tags, or warning tags attached to the pump.

MODEL NUMBER: _____
SPEC NUMBER: _____
TYPE NUMBER: _____
SERIAL NUMBER: _____

PUMP NOMENCLATURE

MODEL 5658BHFBVLW

SPEC XXXXX TYPE 1

SERIAL NO. ZZZ

1. The Model Number consists of a several digit number.
 - The first digit (5) indicates the series.
 - The second digit (6) indicates shaft sealing.
 - 5 - Triple Lip Seal
 - 6 – Packing Rings
 - The third and fourth digits (58) indicate the approximate theoretical displacement in U.S. gallons per 100 revolutions.
58gpm [219.6 liters] = .58 gpr x100rpm
 - The fifth and sometimes sixth digits (BH) indicates the pump head arrangement.
 - H - Pump with inboard bushing (Shaft Sealing: Packing Rings Only)
 - BH - Pump with mounting provisions for SAE hydraulic motor (Shaft Sealing: Packing & Triple Lip Seal)
 - The seventh digit (F) indicates port style.
 - F - Pump with Roper standard flange ports
 - The eighth and ninth digits (BV) indicate the type faceplate on the pump.
 - No letters – plain faceplate
 - BV- bi-directional relief valve faceplate
 - The letter(s) (LW) indicates shaft position.
 - No letter - High drive, Clockwise Rotation (W rotation is standard)
 - LW - Low drive, Clockwise Rotation
 - Z - High Drive, Counter Clockwise Rotation
 - LZ - Low Drive, Counter Clockwise Rotation

Example:

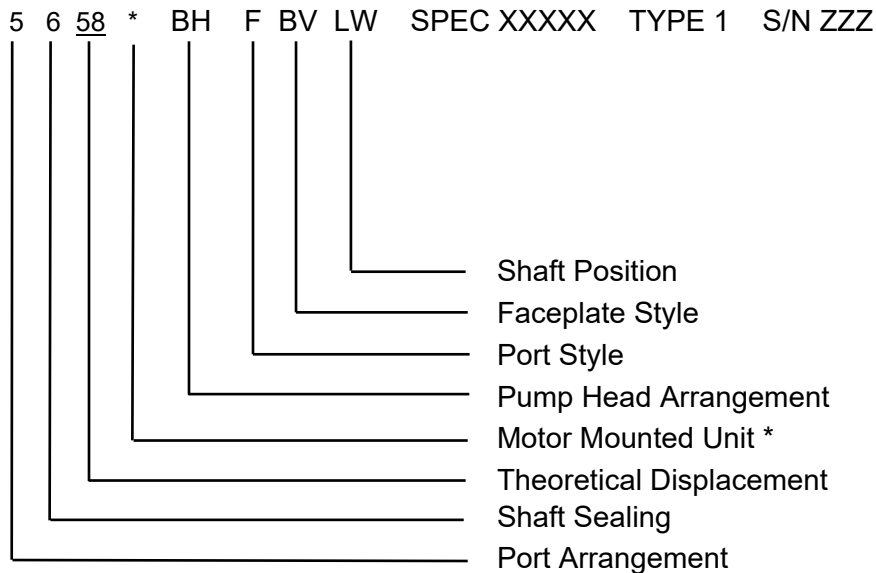

- * **The letter (M) may be used in this space indicating the pump is mounted on a base with or without motor. The letter (E) may be used in this space indicating the pump is mounted on a base with or without engine.**

As stated in the explanation of the pump nomenclature, all characters may not appear on every pump nameplate.

NOTICE: The preceding description of the figure number is to assist in identifying your Roper 5600 series pump only. **DO NOT** attempt to derive any ratings or performance from the figure number. **DO NOT** use the explanation of the Figure Number to construct your own pump. Not all combinations are possible. For assistance in pump selection, it is recommended that you consult Roper Pump Company or an authorized distributor.

2. Occasionally, special pumps or configurations are required which are unique for a particular application. These modifications are denoted by a SPEC number. Identification of any items different than a standard pump can be made by consulting Roper Pump Company or an authorized distributor.
3. The TYPE number is a number used by Roper Pump Company for in-house identification of construction and hydraulics. Always include the Type Number in any references to the pump.
4. The SERIAL number is a unique number assigned to each pump built by Roper Pump Company.

In any communication concerning this pump, always be sure to include the Figure, Spec, Type, and Serial numbers so proper identification of the pump can be assured.

3. MAXIMUM PUMP RATINGS

The maximum pressure, speed, and temperature limits for this pump SERIES are shown below.

The maximum rating of a pump with a SPEC number may be different depending on the materials of construction.

Maximum limits for this SERIES:

Pressure

- 100 psi [689 kPa] Maximum Inlet
- 100 psi [689 kPa] Maximum Discharge
- 99 psi [683 kPa] Maximum Differential

Speed

- 400 rpm Maximum

Temperature

- 160°F [71°C] Maximum

4. PREOPERATIONAL CHECKS

Read and understand the instructions and recommendations contained in this manual.

Disconnect the coupling between the driver and pump.

Test the rotation of the driver to make sure it will operate the pump in the desired direction of rotation. Rotation is shown on the pump faceplate if the pump has an integral relief valve. When an integral relief valve is used, make sure it is positioned and adjusted as discussed in Section 6, **DIRECTION OF ROTATION & RELIEF VALVES**. After the unit is mounted and the piping is connected, the pump should be checked to be sure it operates freely without binding. After operation is proved satisfactory, both pump and driver should be tightly secured and the alignment rechecked before operation.

Before starting, make sure all guards are in place and the inlet and discharge valves are opened.

Once starting the unit, check to see that the pump is delivering liquid. If not, stop the driver immediately and correct the problem. After the pump is delivering liquid, check the unit for excessive vibration, localized heating, and excessive shaft seal leakage. Check the pressure or vacuum by installing gauges at both the inlet and discharge sides of the pump to make sure the pressure or vacuum conforms to specifications.

5. RECOMMENDED TOOL LIST (Tools not supplied with pumps)

Tools for all Pumps:

- (1) Safety Glasses
- (1) 7/16" Combination Wrench
- (1) 3/4" Combination Wrench
- (1) 18" Pipe Wrench
- (1) Pliers
- (1) Packing hook
- (1) 5/8" Combination Wrench
- (1) 5/16" Hex Head Driver (Allen Wrench)

6. DIRECTION OF ROTATION & RELIEF VALVES

There are two types of faceplate assemblies available. The standard plain faceplate and the bi-directional relief valve faceplate, which is designated by the letters "BV" in the pump nomenclature. SPEC numbers are used to help identify some non-standard relief valves.

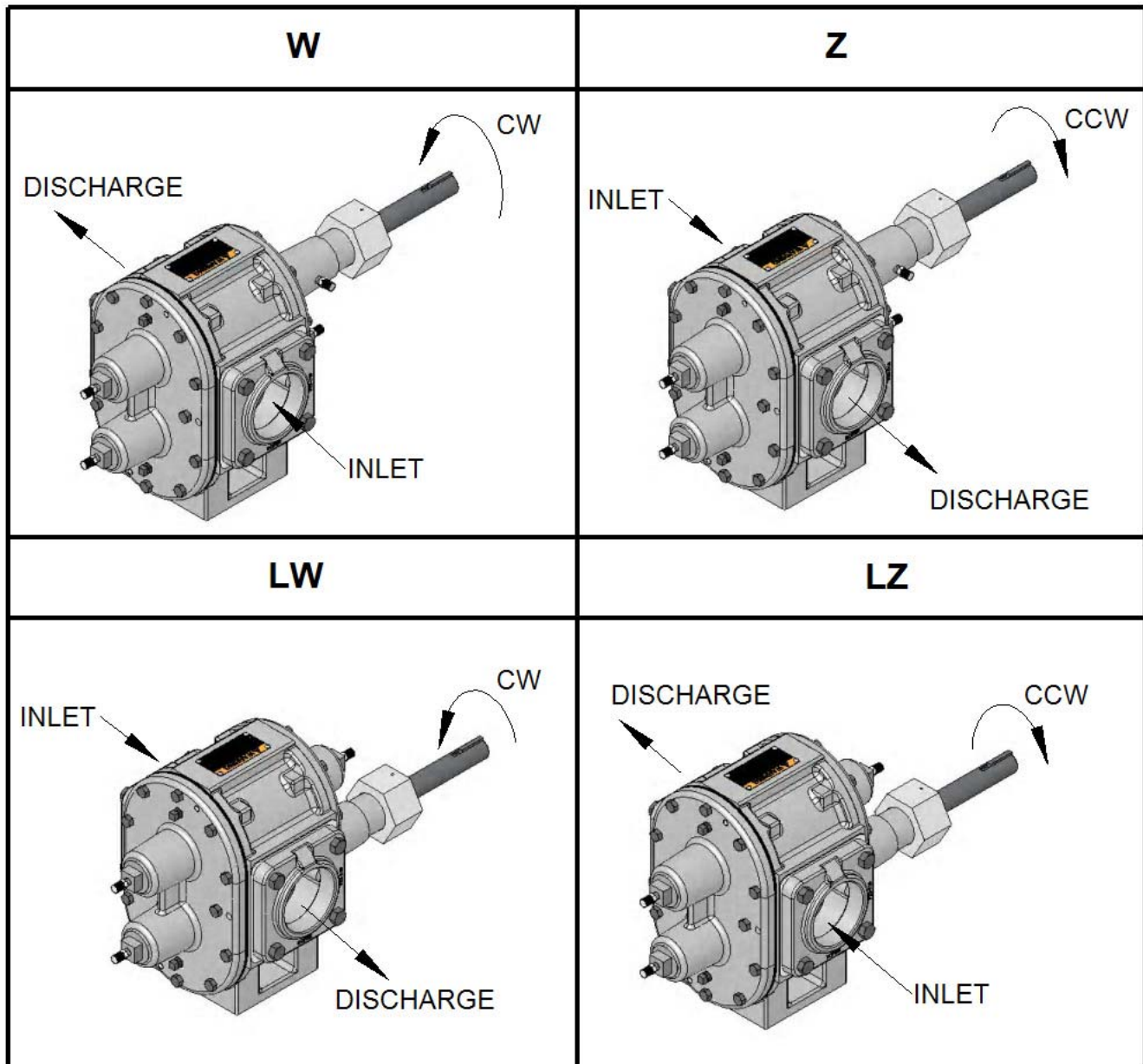

DIRECTION OF ROTATION FOR HIGH DRIVE & LOW DRIVE PUMP CONFIGURATIONS
(The bi-directional relief valve faceplate will have the same rotations, the plain faceplate is shown)

Figure 6.1

BI-DIRECTIONAL BV

This relief valve is externally adjustable by means of adjusting screws located in the center of the relief valve caps. The range of adjustment is approximately 30 psi [207 kPa] to 100 psi [689 kPa]. The actual capability is dependent on pump speed and liquid viscosity. The settings are for full bypass; that is, all of the fluid is circulating back to the inlet through the relief valve. The end user must set the relief valves for conditions that exactly match the application.

DIRECTION OF ROTATION TAG



Figure 6.2

WARNING: DO NOT paint over any nameplates, ID tags, or warning tags attached to the pump.

PROPER PUMP GEAR ROTATION

Proper gear rotation is shown on the warning tag attached to the bi-directional relief valve faceplate.

PUMP INLET and PUMP DISCHARGE

The “pump inlet” and “pump discharge” arrows will always point directly to the inlet and discharge ports on the pump with straight through port case.

NOTICE: An integral relief valve should not be used on applications where the discharge must be closed for more than one minute. Prolonged operation of the pump with the discharge closed will cause rapid heating of the liquid circulating through the relief valve, thus resulting in possible damage.

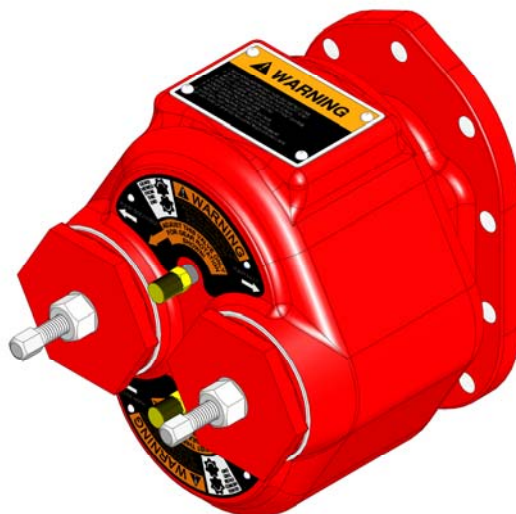

Figure 6.3

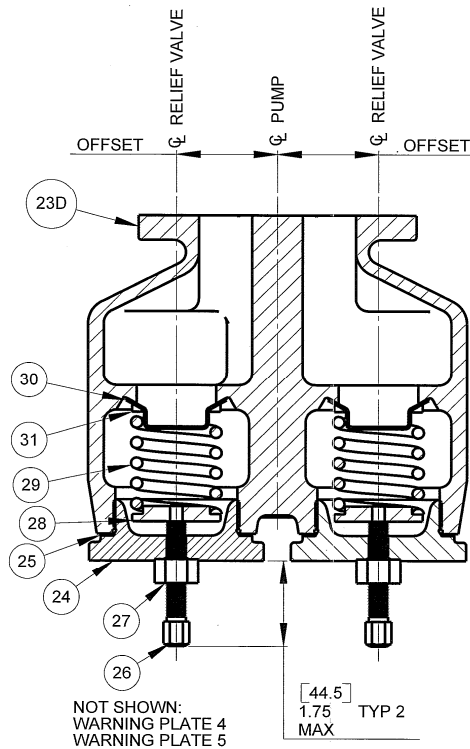

Figure 6.4

DISASSEMBLY OF THE BI-DIRECTIONAL RELIEF VALVES

Refer to the sectional drawing shown in Figure 6.4

1. Turn off pump and lock out energy source to driver.
2. Close inlet and discharge valves.
3. To drain pump, follow the procedure in Section 8, **INSTRUCTIONS FOR DRAINING PUMP**.
4. Decrease pressure on spring (29) by loosening lock and seal nut (27) and unscrewing adjusting screw (26) until adjusting screw turns freely.
5. After decreasing pressure on spring (29), remove the relief valve cap (24) by unscrewing it from the bi-directional relief valve faceplate assembly (45B).
6. Remove spring (29), poppet (30), spring washer (31), and spring guide (28).
7. Inspect all parts and replace worn or damaged parts as required.

ASSEMBLY OF THE BI-DIRECTIONAL RELIEF VALVES

Refer to the sectional drawing shown in Figure 6.4

1. Install poppet (30) into faceplate (45B).
2. Install spring (29) into faceplate (45B) making sure spring is centered on poppet (30) and resting on spring washer (31).
3. Place pilot of spring guide (28) into I.D. of spring (29).
4. Screw adjusting screw (26) with lock and seal nut (27) assembled into hole in relief valve cap (24).
5. Place small end of adjusting screw (26) in hole in spring guide (28) and screw relief valve cap (24) into the bi-directional relief valve faceplate assembly (45B).
6. Adjust relief valve by following steps shown in how **TO ADJUST THE BI-DIRECTIONAL RELIEF VALVES**

TO ADJUST THE BI-DIRECTIONAL RELIEF VALVES

Refer to the sectional drawing shown in Figure 6.4

WARNING: Take necessary precautions to prevent personal injury or physical damage that could be caused by any loss of the product being pumped while adjusting the relief valve. **DO NOT** adjust the relief valve without coupling guards in place.

NOTICE: The relief valves must be adjusted under conditions identical to the operating conditions (viscosity, rpm, etc.)

1. Connect an appropriate pressure gauge in the discharge line between pump and point where discharge line will be closed.
2. Loosen the locknut (27) on the adjusting screw (26).
3. Back the adjusting screw (26) out to point where end of adjusting screw will be 1-3/4 inches [44.5 mm] from plug cap (24). See drawings shown in Figures 6.4.

WARNING: DO NOT start the pump until all rotating shafts and couplings are properly guarded.

4. Start the pump and close the discharge line valve slowly. **DO NOT** exceed the pressure rating of the pump or other equipment between the pump and the discharge line valve. If this pressure is reached while closing the discharge valve, **DO NOT** close any further.

NOTICE: DO NOT run the pump with a closed discharge line for more than one minute at a time.

5. With the discharge valve closed, turn adjusting screw clockwise in ½ turn increments until the pressure gauge shows the desired pressure setting.
6. Tighten the locknut (27).
7. Open the discharge line and turn off the pump.
8. Repeat steps 1-7 for the second relief valve, reversing the pumps rotation.

Both relief valves are now set to full bypass.

7. HIGH DRIVE TO LOW DRIVE

Prior to operating pump, make sure that the shaft rotation and pipe connections are in accordance with the appropriate illustration shown in Figure 6.1. In order to change the rotation and/or piping orientation, it may be necessary to remove the piping from the pump or the pump from the mounting.

Whenever changing rotation, inspect all parts before reassembly. Replace all worn parts and install new gaskets in appropriate numbers as removed. Refer to Section 12, **PARTS LIST & CROSS SECTIONALS**, Figures 12.1 & 12.2.

1. Remove coupling or universal joint and drive key (70) from drive gear/shaft assembly (72). Remove all burrs and sharp edges from drive shaft and keyway.
2. A.) To reverse pump rotation and keep piping arrangement the same, drive gear/shaft assembly (72) position must be changed. Follow steps 3 – 8.
B.) To reverse pump rotation and leave drive gear/shaft assembly (72) in same position; liquid flow through pump will be reversed. Follow step 9.
C.) To change port and drive shaft location, but keep the same rotation follow steps 10-13.

REVERSE ROTATION, SAME PIPING ARRANGEMENT

3. To reverse pump rotation and keep piping arrangement the same, it is necessary to change from high drive to low drive or low drive to high drive.
4. Remove twelve hex head cap screws (21 & 22) securing backplate assembly (20) to case (1) and separate backplate assembly from case. The drive gear/shaft assembly (72) will pull out with the backplate assembly.
5. Switch the idler gear/shaft assembly (73) positions in case (1).
6. Position appropriate number of case gaskets (5) on the case (1). Oil or grease may be used to hold gaskets in place.
7. Rotate backplate assembly (20) 180°.
8. Slide backplate assembly (20) with drive gear/shaft assembly (72) into position and secure.

REVERSE ROTATION, SAME DRIVE SHAFT AND CASE ARRANGEMENT

9. To reverse direction of flow through the pump, simply reverse direction of rotation of the drive gear/shaft assembly (72).

CHANGE PORT AND DRIVE SHAFT LOCATION, SAME ROTATION

10. To interchange the ports while maintaining the same pump rotation, change drive gear/shaft assembly (72) from high drive to low drive or vice versa.
11. Remove twelve hex head cap screws (21 & 22) securing backplate assembly (20) to case (1) and separate backplate assembly from case. The drive gear/shaft assembly (72) will pull out with backplate assembly.
12. Switch drive gear/shaft assembly (72) and idler gear/shaft assembly (73) positions in case (1).
13. Rotate backplate (20) assembly 180° and remount on case (1).

8. INSTRUCTIONS FOR DRAINING PUMP

Refer to Section 12, **PARTS LIST & CROSS SECTIONALS**, Figures 12.1 & 12.2

The extent to which a pump can be drained is dependent upon the product being pumped. Low viscosity products such as solvents will drain quickly and easily. High viscosity products such as molasses and tar will drain very slowly. Also, the draining of high viscosity products will be less complete.

Regardless of the product pumped, the areas at the blind end of the bearing bores and the mechanical seal chamber will not drain.

WARNING: Turn off the pump and lock out any energy source to driver. **DO NOT** proceed further with draining the pump if there is the slightest possibility that the driver may be started. Serious injury or death could occur.

1. Read and understand all safety instructions and warnings before starting draining procedure.
2. There are two pipe plugs (8A) in the backplate assembly (20). Remove the one that is in lowest position.
3. Rotate drive shaft very slowly by hand. Each time that flow from drain increases, stop turning shaft until flow stops; then resume until flow increases again. Be sure to rotate shaft several complete revolutions in each direction until all flow from drain has stopped.
4. Reinstall and tighten pipe plug (8A).

9. INSTRUCTIONS FOR PUMP DISASSEMBLY

Refer to Section 12, **PARTS LIST & CROSS SECTIONALS**, Figures 12.1 & 12.2

1. Read and understand all safety instructions and warnings before starting to disassemble pump. While disassembling pump, always inspect disassembled parts and adjacent parts to see if further disassembly is needed. Replace worn or damaged parts as required.
2. If you do not know which pump arrangement you have, collect nameplate data and refer to Section 1, **NAMEPLATE DATA**, to determine what you have. Consult a Roper distributor or Roper Pump Company if you have any questions.
3. When cleaning or lubricating, use only cleaning solutions and lubricants that are compatible with products being pumped and with sealing elastomers. **DO NOT** use petroleum base products on seals made from EPR elastomers. Use a nonpetroleum base lubricant with EPR elastomers.
4. Turn off pump and lock out energy source to driver. **DO NOT** proceed further with disassembly of pump if there is the slightest possibility that driver may be started.
5. Close inlet and discharge valves.
6. Remove guard and disconnect coupling between driver and pump.
7. Drain inlet and discharge lines. Disconnect lines from pump inlet and discharge.
8. Follow the procedure in Section 8, **INSTRUCTIONS FOR DRAINING PUMP**.

9. Plain Faceplate

- a. Remove twelve hex head cap screws (21 & 22) securing the faceplate assembly (45A) to case (1).
- b. By screwing two long 3/8 – 16 thread bolts in jack holes, remove the faceplate assembly (45A).

BV Relief Valve Faceplate

- a. Remove ten hex head cap screws (19) securing the bi-directional relief valve faceplate (45B) to spacer assembly (44). See Section 6, **ROTATIONS & RELIEF VALVES** for bi-directional relief valve faceplate disassembly.
- b. Remove relief valve assembly gasket (5B).
- c. Remove ten hex head cap screws (17) and two socket cap screws (18) securing spacer assembly (44) to case (1).
- d. Remove spacer assembly (44).

10. Remove case gaskets (5).
11. Remove idler gear/shaft assembly (73).
12. H Head Backplate

- a. Remove packing nut (87A) from end of backplate (20).
- b. Remove drive gear/shaft assembly (72)..

BH Head Backplate

Shaft Sealing: Packing Rings

- a. Remove two locknuts (85), gland clips (86), square head cap screws (89) and one spring clip (90).
- b. Remove two-piece split packing gland (87B).
- c. Remove packing rings (91) and one packing washer (92).
- d. Remove drive gear/shaft assembly (72).

Shaft Sealing: Triple Lip Seal

- a. Remove two locknuts (85), square head cap screws (89A) and seal retainer (93).
 - b. Remove drive gear/shaft assembly (72).
 - c. Remove packing washer (93) and triple lip seal (65).
13. Remove twelve hex head cap screws (21 & 22) securing the backplate assembly (20) to case (1).
 14. By screwing two long 3/8 – 16 thread bolts in jack holes, remove the backplate assembly (20).
 15. Remove case gaskets (5) from case (1).
 16. Remove four dowel pins (4) from case (1).
 17. Visually inspect all parts. Replace all worn or damaged parts before reassembling pump. It is recommended that new gaskets and packing rings be installed each time pump is disassembled and reassembled.

10. BEARING REMOVAL AND INSTALLATION

BEARING REMOVAL

1. Remove NPT plugs (8B) from ends of bearing areas in the plain faceplate assembly (45A) and backplate assembly (20).
2. Place backplate assembly (20), plain faceplate assembly (45A) or spacer assembly (44) face down on press.
3. Using proper size arbor, press bearings out.

BEARING INSTALLATION

1. Remove all burrs and raised edges from bores for bearings.
2. Place backplate, plain faceplate or spacer assembly on a press base with machined face upward. Support endplate so that milled face is perpendicular (square) with press ram.
3. Position endplate so that one bearing bore is located directly under press ram.
4. Lubricate endplate bores with light oil that is compatible with product to be pumped.
5. Place end of new bearing at entrance of bore in endplate.
6. Press bearing into endplate bore. It is best to use a stepped arbor with a few thousandths of an inch clearance between arbor and bore of bearing. Be sure to press bearings in until they are flush to .005 of an inch [.127 mm] below milled face of endplate.
7. Repeat procedure for second bearing.

11. INSTRUCTIONS FOR PUMP ASSEMBLY

Refer to Section 12, **PARTS LIST & CROSS SECTIONALS**, Figures 12.1 & 12.2

Refer to Section 6, **DIRECTION OF ROTATION & RELIEF VALVES**, to assure proper configuration for pump rotation and port location prior to assembling pump.

1. Read and understand all safety instructions and warnings before assembling pump. Visually inspect all parts during assembly. Replace all worn or damaged parts. Although they may appear reusable, it is recommended that new gaskets (2, 5 & 5B) and packing rings (91) be installed when pump is being reassembled.

NOTICE: Only use genuine Roper gaskets. Gasket thickness determines proper pump lateral running clearances. Always check quantity of gaskets removed and replace with the same quantity. Proper gasket material must be used for the anticipated application.

2. When cleaning or lubricating, only use products that are compatible with product being pumped and elastomers within pump. **DO NOT** use petroleum base products on seals made from EPR elastomers. Clean and lubricate parts with light oil unless EPR elastomers are used. Use a nonpetroleum base lubricant with EPR elastomers.
3. Plain Faceplate
 - a. Drive in two dowel pins (4) into the case (1)
 - b. Place the appropriate number of case gaskets (5) on the faceplate side of the case (1).
 - c. Align plain faceplate assembly (45A) on the case (1) and dowel pins (4). Install and finger tighten two hex head cap screws (21) at top and bottom of faceplate assembly (45A).
 - d. Secure plain faceplate assembly (45A) to the case (1) with ten hex head cap screws (20). Tighten all twelve hex head cap screws.

BV Relief Valve Faceplate

- a. Drive in two dowel pins (4) into the case (1).
 - b. Place the appropriate number of case gaskets (5) on the spacer assembly side of the case (1).
 - c. Align spacer assembly (44) on the case (1) and dowel pins (4). Install and finger tighten two hex head cap screws (22) at top and bottom of the spacer assembly (44).
 - d. Secure spacer assembly (44) to the case (1) with eight hex head cap screws (22) and two socket head cap screws (18). Tighten all ten hex head and two socket head cap screws.
 - e. Secure one gasket (5B) and bi-directional relief valve faceplate assembly (45B) to the spacer assembly (44) with ten hex head cap screws (19). See Section 6, **ROTATIONS & RELIEF VALVES** for bi-directional relief valve faceplate assembly.
4. Place drive gear/shaft assembly (72) and idler gear/shaft assembly (73) into case bores.

5. H Head Backplate

- a. Drive in two dowels (4) into the case (1).
- b. Place appropriate number of case gaskets (5) on backplate assembly (20) side of case (1). Slide backplate over shafts and up to case. Secure backplate assembly (20) to case (1) with twelve hex head cap screws (20 & 21) and tighten.
- c. Install three packing rings (91) in packing nut (87A) bore. Stagger joints on each packing ring 180° apart. Rings must not be tamped or seated.
- d. Slide packing nut (87A) with rings over end of drive shaft.
- e. Screw packing nut (87A) on backplate assembly (20) finger tight. Tighten nut ½ to ¾ of a turn, then loosen to finger tight. See Section 13, **SHAFT SEALING** for instructions on tightening packing rings.

- f. Attach lockwire (9) to packing nut (87A) and lube fitting (25). Be sure to wrap lockwire in a clockwise direction facing drive shaft end.

BH Head Backplate

- a. Drive in two dowels (4) into the case (1).
- b. Place appropriate number of case gaskets (5) on backplate assembly (20) side of case (1). Slide backplate over shafts and up to case. Secure the backplate assembly to the case (1) with twelve hex head cap screws (21 & 22) and tighten.

Shaft Sealing: Packing Rings

- a. Install packing washer (92) first and then packing rings (91) into the backplate assembly (20) bore. Stagger joints on each packing ring 180° apart. Rings must not be tamped or seated.
- b. Install split packing gland (87B).
- c. Secure split packing gland (87B) with two locknuts (85), gland clips (86), square head cap screws (89) and one spring clip (90). See Section 13, **SHAFT SEALING** for instructions on tightening packing rings.

Shaft Sealing: Triple Lip Seal

Note: Lubricate the drive shaft with an appropriate fluid compatible with the product being pumped. The triple lip seal fits tight on the shaft. Take care when installing. Deburr or file any sharp edges that could cause damage to the seal (e.g. edges of the keyway).

- a. Install triple lip seal (65) into the backplate assembly (20) bore. Install packing washer (92) into the backplate assembly (20). Press both the triple lip seal and packing washer into the backplate bore flush with the edge of the bore.
- b. Install the seal retainer (93). Secure the seal retainer (93) with two square head cap screws (89A) and two locknuts (85) to the backplate assembly (20).

12. PARTS LIST & CROSS SECTIONALS

5658HF-1

Item No.	Description	Qty.
1	Case	1
2	Flange Gasket	2
3	Flange	2
4	Dowel Pin	4
5	Case Gasket	11
6	Hex Head Cap Screw	8
8A	Pipe Plug (Small)	4
8B	Pipe Plug (Large)	3
9	Lockwire	1
20	Backplate Assembly	1
21	Hex Head Cap Screw	4
22	Hex Head Cap Screw	10
25	Lube Fitting	4
45	Plain Faceplate Assembly	1
70	Drive Key	1
72	Drive Gear/Shaft Assembly	1
73	Idler Gear/Shaft Assembly	1
87	Packing Nut	1

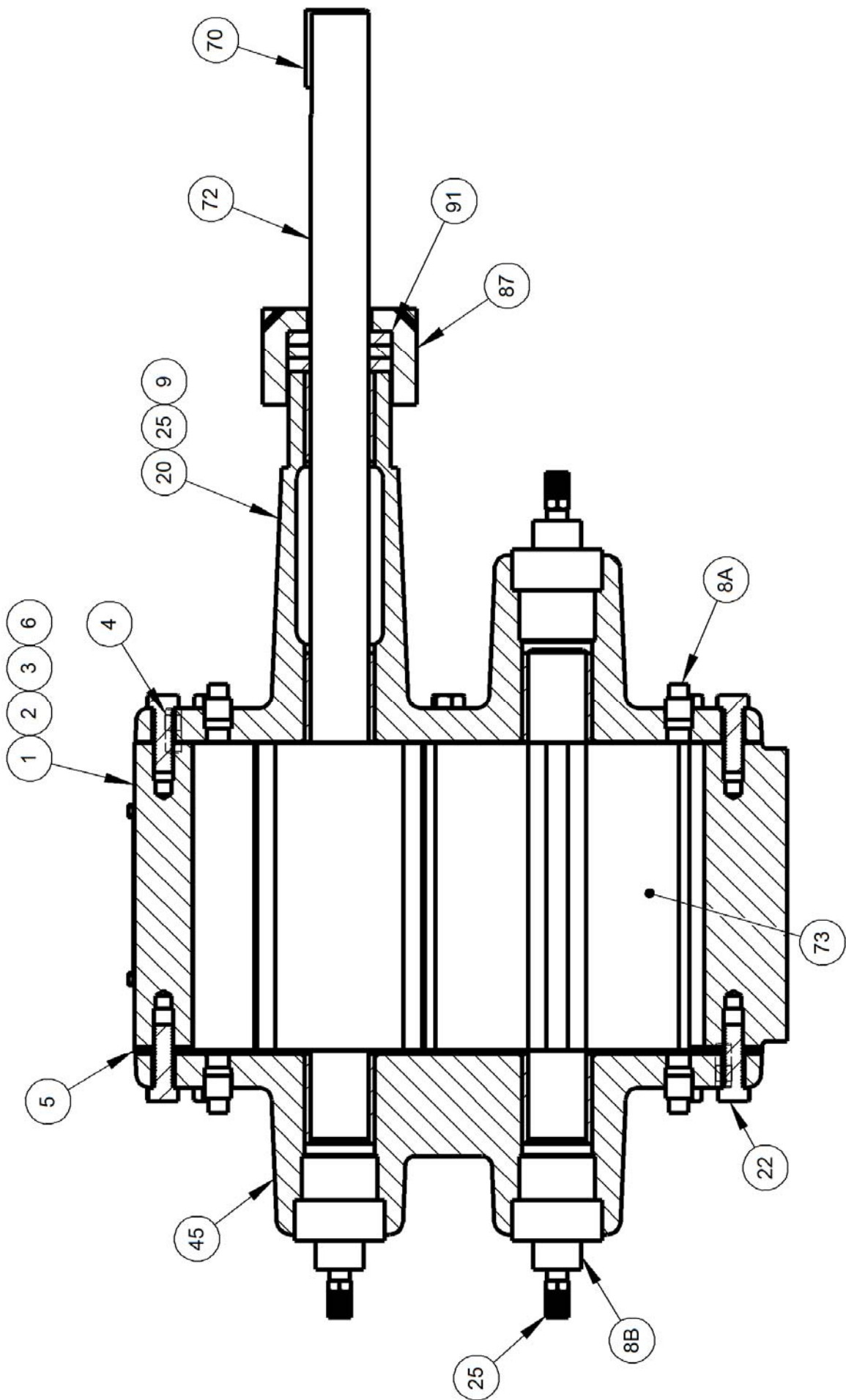

Figure 12.1, 5658HF-1

5x58BHFBV-1

Item No.	Description	Qty.
1	Case	1
2	Flange Gasket	2
3	Flange	2
4	Dowel Pin	4
5	Case Gasket	11
5A	Hex Head Cap Screw	8
8A	Pipe Plug (Small)	4
8B	Pipe Plug (Large)	3
9	Lockwire	1
17	Hex Head Cap Screw	10
18	Socket Head Cap Screw	2
19	Hex Head Cap Screw	10
20	Backplate Assembly	1
21	Hex Head Cap Screw	2
22	Hex Head Cap Screw	10
24	BV Relief Valve Cap	2
25	Lube Fitting	4
26	Adjusting Screw	2
27	Locking Seal Nut	2
28	Spring Guide	2
29	Spring	2
30	Poppet	2
31	Spring Washer	2
44	Spacer Assembly	1
45B	BV RV Faceplate Assembly	1
65	Triple Lip Seal	
70	Drive Key	1
72	Drive Gear/Shaft Assembly	1
73	Idler Gear/Shaft Assembly	1
85	Locknut	2
86	Packing Gland Clip	2
87B	Packing Gland	1
89	Square Head Cap Screw	2
89A	Square Head Cap Screw	2
90	Spring Clip	1
91	Packing Rings	6
92	Packing Washer	1
93	Seal Retainer	1

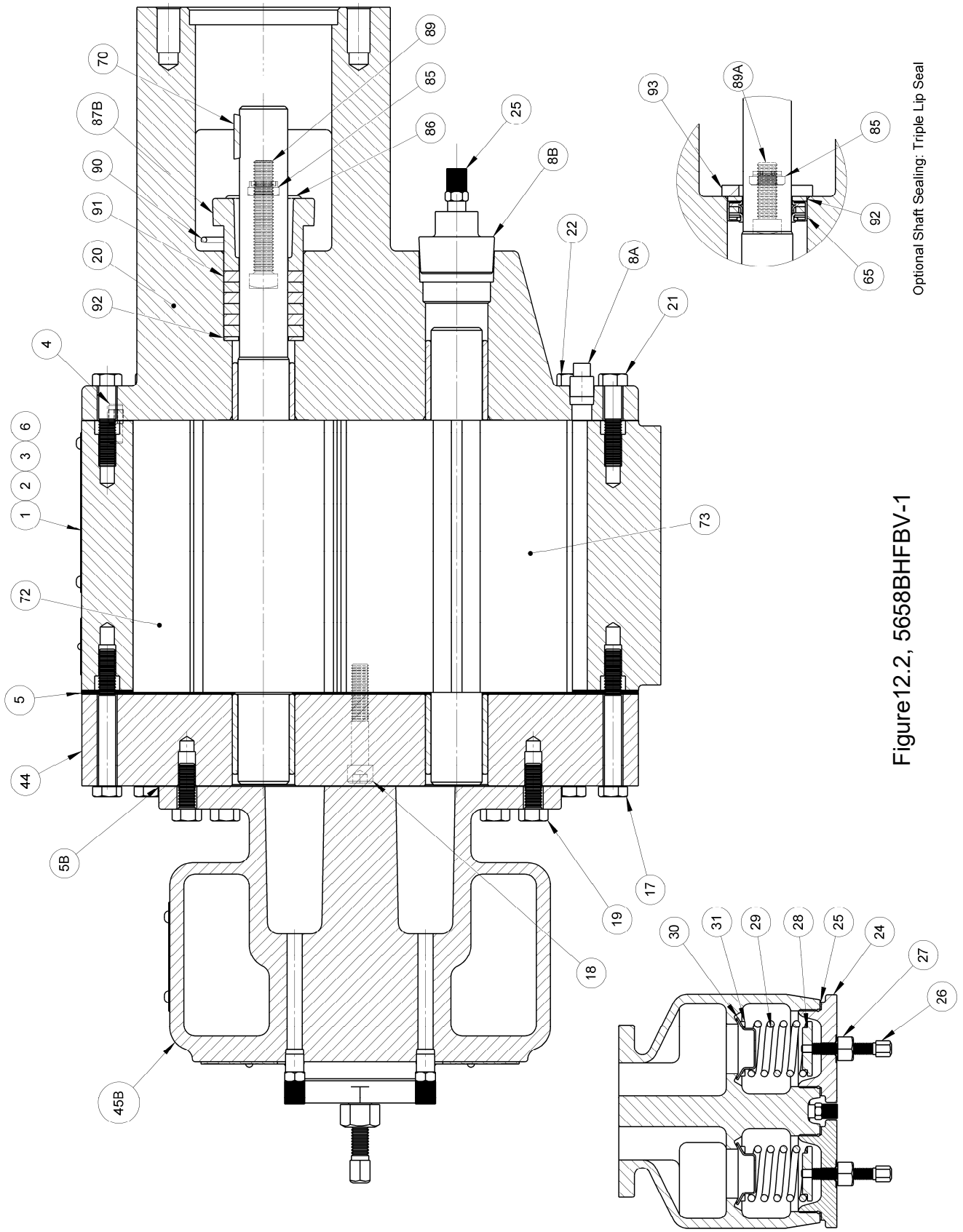

Figure 12.2, 5658BHFBV-1

Optional Shaft Sealing: Triple Lip Seal

13. SHAFT SEALING

STANDARD COMPRESSION PACKING

The type of shaft sealing used in these pumps is formed ring packing with or without a lantern ring. When using a packed box pump, use formed packing rings. **DO NOT** use a one piece spiral wrap of packing. Packing rings are available in a wide selection of materials for various applications and temperatures. Previous experience with the pumped fluid is the best guide in selecting the proper packing ring material for your particular application.

CARE OF PACKING

Packing hooks are commercially available to help in removing packing rings from the stuffing box. It is generally not recommended to reuse old packing rings. When installing packing, use formed packing rings.

DO NOT use a one piece spiral wrap of packing. Before installing packing, carefully clean the stuffing box and shaft.

Packing rings should be installed one ring at a time, with the joints of adjacent rings staggered approximately 180°. Each ring should be seated firmly before the next ring is installed.

The packing gland nut should be tightened with a wrench to seat the packing firmly in the stuffing box and against the shaft. **DO NOT** over-tighten the packing. The gland nut should then be backed off until finger-tight. Connect the lockwire from the packing nut to the pipe plug (grease fitting) adjacent to the packing nut and twist ends together.

NOTEICE: The wire should be wrapped in a clockwise direction from the packing nut to the hex head cap screw.

After the pump is started, note the amount of leakage from the stuffing box. If the packing leakage exceeds ten drops per minute, stop the pump and adjust the gland nut. The gland nut should be adjusted evenly in 1/6 to 1/3 turn (1 to 2 flats on the nut) increments. Start the pump and allow it to operate for several minutes. Again, visually examine the stuffing box for excessive leakage. Repeat the above procedure until the stuffing box leakage is between five to ten drops per minute.

DO NOT over-tighten the packing. Slight leakage is a necessary requirement for proper packing operation. Leakage of five to ten drops per minute when the pump is operating is desirable, as it will preserve the packing and avoid scoring of the shaft. Over-tight packing may score shafts, increase torque requirements of the pump, damage couplings and drivers, and generate excessive heat.

The pump should be stopped and the packing gland adjusted whenever leakage exceeds ten drops per minute. The condition of the packing should be checked at regular intervals, the frequency depending on the type of service. Experience will dictate how frequently the inspections should be made.

TRIPLE LIP SEAL

A triple lip seal can be used in the same backplates used for shaft packing. The triple lip seal comes from the manufacturer with a small amount of grease between the lips. Do not remove this grease as it is necessary to provide lubrication to the inner lips on startup. **DO NOT** distort the metal casing around the triple lip seal when installing the seal. Be very careful not to damage or distort the seal lips during installation. The standard triple lip seal arrangement is good for products that will not solidify when exposed to air. Optional arrangements are available where a barrier fluid or flush is required to prevent exposure of the triple lip seal to air.

14. LUBRICATION

Pumps are fitted with lube fittings to all four bearings. Lubricate the bearing on a regular basis with any good quality bearing grease that is compatible with the product being pumped.

NOTICE: Pumps equipped with the bi-directional relief valve faceplate will need a larger quantity of grease, due to the larger cavities in the faceplate. See cross sectional in Section 12, **PARTS LIST & CROSS SECTIONALS**, Figure 12.2

15. INDEX

Assembly Instructions, 10, 15-16

Bearing

Removal, and Installation, 14

Conversions

High Drive to Low Drive, 11-12

Disassembly Instructions, 10, 13-14

Draining Pump, 12

Guarding Power Take-Off Shafts, 4

Lubrication, 20

Mounting Base, 4

Nameplate Data, 5-6

Packing Standard Compression, 21

Parts List and Drawing, 17-20

Preoperational Checks, 7

Plumbing, 3

Ratings, 7

Relief Valve, 8-11

Rotation, 8, 11-12

Shaft Sealing, 21

Special Precautions for PTO Drive, 4

Special Warnings, 3-4

Tools, 7