

BARNES®

INSTALLATION MANUAL Submersible Effluent, Sump & Sewage Ejectors

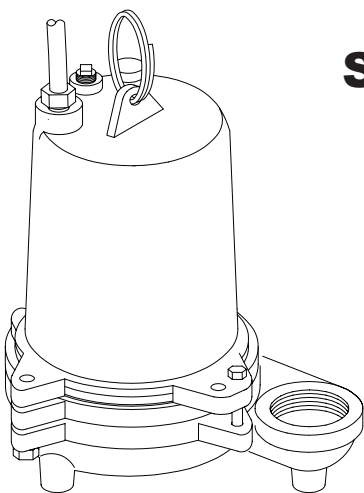

Series: * **BP314 & BP324, .3hp**
* **SE411 & SE421, .4hp**
SE511 & SE521, .5hp
SEV511 & SEV521, .5hp
1750 RPM, 60 Hz.
***(Standard & High Temperature)**

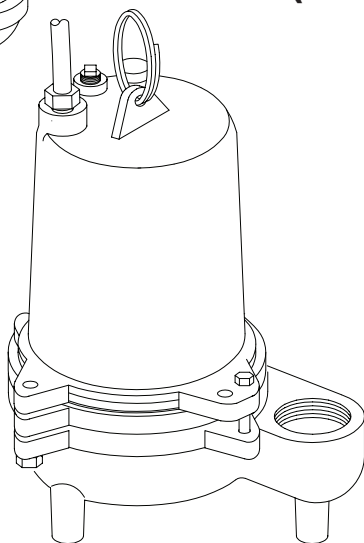

IMPORTANT!

*Read all instructions in this manual before operating pump.
As a result of Crane Pumps & Systems, Inc., constant product improvement program,
product changes may occur. As such Crane Pumps & Systems reserves the right to
change product without prior written notification.*

CRANE[®]

A Crane Co. Company

PUMPS & SYSTEMS

420 Third Street
Piqua, Ohio 45356
Phone: (937) 778-8947
Fax: (937) 773-7157
www.cranepumps.com

83 West Drive, Bramton
Ontario, Canada L6T 2J6
Phone: (905) 457-6223
Fax: (905) 457-2650



Form No. 098846-Rev.AJ

TABLE OF CONTENTS

WARNINGS AND SAFETY PRECAUTIONS	3
A. PUMP SPECIFICATIONS	4
PUMP DIMENSIONS	5 - 6
B. GENERAL INFORMATION (Receiving, Storage, Service Centers).....	7
C. INSTALLATION INSTRUCTIONS (Location, Submergence, Discharge) (Fig. 1)	7
(Level Controls, Power Cable) (Fig. 2 & 3)	7 - 8
(Overload Protection, Wire Size).....	8
(Electrical Data).....	9
D. START-UP OPERATION (Check, Voltage, Phase & Rotation, Start-Up Report, Insulation & Pump-Down test).	10
E. PREVENTATIVE MAINTENANCE	10
F. SERVICE AND REPAIR (Lubrication, Checking Oil, Testing Oil, Replacing Oil)	10
(Pressure test, Impeller & Volute, Motor, Bearing & Cable Service) (Fig. 4, 5, 6, 7, 8, 9, 10).....	11 - 14
(Shaft Seal Service) (Fig. 11, 12, 13).....	14 - 15
G. REPLACEMENT PARTS.....	15
TROUBLE SHOOTING.....	16
BP SERIES - CROSS-SECTION (Fig. 14).....	17
BP SERIES - EXPLODED VIEW (Fig. 15).....	18
BP SERIES - PARTS LIST	19 - 21
SE SERIES - CROSS-SECTION (Fig. 16).....	22
SE SERIES - EXPLODED VIEW (Fig. 17).....	23
SEV SERIES - CROSS-SECTION (Fig. 18)	24
SEV SERIES - EXPLODED VIEW (Fig. 19)	25
SE & SEV SERIES - PARTS LIST	26 - 28
PERFORMANCE CURVE - BP314, BP324, BP314HT, BP324HT Series.....	29
PERFORMANCE CURVE - SE511, SE521, SEV511, SEV521 Series.....	29
PERFORMANCE CURVE - SE411 & SE421.....	30
PERFORMANCE CURVE - SE411HT & SE421HT	30
RETURN GOODS POLICY.....	32
WARRANTY	
START UP REPORT	
WARRANTY REGISTRATION	
SPECIAL TOOLS and EQUIPMENT:	
INSULATION TESTER (MEGGER)	
DIELECTRIC TESTER	
SEAL TOOL KIT (see parts list)	
PRESSURE GAUGE KIT (see parts list)	

Other brand and product names are trademarks or registered trademarks of their respective holders.

® Barnes is a registered trademark of Crane Pumps & Systems, Inc.

1997, 2002, 01/04, 9/05, 2/06, 9/06

Alteration Rights Reserved

SAFETY FIRST!

Please Read This Before Installing Or Operating Pump. This information is provided for **SAFETY** and to **PREVENT EQUIPMENT PROBLEMS**. To help recognize this information, observe the following symbols:



IMPORTANT! Warns about hazards that can result in personal injury or indicates factors concerned with assembly, installation, operation, or maintenance which could result in damage to the machine or equipment if ignored.

CAUTION! Warns about hazards that can or will cause minor personal injury or property damage if ignored. Used with symbols below.

WARNING! Warns about hazards that can or will cause serious personal injury, death, or major property damage if ignored. Used with symbols below.



Hazardous fluids can cause fire or explosions, burns or death could result.



Extremely hot - Severe burns can occur on contact.



Biohazard can cause serious personal injury.



Hazardous fluids can Hazardous pressure, eruptions or explosions could cause personal injury or property damage.



Rotating machinery Amputation or severe laceration can result.



Hazardous voltage can shock, burn or cause death.

Only qualified personnel should install, operate and repair pump. Any wiring of pumps should be performed by a qualified electrician.



WARNING! To reduce risk of electrical shock, pumps and control panels must be properly grounded in accordance with the National Electric Code (NEC) or the Canadian Electrical Code (CEC) and all applicable state, province, local codes and ordinances. Improper grounding voids warranty.



WARNING! To reduce risk of electrical shock, always disconnect the pump from the power source before handling or servicing. Lock out power and tag.



WARNING! Operation against a closed discharge valve will cause premature bearing and seal failure on any pump, and on end suction and self priming pump the heat build

may cause the generation of steam with resulting dangerous pressures. It is recommended that a high case temperature switch or pressure relief valve be installed on the pump body.



CAUTION! Never operate a pump with a plug-in type power cord without a ground fault circuit interrupter.



CAUTION! Pumps build up heat and pressure during operation-allow time for pumps to cool before handling or servicing.



WARNING! Do not pump hazardous materials (flammable, caustic, etc.) unless the pump is specifically designed and designated to handle them.



CAUTION! Do not block or restrict discharge hose, as discharge hose may whip under pressure.



WARNING! Do not wear loose clothing that may become entangled in moving parts.



WARNING! Keep clear of suction and discharge openings. **DO NOT** insert fingers in pump with power connected.

Always wear eye protection when working on pumps.



Make sure lifting handles are securely fastened each time before lifting. **DO NOT** operate pump without safety devices in place. Always replace safety devices that have been removed during service or repair. Secure the pump in its operating position so it can not tip over, fall or slide.



DO NOT exceed manufacturers recommendation for maximum performance, as this could cause the motor to overheat.

DO NOT remove cord and strain relief. **DO NOT** connect conduit to pump.



WARNING! Cable should be protected at all times to avoid punctures, cut, bruises and abrasions. Inspect frequently. Never handle connected power cords with wet hands.



WARNING! To reduce risk of electrical shock, all wiring and junction connections should be made per the NEC or CEC and applicable state or province and local codes. Requirements may vary depending on usage and location.



WARNING! Submersible Pumps are not approved for use in swimming pools, recreational water installations decorative fountains or any installation where human contact with the pumped fluid is common.



WARNING! Products returned must be cleaned, sanitized, or decontaminated as necessary prior to shipment, to insure that employees will not be exposed to health hazards in handling said material. All Applicable Laws And Regulations Shall Apply.



Bronze/brass and bronze/brass fitted pumps may contain lead levels higher than considered safe for potable water systems. Lead is known to cause cancer and birth defects or other reproductive harm. Various government agencies have determined that leaded copper alloys should not be used in potable water applications. For non-leaded copper alloy materials of construction, please contact factory.



Crane Pumps & Systems, Inc. is not responsible for losses, injury, or death resulting from a failure to observe these safety precautions, misuse or abuse of pumps or equipment.

PUMP SPECIFICATIONS SERIES:

STANDARD SERIES:

DISCHARGE 2" NPT, Female, Vertical
LIQUID TEMPERATURE:
 115 Volt..... 77°F (25°C) Continuous
 230 Volt..... 104°F (40°C) Continuous
MOTOR HOUSING Cast Iron ASTM A-48, Class 30
VOLUTE Cast Iron ASTM A-48, Class 30
 (BP-BR) Bronze 81-3-7-9
SEAL PLATE Cast Iron ASTM A-48, Class 30
 (BP-BR) Bronze 81-3-7-9
IMPELLER: Design 2-vane, Open with Pump Out Vanes on
 Back Side. Dynamically Balanced,
 ISO G6.3

BP314 & BP324 Series:
Material Polypropylene with Stainless Insert
 BP314BR & BP324BR Series:
Material Bronze 81-3-7-9
 SE411 & SE421 Series:
Material Cast Iron ASTM A-48, Class 30
 SE511 & SE521 Series:
Material Cast Iron ASTM A-48, Class 30

IMPELLER - SEV511 & SEV521
Design 12-vane, Open with Pump Out Vanes on
 Back Side. Dynamically Balanced,
 ISO G6.3
Material Cast Iron ASTM, A-48, Class 30

SHAFT..... 416 Stainless Steel
O-RINGS Buna-N
HARDWARE 300 Series Stainless Steel
PAINT Air dry enamel
SEAL *Design*..... Single Mechanical, Oil Filled reservoir
 Secondary Exclusion Seal
Material Carbon/Ceramic/Buna-N
 Hardware - 300 series stainless steel

CORD ENTRY 15 Ft. (5m) Quick disconnect cord
 with plug on 115 volt, pressure
 grommet for sealing and strain relief.

UPPER BEARING:
Design..... Single Row, Ball, Oil Lubricated
Load..... Radial

LOWER BEARING:
Design..... Single Row, Ball, Oil Lubricated
Load..... Radial & Thrust

MOTOR: Design..... NEMA L Torque Curve. Oil Filled
 Squirrel Cage Induction
Insulation Class B

SINGLE PHASE..... Permanent Split Capacitor (PSC)
 Includes Thermal Overload
 Protection in motor

LEVEL CONTROLS:
 A..... Wide Angle, PVC, Mechanical,
 15 Ft. (5m) Cord w/Piggy-back plug
 N/O, Pipe Mounted
 AU..... Wide Angle, Polypropylene,
 Mechanical, N/O, Integral to pump.
 ON and OFF Points are Adjustable
 VF Vertical Float, PVC, Snap Action,
 15 Ft. (5m) Cord w/Piggy-back plug
 OFF Point only is Adjustable.

OPTIONAL EQUIPMENT.... Seal Material, Additional Cord,
 and Cast Iron Impeller

HIGH TEMPERATURE SERIES:

DISCHARGE 2" NPT, Female, Vertical
LIQUID TEMPERATURE 200°F (93°C) Continuous
VOLUTE Cast Iron ASTM A-48, Class 30
MOTOR HOUSING Cast Iron ASTM A-48, Class 30
SEAL PLATE Cast Iron ASTM A-48, Class 30
IMPELLER: Design 2 Vane, Open with pump out
 vanes on back side. Dynamically
 Balanced, ISO G6.3

BP314HT & BP324HT Series:
Material Bronze 81-3-7-9
 SE411HT & SE421HT Series:
Material Cast Iron ASTM A-48, Class 30

SHAFT 416 Stainless Steel
SQUARE RINGS Buna-N
HARDWARE 300 Series Stainless Steel
PAINT Air Dry Enamel
SEAL: Design Single Mechanical, Oil Filled
 Reservoir, Secondary Exclusion
 Seal
Material Carbon/Ceramic/Buna-N
 Hardware -300 Series Stainless

CORD ENTRY 15 ft. (5m) Cord with plug On 115
 volt, Pressure Grommet for
 sealing and strain relief

UPPER BEARING..... Single Row, Ball, Oil Lubricated
LOWER BEARING..... Single Row, Ball, Oil Lubricated
MOTOR: Design NEMA L Torque Curve, Oil Filled,
 Squirrel Cage Induction
Insulation Class B

SINGLE PHASE..... Permanent Split Capacitor (PSC)
 Includes Overload Protection in
 Motor

LEVEL CONTROL
 A..... Wide Angle, PVC, Mechanical,
 15 ft (5m) cord with Piggy-Back
 Plug, N/O
 AU Wide Angle, Polypropylene,
 Mechanical, N/O Integral to pump.
 ON and OFF Points are adjustable

OPTIONAL EQUIPMENT Seal Material, Additional Cord,
 Strainer

SERIES: BP314 & BP324

inches
(mm)

BP314VF, BP314VFB

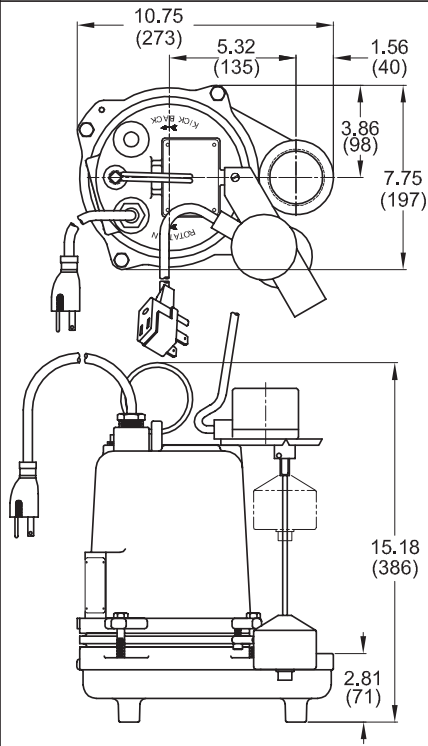

BP314A, BP314ABR
BP314, BP314BR, BP324, BP324BR (Less Float)

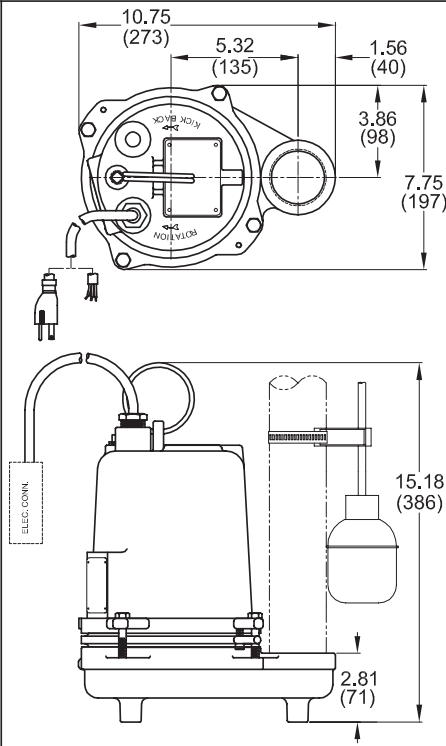

BP314AU, BP314AUBR
BP324AU, BP324AUBR

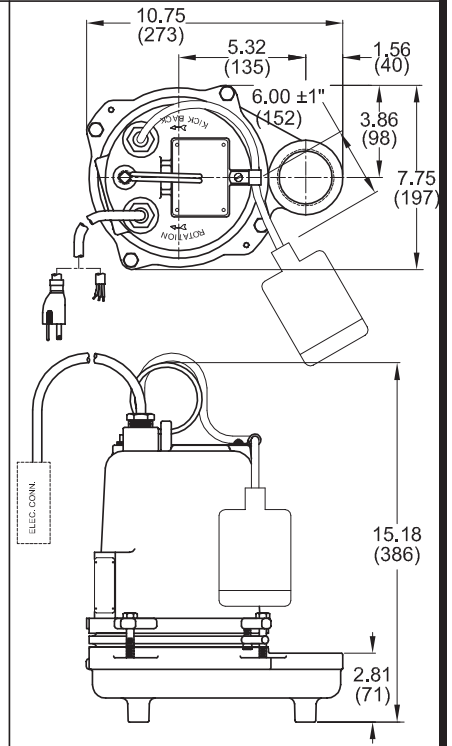

BP314HT, BP314HTBR
BP324HT, BP324HTBR

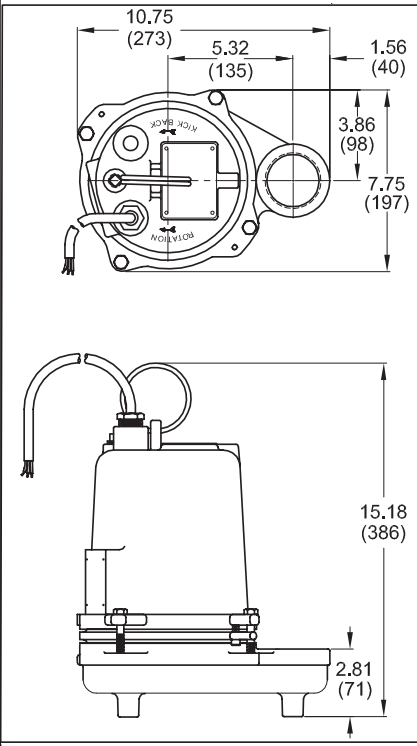

BP314HTA, BP314HTABR

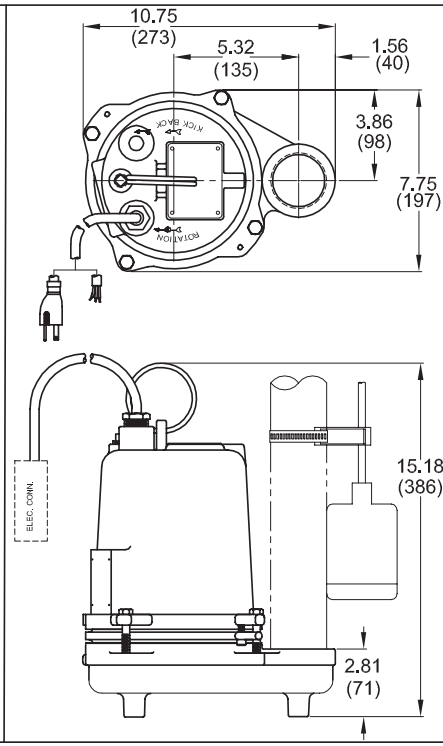

BP314HTAU, BP314HTAUBR
BP324HTAU, BP324HTAUBR

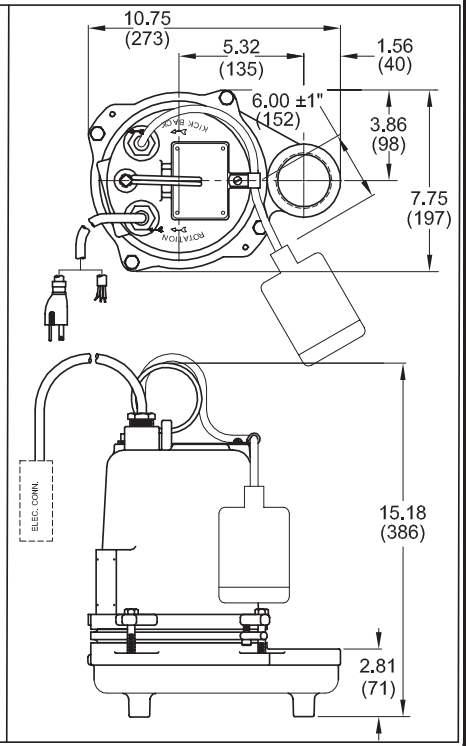

SERIES: SE411, SE421, SE511, SE521, SEV511 & SEV521

inches
(mm)

**SE411VF
SE511VF, SEV511VF**

**SE411, SE421, SE511, SE521 (Less Float)
SEV511, SEV521 (Less Float)
SE411A, SE511A, SEV511A**

**SE511AU, SE521AU, SEV511AU,
SEV521AU**

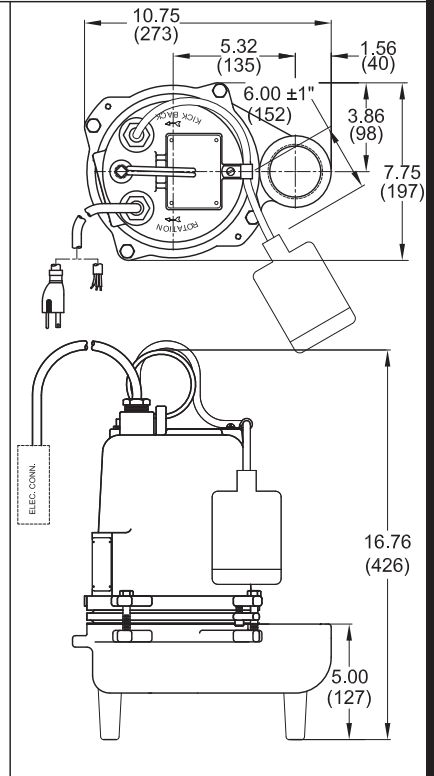
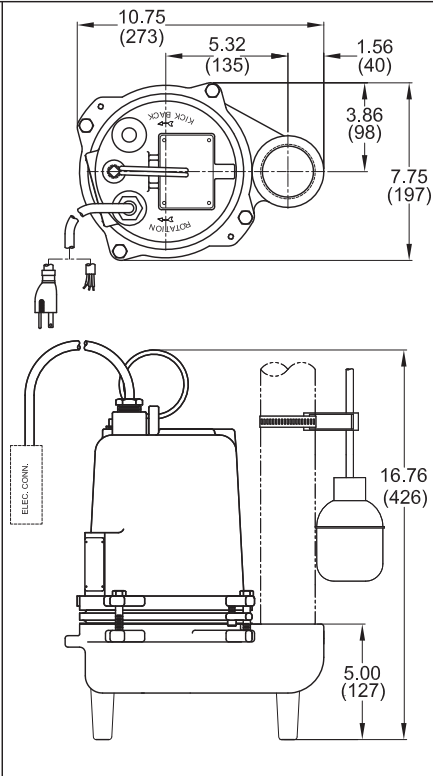
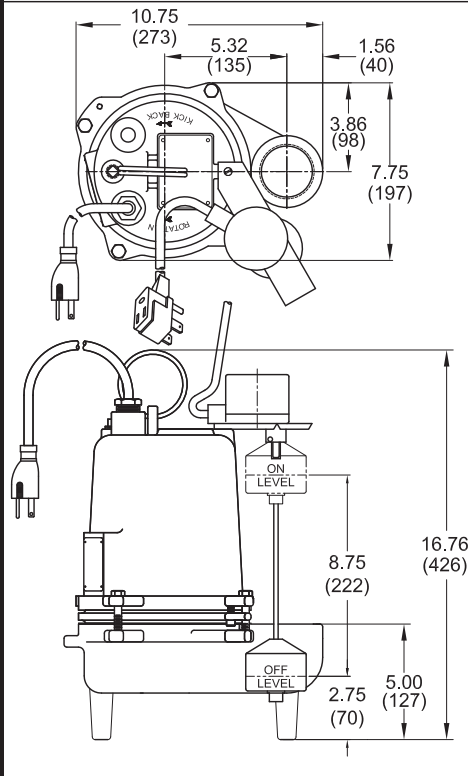

SE411HT, SE421HT

SE411HTA

SE411HTAU, SE421HTAU

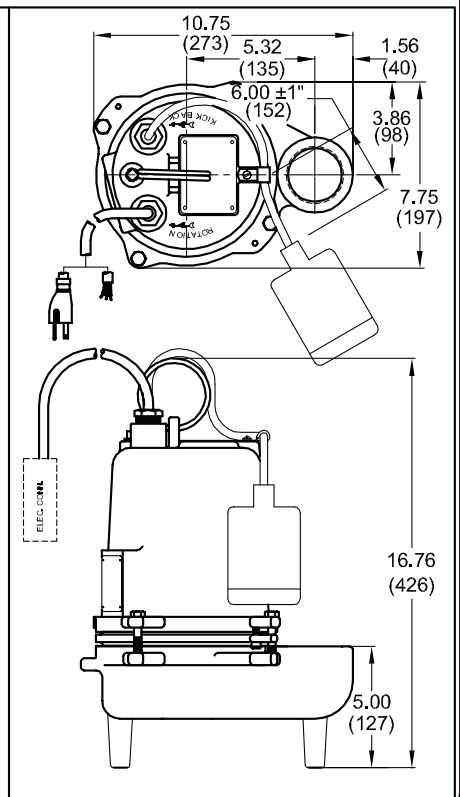
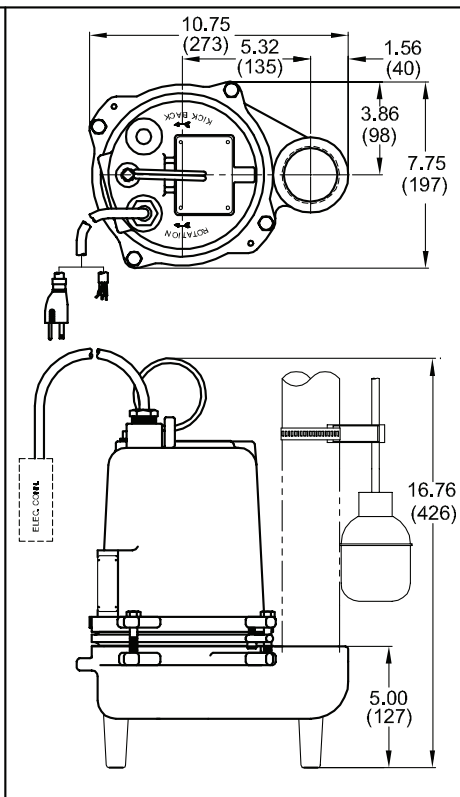
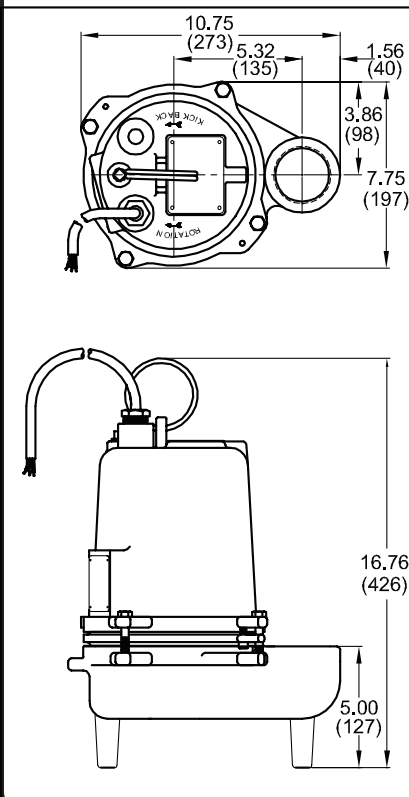

SECTION B: GENERAL INFORMATION

B-1) To The Purchaser:

Congratulations! You are the owner of one of the finest pumps on the market today. Barnes® Pumps are products engineered and manufactured of high quality components. Over one hundred years of pump building experience along with a continuing quality assurance program combine to produce a pump which will stand up to the toughest applications.

Check local codes and requirements before installation. Servicing should be performed by knowledgeable pump service contractors or authorized service stations.

The pump is packaged ready for installation and no connections or adjustments are necessary except for attaching discharge piping and plugging in service cord.

B-2) Receiving:

Upon receiving the pump, it should be inspected for damage or shortages. If damage has occurred, file a claim immediately with the company that delivered the pump. If the manual is removed from the crating, do not lose or misplace.

B-3) Storage:

Short Term- Barnes Pumps are manufactured for efficient performance following long inoperative periods in storage. For best results, pumps can be retained in storage, as factory assembled, in a dry atmosphere with constant temperatures for up to six (6) months.

Long Term- Any length of time exceeding six (6) months, but not more than twenty four (24) months. The units should be stored in a temperature controlled area, a roofed over walled enclosure that provides protection from the elements (rain, snow, wind blown dust, etc.), and whose temperature can be maintained between +40 deg. F and +120 deg. F. Pump should be stored in its original shipping container and before initial start up, rotate impeller by hand to assure seal and impeller rotate freely.

B-4) Service Centers:

For the location of the nearest Barnes Service Center, check your Barnes representative or Crane Pumps & Systems, Inc., Service Department in Piqua, Ohio, telephone (937) 778-8947 or Crane Pumps & Systems Canada, Inc., Bramton, Ontario, (905) 457-6223.

SECTION C: INSTALLATION

C-1) Location:

These pumping units are self-contained and are recommended for use in a sump or basin. The sump or basin shall be vented in accordance with local plumbing codes. This pump is designed to pump effluent or wastewater, nonexplosive and noncorrosive liquids and shall NOT be installed in locations classified as hazardous in accordance with the National Electrical Code (NEC),

ANSI/NFPA 70 or Canadian Electric Code (CEC). Never install the pump in a trench, ditch, or hole with a dirt bottom; the legs will sink into the dirt and the suction will become plugged.

C-1.1) Submergence:

The pump should always be operated in the submerged condition. The minimum sump liquid level should never be less than A Dimension, A = 3 inches on BP Series and A = 6 inches on SE Series above the pump bottom. The recommended level should not drop below the top of the motor housing (see Fig. 1).

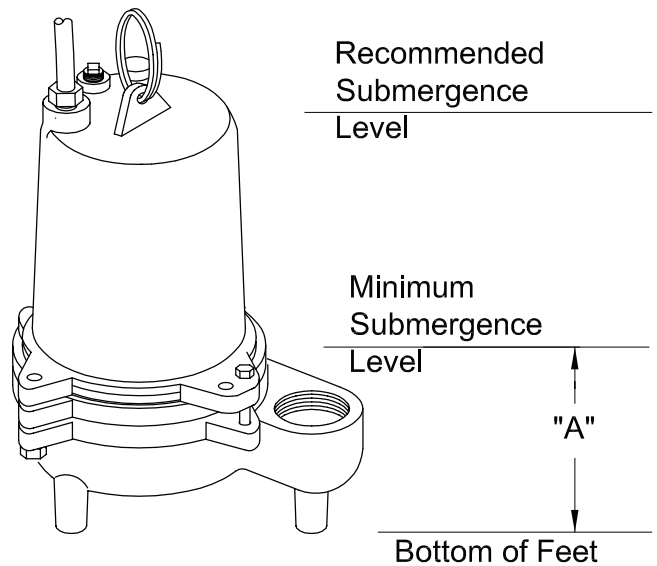

FIGURE 1

C-2) Discharge:

Discharge piping should be as short as possible. Both a check valve and a shut-off valve are recommended for each pump being used. The check valve is used to prevent backflow into the sump. Excessive backflow can cause flooding and/or damage to the pump. The shut-off valve is used to stop system flow during pump or check valve servicing.

Barnes Pumps supplies a Stainless Rail Package and also a variety of break-away fitting discharge systems designed to allow the submersible wastewater pump to be installed or removed without requiring personnel to enter the wet well. Contact your local Barnes Pumps distributor for complete details.

C-3) Liquid Level Controls:

Figure 2 shows a typical installation for any submersible pump using a level control mounted to the discharge piping with a piggy-back plug.

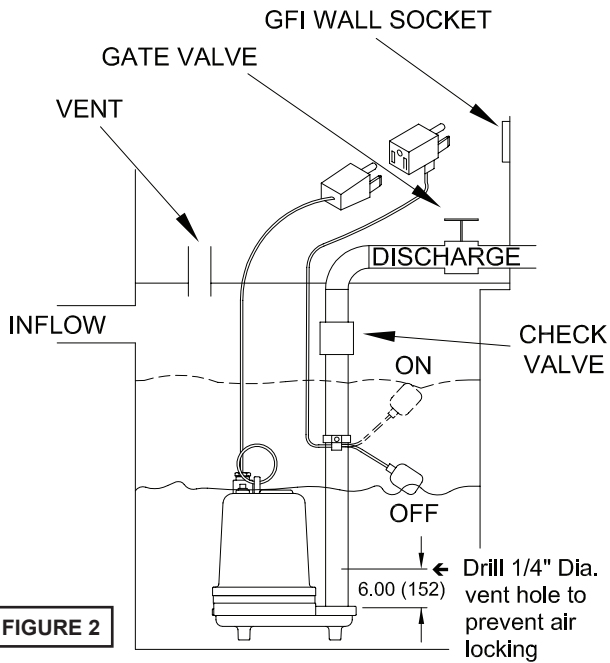

FIGURE 2

General Comments:

- 1) Never work in the sump with the power on.
- 2) Level controls are factory set for a pumping differential of 9 inches. If that is the cycle desired, simply circle the discharge pipe with the pipe mounting strap, feed the end through the worm drive, and tighten with a screwdriver. Be certain that the level control cannot hang up or foul in its swing. Also, make certain the pump impeller is still submerged when the level control is in the "OFF" mode.
- 3) If a higher pump differential is needed, grip the cord near the neck of the float, then using the other hand, exert a steady force on the lower edge of the cable clamp. The cable clamp should slide up to the new pivot point. Attach the level control to the discharge hose in the manner described above.
- 4) Plug the level control plug into the GFI receptacle, then plug the pump into the piggyback plug. One cycle of operation should be observed, so that any potential problems can be corrected.
- 5) It is recommended that the float should be set to insure that the sump well liquid level never drops below the top of the motor housing or a minimum level of 3 inches on BP Series and 6 inches on SE Series above the pump bottom.
- 6.) Figure 3 shows a typical connection for pumps with the wide angle float and piggy-back plug, for manual and automatic operations.

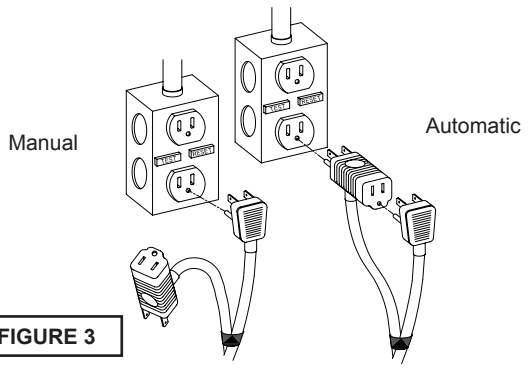

FIGURE 3

Automatic - Plug float cord into GFI outlet, then plug pump cord into float cord.
Manual - Plug pump cord directly into GFI outlet.

C-4) Electrical Connections:

C-4.1) Power Cable:
 The cord assembly mounted to the pump must not be modified in any way except for shortening to a specific application. Any splice between the pump and the control panel must be made in accordance with the electric codes. It is recommended that a junction box, if used, be mounted outside the sump or be of at least NEMA 4 (EEMAC-4) construction if located within the wet well. **Do not use the power cable to lift pump. NOTE: THE WHITE WIRE IS NOT A NEUTRAL OR GROUND LEAD, BUT A POWER CARRYING CONDUCTOR.**

C-4.2) Overload Protection:
Single Phase - The type of in-winding overload protector used is referred to as an inherent overheating protector and operates on the combined effect of temperature and current. This means that the overload protector will trip out and shut the pump off if the windings become too hot, or the load current passing through them becomes too high.

It will then automatically reset and start the pump up after the motor cools to a safe temperature. In the event of an overload, the source of this condition should be determined and rectified immediately. **DO NOT LET THE PUMP CYCLE OR RUN IF AN OVERLOAD CONDITION OCCURS !**

C-4.3) Wire Size:
 Consult a qualified electrician for proper wire size. See table for electrical information.

MODEL NO	HP	VOLT/ PH	Hz	RPM (Nom)	NEMA START CODE	FULL LOAD AMPS	LOCKED ROTOR AMPS	CORD SIZE	CORD TYPE	CORD O.D inch (mm)	WINDING RESISTANCE MAIN - START
BP314	1/3	115/1	60	1750	A	8.0	19.0	14/3	SJTOW	0.375 (9.5)	2.14 - 30.5
BP314A	1/3	115/1	60	1750	A	8.0	19.0	14/3	SJTOW	0.375 (9.5)	2.14 - 30.5
BP314AU	1/3	115/1	60	1750	A	8.0	19.0	14/3	SJTOW	0.375 (9.5)	2.14 - 30.5
BP314VF	1/3	115/1	60	1750	A	8.0	19.0	14/3	SJTOW	0.375 (9.5)	2.14 - 30.5
BP314BR	1/3	115/1	60	1750	A	8.0	19.0	14/3	SJTOW	0.375 (9.5)	2.14 - 30.5
BP314ABR	1/3	115/1	60	1750	A	8.0	19.0	14/3	SJTOW	0.375 (9.5)	2.14 - 30.5
BP314AUBR	1/3	115/1	60	1750	A	8.0	19.0	14/3	SJTOW	0.375 (9.5)	2.14 - 30.5
BP314VFBR	1/3	115/1	60	1750	A	8.0	19.0	14/3	SJTOW	0.375 (9.5)	2.14 - 30.5
BP324	1/3	230/1	60	1750	A	5.4	13.0	14/3	SJTOW	0.375 (9.5)	5.45 - 16.7
BP324AU	1/3	230/1	60	1750	A	5.4	13.0	14/3	SJTOW	0.375 (9.5)	5.45 - 16.7
BP324BR	1/3	230/1	60	1750	A	5.4	13.0	14/3	SJTOW	0.375 (9.5)	5.45 - 16.7
BP324AUBR	1/3	230/1	60	1750	A	5.4	13.0	14/3	SJTOW	0.375 (9.5)	5.45 - 16.7
BP314HT	1/3	115/1	60	1750	A	8.0	19.0	14/3	SOOW	0.560 (14.2)	2.14 - 30.5
BP314HTA	1/3	115/1	60	1750	A	8.0	19.0	14/3	SOOW	0.560 (14.2)	2.14 - 30.5
BP314HTAU	1/3	115/1	60	1750	A	8.0	19.0	14/3	SOOW	0.560 (14.2)	2.14 - 30.5
BP314HTBR	1/3	115/1	60	1750	A	8.0	19.0	14/3	SOOW	0.560 (14.2)	2.14 - 30.5
BP314HTABR	1/3	115/1	60	1750	A	8.0	19.0	14/3	SOOW	0.560 (14.2)	2.14 - 30.5
BP314HTAUBR	1/3	115/1	60	1750	A	8.0	19.0	14/3	SOOW	0.560 (14.2)	2.14 - 30.5
BP324HT	1/3	230/1	60	1750	A	5.4	13.0	14/3	SOOW	0.560 (14.2)	5.45 - 16.7
BP324HTAU	1/3	230/1	60	1750	A	5.4	13.0	14/3	SOOW	0.560 (14.2)	5.45 - 16.7
BP324HTBR	1/3	230/1	60	1750	A	5.4	13.0	14/3	SOOW	0.560 (14.2)	5.45 - 16.7
BP324HTAUBR	1/3	230/1	60	1750	A	5.4	13.0	14/3	SOOW	0.560 (14.2)	5.45 - 16.7
SE411	0.4	115/1	60	1750	C	12.0	19.0	16/3	SJTOW	0.310 (7.9)	2.14 - 30.5
SE411A	0.4	115/1	60	1750	C	12.0	19.0	16/3	SJTOW	0.310 (7.9)	2.14 - 30.5
SE411VF	0.4	115/1	60	1750	C	12.0	19.0	16/3	SJTOW	0.310 (7.9)	2.14 - 30.5
SE421	0.4	230/1	60	1750	C	6.2	13.0	14/3	SJTOW	0.375 (9.5)	5.45 - 16.7
SE411HT	0.4	115/1	60	1750	A	10.0	26.0	14/3	SOOW	0.560 (14.2)	1.37 - 15.2
SE411HTA	0.4	115/1	60	1750	A	10.0	26.0	14/3	SOOW	0.560 (14.2)	1.37 - 15.2
SE411HTAU	0.4	115/1	60	1750	A	10.0	26.0	14/3	SOOW	0.560 (14.2)	1.37 - 15.2
SE421HT	0.4	230/1	60	1750	A	4.0	13.0	14/3	SOOW	0.560 (14.2)	5.45 - 16.7
SE421HTAU	0.4	230/1	60	1750	A	4.0	13.0	14/3	SOOW	0.560 (14.2)	5.45 - 16.7
SE511	0.5	115/1	60	1750	A	12.0	26.0	14/3	SJTOW	0.375 (9.5)	1.37 - 15.2
SE511A	0.5	115/1	60	1750	A	12.0	26.0	14/3	SJTOW	0.375 (9.5)	1.37 - 15.2
SE511AU	0.5	115/1	60	1750	A	12.0	26.0	14/3	SJTOW	0.375 (9.5)	1.37 - 15.2
SE511VF	0.5	115/1	60	1750	A	12.0	26.0	14/3	SJTOW	0.375 (9.5)	1.37 - 15.2
SE521	0.5	230/1	60	1750	A	6.2	13.0	14/3	SJTOW	0.375 (9.5)	5.45 - 16.7
SE521AU	0.5	230/1	60	1750	A	6.2	13.0	14/3	SJTOW	0.375 (9.5)	5.45 - 16.7
SEV511	0.5	115/1	60	1750	A	12.0	26.0	14/3	SJTOW	0.375 (9.5)	1.37 - 15.2
SEV511A	0.5	115/1	60	1750	A	12.0	26.0	14/3	SJTOW	0.375 (9.5)	1.37 - 15.2
SEV511AU	0.5	115/1	60	1750	A	12.0	26.0	14/3	SJTOW	0.375 (9.5)	1.37 - 15.2
SEV511VF	0.5	115/1	60	1750	A	12.0	26.0	14/3	SJTOW	0.375 (9.5)	1.37 - 15.2
SEV521	0.5	230/1	60	1750	A	6.2	13.0	14/3	SJTOW	0.375 (9.5)	5.45 - 16.7
SEV521AU	0.5	230/1	60	1750	A	6.2	13.0	14/3	SJTOW	0.375 (9.5)	5.45 - 16.7

Winding Resistance \pm 5%. Pump rated for operation at \pm 10% voltage at motor.
Mechanical Switch on A, cord 16/2, SJOW, Piggy-Back Plug.
Mechanical Switch on AU, cord 14/2, SJOW
Vertical Switch on VF, cord 16/2, SJOW, Piggy-Back Plug
Mechanical Switch on HTA, cord 14/2, SJOOW, 0.370 (9.4MM) O.D., Piggy-Back Plug.
Mechanical Switch on HTAU, cord 14/2, SJOOW, 0.370 (9.4MM) O.D.

SECTION D: START-UP OPERATION

D-1) Check Voltage and Phase:

Before operating pump check to make sure that the voltage and phase information stamped on the pump's identification plate matches the available power.

D-2) Check Pump Rotation:

Before putting pump into service for the first time, the motor rotation must be checked. Improper motor rotation can result in poor pump performance and can damage the motor and/or pump. To check the rotation, suspend the pump freely, momentarily apply power and observe the "kickback". "Kickback" should always be in a counter-clockwise direction as viewed from the top of the pump ("kickback" is always opposite to impeller rotation). "Rotation" and "kickback" direction is noted on the pump motor housing.

D-2.1) Incorrect Rotation for Single-Phase:

In the unlikely event that the rotation is incorrect for a single-phase pump, contact a Barnes Pumps Service Center.

D-3) Identification Plate:

Record the numbers off the pump's identification plate onto the START-UP REPORT provided at the end of the manual for future reference.

D-4) Start-Up Report:

Included at the end of this manual are two start-up report sheets. These sheets are to be completed as applicable. Return one copy to Barnes Pumps and store the second in the control panel or with the pump manual if no control panel is used. It is important to record this data at initial start-up since it will be useful to compare to when servicing the pump in the future.

Insulation Test:

Before the pump is put into service, an insulation (megger) test should be performed on it. The ohm values as well as the volts and amps should be recorded on the start-up sheet and stored safely in the control panel or with the pump manual if no control panel is used.

Pump-Down Test:

After the pump has been properly wired and lowered into the basin, sump, or lift station, it is advisable to check the system by filling with liquid and allowing the pump to operate through its pumping cycle. The time needed to empty the system, or pump-down time, should be recorded on the start-up sheet.

SECTION E: PREVENTATIVE MAINTENANCE

As the motor is oil filled, no lubrication or other maintenance is required, and generally Barnes pumps will give very reliable service and can be expected to operate for years on normal sewage pumping without failure. However, as with any mechanical piece of equipment a preventive maintenance program is recommended and suggested to include the following checks:

- 1) Inspect motor chamber for oil level and contamination and repair as required per section F-1.
- 2) Inspect impeller and body for excessive build-up or clogging and repair as required per section F-2.
- 3) Inspect bearing and replace as required per section F-3.
- 4) Inspect seal for wear or leakage and repair as required per section F-4.

SECTION F: SERVICE AND REPAIR

NOTE: All item numbers () refer to Figures 14 & 15, for BP Series, 16 & 17 for SE series and 18 & 19 for SEV series.

F-1) Lubrication:

Anytime the pump is removed from operation and at least every twelve (12) months, the cooling oil in the motor housing (12) must be checked visually for oil level and contamination.

F-1.1) Checking Oil:

To check oil, set unit upright. Remove pipe plug (24). With a flashlight, visually inspect the oil in the motor housing (14) to make sure it is clean, clear and that the oil level is above all internal componentry. If oil appears satisfactory, replace pipe plug. If oil is low or appears contaminated, test oil as per section F-1.2.

F-1.2) Testing Oil:

1. Place pump on it's side, remove pipe plug (24) and drain oil into a clean, dry container.
2. Check oil for contamination using an oil tester with a range to 30 kilovolts breakdown.
3. If oil is found to be clean and uncontaminated (measures above 15 KV. breakdown), refill the motor housing as per section F-1.3.
4. If oil is found to be dirty or contaminated (or measures below 15KV. breakdown), then the pump must be carefully inspected for leaks at the shaft seal (3), cord inlet (9), o-ring (13), and pipe plug (24) before refilling with oil. To locate the leak, perform a pressure test as per section F-1.4. After leak is repaired, refill with new oil as per section F-1.3.

F-1.3 Replacing Oil in Motor Housing:

Drain all oil from motor housing and dispose of properly. Refill with 58 ounces of new cooling oil as per Table 1. An air space must remain in the top of the motor housing to compensate for air expansion. Set unit upright and fill only until oil level from top of pipe plug boss is $3" \pm 1/4"$.

When refilling with oil after servicing the shaft seal (3), a pressure test as per section F-1.4 should be done. If shaft seal was not disturbed during service, then apply pipe sealant and replace the pipe plug (24).



WARNING ! - DO NOT overfill oil. Overfilling of motor housing with oil can create excessive and dangerous hydraulic pressure which can destroy the pump and create a hazard. Overfilling oil voids warranty.

TABLE 1 - COOLING OIL - Dielectric	
SUPPLIER	GRADE
BP	Enerpar SE100
Conoco	Pale Paraffin 22
Mobile	D.T.E. Oil Light
G & G Oil	Circulating 22
Imperial Oil	Voltesso-35
Shell Canada	Transformer-10
Texaco	Diala-Oil-AX
Woco	Premium 100

F-1.4) Pressure Test:

Before checking the pump for leaks around the shaft seal, square ring, and cord inlet, the oil level should be full as described in section F1.3. Apply pipe sealant to the pressure gauge assembly and tighten into fill plug hole (see fig.4). Pressurize motor housing to 10 P.S.I. Use a soap solution around the sealed areas and inspect joints for "air bubbles". If, after five minutes, the pressure is still holding constant, and no "bubbles" are observed, slowly bleed the pressure and remove the gauge assembly. Replace the pipe plug using a sealant. If the pressure does not hold, then the leak must be located.

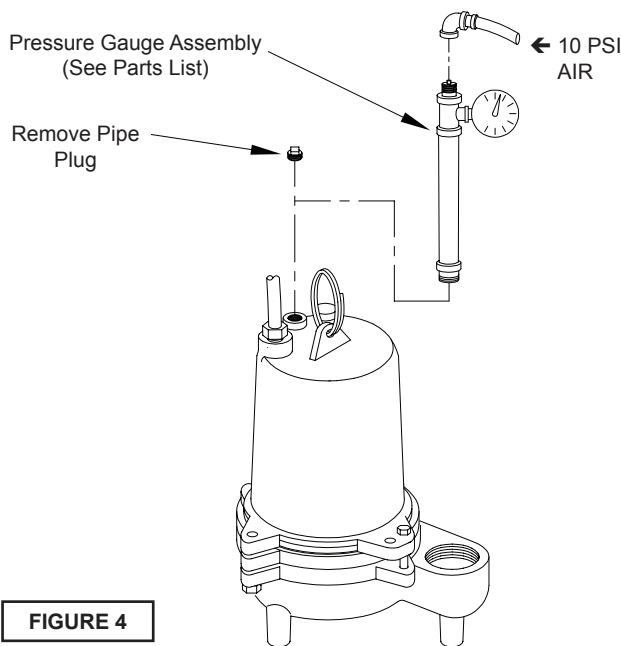

FIGURE 4

F-2) Impeller and Volute Service:

F-2.1) Disassembly and Inspection:

To clean out body (20), or to replace impeller (17), disconnect power, remove hex bolts (21), and vertically lift motor and seal assembly from body (20). Clean out body if necessary. Clean and examine impeller (17) for pitting or wear and replace if required. Inspect gasket (19) and replace if cut or damaged. The impeller (17) is threaded onto the shaft and to remove, unscrew impeller, holding shaft with a large screwdriver. Remove exclusion seal (16) and replace if needed.

F-2.2) Reassembly:

Before installing impeller (17), inspect threads on shaft and impeller to assure that they are clean. Place exclusion seal on shaft with the thin lip toward the motor (see section F-4.3). Apply a thread-locking compound to shaft threads and screw impeller onto shaft and tighten. Rotate impeller to check for binding. Position gasket (19) on body and install impeller and motor housing on pump body. Apply thread locking compound to each cap screw (21), thread into body, and torque to 11 ft. lbs. Check for free rotation of impeller.

F-3) Motor, Bearing and Cable Service

F-3.1) Disassembly and Inspection:

BP & SE Series, Motor - To examine or replace the motor (1) or bearing (4), remove body and impeller as per section F-2.1. Drain oil from motor housing as per section F-1.2. Remove gland nut (9a) and friction ring (9b) from motor housing (14). Pull cord through opening and disconnect the motor wires from the terminals on cable (9), see Figure 5. Remove socket head screws (15) and lift motor housing (14) from seal plate (2). Remove o-ring (13) and inspect for breaks. Loosen motor screws and pull motor (1) straight up and off seal plate (2). Inspect all parts for signs of wear and check motor resistance values.

On "AU" series pumps gland nut (29a) and friction ring (29b) must also be removed from motor housing (14) and pulled through opening and motor wires from the terminals on cable (2), see Figure 5.

BP-HT & SE-HT Series, Motor - To examine or replace the motor (1) or bearing (4), remove body and impeller as per section F-2.1. Drain oil from motor housing as per section F-1.2. Remove socket head screws (15) and loosen gland nut (9a) and push cord through while lifting motor housing (14) off of seal plate (2). Disconnect motor wires from cord set (9). Pull cord through motor housing along with two friction rings and one grommet. (See Figure 6). Remove o-ring (13) and inspect for breaks. Loosen motor screws and pull motor (1) straight up and off seal plate (2). Inspect all parts for signs of wear and check motor resistance values.

On "HTAU" series pumps gland nut (29a), must also be loosened from motor housing (14). Push cord through while lifting motor housing (14) off of seal plate (2). Disconnect motor wires from cord set (29). Pull cord through motor housing along with friction rings (29b) and grommet (29c), see Figure 6.

Check capacitor (7) with an Ohm meter by grounding the capacitor by placing a screwdriver across both terminals and then removing the screwdriver. Connect Ohm meter (set on high scale) to terminals, if needle moves to infinity (∞) then drifts back, the capacitor is good. If needle does not move or moves to infinity (∞) and does not drift back, replace capacitor (7).

STANDARD CONNECTIONS

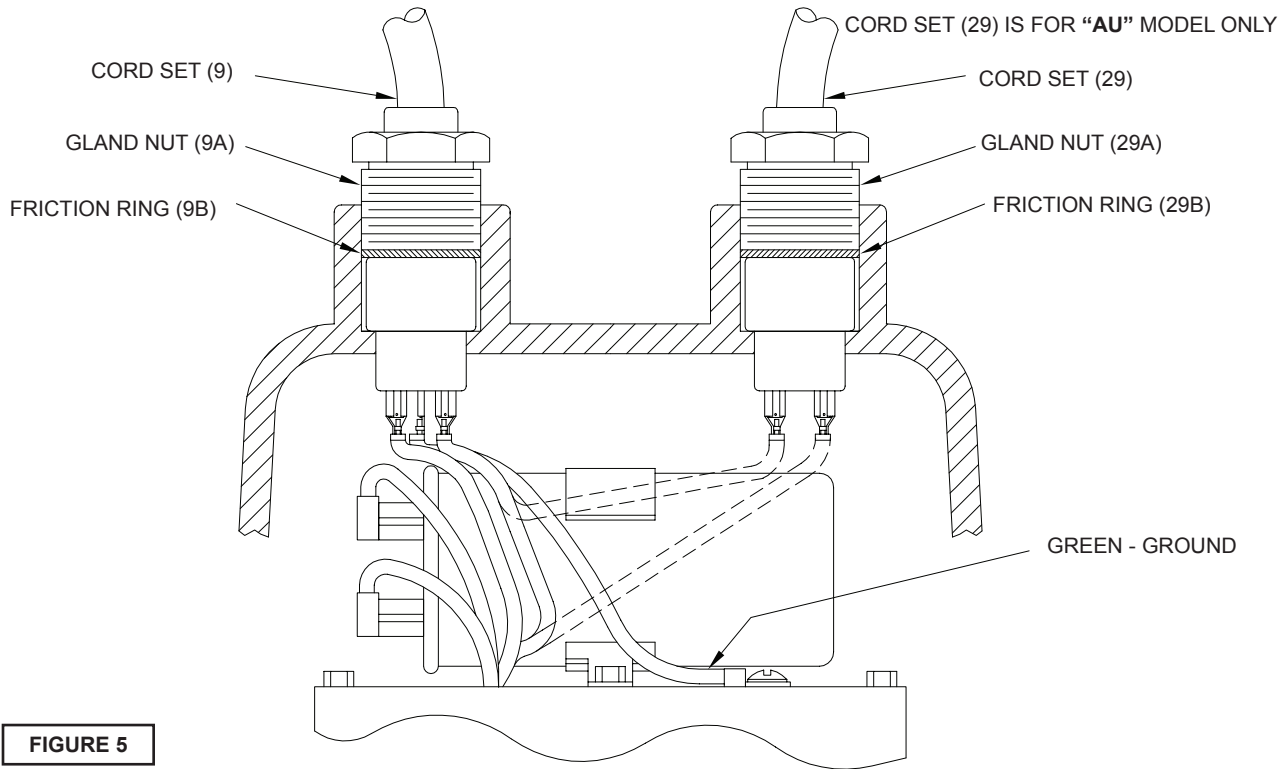

FIGURE 5

CORD SET FOR HIGH TEMPERATURE MODELS ONLY

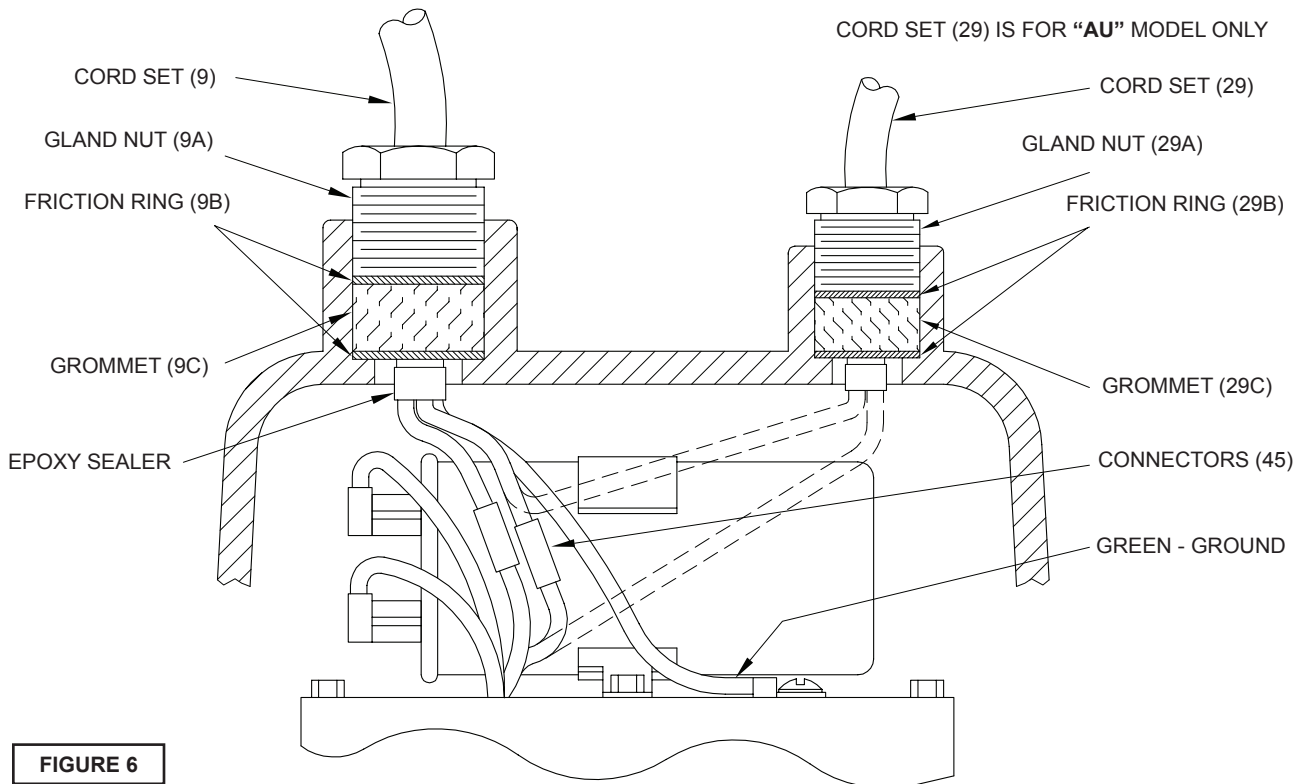

FIGURE 6

STANDARD CONNECTIONS

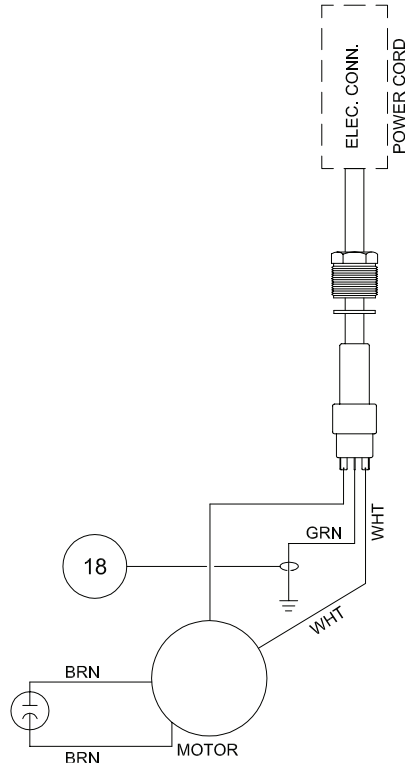

FIGURE 7

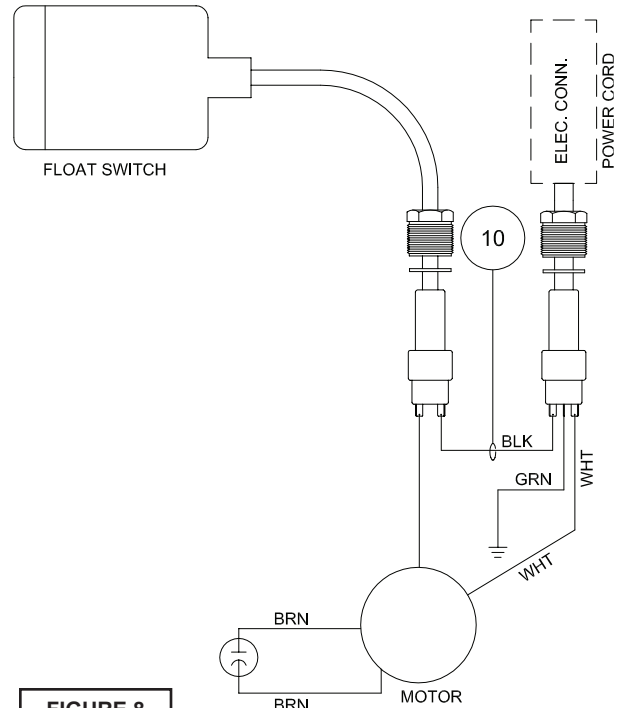

FIGURE 8

CORD SET FOR HIGH TEMPERATURE MODELS ONLY

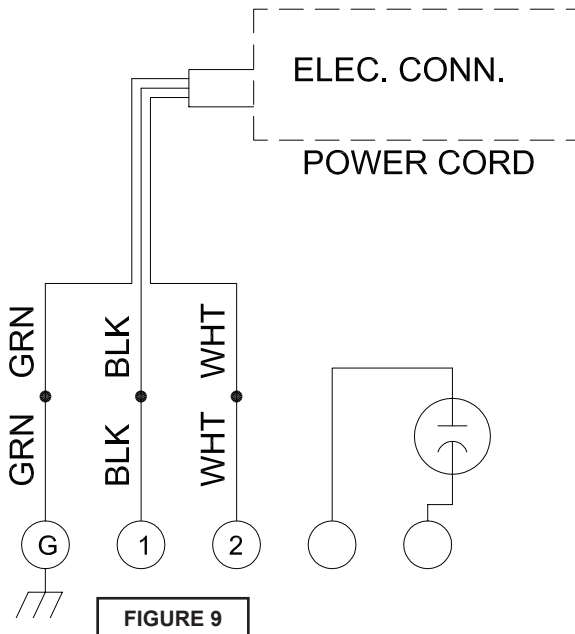

FIGURE 9

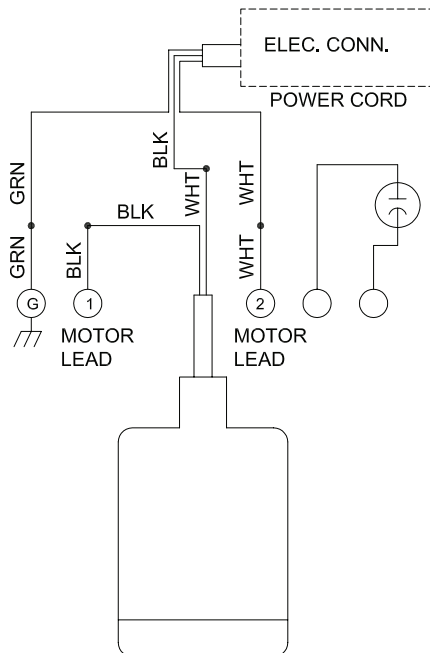
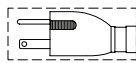
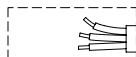

FIGURE 10

Electrical Connections:



MOLDED PLUG TO BE USED ON 115V UNITS



230V UNITS

Bearings - Disassemble motor as per section F-3.1. Remove snap ring (6) with snap ring pliers and pull motor (1) and lower bearing (4) straight off of seal plate (2). Inspect all parts for signs of wear and replace as needed.



CAUTION! Handle seal parts with extreme care. do not scratch or mar lapped surfaces.

F-3.2) Replacing Bearing:

When replacing bearing, be careful to not damage the rotor or shaft threads. Press the old bearing off the shaft with an arbor press or gear puller. Clean the shaft thoroughly. Apply adhesive compound to shaft and press new bearing on, pushing only on the inner race, until it seats against shoulder of shaft (see fig.12).



IMPORTANT! - All parts must be clean before reassembly.

F-3.3) Reassembly:

Make sure shaft seal (3) is clean and in proper position as per section F-4.2 before reassembling rotor and bearing. Slide lower bearing and rotor shaft squarely into the seal plate (2) until bearing seats on the bottom. Insert snap ring (6) into seal plate with flat edge against outer race of bearing. Place motor stator squarely onto seal plate (2) and tighten motor screws. Install o-ring (13) onto seal plate (2).

On **BP & SE Series**, slip motor wires through opening in motor housing (14) see Figure 5. Connect motor wires to cord set as per Figure 7. Place friction ring (9b) and gland nut (9a) into motor housing (14) and tighten gland nut to 17.5 ft. lbs. On **“AU”** series pumps slip float wires through opening in motor housing (14) and connect to float cable (29) see Figure 8. Place friction ring (29b) and gland nut (29a) into motor housing (14) and tighten gland nut to 17.5 ft. lbs.

Place motor housing (14) squarely onto seal plate (2). Tighten socket head screws (15) into motor housing. Refill with cooling oil as per paragraph F-1.3.

On **BP-HT & SE-HT Series**, slide the gland nut, friction rings and grommet onto cord set (see Figure 6) and slip cord through motor housing (14). Connect motor wires per Figure 9. Place motor housing (14) squarely onto seal plate while pulling excess cord through hole. Tighten socket head screws (15) into motor housing. Slide the friction rings (9b), grommet (9c) and gland nut (9a) into motor housing and tighten gland nut to 17.5 ft. lbs. Refill with cooling oil as per paragraph F-1.3. On **“HTAU”** series pumps slide the gland nut, friction rings and grommet onto cord set (see Figure 6) and slip cord (29) through motor housing (14). Connect wires per Figure 10.

F-4) Shaft Seal Service

F-4.1) Dissassembly and Inspection:

Disassemble pump motor as per section F-3.1. Inspect seal for signs of wear such as uneven wear pattern on the stationary member or chips and scratches on either sealing face. Do not interchange seal components. Replace entire seal if damage occurs.

F-4.2) Replacing Shaft Seal (refer to fig. 11, 12 & 13):

When replacing the shaft seal (3), remove used rotating member (3c), spring (3b), and spring retainer (3a) from motor shaft. Press used stationary member (3d) from the seal plate (2). At reassembly, clean seal cavity thoroughly and apply a light coat of oil. Lightly oil the rubber ring (**DO NOT use grease**) and press the stationary member firmly into the seal plate using a seal pusher (See Parts List-Seal Tool Kit), nothing but pusher to come in contact with seal face (see Fig. 11). Insert so that the finished surface is up and the grooved surface is against the seal plate. Make sure the stationary member is in straight and that the rubber ring is not out of it's groove.

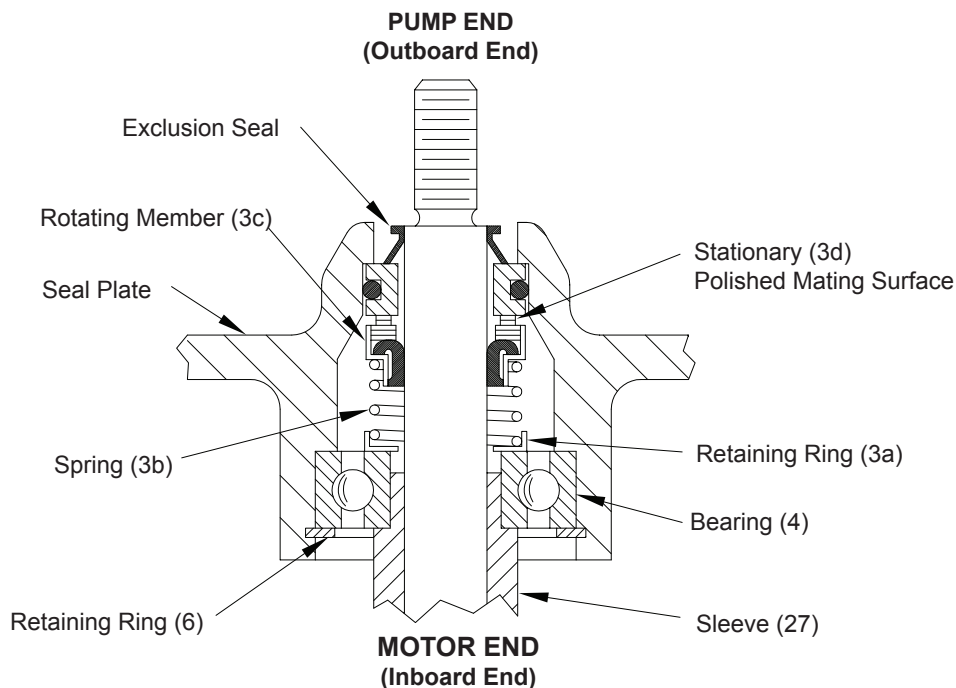

FIGURE 12

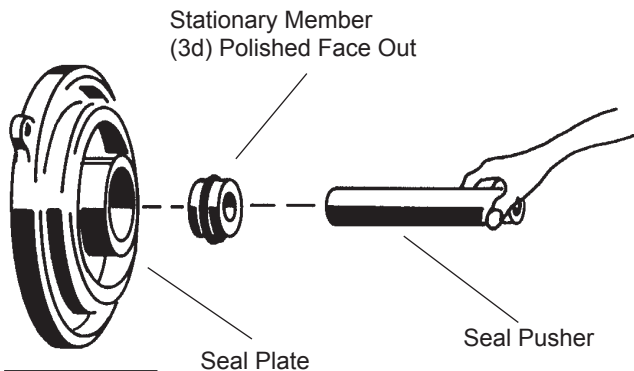

FIGURE 11



DO NOT HAMMER ON THE SEAL PUSHER - IT WILL DAMAGE THE SEAL FACE.

Place spring retainer and spring onto motor shaft. Lightly oil shaft (**DO NOT use grease**) and inner surface of bellows of rotating member. With finished end away from motor, slide rotating member over bullet and onto shaft until it engages spring (see Fig. 13). Carefully assemble shaft to seal plate as per section F-3.3. It is extremely important to keep seal faces clean during assembly. Dirt particles lodged between these faces will cause the seal to leak. When seal plate is assembled to motor, it will properly align and seat the seal (3) and bearing (4). Follow complete reassembly instructions as per section F-3.3.

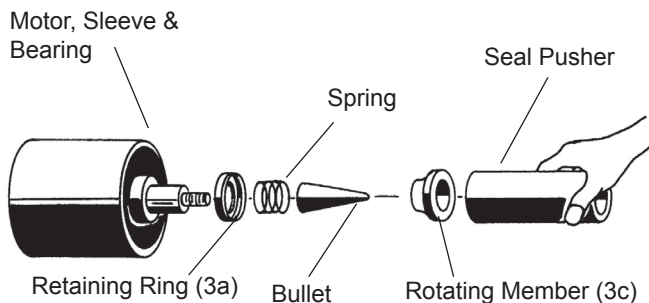

FIGURE 13

F-4.3) Replacing Exclusion Seal:

The exclusion seal (16), helps to keep debris away from the shaft seal where it could cause damage. The exclusion seal should be replaced whenever the shaft seal is replaced. To replace the exclusion seal, pull the old seal off the shaft, and slide the new seal on with the thin lip toward the motor. Be sure not to damage the lip of the seal. Finger pressure is all that is needed to install the exclusion seal.

SECTION: G REPLACEMENT PARTS

G-1 ORDERING REPLACEMENT PARTS:

When ordering replacement parts, ALWAYS furnish the following information:

1. Pump serial number and date code. (Paragraph G-4)
2. Pump model number. (Paragraph G-3)
3. Pump part number. (Paragraph G-2)
4. Part description.
5. Item part number.
6. Quantity required.
7. Shipping instructions.
8. Billing Instructions.

CRANE PUMPS & SYSTEMS 105500	HP.	Volts	Code	Ph.	Hz.	BARNIES
	RPM	FLA	Model No. 2			
	Part No. 3	Serial No. 1				
	Impeller Dia.	Max. Liq. Temp. °C	Ins. Class			
<p>WARNING TO REDUCE RISK OF ELECTRICAL SHOCK DISCONNECT THE PUMP FROM THE POWER SOURCE BEFORE HANDLING OR SERVICING. SEE INSTRUCTION MANUAL FOR PROPER INSTALLATION. SEE WARNING PLATE FOR ADDITIONAL CAUTIONS.</p>						

G-2 PART NUMBER:

The part number consists of a six (6) digit number, which appears in the catalog. A one or two letter suffix may follow this number to designate the design configuration. This number is used for ordering and obtaining information.

G-3 MODEL NUMBER:

This designation consists of numbers and letters which represent the discharge size, series, horsepower, motor phase and voltage, speed and pump design. This number is used for ordering and obtaining information.

G-4 SERIAL NUMBER:

The serial number block will consist of a six digit number, which is specific to each pump and may be preceded by an alpha character, which indicates the plant location. This number will also be suffixed with a four digit number, which indicates the date the unit was built (Date Code). **EXAMPLE: A012345 0490.**

Reference the six digit portion (Serial Number) of this number when referring to the product.

TROUBLE SHOOTING

CAUTION ! Always disconnect the pump from the electrical power source before handling.
 If the system fails to operate properly, carefully read instructions and perform maintenance recommendations.
 If operating problems persist, the following chart may be of assistance in identifying and correcting them:
MATCH “CAUSE” NUMBER WITH CORRELATING “CORRECTION” NUMBER.

NOTE: Not all problems and corrections will apply to each pump model.

PROBLEM	CAUSE	CORRECTION
Pump will not run	1. Poor electrical connection, blown fuse, tripped breaker or other interruption of power, improper power supply. 2. Motor or switch inoperative (to isolate cause, go to manual operation of pump). 2a. Float movement restricted. 2b. Switch will not activate pump or is defective. 2c. Defective motor 3. Insufficient liquid level.	1. Check all electrical connections for security. Have electrician measure current in motor leads, if current is within $\pm 20\%$ of locked rotor Amps, impeller is probably locked. If current is 0, overload may be tripped. Remove power, allow pump to cool, then recheck current. 2a. Reposition pump or clean basin as required to provide adequate clearance for float. 2b. Disconnect level control. Set ohmmeter for a low range, such as 100 ohms full scale and connect to level control leads. Actuate level control manually and check to see that ohmmeter shows zero ohms for closed switch and full scale for open switch. (Float Switch). 2c. Check winding insulation (Megger Test) and winding resistance. If check is outside of range, dry and recheck. If still defective, replace per service instructions.
Pump will not turn off	2a. Float movement restricted. 2b. Switch will not activate pump or is defective. 4. Excessive inflow or pump not properly sized for application. 9. Pump may be airlocked 14. H-O-A switch on panel is in “HAND” position	3. Make sure liquid level is at least equal to suggested turn-on point. 4. Recheck all sizing calculations to determine proper pump size. 5. Check discharge line for restrictions, including ice if line passes through or into cold areas. 6. Remove and examine check valve for proper installation and freedom of operation. 7. Open valve.
Pump hums but does not run	1. Incorrect voltage 8. Impeller jammed or loose on shaft, worn or damaged, impeller cavity or inlet plugged.	8. Check impeller for freedom of operation, security and condition. Clean impeller and inlet of any obstruction. 9. Loosen union slightly to allow trapped air to escape. Verify that turn-off level of switch is set so that the suction is always flooded. Clean vent hole.
Pump delivers insufficient capacity	1. Incorrect voltage. 4. Excessive inflow or pump not properly sized for application. 5. Discharge restricted. 6. Check valve stuck closed or installed backwards. 7. Shut-off valve closed. 8. Impeller jammed or loose on shaft, worn or damaged, impeller cavity or inlet plugged. 9. Pump may be airlocked. 10. Pump running backwards	10. Check rotation. If power supply is three phase, reverse any two of three power supply leads to ensure proper impeller rotation.. 11. Repair fixtures as required to eliminate leakage.
Pump cycles too frequently or runs periodically when fixtures are not in use	6. Check valve stuck closed or installed backwards. 11. Fixtures are leaking. 15. Ground water entering basin.	12. Check pump temperature limits & fluid temperature. 13. Replace portion of discharge pipe with flexible connector. 14. Turn to automatic position.
Pump shuts off and turns on independent of switch, (trips thermal overload protector). CAUTION! Pump may start unexpectedly. Disconnect power supply.	1. Incorrect voltage. 4. Excessive inflow or pump not properly sized for application. 8. Impeller jammed, loose on shaft, worn or damaged, impeller cavity or inlet plugged. 12. Excessive water temperature. (internal protection only)	15. Check for leaks around basin inlet and outlets.
Pump operates noisily or vibrates excessively	2c. Worn bearings, motor shaft bent. 8. Debris in impeller cavity or broken impeller 10. Pump running backwards 13. Piping attachments to building structure too rigid or too loose.	

SERIES: BP314 & BP324

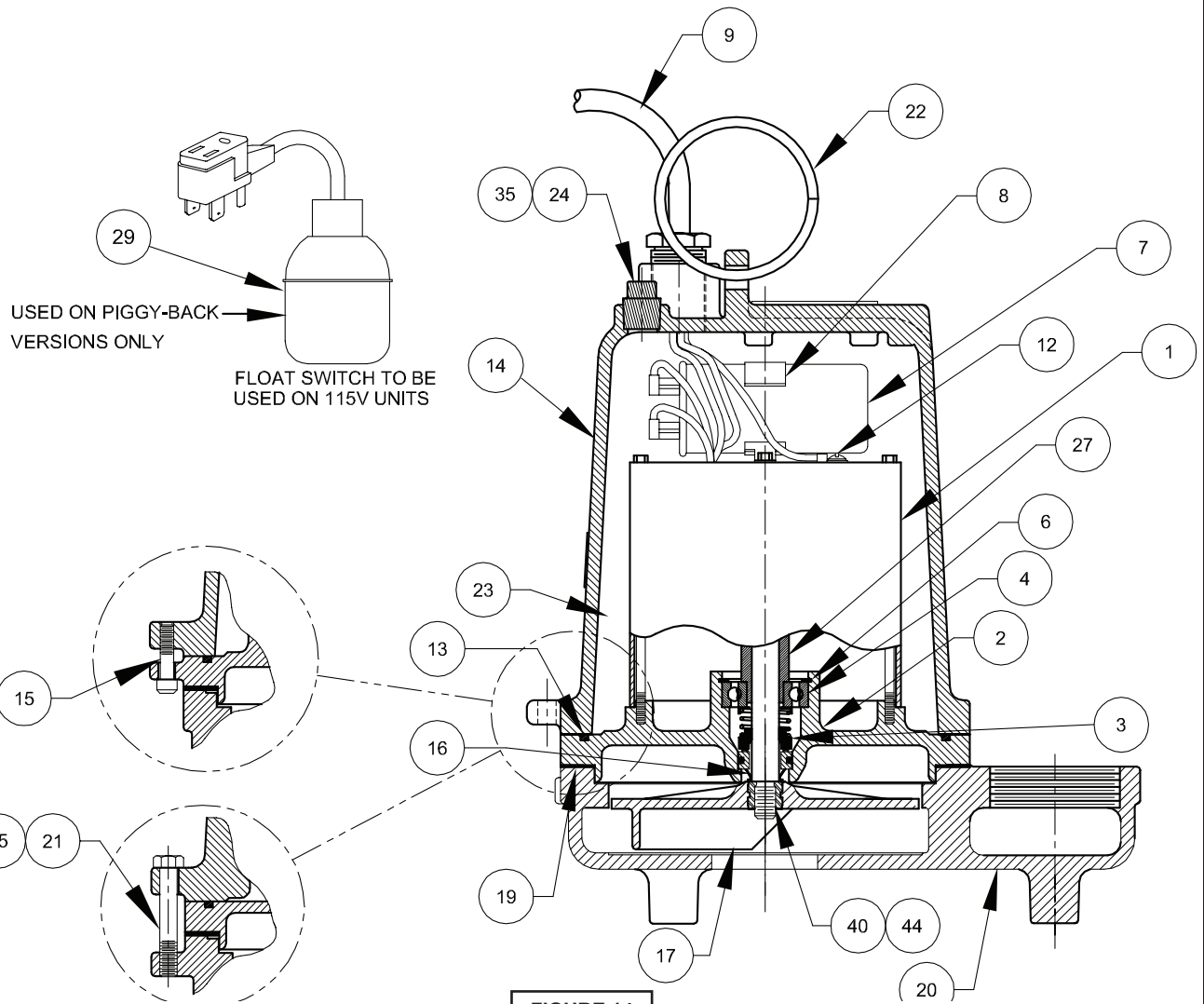
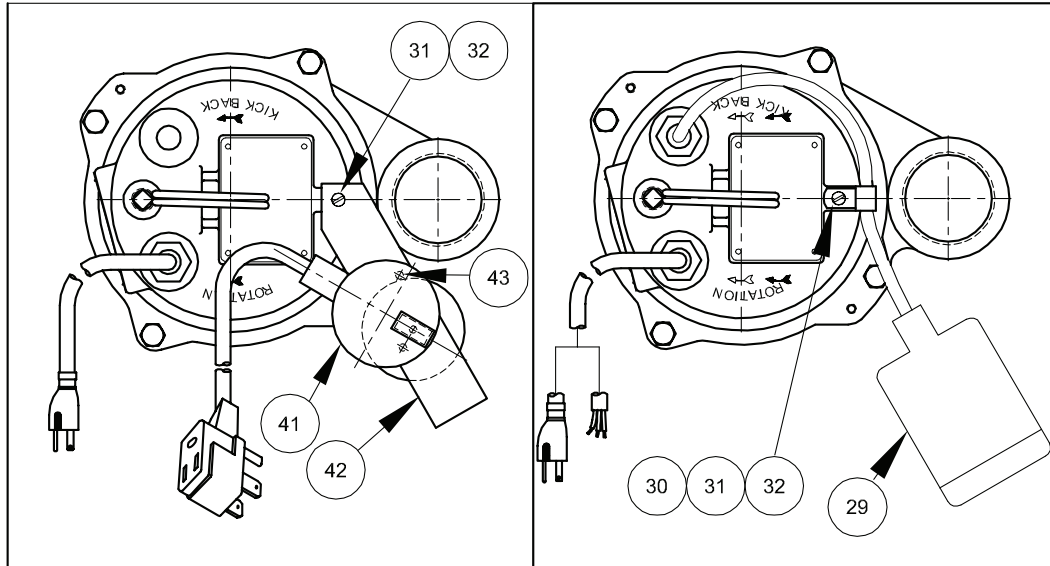

FIGURE 14

SERIES: BP314 & BP324

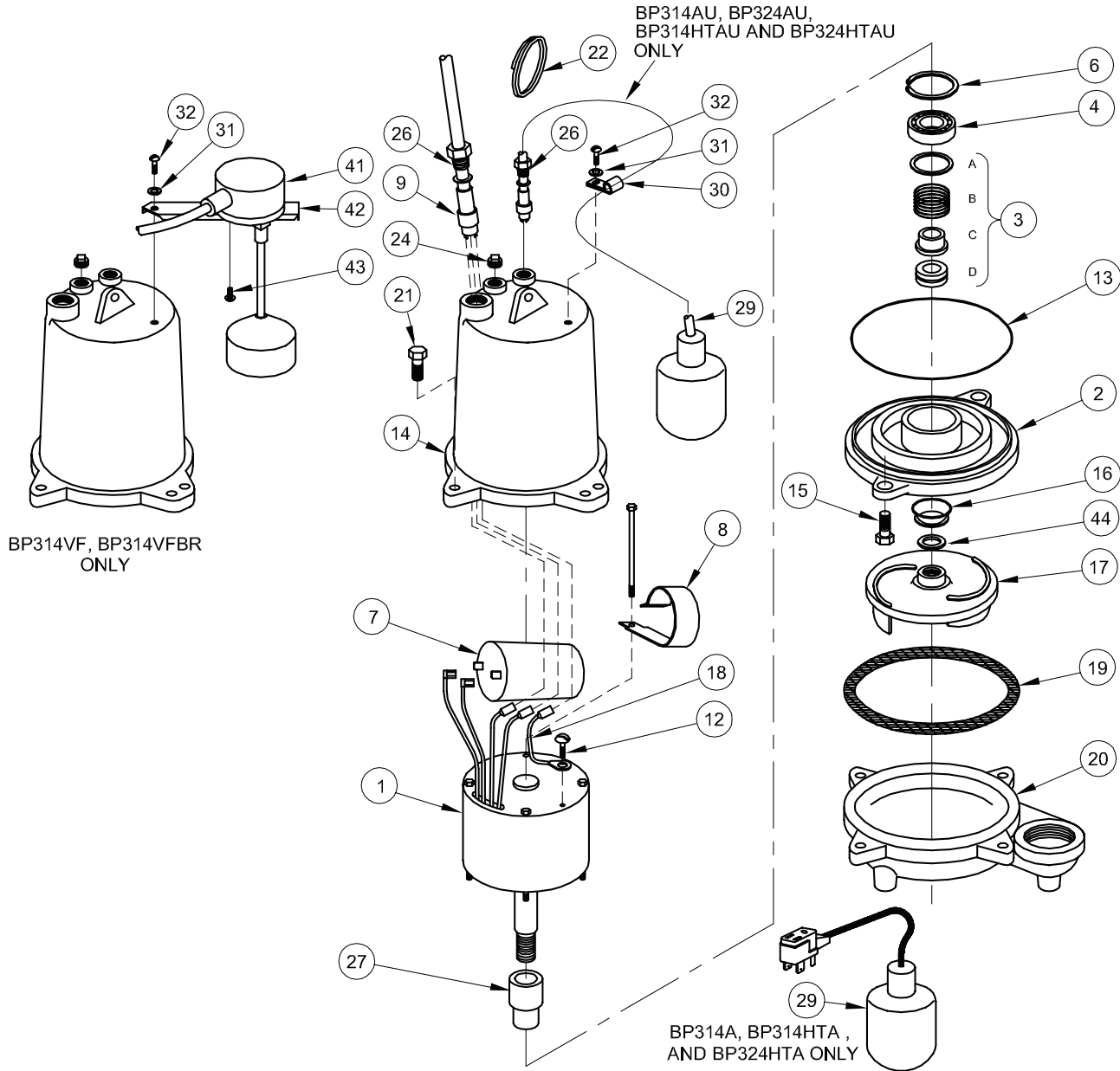

FIGURE 15

SERIES: BP314 & BP324

PARTS KITS

Overhaul Kit..... P/N: 085201 (†) 3,4,6,13,16,19,24

Seal Kit..... P/N: 085202 (◇) 3,13,16,19

Pressure Gauge Kit....P/N: 085343

PARTS LIST

ITEM	QTY	PART No.	DESCRIPTION	
1	1	See TABLE 2	Motor & Sleeve	
2	1	093063	Seal Plate, BP Series	Cast Iron
		093247	Seal Plate, BP-BR Series	Bronze
3	1	068988	◇† Shaft Seal, (Standard)	Carbon/Ceramic/Buna-N
		068988SB	Tungsten/Tungsten/Buna-N	
		068988SD	Silicon/Silicon/Buna-N	
4	1	017414	† Bearing	
6	1	017415	† Retaining Ring	
7	1	112985	‡ Capacitor, BP314	300V 35MFD
		070965	Capacitor, BP324	370V 25MFD
8	1	039858	Capacitor Bracket	
----STANDARD TEMPERATURE----				
9	1	See TABLE 3	Power Cable Assembly	
9a	1	051448	* Gland Nut	1-16
9b	2	051449	* Friction Ring	
----HIGH TEMPERATURE----				
9	1	See TABLE 3	Power Cable Assembly	
9a	1	051448	* Gland Nut	1-16
9b	2	051449	* Friction Ring	
9c	1	051451	* Grommet (High Temp.)	
10	1	099290	Jumper Wire Assy.	"AU" Series
12	1	016660	Self Tapping Screw	8-32 x 3/8 lg Stainless
13	1	019289	◇† O-Ring	
14	1	See TABLE 2	Motor Housing	
15	2	11-32-1	Socket Hd. Cap Screw	1/4-20 x 1.25" Stainless
16	1	068053	◇† Exclusion Seal	
17	1	096725	Impeller, BP Series	5.63" Dia., Polypropylene
		096721	Impeller, BP-BR & Hi-Temp	5.63" Dia., Bronze
18	1	099295	Ground Wire Assy	
19	1	068984	◇† Gasket	
20	1	096724	Volute, BP	Cast Iron
	1	096724B	Volute, BP-BR	Bronze
21	4	1-140-1	Cap Screw	5/16-18 x 2.00" Stainless
22	1	027271	Handle	
23	58 oz	029034	Oil	
24	1	015000	† Pipe Plug	
25	A/R	----	Loctite	#RC609
26	A/R	----	Loctite	#242
27	1	----	Bearing Sleeve	PART OF MOTOR ASSEMBLY

(*) Included with item 9

(‡) Units with a Build Code date before 11/01 may use capacitor Part Number 070964 or 035864

SERIES: BP314 & BP324

29	1	Float Switch w/Plug, Mechanical, Series: A & ABR		
		101758		15FT
		101758XA	20FT	
		101758XC	30FT	
		101758XF	50FT	
29	1	Float Switch High Temp w/Plug, Series: HTA & HTABR		
		090269	15FT	
		090269XB	25FT	
		090269XC	30FT	
		090269XF	50FT	
29	1	099262	Float Switch, Mechanical	Series: AU, & AUBR
29	1	090622	Float Switch High Temp, Mech.	Series: HTAU & HTAUBR

ITEMS 29A thru 35 ARE FOR MODELS: AU, AUBR, USED WITH 099262 FLOAT.

29a	1	051448	Gland Nut	1-16
29b	1	051449	Friction Ring	
30	1	090516	Cord Clip	
31	1	20-12-1	Lockwasher	#10 Stainless
32	1	2-88-1	Rd Hd Screw	10-32 x 3/8 Lg. Stainless
35	A/R	----	Permatex Sealant #2C	

ITEMS 29A thru 35 ARE FOR MODELS: HTAU, HTAUBR, USED WITH 090622 FLOAT.

29a	1	051762	Gland Nut	1-16 Stainless
29b	2	089121	Friction Ring	
29c	1	090103	Grommet	
30	1	090516	Cord Clip	
31	1	20-12-1	Lockwasher	#10 Stainless
32	1	2-88-1	Rd Hd Screw	10-32 x 3/8 Lg. Stainless
35	A/R	----	Permatex Sealant #2C	

40	A/R	----	Loctite, #242	
41	1	100829	Vertical Float Switch	Series: VF & VFBR
42	1	100547	Mounting Bracket	
43	2	021337	Pan Hd, Self-Taping Screw	10-16, Stainless
44	1	098679	Shim, .030"	
45	2	See BOM	Connector	Hi-Temp Only
	3	See BOM	Connector	(HTAU) Hi-Temp Only
46	2	022229	Shrink Tube	Hi-Temp Only
	3	022229	Shrink Tube	(HTAU) Hi-Temp Only

SERIES: BP314 & BP324

TABLE 2 - MOTOR and HOUSING

PUMP MODEL	MOTOR HOUSING (Item #14)	MOTOR SLEEVE (Item #1)
BP314	093065	102260
BP314A	093065	102260
BP314AU	093066	102260
BP314VF	093065	102260
BP314BR	093211	102260
BP314ABR	093211	102260
BP314AUBR	093212	102260
BP314VFBR	093211	102260
BP324	093065	098835
BP324AU	093066	098835
BP324BR	093211	098835
BP324AUBR	093212	098835
BP314HT	093065	102260
BP314HTA	093065	102260
BP314HTAU	093066	102260
BP314HTBR	093211	102260
BP314HTABR	093211	102260
BP314HTAUBR	093212	102260
BP324HT	093065	098835
BP324HTAU	093066	098835
BP324HTBR	093211	098835
BP324HTAUBR	093066	098835

TABLE 3 - POWER CORDS SETS

MODELS/ LENGTH	ITEM #9 BP314 Series	ITEM #9 BP324 Series	ITEM #9 BP314HT Series	ITEM #9 BP324HT Series
15 FT (5m) STD	099260	099261	100502	100525
20 Ft. (6m)	099260XA	099261XA	-	-
25 Ft. (7.5m)	-	-	100502XB	100525XB
30 Ft. (9m)	099260XC	099261XC	-	-
50 Ft. (15m)	099260XF	099261XF	100502XF	100525XF

SERIES: SE

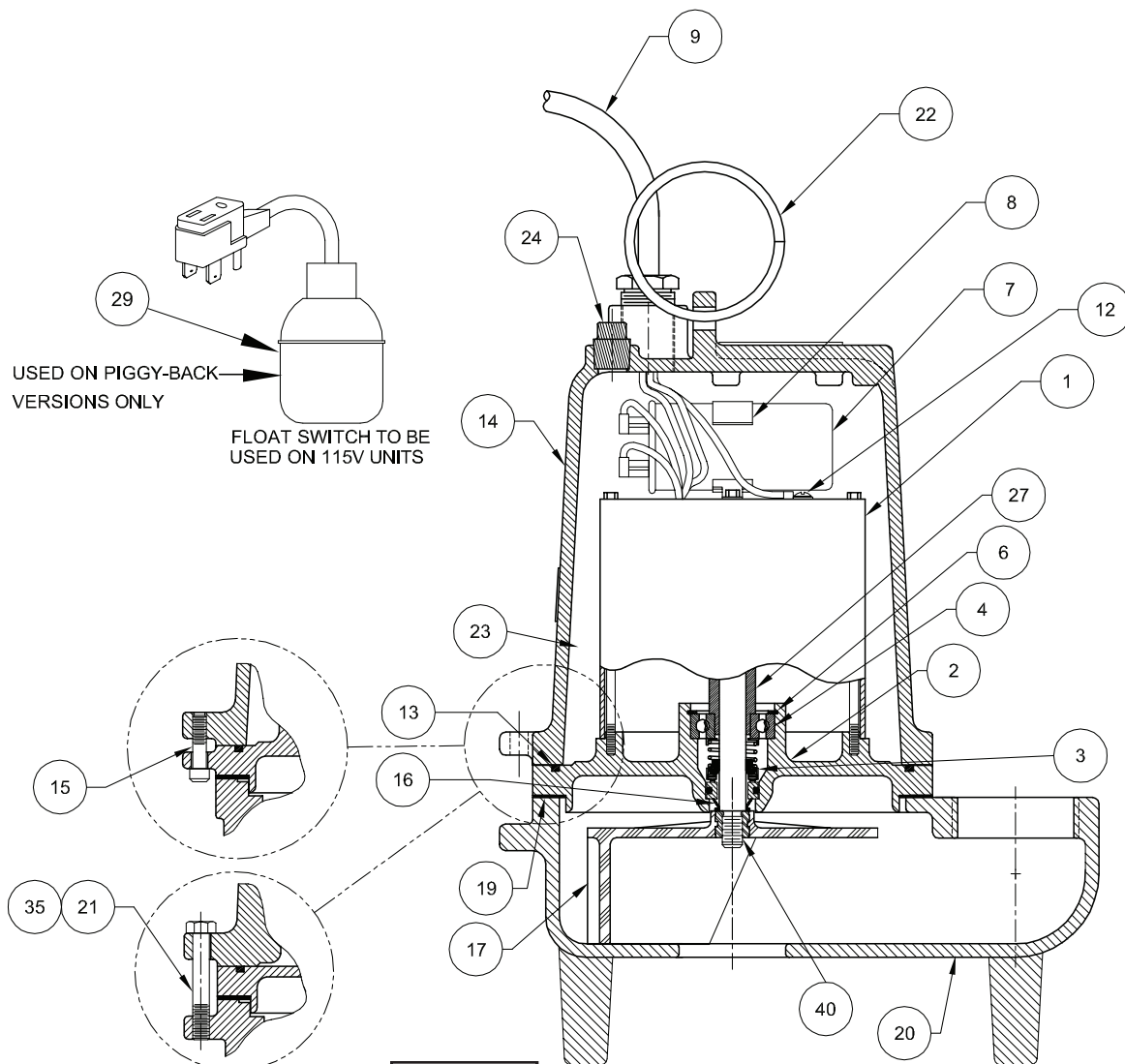
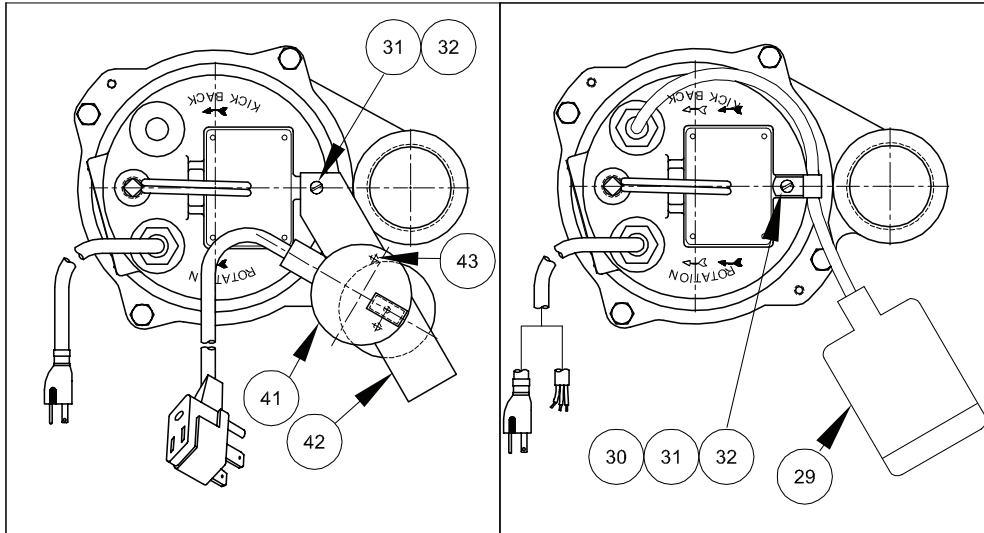

FIGURE 16

SERIES: SE

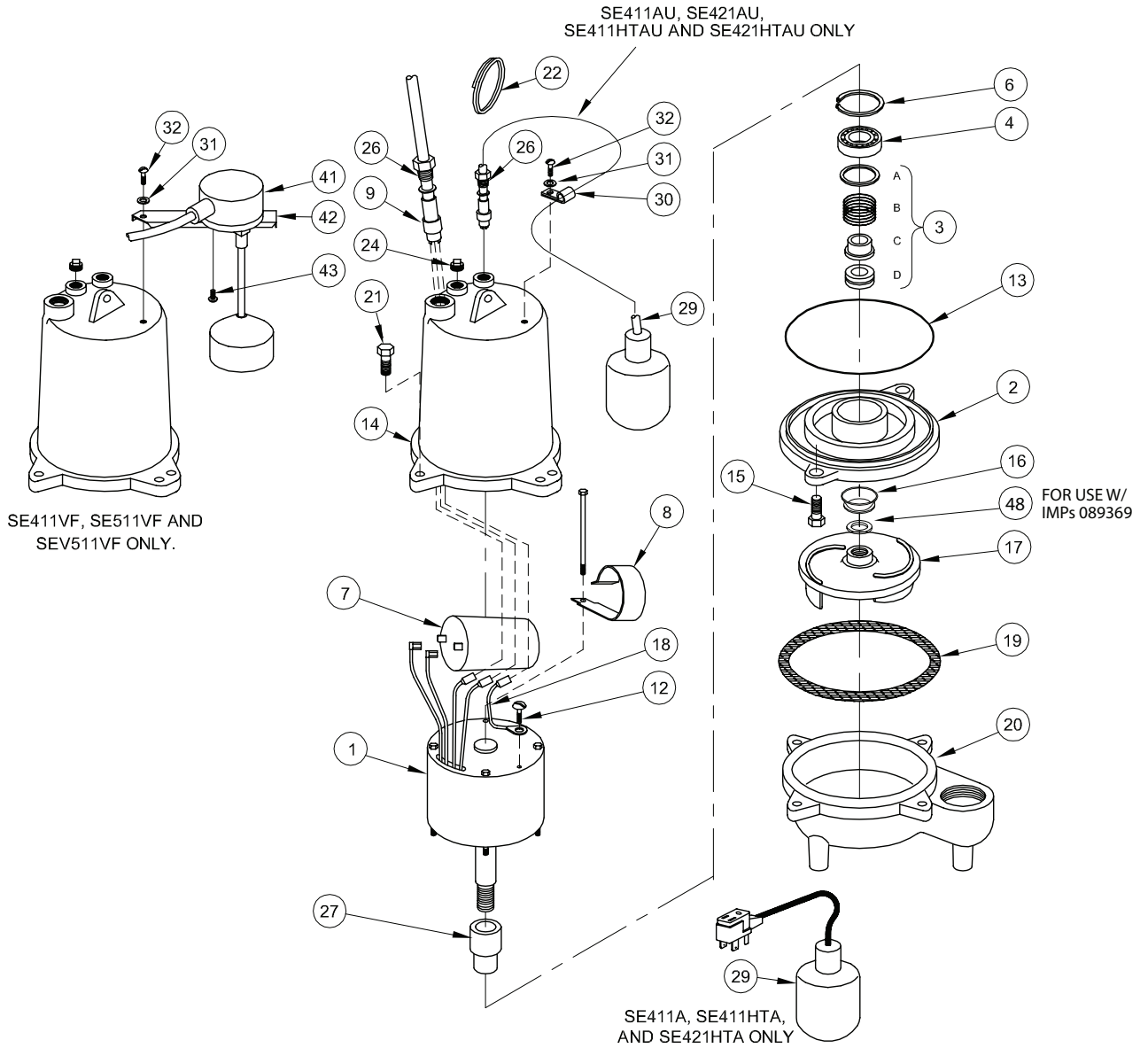

FIGURE 17

SERIES: SEV

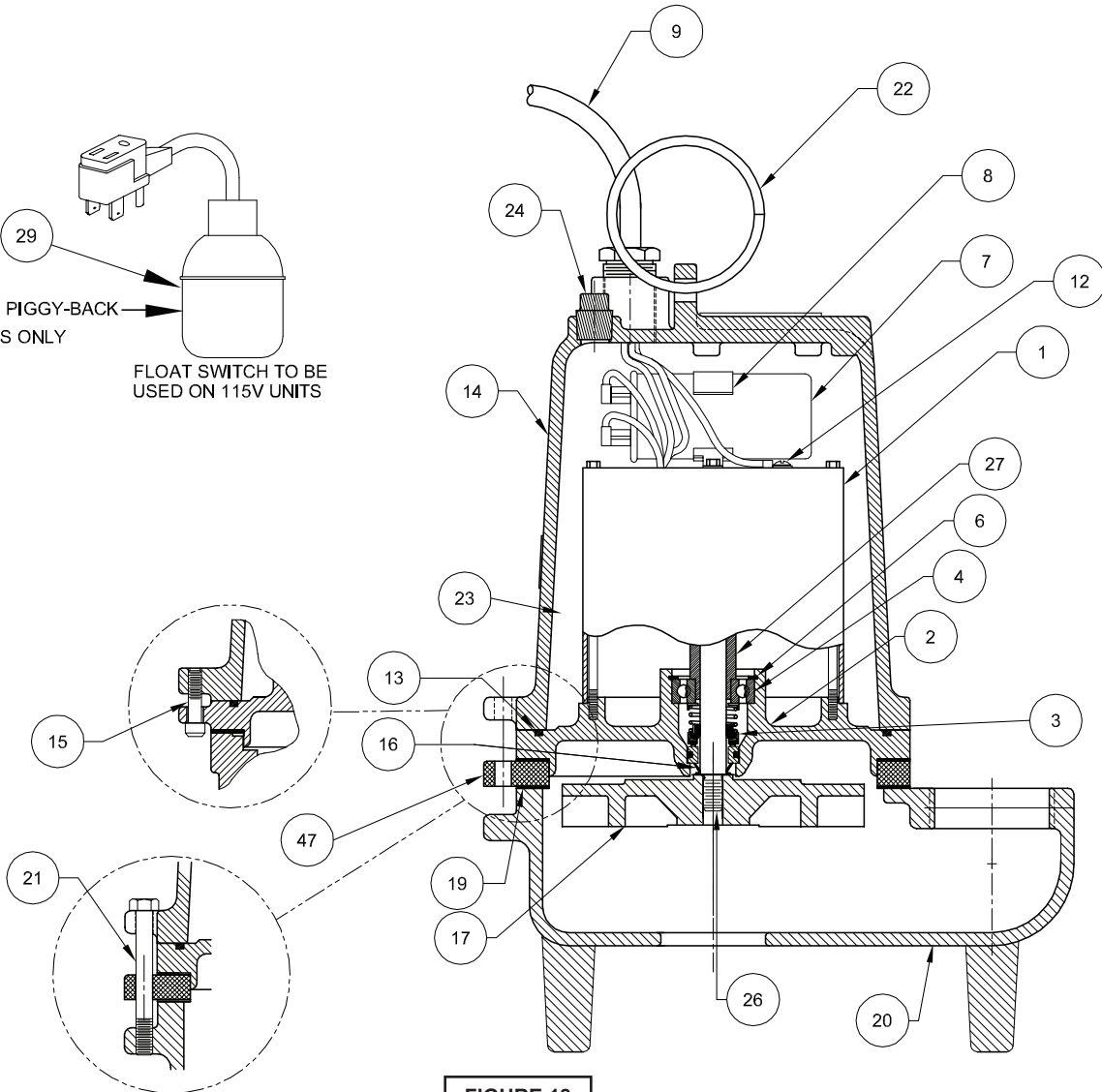
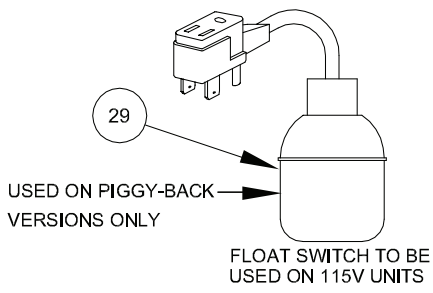
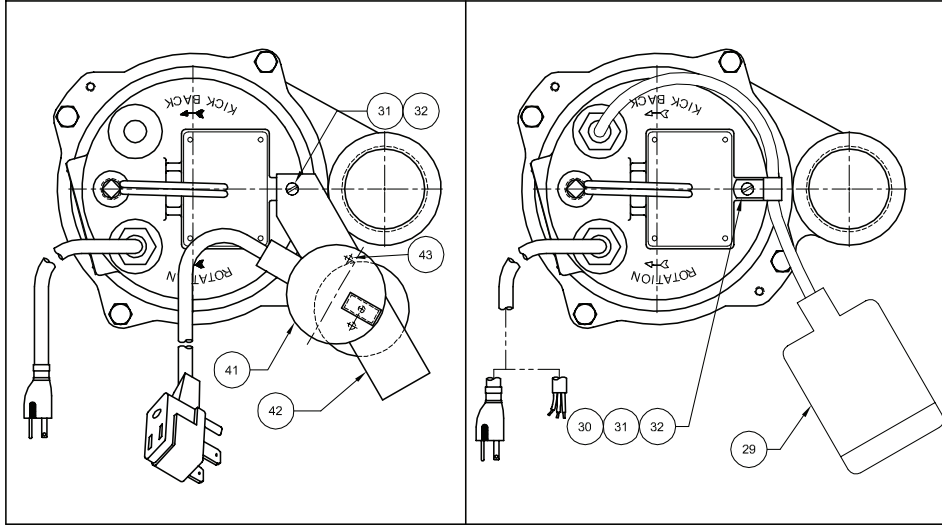

FIGURE 18

SERIES: SEV

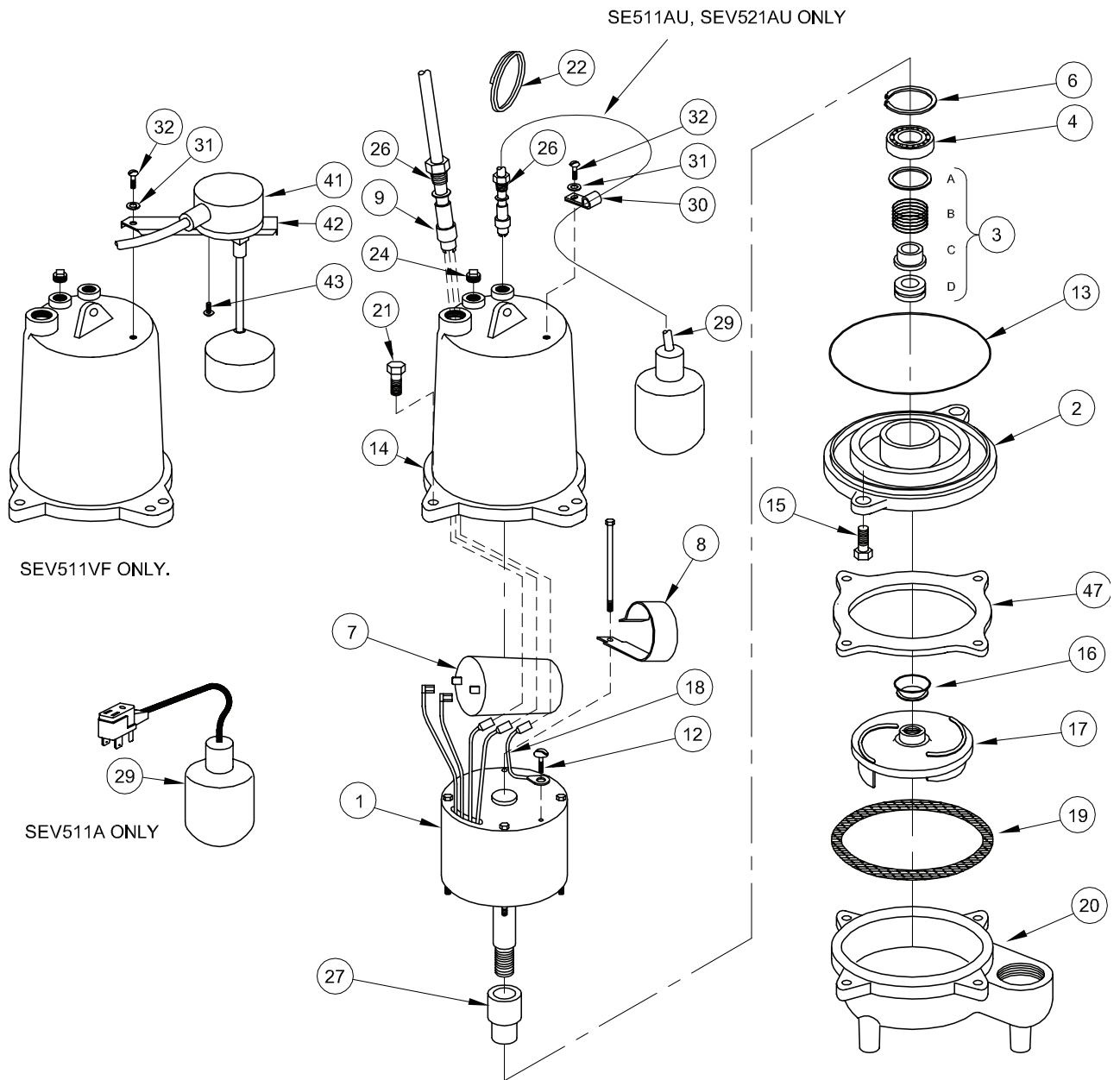

FIGURE 19

SERIES: SE & SEV

PARTS KITS

Overhaul Kit..... P/N: 085201 (†) 3,4,6,13,16,19,24

Seal Kit..... P/N: 085202 (◇) 3,13,16,19

PRESSURE GAUGE KIT.. P/N: 085343

PARTS LIST

ITEM	QTY	PART No.	DESCRIPTION	
1	1	See TABLE 2	Motor & Sleeve	
2	1	093063	Seal Plate	Cast Iron
3	1	068988	◇† Shaft Seal, (Standard)	Carbon/Ceramic/Buna-N
		068988SB	Tungsten/Tungsten/Buna-N	
		068988SD	Silicon/Silicon/Buna-N	
4	1	017414	† Bearing	
6	1	017415	† Retaining Ring	
7	1	112985	‡ Capacitor, SE411	300V 35MFD
		070965	Capacitor, SE421 & Hi-Temp	370V 25MFD
		070965	Capacitor, SE511-521, SEV511-521,	370V 25MFD
8	1	039858	Capacitor Bracket	
----STANDARD TEMPERATURE----				
9	1	See TABLE 3	Power Cable Assembly	
9a	1	051448	* Gland Nut	1-16
9b	2	051449	* Friction Ring	
----HIGH TEMPERATURE----				
9	1	See TABLE 3	Power Cable Assembly	
9a	1	051448	* Gland Nut	1-16
9b	2	051449	* Friction Ring	
9c	1	051451	* Grommet	
10	1	099290	Jumper Wire Assy. "AU" Series	
12	1	016660	Self Tapping Screw	8-32 x 3/8 lg Stainless
13	1	019289	◇† O-Ring	
14	1	See TABLE 2	Motor Housing	
15	2	084948	Socket Hd. Cap Screw	1/4-20 x 1.25" Stainless
16	1	068053	◇† Exclusion Seal	
17	1	112561	Impeller, SE411-421	5.44" Dia., Cast Iron**
		089369TG	Impeller, SE411-421 Hi-Temp	4.50" Dia., Cast Iron
		096722	Impeller, SE511-521	5.63" Dia., Cast Iron
		096723CI	Impeller, SEV511-521	5.63" Dia., Cast Iron
18	1	099295	Ground Wire Assy	
19	1	068984	◇† Gasket	
20	1	089120	Volute	Cast Iron
21	4	1-172-1	Hex Hd Cap Screw , SEV511-521	5/16-18 x 3.25" Stainless
	4	1-299-1	Hex Hd Cap Screw , SE411-421	5/16-18 x 2.75" Stainless
22	1	027271	Handle	
23	58 oz.	029034	Oil	
24	1	015000	† Pipe Plug	
25	A/R	----	Loctite	#RC609
26	A/R	----	Loctite	#242
27	1	----	Bearing Sleeve	PART OF MOTOR ASSEMBLY

(*) Included with item 9

(**) Cast Iron Impeller replaces Zytel Impeller 089116, 5/02.

(‡) Units with a Build Code date before 11/01 may use capacitor Part Number 070964 or 035864

SERIES: SE & SEV

29	1		Float Switch w/Plug, Mechanical	Series: A
		101758	15FT	
		101758XA	20FT	
		101758XC	30FT	
		101758XF	50FT	
29	1		Float Switch High Temp w/Plug	Series: HTA
		090269	15FT	
		090269XB	25FT	
		090269XC	30FT	
		090269XF	50FT	
29	1	099262	Float Switch, Mechanical	Series: AU
29	1	090622	Float Switch High Temp, Mech.	Series: HTAU

ITEMS 29A thru 35 ARE FOR MODELS: AU, USED WITH 099262 FLOAT.

29a	1	051448	Gland Nut	1-16
29b	1	051449	Friction Ring	
30	1	090516	Cord Clip	
31	1	20-12-1	Lockwasher	#10 Stainless
32	1	2-88-1	Rd Hd Screw	10-32 x 3/8 Lg. Stainless
35	A/R	----	Permatex Sealant #2C	

ITEMS 29A thru 35 ARE FOR MODELS: HTAU, USED WITH 090622 FLOAT.

29a	1	051762	Gland Nut	1-16 Stainless
29b	2	089121	Friction Ring	
29c	1	090103	Grommet	
30	1	090516	Cord Clip	
31	1	20-12-1	Lockwasher	#10 Stainless
32	1	2-88-1	Rd Hd Screw	10-32 x 3/8 Lg. Stainless
35	A/R	----	Permatex Sealant #2C	
40	A/R	----	Loctite, #242	
41	1	100829	Vertical Float Switch	Series: VF
42	1	100547	Mounting Bracket	
43	2	021337	Pan Hd, Self-Taping Screw	10-16, Stainless
45	2	See BOM	Connector	Hi-Temp Only
	3	See BOM	Connector	(HTAU) Hi-Temp Only
46	2	022229	Shrink Tube	Hi-Temp Only
	3	022229	Shrink Tube	(HTAU) Hi-Temp Only
47	1	096726	Adapter Plate	SEV, Only
48	A/R	098679	Shim, .030" Thk	For use w/ 089369 Only

SERIES: SE & SEV

TABLE 2 - MOTOR and HOUSING

PUMP MODEL	MOTOR HOUSING (Item #14)	MOTOR SLEEVE (Item #1)
SE411	093065	102260
SE411A	093065	102260
SE411VF	093065	102260
SE421	093065	098835
SE411HT	093065	098838
SE411HTA	093065	098838
SE411HTAU	093066	098838
SE421HT	093065	098835
SE421HTAU	093066	098835
SE511	093065	098838
SE511A	093065	098838
SE511AU	093066	098838
SE511VF	093065	098838
SE521	093065	098835
SE521AU	093066	098835
SEV511	093065	098838
SEV511A	093065	098838
SEV511AU	093066	098838
SEV511VF	093065	098838
SEV521	093065	098835
SEV521AU	093066	098835

TABLE 3 - POWER CORDS SETS

MODELS/ LENGTH	ITEM #9 SE411 Series	ITEM #9 SE511, SEV511	ITEM #9 SE421 Series & SE521, SEV521	ITEM #9 SE411HT Series	ITEM #9 SE421HT Series
15 FT (5m) STD	138154	099260	099261	100502	100525
20 Ft. (6m)	138154XA	099260XA	099261XA	-	-
25 Ft. (7.5m)	-	-	-	100502XB	100525XB
30 Ft. (9m)	138154XC	099260XC	099261XC	-	-
50 Ft. (15m)	138154XF	099260XF	099261XF	100502XF	100525XF

SERIES: BP314, BP324, BP314HT & BP324HT

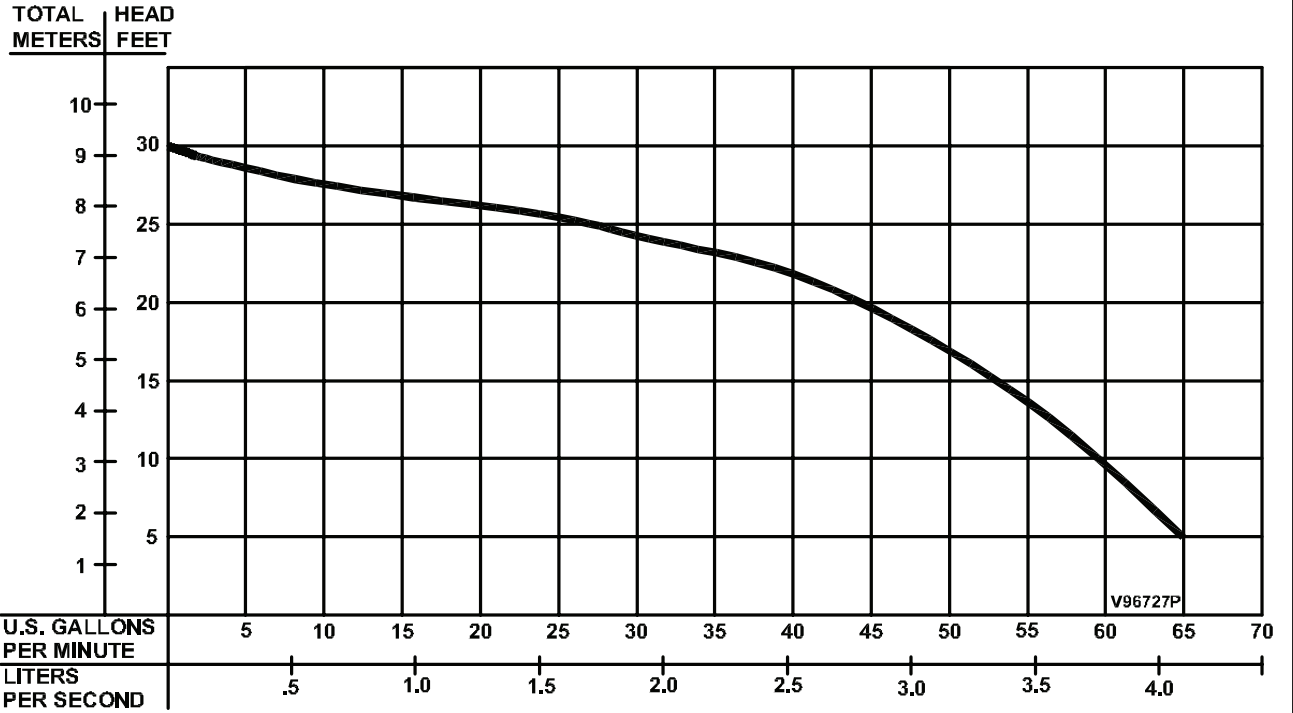

SERIES: SE511, SE521, SEV511 & SEV521

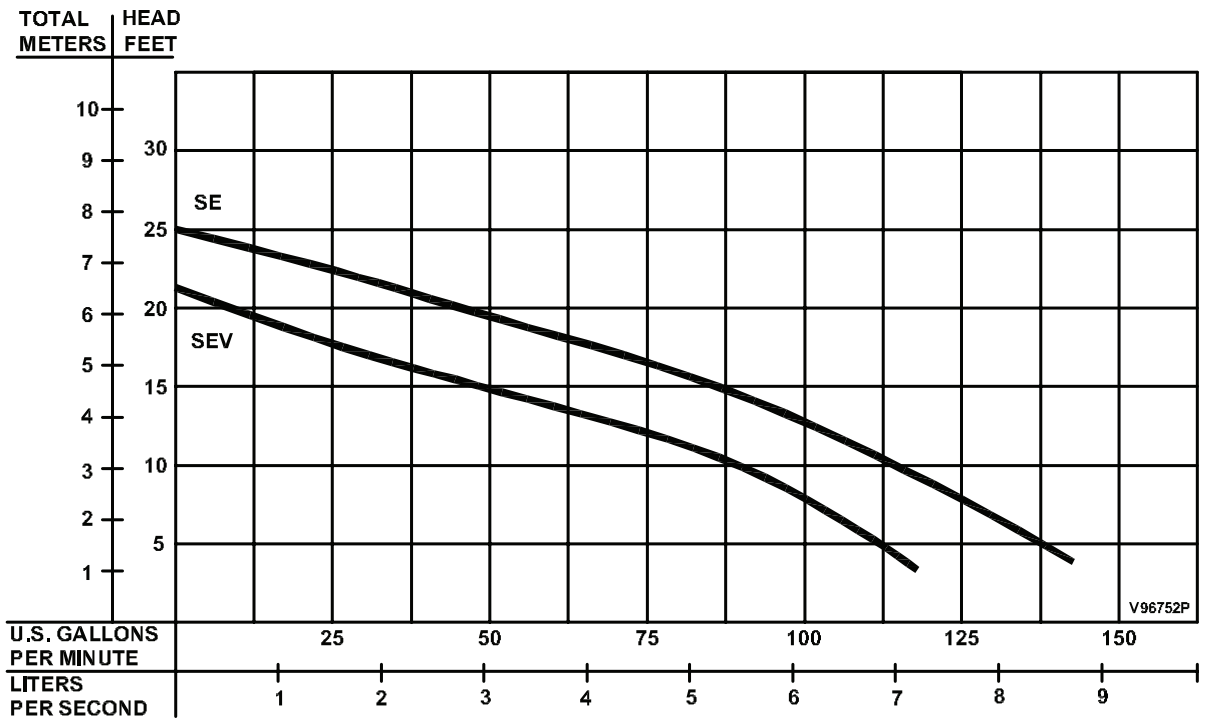

Testing is performed with water specific gravity of 1.0 @ 68°F (20°C), other fluids may vary performance

SERIES: SE411 & SE421

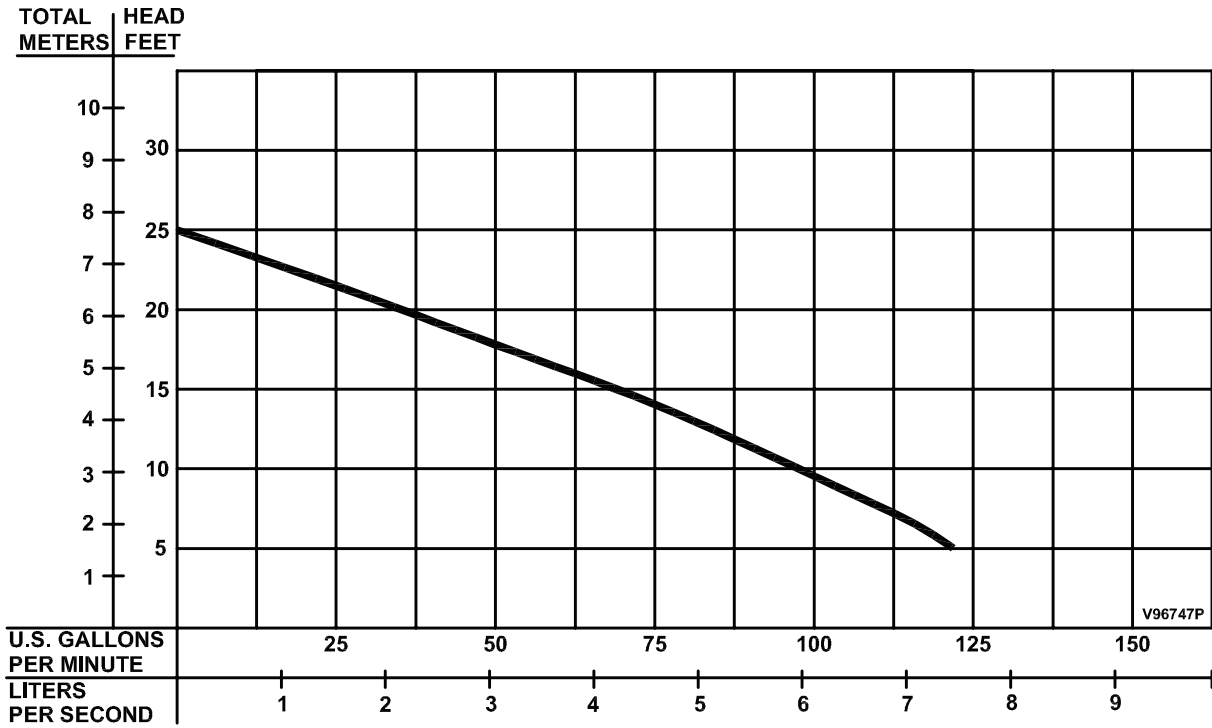

SERIES: SE411HT & SE421HT

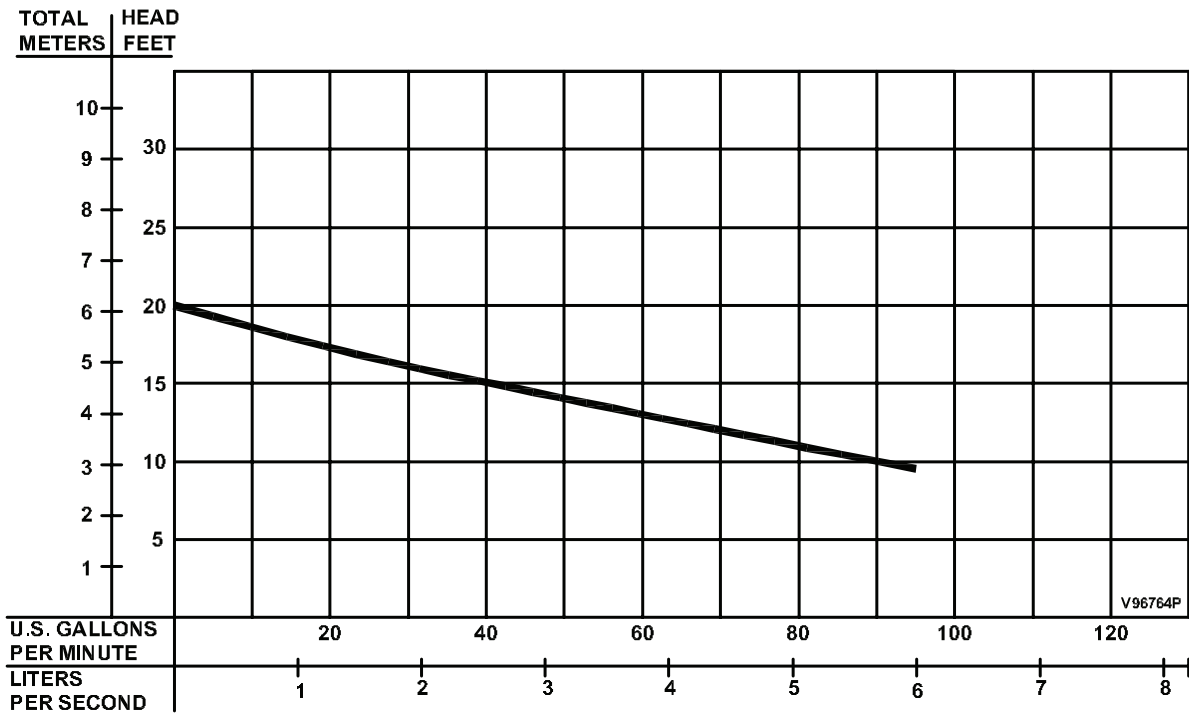

Testing is performed with water specific gravity of 1.0 @ 68°F (20°C), other fluids may vary performance

IMPORTANT!
WARRANTY REGISTRATION

Your product is covered by a warranty:
www.cranepumps.com/downloadables/CATALOGS_OIPMs/Warranty/24MonthWarranty.pdf

If you have a claim under the provisions of the warranty, contact your local
Crane Pumps & Systems, Inc. Distributor.

RETURNED GOODS

**RETURN OF MERCHANDISE REQUIRES A "RETURNED GOODS AUTHORIZATION".
CONTACT YOUR LOCAL CRANE PUMPS & SYSTEMS, INC. DISTRIBUTOR.**



**Products Returned Must Be Cleaned, Sanitized,
Or Decontaminated As Necessary Prior To Shipment,
To Insure That Employees Will Not Be Exposed To Health
Hazards In Handling Said Material. All Applicable Laws
And Regulations Shall Apply.**