

T200 PRO SERIES

MEDIUM PRESSURE

Maximum Flow Rate: 94 gpm (355 l/min) 3222 BPD
 Maximum Pressure: 3500 psi (241 bar)



WANNER™

HYDRA-CELL® PRO
 SEAL-LESS PUMP TECHNOLOGIES

AVAILABLE
 TO MEET



UK
 CA CE

*T200 Pro Series Medium Pressure model with
 Nickel Aluminum Bronze (NAB) pump head.*

A higher standard of pump performance and energy efficiency.

- Integrates **Wanner Hydra-Cell® Pro** seal-less pump technologies for the highest levels of volumetric and energy efficiencies across a full rpm range.
- Patented ADPC (Advanced Diaphragm Position Control) and hydraulic oil management system protect diaphragms under closed or restricted inlet conditions.
- Can run dry indefinitely without damage to the pump.
- Pumped fluid is 100% contained – zero environmental impact, no ground contamination, no volatile emissions.
- Seal-less design eliminates leaks, hazards, and the expense associated with seals and plunger packing.
- Exceeds API 675 standards for accuracy, linearity, and repeatability.
- Reliably handles a wide range of viscosities and shear sensitivities, corrosive fluids, abrasives, slurries and particulates.
- Reduced ownership costs – acquisition, operation, service, maintenance and energy use.



WANNER™

PumpSupplyInc.com

WANNER ENGINEERING, INC.

IL - (847) 841-7867

HYDRA-CELL.COM

MN - (651) 758-7867

T200 Pro Medium Pressure | Performance

Capacities

Model	Max. Input rpm	Plunger Dia.		Max. Flow Capacities			Max. Pressure Ratings			
		inches	mm	gpm	l/min	BPD	Discharge		Inlet	
							psi	bar	psi	bar
T200K	400	2.250	57	94	355	3222	3000	207	500	34
T200M	400	2.125	54	84	318	2880	3500	241	500	34

Consult factory when operating below 40 rpm

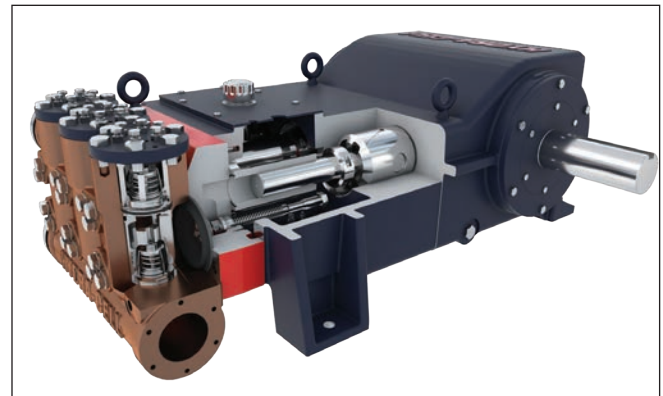
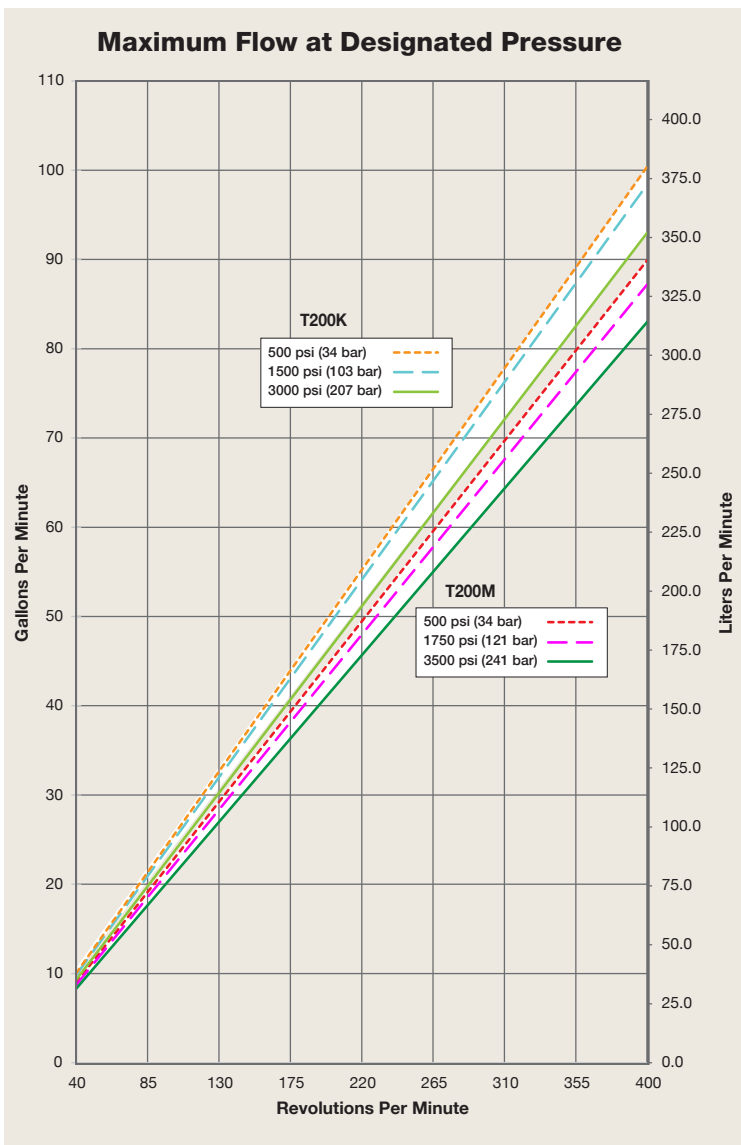

T200 Pro Series pumps feature the Hydra-Cell seal-less design, eliminating clean-up costs from leaking seals or packing and protecting operators from dangerous fluids such as those containing hydrogen sulfide.

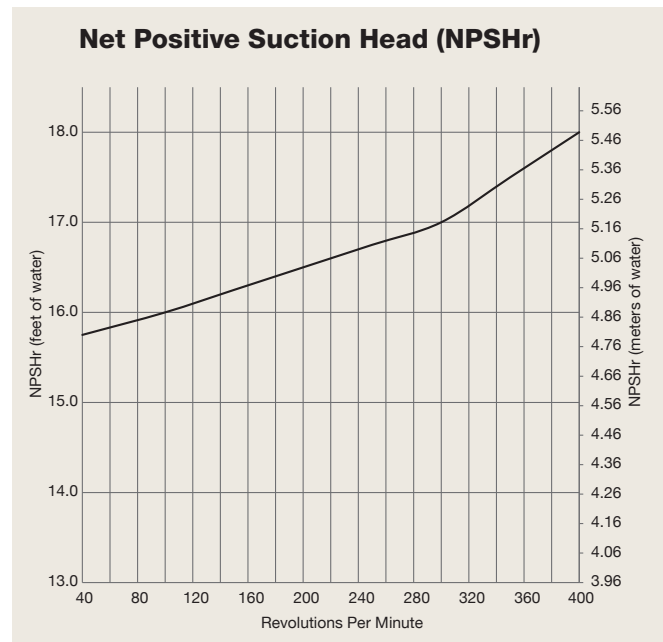

Due to the Wanner Engineering Continuous Improvement Program, specifications and other data are subject to change.

T200 Pro Medium Pressure | Specifications

Flow Capacities

Model	Pressure psi (bar)	rpm	gpm	l/min	BPD
T200K	3000 (207)	400	94	355	3222
T200M	3500 (241)	400	84	318	2880

Delivery

	Pressure psi (bar)	gal/rev	liters/rev
T200K	500 (34)	0.250	0.946
	1500 (103)	0.244	0.925
	3000 (207)	0.235	0.889
T200M	500 (34)	0.225	0.852
	1750 (121)	0.219	0.831
	3500 (241)	0.211	0.799

rpm

Maximum:	400
Minimum:	40

Consult factory for speeds less than 40 rpm.

Maximum Discharge Pressure

Metallic Heads:	T200K	3000 psi (207 bar)
	T200M	3500 psi (241 bar)

Maximum Inlet Pressure

500 psi (34 bar)

Operating Temperature

Maximum:	180°F (82.2°C)
Minimum:	40°F (4.4°C)

Consult factory for temperatures outside this range.

Maximum Solids Size

800 microns

Input Shaft

Right Side

Inlet Ports

Weld-On: 4" / SCH. 40
4" NPT, 4" Class 300 RF ANSI Flange

Discharge Ports

Weld-On: 2" / SCH. 160
2" NPT, 2" Class 2500 RTJ ANSI Flange

Plunger Stroke Length

5 inch (127 mm)

Shaft Diameter

4 inch (101.6 mm)

Shaft Rotation

Uni-directional (See rotation arrow.)

Oil Capacity

80 US quarts (75.7 liters) - blank back cover
See page 5 for oil selection and specification.

Pump Weight

3000 lbs. (1361 kg)

Fluid End Materials

Manifold:	Nickel Aluminum Bronze (NAB) Duplex Alloy 2205 Stainless Steel CF3M (316L) Stainless Steel Hastelloy CX2MW
Diaphragm/Elastomers:	FKM Buna-N
Diaphragm Follower Screw:	316 Stainless Steel Duplex Alloy 2205 Stainless Steel Hastelloy C
Valve Spring Retainer/Guide:	Hastelloy C / PVDF
Check Valve Spring:	Elgiloy Hastelloy C
Valve Disc/Seat:	17-4 Stainless Steel Nitronic 50 Hastelloy C
Inlet/Outlet Valve Retainer:	316 Stainless Steel Duplex Alloy 2205 Stainless Steel Hastelloy C

Power End Materials

Crankshaft:	Forged Q&T Alloy Steel
Connecting Rods:	Ductile Iron
Crossheads:	Ductile Iron
Crankcase:	Ductile Iron
Bearings:	Spherical Roller (main) Steel-backed Tri-metal (crankpin) Bronze (wristpin)



Calculating Required Horsepower (kW)*

$$\frac{\text{gpm} \times \text{psi}}{1,460} = \text{electric motor hp}^*$$

$$\frac{\text{lpm} \times \text{bar}}{511} = \text{electric motor kW}^*$$

* hp (kW) is required application power.

Attention!

When sizing motors with variable frequency drives (VFD): It is very important to select a motor and a VFD rated for constant torque inverter duty service and that the motor is rated to meet the torque requirements of the pump throughout desired speed range.

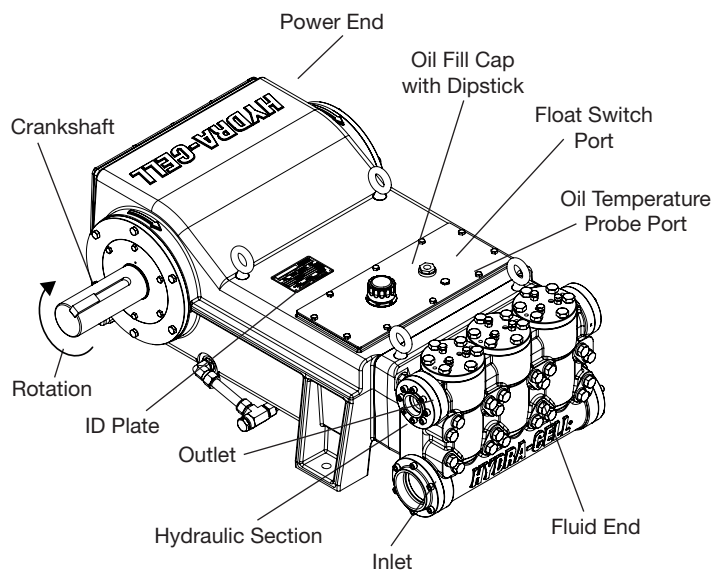

Due to the Wanner Engineering Continuous Improvement Program, specifications and other data are subject to change.

T200 Pro Medium Pressure | Drawings

Threaded Version inches (mm)



Side View

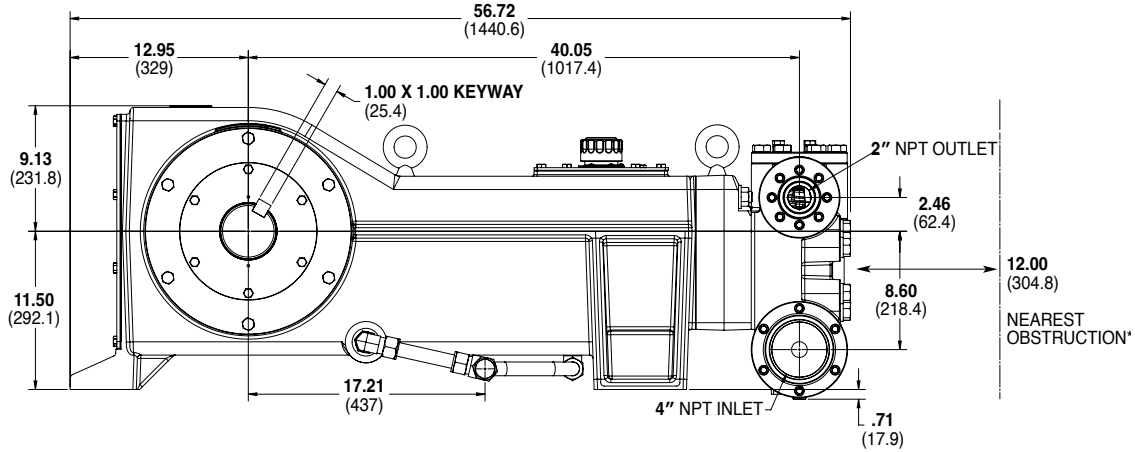

*Contact factory for obstruction distances closer than 12 inches (304.8 mm).

Illinois Location:

(847) 841-7867

860 Church Rd Elgin, IL 60123

Minnesota Location:

(651) 758-7867

330 Mill Bay South Suite 1511 Afton, MN 55001

PumpSupplyInc.com

Front View

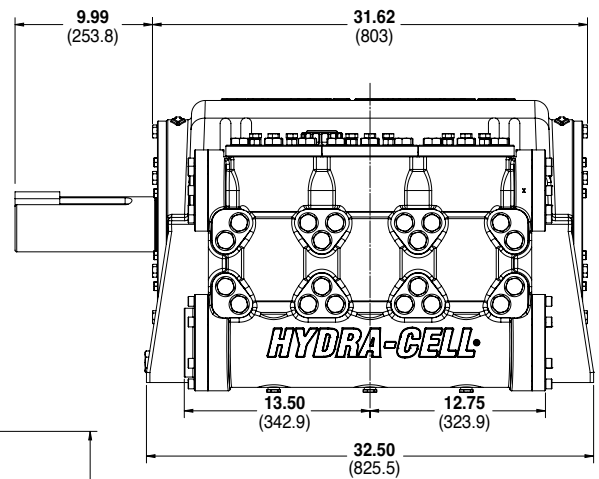

Bottom View

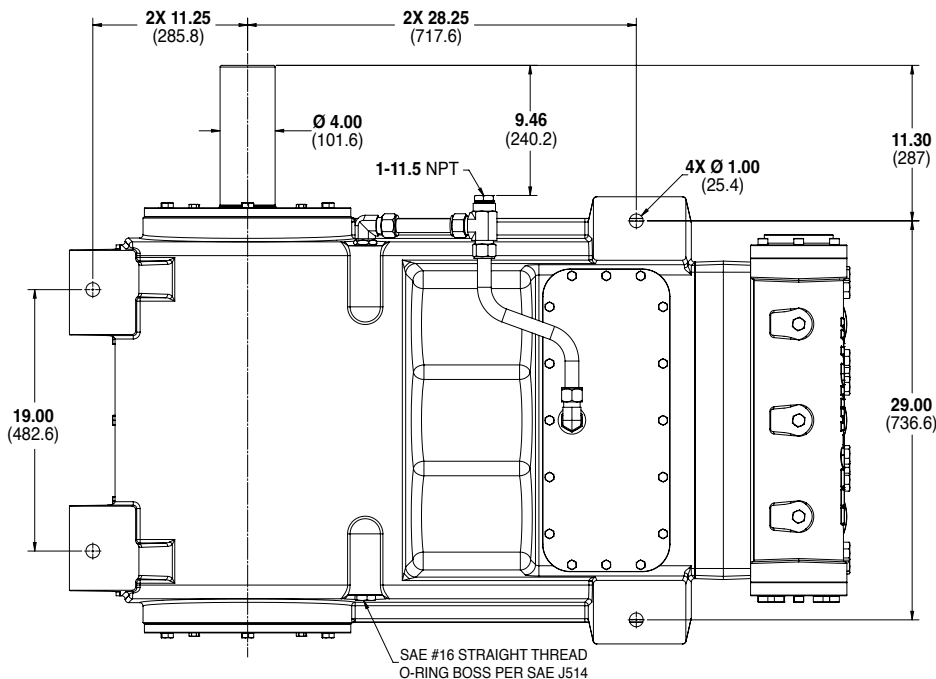

Note: Dimensions are for reference only. Contact factory for certified drawings.

T200 Pro Medium Pressure | How to Order

Ordering Information

A complete T200 Pro Series Medium Pressure Model Number contains 14 digits including 9 customer-specified design and materials options, for example: T200KADTHFETAC.

1	2	3	4	5	6	7	8	9	10	11	12	13	14
T	2	0	0								T		

Medium Pressure

Digit	Order Code	Description
1-4	T200	Pump Configuration Shaft-driven
5	K	Performance Max. 94 gpm (355 l/min) 3222 BPD @ 3000 psi (207 bar)
	M	Max. 84 gpm (318 l/min) 2880 BPD @ 3500 psi (241 bar)
6	A	Pump Head Version NPT Ports, Steel
	C	Weld Neck, Steel
	D	Weld Neck, 316L Stainless Steel
	E	Weld Neck, Hastelloy C
	F	Weld Neck, Duplex Alloy 2205 Stainless Steel
	G	ANSI Flanged Ports, Duplex Alloy 2205 Stainless Steel
	T	ANSI Flanged Ports, Hastelloy C
7	D	Pump Head Material Nickel Aluminum Bronze (NAB)
	G	Duplex Alloy 2205 Stainless Steel
	S	CF3M (316L) Stainless Steel
	T	Hastelloy CX2MW
8	G	Diaphragm & O-ring Material FKM
	T	Buna-N
9	H	Valve Seat Material 17-4 Stainless Steel
	N	Nitronic 50
	T	Hastelloy C
10	F	Valve Material 17-4 Stainless Steel
	N	Nitronic 50
	T	Hastelloy C

Digit	Order Code	Description
11	E	Valve Springs Elgiloy
	T	Hastelloy C
12	T	Valve Spring Retainers / Valve Guide Hastelloy C / PVDF
13	A	Hydra-Oil 10W30 standard-duty oil
	B	40-wt. oil
	H	15W50 high-temp severe-duty synthetic oil
14	C	Oil Level Monitoring Float switch, normally closed (recommended)
	O	Float Switch, normally open
	S	Float switch, Class I, Div. 1, Groups A, B, C, D, normally closed
	T	Float switch, Class I, Div. 1, Groups A, B, C, D, normally open
	Y	No switch, flat back cover



WANNER™ HYDRA-CELL® PRO



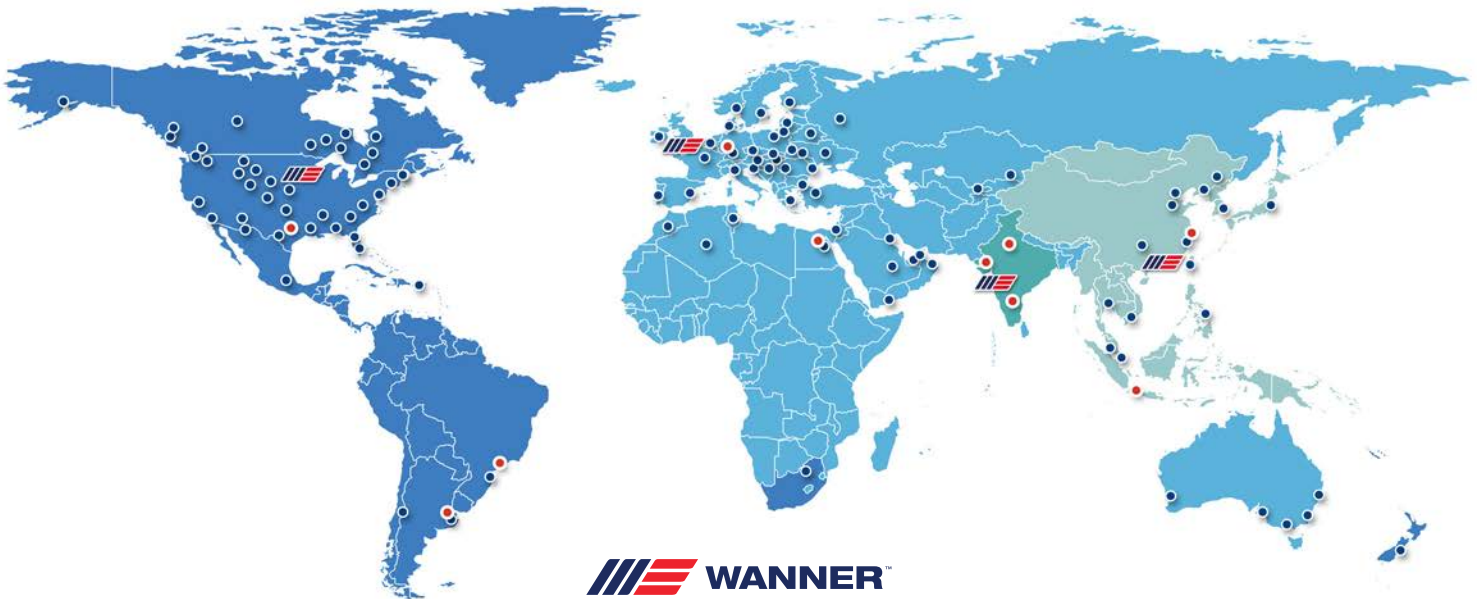

SEAL-LESS PUMP TECHNOLOGIES

Partners in over 70 countries





WANNER™
Global Sales and Technical Support



Americas

-  Minneapolis, Minnesota USA
-  Wichita Falls, Texas USA
-  São Paulo, Brazil
-  Buenos Aires, Argentina





EMEA | Australia

-  Hampshire, United Kingdom
-  Cairo, Egypt
-  Remagen, Germany

Asia | Pacific

-  Kowloon, Hong Kong
-  Shanghai, China
-  Jakarta, Indonesia

India

-  Mumbai, India
-  New Delhi
-  Bangalore
-  Gujarat

Wanner worldwide

GLOBAL SALES & TECHNICAL SUPPORT



Illinois Location:

(847) 841-7867

860 Church Rd Elgin, IL 60123

Minnesota Location:

(651) 758-7867

330 Mill Bay South Suite 1511 Afton, MN 55001

PumpSupplyInc.com

