



PUMP SUPPLY
INCORPORATED

860 Church Road
Elgin, Illinois 60123
847-841-PUMP (7867)

330 Mill Bay South, Suite 1511
Afton, Minnesota 55001
(651)758-PUMP (7867)

sales@pumpsupplyinc.com

www.pumpsupplyinc.com



mRoy™ MacRoy™ Centrac™ Milroyal™
Primeroyal™ Megaroyal™



Milton Roy® Metering Pumps: Complete line of hydraulically, mechanically, and pneumatically actuated diaphragm and packed plunger metering pumps, and peristaltic pumps. Pumps are available in cast iron, stainless steel, PVC, Kynar (PVDF), and various alloys. Double diaphragm with rupture detection and metallic diaphragm designs available for critical or extreme services. Capacities from 0.0081 GPH to over 25,593 GPH. Pressures up to 20,000+ PSIG. Multiplex arrangements available. API 675 compliant pumps are available across the range of Milton Roy pumps.



Ebara® Centrifugal Pumps: Horizontal end-suction, vertical multistage, submersible, and self-priming centrifugal pumps in stainless steel and cast iron construction. Horizontal pumps to 30HP, vertical pumps to 60HP, submersible pumps to 500HP. Quick disconnect and slide rail systems available, including adapters for many major manufacturers' rail systems.



STAN-COR *Hydra-Cell* VECTOR



Wanner® Hydra-Cell™ High Pressure Pumps: Hydraulically actuated, positive displacement diaphragm pumps, with low-pulsation output. Kel-Cell™ models can run dry or run with a blocked suction without damage. Pumps can handle abrasive slurry fluids. Capacities up to 157 GPM and pressures up to 5000 PSIG.

Stan-Cor® Nonmetallic Pumps: ANSI-dimensional centrifugal pumps in PVDF and PTFE non-metallic construction.



ARO® Air Operated Pumps and Air System Components: Air operated diaphragm and piston type fluid handling pumps in metallic and non-metallic construction, handling a wide variety of viscosities & fluids. Diaphragm pumps available in sizes from 1/4" to 3", for chemical transfer, dosing, and general industrial service. Piston pumps for finishing equipment, sealants, adhesives, coatings, greases, and general transfer. Pumps are available with follower plates, ram assemblies, and cart mounts for 5-gallon and 55-gallon containers. ARO air system components include filters, regulators, lubricators, solenoid valves, and manifolds. ARO fluid pressure regulators and dispensing guns are available.

SEEPEX.

ALL THINGS FLOW

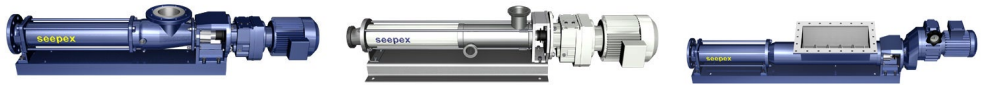

Seepex® Progressive Cavity Pumps: Progressive cavity pumps in a variety of materials for almost any application, including slurries, high-viscosity (up to 1,000,000 cP), metering, and 3A-approved sanitary service. Pumps are available with a range of engineered options, including inlet feed augers, feed hoppers, and macerators. SCT™ Smart Conveying Technology pumps feature a split two-piece stator design that is adjustable, as well as a removable two-piece rotor. SCT™ allows for stator retensioning and smaller space requirements for stator removal.



Albin® Pumps: Peristaltic (hose) pumps for a range of applications, including metering, chemical transfer, lime slurry, cement and concrete industries, mining, filter press feed, high viscosity, and fragile fluids. Sizes to 660 GPM, 6” ports, and self-priming to 31’, with dry-run capability. Hoses available in natural rubber, NBR, food-grade natural rubber, food-grade NBR, EPDM, Hypalon, and Viton. Albin® hoses are available to fit other major manufacturers’ pumps.



USA



Gorman-Rupp® Pumps: Rotary gear, self-priming and standard centrifugal pumps, submersible pumps, and pump packages for a wide range of fluids, including chemical, abrasive, viscous, and solids-containing applications. Gear pumps to 6” sizes, and centrifugal pumps to 12”. Complete pump packages with engine drive, and priming assist are available.

CRANE PUMPS & SYSTEMS



Crane® Centrifugal Pumps: Centrifugal pumps in cast iron construction for a wide variety of applications. Horizontal end suction, horizontal and vertical split case, vertical in-line, vertical sump pump, submersible, and chopper designs available. Horizontal end-suction pumps are interchangeable with many popular designs. Flows to 7000 GPM and heads to 800’.

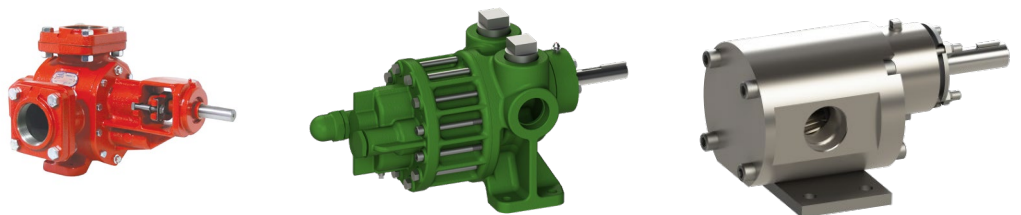

Roper® Gear Pumps: Rotary gear pumps for a wide range of fluids, in cast iron and stainless steel construction, up to 8” port sizes. Applications include bulk liquid handling, lubrication, oilfield service, chemical transfer, and specialty pumps. Roper® ROC stainless steel gear pumps are available in sealed and sealless magnetic-drive configurations.

VERTIFLO PUMP COMPANY
The Industrial Pump Specialists



Vertiflo® Pumps: Vertical and horizontal centrifugal pumps in varying sizes and pit depths, for wastewater and process applications. Single-channel, semi-open, and vortex impellers are available for solids-handling applications. Pumps are available in cast iron, 316 stainless steel, and alloys, with a range of mounting plate and piping arrangements to fit existing installations.

CENTENNIAL PUMPS
by Wilfley®

WILFLEY®
HEAVY DUTY
CENTRIFUGAL PUMPS



Centennial® by Wilfley® ANSI Pumps: ANSI-standard centrifugal pumps in carbon steel and CD4MCu construction, in ANSI Group 1 and Group 2 sizes. Price-competitive ANSI-standard pumps for a variety of process applications.

Wilfley® Pumps: Slurry and chemical pumps with sealless and sealed designs, available in a wide range of corrosion-resistant and hard-metal alloy materials. Wilfley pumps have been in the toughest services for over 100 years.

FYBROC
Fiberglass Reinforced Pumps



Fybroc® Pumps: Corrosion-resistant fiberglass centrifugal pumps for acids, brines, caustics, bleaches, solvents, seawater, aquariums, and waste liquids. Horizontal and vertical pumps, sealed and magnetic-drive options, and multiple fiberglass material options for a range of corrosive applications.

Invertek Drives.com
Lenze
AC Tech

Drives and Control Panels: Drives from Invertek® and Lenze ACTech, as well as custom control panels with drives, HMI, enclosures, to meet customer specifications.



Electric motors from Baldor/ABB®, WEG®, Leeson®, and Marathon®, including standard, washdown duty, severe-duty, and explosion-proof designs.

Lutz JESCO USA
Lutz Pumps Inc.

Solenoid-driven, stepper motor, and electric motor driven metering pumps. Drum, tote, and mixing pumps in metallic and non-metallic designs, with electric or air motor drives.



Self-priming, trash, and hot oil pumps, available in cast iron, bronze, and stainless steel construction. Pumps to 4" discharge and 30 HP.

MTH Pumps

Regenerative turbine pumps for high-pressure applications and engineered canned motor pumps.



Pulsation dampeners, surge suppressors, and gauge isolators. Available in a range of materials and configurations, including high pressure and sanitary construction.

MARCH PUMPS

Magnetic drive sealless centrifugal pumps in non-metallic or stainless steel construction. Condensate and circulation pumps.



Non-metallic, magnetically driven, sealless centrifugal pumps, vertical immersion pumps, and drum pumps. Available in a variety of materials.

GRIFFCO

Back pressure and pressure relief valves from ¼" to 4". Calibration columns, injection valves, pulsation dampeners, and gauge guards.



Solenoid-driven diaphragm and peristaltic metering pumps, non-metallic and stainless steel. Manual or external control. Flows to 25gph and pressures to 300psi.

DEKKER
VACUUM TECHNOLOGIES, INC.

Vacuum pumps and compressors in liquid ring and rotary vane designs. Bare pumps and complete central systems available.



Custom-made hoses available for a range of applications, including water, air, chemicals, and high-pressure fluids.



PUMP SUPPLY
INCORPORATED



INSTALLATION TECHNOLOGIES



Machine Mounting: Unisorb® is the leading specialist in engineering and manufacturing products and systems to ensure proper machinery installation. Unisorb® offers a full line of machine mounts, mounting pads, V-1 grout, V-100 epoxy grout, capsule anchor systems, vector bolts, isolation block materials, and engineered inertia block applications. Unisorb®'s experienced staff of designers, application engineers, and field engineers assures optimum performance of mounted equipment.



Ingersoll Rand



ASG
Assembly • Industrial • Precision Fastening



Tools for Assembly, Finishing, and Fabrication: Ingersoll-Rand® electric screwdrivers, air screwdrivers and nutrunners, and cordless fastening systems; Sioux Tools® torque-control screwdrivers, routers, drills, grinders, and sanders; ASG Tools® precision pneumatic screwdrivers.



Torque Testing for Assembly: Advanced Witness® torque testing equipment, including quick tool check (QC), single- and multiple-transducer testing units, handheld controller and testing units, bench mount transducers, and high-torque test stands. Heavy-duty aluminum and steel construction and in-house manufacturing and design ensures durability.



Automatic Fastening Systems
Ergonomic Power Tool Accessories



Screw Feeding for Assembly: D-G Industries® automatic fastening systems to feed screws, nuts, drive screws, terminals, and specialty fasteners, with optional fastener presence and torque verification equipment available. Smooth, well-balanced driver mechanisms requiring low exertion forces, with ergonomic grips and accessories are available to reduce vibration, torque reaction, and hyperextension or flexion of the wrist. Optional Screw-Lok Jaw System™ holds fasteners rigidly in the driver mechanism to enable operator to align parts.



Hose Reels: Coxreels® manufactures heavy-duty, professional-grade hose, cord, and cable reels of the highest quality, including spring retractable, hand crank, and motorized reels. EZ-Coil® Safety Series spring retractable reels provide controlled rewind. Reelcraft® hose reel designs have served the industrial and automotive markets for over fifty years. Reelcraft® quality reels are serving every conceivable application from Alaska to the Middle East, and withstand rigid military tests, including shock and impact of military parachute drops.

Service and Repairs

Pump Supply Incorporated services a range of centrifugal and positive displacement pumps at our full-service repair shop in Elgin, Illinois.

Services include pump pick-up at a customer's facility, inspection, repair, performance and equipment upgrades, and performance testing.

Pump Supply Incorporated is a factory-certified repair center for Milton Roy® metering pumps, ARO®, Wanner Hydra-Cell™, Ebara®, Seepex®, and Albin® pumps. We repair positive displacement and centrifugal pumps. We can also coordinate factory repairs with our manufacturers.





Systems and Fabrication Services

Pump Supply Incorporated offers custom turnkey pump systems built in-house to meet your specifications, whether simple or complex. All systems are fully tested prior to shipment. CAD drawings and full documentation services are available.

Typical applications include:

- Chemical injection systems
 - Process chemical feed
 - Corrosion and scale inhibitors
 - pH control
- Chemical transfer
- Water pressure boost
- Machine tool coolant
- Cooling tower packages
- Boiler feed systems
- Polymer make-up and feed
- Centralized pressure wash



Food additive package with Milton Roy® mRoy metering pumps, control panel, and tanks mounted on a stainless steel cart



Acetic acid metering pump skid with Milton Roy® Milroyal metering pumps, socket-welded piping, extended valve stems for heat tracing and insulation, and fabricated steel base plate

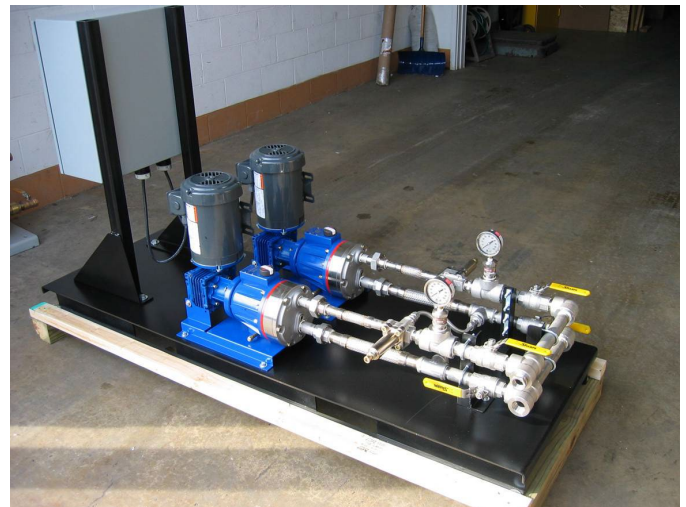

High-pressure slurry pumping system with Wanner® Hydra-Cell™ high-pressure diaphragm pumps, relief valves, and control panel. Narrow-profile system is designed to accommodate customer space and entry door requirements

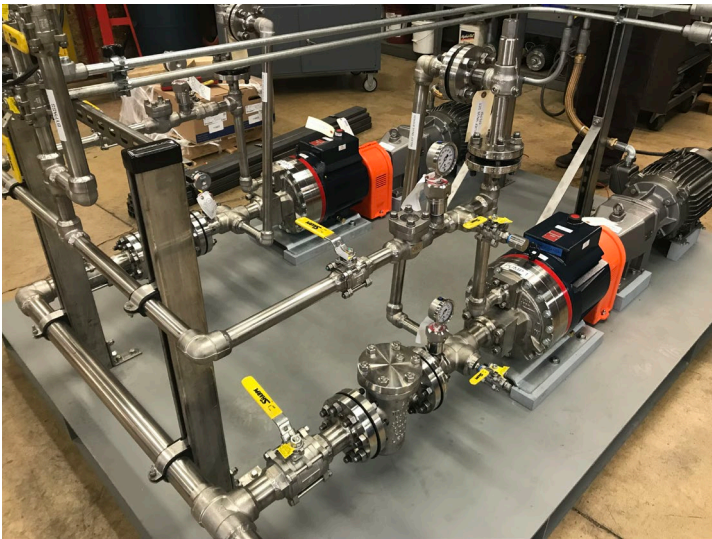

Chemical additive skid with two Wanner® Hydra-Cell™ D35 pumps, socket-welded piping, gear reducers, explosion-proof motors, and an explosion-proof control panel with variable-frequency drives and Z-purge

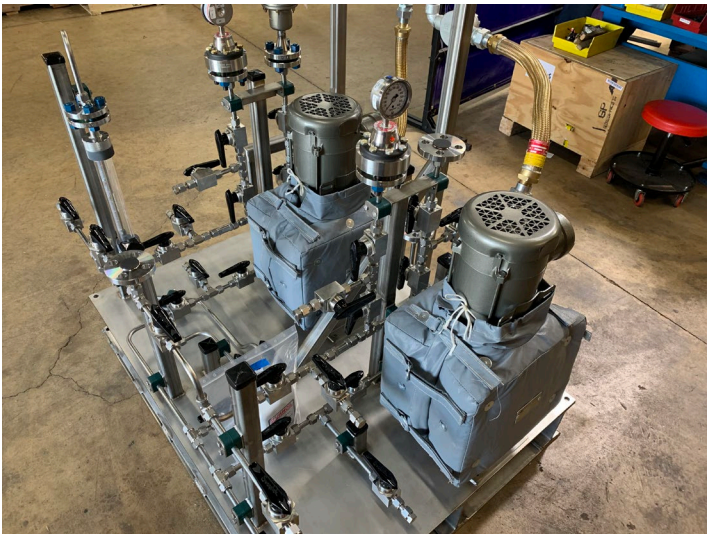

Chemical additive skid with two Milton Roy® mRoy™ series pumps, stainless steel tubing, explosion-proof motors and control panel, and custom-fit insulating pump jackets



Water reclamation system with two Ebara® EVMSU vertical multistage pumps, fabricated stainless steel tank with level controls, control panel with disconnects, mounted to a fabricated steel base plate to fit through a customer-specified door entrance



Sump pump package with two Ebara® Dominator stainless steel submersible sewage pumps, fabricated steel mounting/lifting plate, and float switches for drop-in installation in a drainage sump

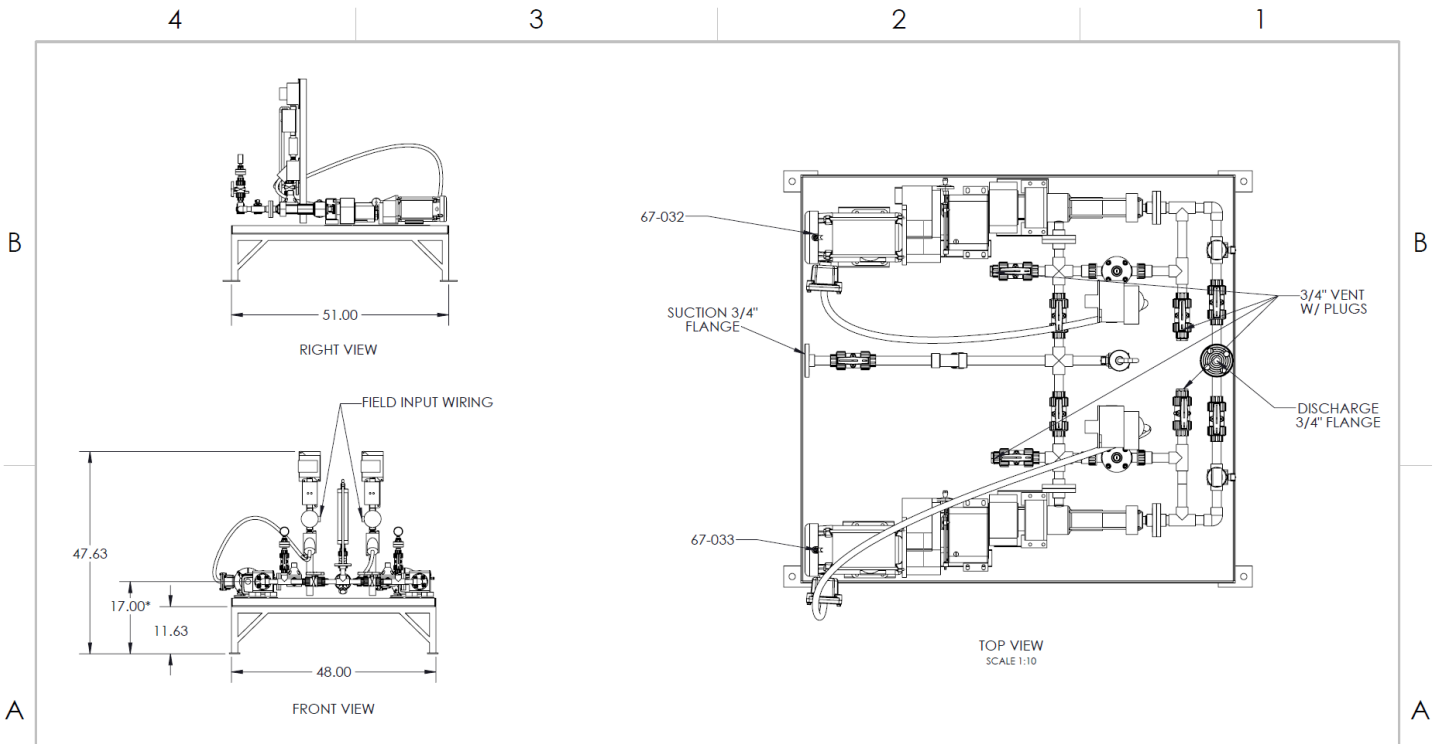

REV	DESCRIPTION	DATE	DWN	CHKD	APVD	ECN
00	APPROVAL	1/10/24	RV			
01	ADDED CIRCUIT INTERRUPTER	2/15/24	R.V			
02	ADDED SUCTION HEIGHT DIMENSION	2/21/24	R.V			
03	FRAME AND BOM MODIFICATIONS	2/26/24	R.V	APS		
04	CHANGED CENTERLINE SUCTION DIM.	3/28/24	R.V	APS		
05	CHANGED MOTOR TAGS	4/17/24	R.V	APS		

PUMP SUPPLY INCORPORATED
860 CHURCH RD, ELGIN IL 847-841-7867

SCALE: 1:20
DATE: 4/17/24

COOLING TOWER 8
DUPLX BLEACH SKID

DRAWN BY: R. VERASTEGUI
E-IGNER: A. SOCCORSO
DRAWING NUMBER: 92236-4

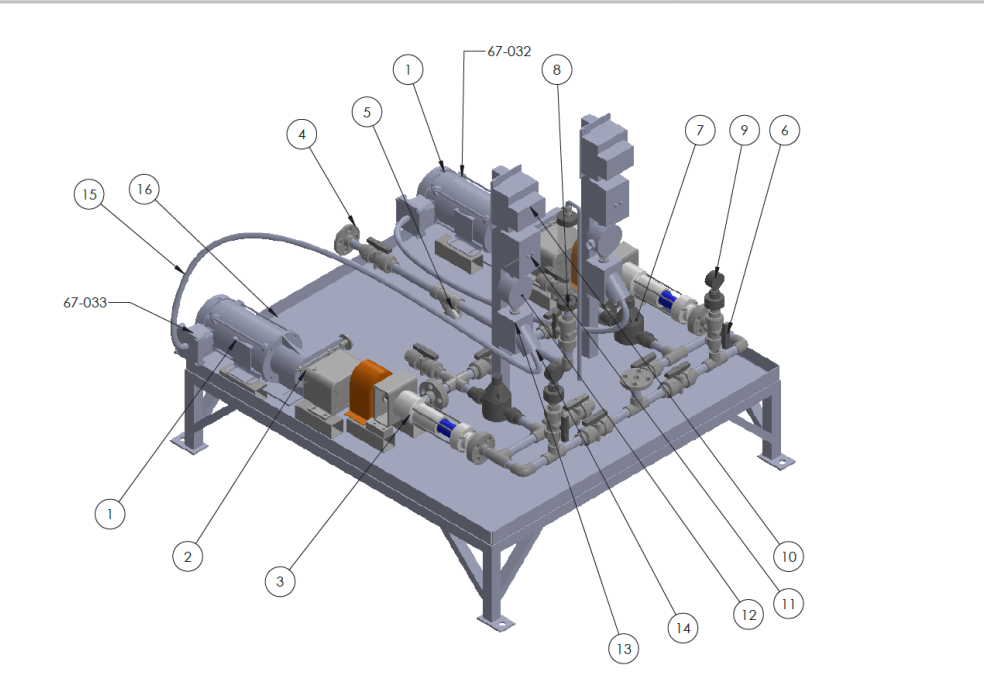

ITEM NUMBER	DESCRIPTION	QTY
1	BALDOR XL050542A 1/2HP, 1725RPM, 1PH, 60HZ, 56, 3424L, XPFC, F1, N.	2
2	CFY MOTOR ADAPTER KIT MODLE W/ Y2SC ZERO DRIVE W/ SCREW CONTROL	2
3	SEEPLEX MD006-12/BU-T4-T4-RO-GAE, CAPACITY 1,1-20.9, PRESSURE OPSI-174PSI, SPEED 25RPM-500RPM, SUCTION CASING MATERIAL CPVC	2
4	SUCTION FLANGE 3/4" CPVC	1
5	CPVC 3/4" Y-STRAINER	1
6	CPVC DOUBLE UNION BALL VALVES	9
7	GRIFFCO BPU075-CP BACK PRESSURE RELIEF VALVE	2
8	GRIFFCO CCG0500-CP 500mL CALIBRATION COLUMN	1
9	GGU050-CP-3-3 0-60 PSIG W/ GAUGE GAURD	2
10	TUMBLER SWICH 20A-120V 1-POLE 3/4" FEED APPLETON EDS-175 F1	2
11	APPLETON SEALED GROUND FAULT CIRCUIT INTERRUPTER, SINGLE GANG EDCS271	2
12	GRE 3/4"x3" TBE	2
13	PLUG END 20A-120V 2-POLE 3-WIRE APPLETON ECP-2023	2
14	RECEPTACLE 1-GANG 2-WIRE 3-POLE APPLETON EFS175-2023	2
15	5FT CABLE 600V OIL RESISTANT OUTDOOR RATED 12/3 TYPE 500W	2
16	FABRICATED SS BASE 48"x51" W/2" LIP AND 16' LEGS	1

REV	DESCRIPTION	DATE	DWN	CHKD	APVD	ECN
00	APPROVAL	1/10/24	RV			
01	ADDED CIRCUIT INTERRUPTER	2/15/24	R.V			
02	ADDED SUCTION HEIGHT DIMENSION	2/21/24	R.V			
03	FRAME AND BOM MODIFICATIONS	2/26/24	R.V	APS		
04	CHANGED CENTERLINE SUCTION DIM.	3/28/24	R.V	APS		
05	CHANGED MOTOR TAGS	4/17/24	R.V	APS		

PUMP SUPPLY INCORPORATED
860 CHURCH RD, ELGIN IL 847-841-7867

SCALE: 1:10
DATE: 4/17/24

COOLING TOWER 8
DUPLX BLEACH SKID

DRAWN BY: R. VERASTEGUI
E-IGNER: A. SOCCORSO
DRAWING NUMBER: 92236-4



860 Church Road
Elgin, Illinois 60123
(847) 841-PUMP (7867)
sales@pumpsupplyinc.com

330 Mill Bay South, Suite 1511
Afton, Minnesota 55001
(651) 758-PUMP (7867)
MNsales@pumpsupplyinc.com