

OPERATOR'S MANUAL

PP10A-XXX-XXX-A

INCLUDING: OPERATION, INSTALLATION AND MAINTENANCE

RELEASED: 5-25-18
 REVISED: 2-15-19
 (REV: C)

1" DRY POWDER DIAPHRAGM PUMP 1:1 RATIO (METALLIC)



READ THIS MANUAL CAREFULLY BEFORE INSTALLING, OPERATING OR SERVICING THIS EQUIPMENT.

It is the responsibility of the employer to place this information in the hands of the operator. Keep for future reference.

SERVICE KITS

Refer to Model Description Chart to match the pump material options.

- 7102** Valve Kit for repair of H254PS control valve.
- 104302** for repair of P39124-100 Filter / Regulator.
- 637401-XXX** for Fluid Section repair **with** seats (see page 6).
- 637401-XX** for Fluid Section repair **without** seats (see page 6).
- NOTE:** This kit also contains several air motor seals which will need to be replaced.
- 118597-2** Spool Kit for repair of A212PD 4-way alpha valve.
- 637397** for Air Section repair (see page 8).
- 637395-8** Major Air Valve assembly (see page 9).

PUMP DATA

- Models**..... see Model Description Chart for "-XXX"
- Pump Type**..... Metallic, Dry Powder, Diaphragm Pump
- Material**..... see Model Description Chart
- Specific Application** for pumping powders up to 50 lb. / ft³
- Weight**... PP10X-XA-X-XXX-A^{XXXX} 28.65 lbs (12.97 kgs)
 PP10X-XS-X-XXX-A^{XXXX} 46.2 lbs (20.9 kgs)
- Maximum Air Inlet Pressure** 50 psig (3.4 bar)
- Maximum Fluidizing Pressure** 100 psig (6.9 bar)
- Maximum Particle Size** 1/8" dia. (3.3 mm)
- Maximum Temperature Limits (diaphragm / ball / seat materials)**
 Santoprene® -40° to 225° F (-40° to 107° C)

- Dimensional Data**..... see page 11
- Mounting Dimension** . 4"x6.25" (101.6 mm x 158.8 mm)
- Noise Level** @ 70 psig, 60 cpm^①..... 80.6 dB(A)^②

① Tested with 94085 muffler assembly installed.
 ② The pump sound pressure levels published here have been updated to an Equivalent Continuous Sound Level (LA_{eq}) to meet the intent of ANSI S1.13-1971, CAGI-PNEUROP S5.1 using four microphone locations.

NOTICE: All possible options are shown in the chart, however, certain combinations may not be recommended. Consult a representative or the factory if you have questions concerning availability.



PP10A-XXX-XXX-A Powder Pump

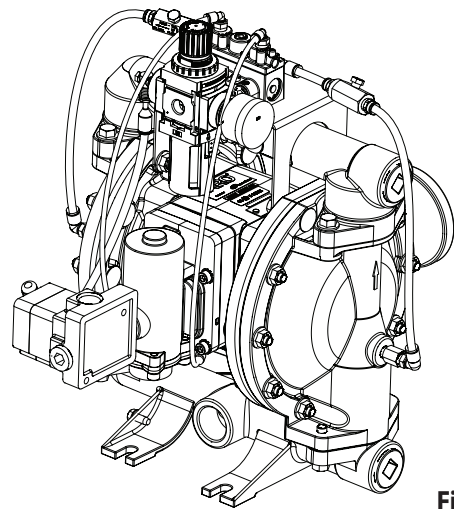

Figure 1

MODEL DESCRIPTION CHART

PP10A - <u>X</u> <u>X</u> <u>X</u> - <u>X</u> <u>X</u> <u>X</u>		
Fluid Connection A - 1 - 11-1/2 NPTF - 1 B - 1 - 11 BSP		
Fluid Cap and Manifold Material A - Aluminum S - Stainless Steel		
Hardware Material P - Plated Steel S - Stainless Steel		
Seat Material A - Santoprene S - Stainless Steel		
Ball Material A - Santoprene		
Diaphragm Material A - Santoprene M - Medical Grade Santoprene		
Fluid Section Service Kit Selection		PP10A - XXX - X <u>X</u> <u>X</u>
EXAMPLE: Model #PP10A-AAS-AAA		637401 - <u>X</u> <u>X</u>
Fluid Section Service Kit # 637401-AA		Ball — Diaphragm



OPERATING AND SAFETY PRECAUTIONS

READ, UNDERSTAND AND FOLLOW THIS INFORMATION TO AVOID INJURY AND PROPERTY DAMAGE.



⚠️ WARNING **EXCESSIVE AIR PRESSURE.** Can cause personal injury, pump damage or property damage.

- Do not exceed the maximum inlet air pressure as stated on the pump model plate.
- Be sure material hoses and other components are able to withstand fluid pressures developed by this pump. Check all hoses for damage or wear. Be certain dispensing device is clean and in proper working condition.

⚠️ WARNING **STATIC SPARK.** Can cause explosion resulting in severe injury or death. Ground pump and pumping system.

- Use the pump grounding screw terminal provided. Use ARO® part no. 94829 ground kit or connect a suitable ground wire (12 ga. minimum) to a good earth ground source.
- Secure pump, connections and all contact points to avoid vibration and generation of contact or static spark.
- Consult local building codes and electrical codes for specific grounding requirements.
- After grounding, periodically verify continuity of electrical path to ground. Test with an ohmmeter from each component (e.g., hoses, pump, clamps, container, spray gun, etc.) to ground, to ensure continuity. Ohmmeter should show 0.1 ohms or less.
- Submerge the outlet hose end, dispensing valve or device in the material being dispensed if possible. (Avoid free streaming of material being dispensed.)
- Use hoses incorporating a static wire.
- Use proper ventilation.
- Keep inflammables away from heat, open flames and sparks.
- Keep containers closed when not in use.

⚠️ WARNING Pump exhaust may contain contaminants. Can cause severe injury. Pipe exhaust away from work area and personnel.

- In the event of a diaphragm rupture, material can be forced out of the air exhaust muffler.
- Pipe the exhaust to a safe remote location when pumping hazardous or inflammable materials.
- Use a grounded 1" minimum ID hose between the pump and the muffler.

⚠️ WARNING **HAZARDOUS PRESSURE.** Can result in serious injury or property damage. Do not service or clean pump, hoses or dispensing valve while the system is pressurized.

- Disconnect air supply line and relieve pressure from the system by opening dispensing valve or device and / or carefully and slowly loosening and removing outlet hose or piping from pump.

⚠️ WARNING **HAZARDOUS MATERIALS.** Can cause serious injury or property damage. Do not attempt to return a pump to the factory or service center that contains hazardous material. Safe handling practices must comply with local and national laws and safety code requirements.

- Obtain Material Safety Data Sheets on all materials from the supplier for proper handling instructions.

⚠️ WARNING **EXPLOSION HAZARD.** Models containing aluminum wetted parts cannot be used with 1,1,1-trichloroethane, methylene chloride or other halogenated hydrocarbon solvents which may react and explode.

- Check pump motor section, fluid caps, manifolds and all wetted parts to assure compatibility before using with solvents of this type.

⚠️ WARNING **MISAPPLICATION HAZARD.** Do not use models containing aluminum wetted parts with food products for human consumption. Plated parts can contain trace amounts of lead.

⚠️ CAUTION Verify the chemical compatibility of the pump wetted parts and the substance being pumped, flushed or recirculated. Chemical compatibility may change with temperature and concentration of the chemical(s) within the substances being pumped, flushed or circulated. For specific fluid compatibility, consult the chemical manufacturer.

⚠️ CAUTION Maximum temperatures are based on mechanical stress only. Certain chemicals will significantly reduce maximum safe operating temperature. Consult the chemical manufacturer for chemical compatibility and temperature limits. Refer to PUMP DATA on page 1 of this manual.

⚠️ CAUTION Be certain all operators of this equipment have been trained for safe working practices, understand it's limitations, and wear safety goggles / equipment when required.

⚠️ CAUTION Do not use the pump for the structural support of the piping system. Be certain the system components are properly supported to prevent stress on the pump parts.

- Suction and discharge connections should be flexible connections (such as hose), not rigid piped, and should be compatible with the substance being pumped.

⚠️ CAUTION Prevent unnecessary damage to the pump. Do not allow pump to operate when out of material for long periods of time.

- Disconnect air line from pump when system sits idle for long periods of time.

⚠️ CAUTION Use only genuine ARO replacement parts to assure compatible pressure rating and longest service life.

NOTICE Replacement warning labels are available upon request: "Static Spark & Diaphragm Rupture" pn \ 94080.

⚠️ WARNING = Hazards or unsafe practices which could result in severe personal injury, death or substantial property damage.

⚠️ CAUTION = Hazards or unsafe practices which could result in minor personal injury, product or property damage.

NOTICE = Important installation, operation or maintenance information.



GENERAL DESCRIPTION

The ARO diaphragm pump offers high volume delivery even at low air pressure and a broad range of material compatibility options available. Refer to the model and option chart. ARO pumps feature stall resistant design, modular air motor / fluid sections.

Air operated double diaphragm pumps utilize a pressure differential in the air chambers to alternately create suction and positive fluid pressure in the fluid chambers, valve checks ensure a positive flow of fluid.

This diaphragm pump was developed to address the unique problems associated with pumping dry powders, which can "pack out" inside the pump fluid chambers, if not kept in a semi-fluid state.

This system incorporates the use of special valves to introduce air or inert gas* into the fluid chambers simultaneously to a pumping cycle, in a timed sequence which keeps the powder in a fluidized state during the transfer process.

THEORY OF OPERATION

The main air distribution valve (252) is a double pilot actuated four-way valve. It is a slave to the pump major air valve. The distribution valve recognizes the signal from two pump major air valve (259) ports (air dumps). These signals are converted into alternating output pressure distributions, which are injected into the fluid chambers during the pumping cycle to fluidize the powder as the diaphragm moves through the discharge stroke.

The flow of air supplied to the fluid chamber is controlled by the (248) filter / regulator. Under normal operating conditions, this is the primary control.

When air is supplied to the filter / regulator (248), the distribution valve directs the flow of air into the fluid chamber that will dispense first for 3 to 8 seconds. The time delay then supplies the start signal to open the main pump air supply valve. When the pump diaphragm reaches the end of the discharge stroke, it reverses direction. The distribution valve then shifts and shuts off the fluidizing air to the first fluid chamber as it applies a burst of air to the second fluid chamber and fluidizes the powder in the second chamber.

The air induction orifice (76) increases the air velocity prior to injection point because of the orifice and it prevents clogging of the injector feed line.

NOTE: The restart valve (258) is a bleed valve which will stop the pump and then restart the pump by re-initiating the time delay cycle.

***NOTE:** Use of other gases: Using only a gas to operate a 2" pump can be rather expensive because of the high volume needed. Separate air / gas inputs allow the fluidizing feature of this pump to utilize special inert gas, such as Nitrogen or Argon (air), if necessary and still allow use of standard compressed shop air for the pumping function.

The ability to introduce special gas also means special materials could be injected through the fluidization lines. Applications may include such materials as colorants, foaming agents, additives, neutralizers, etc.

AIR AND LUBE REQUIREMENTS

⚠ WARNING EXCESSIVE AIR PRESSURE. Can cause pump damage, personal injury or property damage. The pump air supply must be limited to 50 psig (3.4 bar) maximum inlet air pressure.

- The air supply line or hose to the pump should be adequately sized to carry a sufficient volume of air to the pump.

The material inlet supply tubing should not be too small or restrictive, which will inhibit material flow. The outlet material volume is governed not only by the air supply, but also by the material volume available at the inlet.

- Air supply provided should be filtered to provide clean, dry air. A filter capable of filtering out particles larger than 40 microns should be used on the air supply. There is no lubrication required other than the "O" ring lubricant which is applied during assembly or repair.
- If lubricated air is present, make sure that it is compatible with the Nitrile "O" rings in the air motor section of the pump.

NOTE: When using air for powder fluidization, make sure it is filtered and very dry.

INSTALLATION

⚠ WARNING THE PUMPING SYSTEM MUST BE GROUNDED TO PREVENT STATIC DISCHARGE. THIS INCLUDES THE PUMP AND ALL INPUT AND OUTPUT SUPPLY LINES AND RELATED SYSTEM DEVICES AND ACCESSORIES. FAILURE TO DO SO CAN RESULT IN EXPLOSION AND SERIOUS PERSONAL INJURY.

SYSTEM GROUNDING

- Consult local building codes and electrical codes for specific requirements.
- Must comply with all applicable Local and National codes for such applications.
- Grounding is accomplished through the ground lug and strap provided on the pump. Keep the grounding strap as short as possible.
- Safe operating conditions are the responsibility of the installer and operator.
- Secure the diaphragm pump legs to a suitable surface to avoid damage by excessive vibration.

OPERATING INSTRUCTIONS

START-UP

NOTE: PRIOR TO START-UP, MAKE SURE THE GROUNDING INSTRUCTIONS WERE FOLLOWED.

- Connect air supply to (263) main air supply control valve (30 - 40 psig/ 2.1 - 2.8 bar).
 - Turn the air on.
 - Attach air (or gas) to (248) filter / regulator.
- ⚠ CAUTION Do not apply excessive Fluidization Gas* Pressure (refer to note under "Theory Of Operation").**
- Verify that the (253) flow control is fully open.
 - At (248), turn on air (or inert gas) supply. There will be a 3 to 8 second time delay, during which the pump will be fluidizing any powder left in the pump from an earlier dispense. This time delay will occur on all start-ups.

OPERATION AND ADJUSTMENT

NOTE: Powder type materials can vary in flow-ability and the same settings may not work universally. Factors such as density and humidity can require changing the mixture of flow rate and fluidization air and some experimenting should be expected.

IMPORTANT: DO NOT TURN FILTER / REGULATOR (248) OFF. Positive air (or gas) pressure must be supplied to the filter / regulator to allow the pump to function. Powder will accumulate in the fluid caps if the pump is not allowed to expel excess material before the pump shuts down.

PP10A-XXX-XXX-A (en)

Restart can compress some powders to a solid that may cause the pump to fail. The pump should cycle until most of the powder has been purged before it is shut down.

CALIBRATION PROCEDURE ON INITIAL START-UP:

NOTE: Once these parameters are established for your specific application, they should not need to be changed.

1. Turn the flow and pressure on the (248) filter / regulator all the way up.
2. Slowly decrease pressure and flow until pump begins to labor (work harder).
3. Increase pressure and flow back to a point where the pump begins to run smoothly. This will optimize the air-to-powder mix and will help to establish the most efficient working parameters.

If the pump begins to cycle slowly (bog down), the powder can be purged by depressing the restart button. This will stop the pump and restart the aeration cycle and allow time to increase air flow to the aeration ports for proper material movement.

IMPORTANT

SHUT DOWN PROCEDURE - TO HELP PREVENT PACK-OUT

It is good operating practice to dry cycle the pump 5 - 10 seconds at the end of each dispense cycle. This can be accomplished by closing off the powder source at the suction of the pump or pull wand from material. This will help clear the pump chambers of any residual powder.

CAUTION Failure to ensure proper fluidization can result in internal parts breakage and pump failure.

MAINTENANCE

Refer to the part views and descriptions as provided on page 6 through 11 for parts identification and Service Kit information.

- Keep good records of service activity and include pump in preventive maintenance program.
- Certain ARO "Smart Parts" are indicated which should be available for fast repair and reduction of down time.
- Service kits are divided to service two separate diaphragm pump functions: 1. AIR SECTION, 2. FLUID SECTION. The FLUID SECTION is divided further to match typical part MATERIAL OPTIONS.
- Provide a clean work surface to protect sensitive internal moving parts from contamination from dirt and foreign matter during service disassembly and reassembly.
- Before disassembling, empty captured material in the outlet manifold by turning the pump upside down to drain material from the pump.

SCHEMATIC CIRCUIT

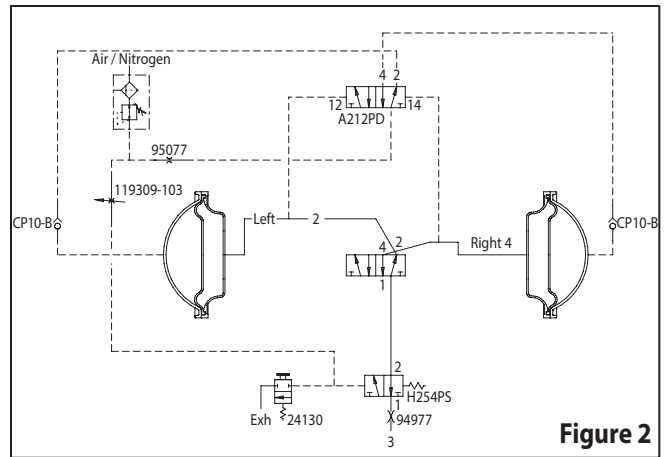

Figure 2

TROUBLESHOOTING

Product discharged from exhaust outlet.

- Check for diaphragm rupture.
- Check tightness of (14) diaphragm screw.

Motor blows air or stalls.

- Check (176) check valve for damage or wear.
- Check for restrictions in valve / exhaust.

Low output volume, erratic flow, or no flow.

- Check air supply.
- Check for plugged outlet hose.
- Check for kinked (restrictive) outlet material hose.
- Check for kinked (restrictive) or collapsed inlet material hose.
- Suction hose must be a non-collapsing type, conductive and capable of pulling a high vacuum (up to 30" mercury).
- Check all joints on the inlet manifolds and suction connections. Connection must be air tight.
- Inspect the pump for solid objects lodged in the diaphragm chamber or the seat area.



TYPICAL CROSS SECTION

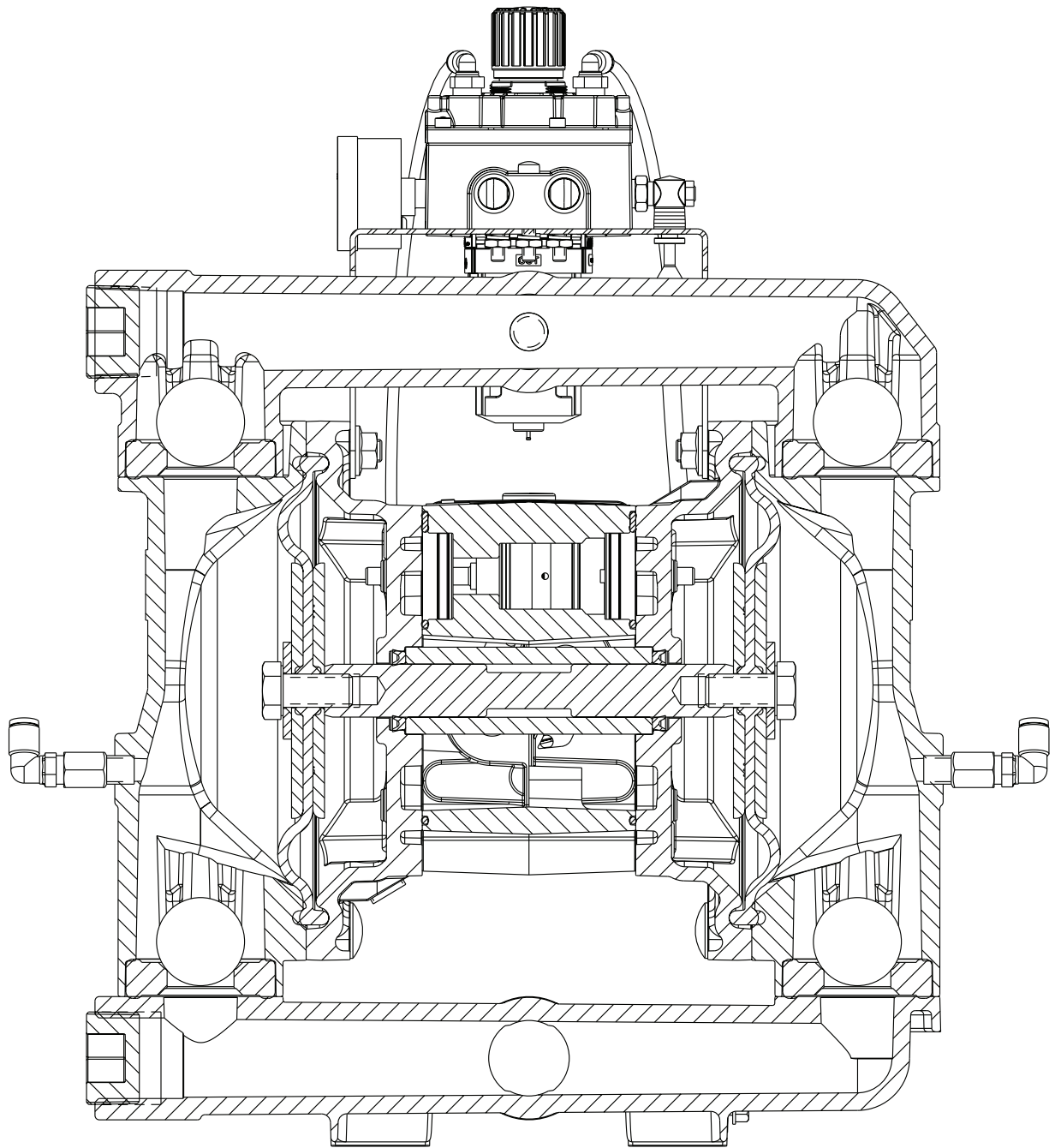

Figure 3

Illinois Location:

(847) 841-7867
860 Church Rd Elgin, IL 61

Minnesota Location:

(651) 758-7867
330 Mill Bay South Suite :
Afton, MN 55001

PumpSupplyInc.com



PARTS LIST / PP10A-XXX-XXX-A FLUID SECTION

FLUID SECTION SERVICE KITS (637401-XXX or 637401-XX)

- ★ **For Fluid Kits With Seats:** 637401-XXX fluid section service kits include: Seats (see SEAT Option, refer to -XXX in chart below), Balls (see BALL Option, refer to -XXX in chart below), Diaphragms (see DIAPHRAGM Option, refer to -XXX in chart below), and items 19, 70, 144, 175 (listed below) plus items 174 and 94276 Lubriplate® FML-2 grease (page 7).
- ★ **For Fluid Kits Without Seats:** 637401-XX fluid section service kits include: Balls (see BALL Option, refer to -XX in chart below), Diaphragms (see DIAPHRAGM Option, refer to -XX in chart below), and items 19, 70, 144, 175 (listed below) plus items 174 and 94276 Lubriplate® FML-2 grease (page 7).

SEAT OPTIONS PP10A-XXX-XXX-A				
★ "21"				
-XXX	Seat	Qty	[Mtl]	
-AXX	96152-A	(4)	[Sp]	
-SXX	96151	(4)	[SS]	

BALL OPTIONS PP10A-XXX-XXX-A				
★ "22" (2-1/2" diameter)				
-XXX	Ball	Qty	[Mtl]	
-XAX	93278-A	(4)	[Sp]	

EXTERNAL HARDWARE OPTIONS PP10A-XXX-XXX-A						
Item	Description (size)	Qty	Plated Steel PP10A-XXP-XXX-A		Stainless Steel PP10A-XXS-XXX-A	
			Part No.	[Mtl]	Part No.	[Mtl]
26	Screw (M8 x 1.25 - 6g x 30 mm)	(8)	95880-1	[C]	95880	[SS]
27	Screw (M8 x 1.25 - 6g x 40 mm)	(20)	95896-1	[C]	95896	[SS]
29	Nut (M8 x 1.25 - 6h)	(20)	95879-1	[C]	95879	[SS]

DIAPHRAGM OPTIONS PP10A-XXX-XXX-A											
-XXX	★ Service Kits with Seats -XXX = (Seat) -XXX = (Ball) -XXX = (Diaphragm)	★ Service Kit without Seats -XX = (Ball) -XX = (Diaphragm)	★ "7"			★ "19"			★ "33"		
			Diaphragm	Qty	[Mtl]	"O" Ring	Qty	[Mtl]	"O" Ring	Qty	[Mtl]
-XXA	637401-XXA	637401-XA	96267-A	(2)	[Sp]	93280	(4)	[E]	93279	(4)	[E]
-XXM	637401-XXM	637401-XM	96267-M	(2)	[MSp]	93282	(4)	[T]	93281	(4)	[T]

MATERIAL CODE	
[A]	= Aluminum
[B]	= Nitrile
[C]	= Carbon Steel
[Co]	= Copper
[MSp]	= Medical Grade Santoprene
[Sp]	= Santoprene
[SS]	= Stainless Steel
[T]	= PTFE

MANIFOLD CONNECTION / FLUID CAP MATERIAL OPTIONS PP10A-XXX-XXX-A										
Item	Description (size)	Qty	Aluminum				Stainless Steel			
			NPT		BSP		NPT		BSP	
			PP10A-AAx-XXX	[Mtl]	PP10A-BAX-XXX	[Mtl]	PP10A-ASX-XXX	[Mtl]	PP10A-BSX-XXX	[Mtl]
6	Back-Up Washer	(2)	95990-3	[A]	95990-3	[A]	95990-1	[SS]	95990-1	[SS]
15	Fluid Cap	(2)	97684	[A]	97684	[A]	97677	[SS]	97677	[SS]
60	Inlet Manifold	(1)	97686-1	[A]	97686-2	[A]	97679-1	[SS]	97679-2	[SS]
61	Outlet Manifold	(1)	97687-1	[A]	97687-2	[A]	97681-1	[SS]	97681-2	[SS]
63	Pipe Plug (1 - 11-1/2 NPT)	(2)	Y17-125	[A]	-----	---	Y17-55-S	[SS]	-----	---
	(R1, 1 - 11 BSP)	(2)	-----	---	96160-2	[A]	-----	---	96160-1	[SS]
255	Pipe Plug (1/4"-18 NPT)	(2)	Y17-51-S	[A]	Y17-51-S	[A]	Y17-51-S	[SS]	Y17-51-S	[SS]

COMMON PARTS										
Item	Description (size)	Qty	Part No.	[Mtl]	Item	Description (size)	Qty	Part No.	[Mtl]	
1	Connecting Rod	(1)	97146	[C]	131	Screw (M8 x 1.25 - 6g x 95 mm)	(4)	96001	[C]	
5	Back-Up Washer	(2)	95990-3	[A]	✓ ★ 144	"U" Cup (3/4" x 1-1/8" OD)	(2)	Y186-49	[B]	
9	Washer	(2)	93189-1	[SS]	✓ ★ 175	"O" Ring (5/8" x 13/16" OD)	(2)	Y325-114	[B]	
14	Bolt (M12 x 1.75-6g x 25mm)	(2)	95997	[SS]	✓ 180	Washer (0.406" ID x 0.031" thick)	(4)	96006	[Co]	
68	Air Cap	(1)	95994-6	[A]	181	Roll Pin (Ø 0.156 x 0.500)	(4)	Y178-52-S	[SS]	
69	Air Cap	(1)	95994-5	[A]	195	Nut (M8 x 1.25 - 6h)	(4)	96005	[SS]	
✓ ★ 70	Gasket	(2)	95843	[B]	208	Label	(1)	93007		
74	Pipe Plug (1/4 - 18 NPT)	(1)	Y17-51-N	[C]	250	Screw, Self-Tapping (1/4" - 14 x 1/2")	(1)	Y334-104-C	[C]	
126	Pipe Plug (1/4 - 18 NPT)	(1)	Y17-13-S	[SS]						

✓ Air Motor Kit parts, see pages 8 and 9.

FLUID SECTION DISASSEMBLY

1. Remove (61) outlet manifold and (60) inlet manifold.
2. Remove (22) balls, (19) "O" rings (if applicable) and (21) seats.
3. Remove (15) fluid caps.
4. Remove the (6) diaphragm washer, (7) diaphragm and (5) back-up washer.

NOTE: Do not scratch or mar the surface of (1) diaphragm rod.

FLUID SECTION ASSEMBLY

- Assemble in reverse order of disassembly. Refer to the torque requirements on page 7.
- Clean and inspect all parts. Replace worn or damaged parts with new parts as required.
- Lubricate® (1) diaphragm rod and (144) "U" cups with Lubriplate FML-2 grease (94276 grease packet is included in service kit).
- Examine torque settings after pump has been re-started and run a while.

PARTS LIST / PP10A-XXX-XXX-A FLUID SECTION

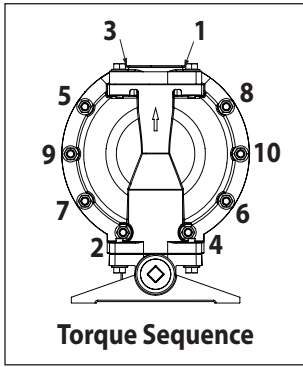

FOR THE AIR MOTOR SECTION,
SEE PAGES 8 AND 9.

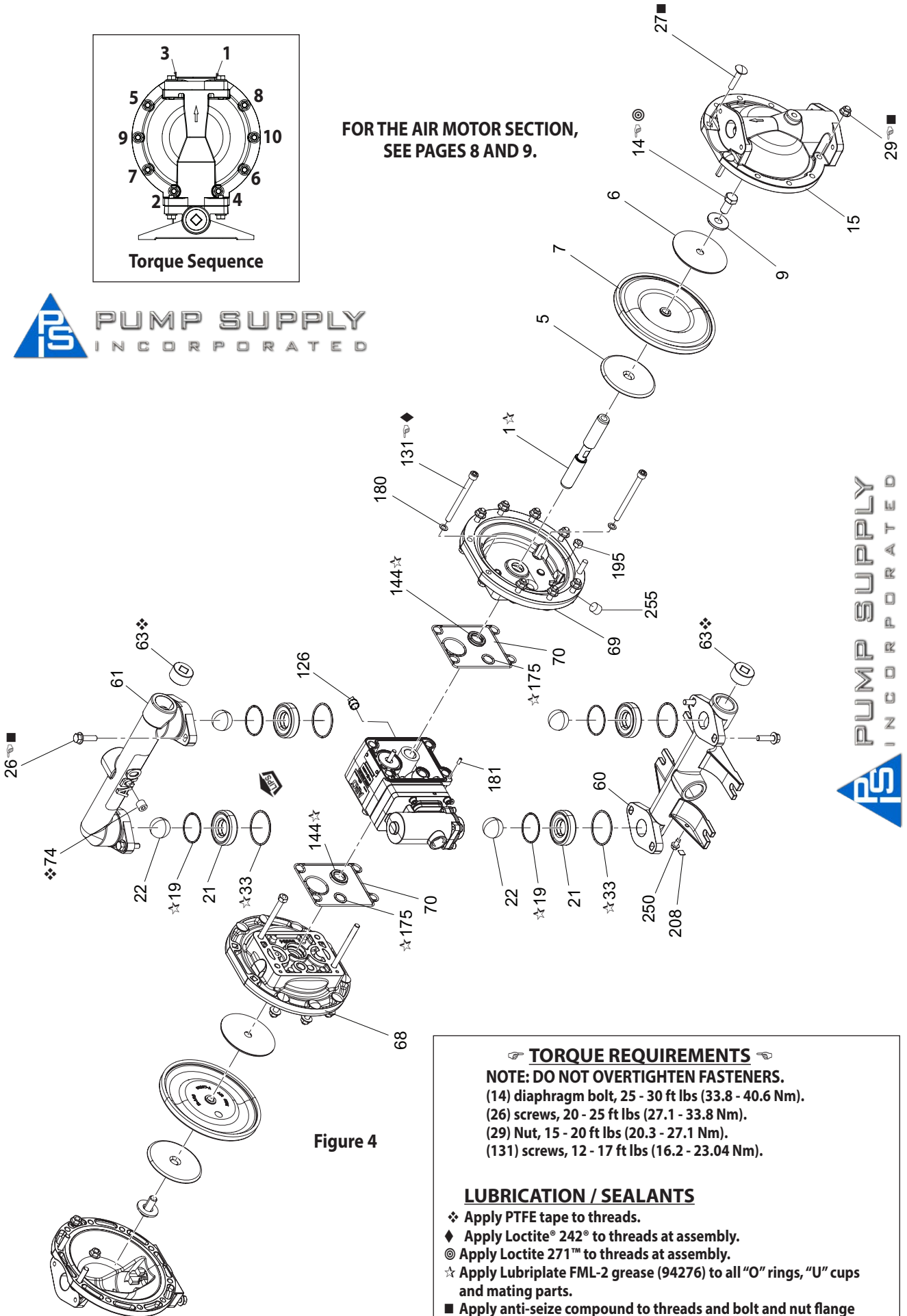

Figure 4

TORQUE REQUIREMENTS

NOTE: DO NOT OVERTIGHTEN FASTENERS.
 (14) diaphragm bolt, 25 - 30 ft lbs (33.8 - 40.6 Nm).
 (26) screws, 20 - 25 ft lbs (27.1 - 33.8 Nm).
 (29) Nut, 15 - 20 ft lbs (20.3 - 27.1 Nm).
 (131) screws, 12 - 17 ft lbs (16.2 - 23.04 Nm).

LUBRICATION / SEALANTS

- ❖ Apply PTFE tape to threads.
- ◆ Apply Loctite® 242® to threads at assembly.
- ⊙ Apply Loctite 271™ to threads at assembly.
- ☆ Apply Lubriplate FML-2 grease (94276) to all "O" rings, "U" cups and mating parts.
- Apply anti-seize compound to threads and bolt and nut flange heads which contact pump case when using stainless steel fasteners.

PARTS LIST / PP10A-XXX-XXX-A AIR MOTOR SECTION

✓ Indicates parts included in 637397 air section repair kit, plus items 70, 144, 175 and 180 (page 6).

AIR MOTOR PARTS LIST

Item	Description (size)	(Qty)	Part No.	[Mtl]
101	Center Body	(1)	97025	[A]
103	Bushing	(1)	97672	[Bz]
105	Screw (M6 x 1 - 6g x 20 mm)	(4)	95991	[SS]
111	Spool	(1)	95835	[D]
118	Actuator Pin (0.250" x 1.572" long)	(2)	95999	[SS]
121	Plug	(2)	95123	[D]
128	Plug	(1)	Y17-50-S	[SS]
✓ 132	Gasket	(2)	96170	[B]
133	Lockwasher (1/4")	(4)	Y117-416-C	[C]
134	Screw (M6 x 1 - 6g x 35 mm)	(4)	97745	[SS]
135	Valve Housing	(1)	95942-1	[A]
136	Plug	(1)	95941	[A]
✓ 137	Gasket	(1)	95844	[B]
✓ 138	"U" Cup (3/16" x 1-5/8" OD)	(1)	Y186-53	[B]
✓ 139	"U" Cup (3/16" x 1-1/8" OD)	(1)	Y186-49	[B]
140	Valve Insert	(1)	95838	[Ck]
141	Valve Plate	(1)	95885	[Ck]

MATERIAL CODE

- [A] = Aluminum [C] = Carbon Steel [SS] = Stainless Steel
- [B] = Nitrile [Ck] = Ceramic [U] = Polyurethane
- [Br] = Brass [D] = Acetal
- [Bz] = Bronze [Sp] = Santoprene

AIR MOTOR SECTION SERVICE

Service is divided into two parts - 1. Pilot Valve, 2. Major Valve.

GENERAL REASSEMBLY NOTES:

- Air motor section service is continued from fluid section repair.
- Inspect and replace old parts with new parts as necessary. Look for deep scratches on metallic surfaces, and nicks or cuts in "O" rings.
- Take precautions to prevent cutting "O" rings upon installation.
- Lubricate "O" rings with Lubriplate FML-2 grease.
- Do not over-tighten fasteners, refer to torque specification block on view.
- Re-torque fasteners following re-start.
- Service Tools - To aid in the installation of (168) "O" rings onto the (167) pilot piston, use tool #204130-T, available from ARO.

PILOT VALVE DISASSEMBLY

1. A light tap on (118) should expose the opposite (121) sleeve, (167) pilot piston and other parts.
2. Remove (170) sleeve. Inspect inner bore of sleeve for damage.

PILOT VALVE REASSEMBLY

1. Clean and lubricate parts not being replaced from service kit.
2. Install new (171 and 172) "O" rings. Replace (170) sleeve.
3. Install new (168) "O" rings and (169) seal - Note the lip direction. Lubricate and replace (167) pilot piston.
4. Reassemble remaining parts. Replace (173 and 174) "O" rings.

Item	Description (size)	(Qty)	Part No.	[Mtl]
✓ 166	Bottom Gasket	(2)	96171	[B]
✓ 167	Pilot Piston (includes 168 and 169)	(1)	67164	[D]
168	"O" Ring (3/32" x 5/8" OD)	(2)	94433	[U]
169	"U" Cup (1/8" x 7/8" OD)	(1)	Y240-9	[B]
170	Piston Sleeve	(1)	94081	[D]
✓ 171	"O" Ring (3/32" x 1-1/8" OD)	(1)	Y325-119	[B]
✓ 172	"O" Ring (0.70" x 1-1/8" OD)	(1)	Y325-22	[B]
✓ 173	"O" Ring (0.103" x 1-3/16" OD)	(2)	Y325-123	[B]
✓ 174	"O" Ring (0.139" x 1/2" OD)	(2)	Y325-202	[B]
✓ 176	Diaphragm (check valve)	(2)	95845	[Sp]
✓ 200	Gasket	(1)	96172	[B]
201	Silencer	(1)	350-568	[C]
233	Adapter Plate	(1)	95832	[A]
285	Adapter Plate	(1)	97703	[A]
✓	Lubriplate FML-2 Grease	(1)	94276	
	Lubriplate Grease, 10 Pack		637308	

MAJOR VALVE DISASSEMBLY

1. Remove (135) valve block and (233) adapter plate, exposing (166 and 132) gaskets and (176) checks.
2. Remove (233) adapter plate, releasing (140) valve insert, (141) valve plate, (200) gaskets.
3. Remove (136) plug and (137) "O" ring, releasing (111) spool.

MAJOR VALVE REASSEMBLY

1. Install new (138 and 139) "U" cups on (111) spool - **LIPS MUST FACE EACH OTHER.**
2. Insert (111) spool into (135) valve housing.
3. Install (137) "O" rings on (136) plug and assemble plug to (135) valve housing, securing with (105) screws.
4. Install (140) valve insert, (141) gasket into (135) valve housing. **NOTE:** Assemble (140) valve insert with "dished" side toward (141) valve plate. Assemble (141) valve plate with part number identification toward (140) valve insert.
5. Assemble (200) gaskets and (233) adapter plate to (135) valve housing. **NOTE:** Tighten screws to 40 - 50 in. lbs (4.5 - 5.6 Nm).
6. Assemble (132 and 166) gaskets and (176) checks to (101) center body.
7. Assemble (135) valve housing and components to (101) center body, securing with (134) screws. **NOTE:** Tighten screws to 40 - 50 in. lbs (4.5 - 5.6 Nm).



PP10A-XXX-XXX-A (en)

PARTS LIST / PP10A-XXX-XXX-A AIR MOTOR SECTION

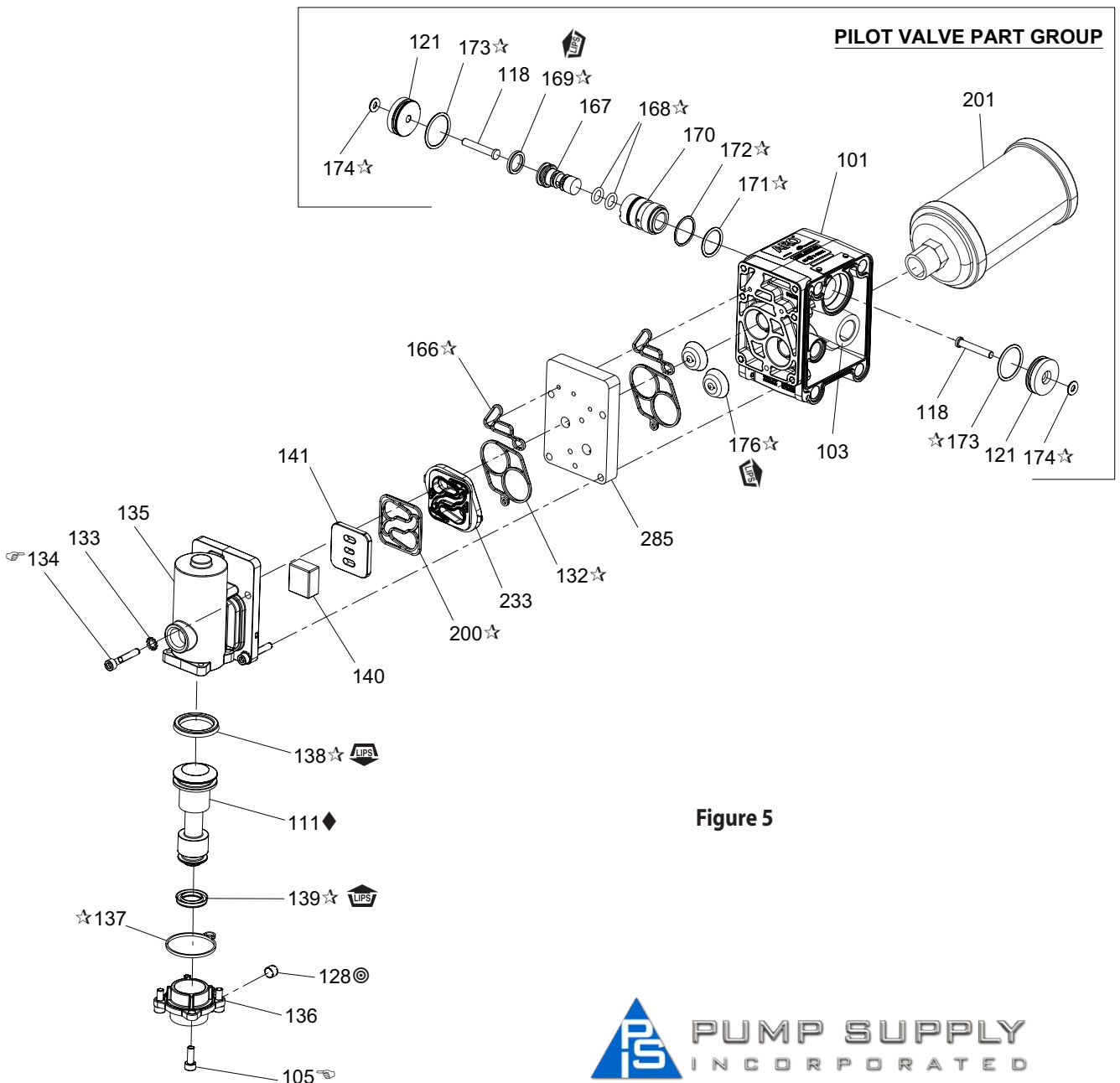

Figure 5



TORQUE REQUIREMENTS
 NOTE: DO NOT OVERTIGHTEN FASTENERS.
 ALL FASTENERS ARE METRIC.
 (105) screw, 40 - 50 in. lbs (4.5 - 5.6 Nm).
 (134) screw, 40 - 50 in. lbs (4.5 - 5.6 Nm).

LUBRICATION / SEALANTS
 ☆ Apply Lubriplate FML-2 grease to all "O" rings, "U" cups and mating parts.
 ◎ Apply Loctite 271 to threads at assembly.
 ◆ Apply Lubricate grease to Valve Spool assemblies and Bores.

A replacement major valve service assembly is available separately, which includes the following:
 637395-8 for models PP10A-XXX-XXX-A: 105(4), 111, 128, 132 (2), 133 (4), 134 (4), 135, 136, 137, 138, 139, 140, 141, 166 (2), 176 (2), 200, 233, 256, 257, 258, 263, 264, 265 and 285.

PARTS LIST / PP10A-XXX-XXX-A CONTROL SECTION

AIR CONTROL PARTS LIST

Item	Description (size)	(Qty)	Part No.	Item	Description (size)	(Qty)	Part No.
76	Adapter (1/8 - 27 NPTF - 1)	(2)	94817	260	Check Valve	(2)	CP10-B
77	Elbow (1/4" OD tube x 1/8 - 27 NPT)	(2)	59756-56	261	Mounting Bracket	(1)	97704
78	Tube (1/4" OD x 20")	(2)	59675-(0)	262	Pipe Plug (1/4 - 18 NPT x 7/16")	(2)	Y17-51-N
245	Air Line Connection Kit (not shown)	(1)	67223	263	Control Valve	(1)	H254PS
246	Adapter (1/8 NPTF male x #10 - 32 female)	(1)	59629	264	Pipe Plug with 0.078" orifice (1/2 - 14 NPT)	(1)	94977
247	Gauge (0 - 160 psig / 0 - 11 bar)	(1)	29850	265	Nipple (1/2 - 14 NPTF - 1 x 1-1/8")	(1)	Y27-4-C
248	Piggyback Filter / Regulator	(1)	P39124-100	267	Tube (1/4" OD x 20")	(1)	59675-(0)
248A	Gauge Port Block	(1)	104467	268	Tube (1/4" OD x 5")	(2)	59675-(0)
249	Nipple (1/4 - 18 NPTF - 1 x 1-5/16")	(1)	1950	269	Tube (5/32" OD x 29")	(1)	94981-(0)
251	Restrictor	(1)	95077	270	Tube (5/32" OD x 29")	(1)	94981-(0)
252	Alpha Valve, 4-Way	(1)	A212PD	271	Elbow (1/4" OD tube x 1/4 - 18 NPT)	(2)	59756-156
253	Flow Control (1/4" OD tube x #10 - 32)	(1)	119309-103	272	Screw (#10 - 24 x 1-1/4")	(3)	Y19-113-C
254	Reducer (1/4" OD tube x 5/32" OD tube)	(1)	59765-4	273	Nut (#10 - 24)	(3)	Y22-10-C
256	Connector (1/4" OD tube x 1/8 - 27 NPT)	(5)	59474-56	274	Lock Washer (#10)	(3)	Y14-10-C
257	Adapter (1/8 - 27 PTF)	(1)	94812				
258	Button Bleed Valve (1/8 - 27 NPTF)	(1)	24130	①	Bulk Tubing (1/4" OD x 100')	(1)	59675-100
259	Elbow (5/32" OD tube x 1/8 - 27 NPT)	(4)	59756-4	②	Bulk Tubing (5/32" OD x 100')	(1)	94981-100

PARTS LIST / PP10A-XXX-XXX-A CONTROL SECTION

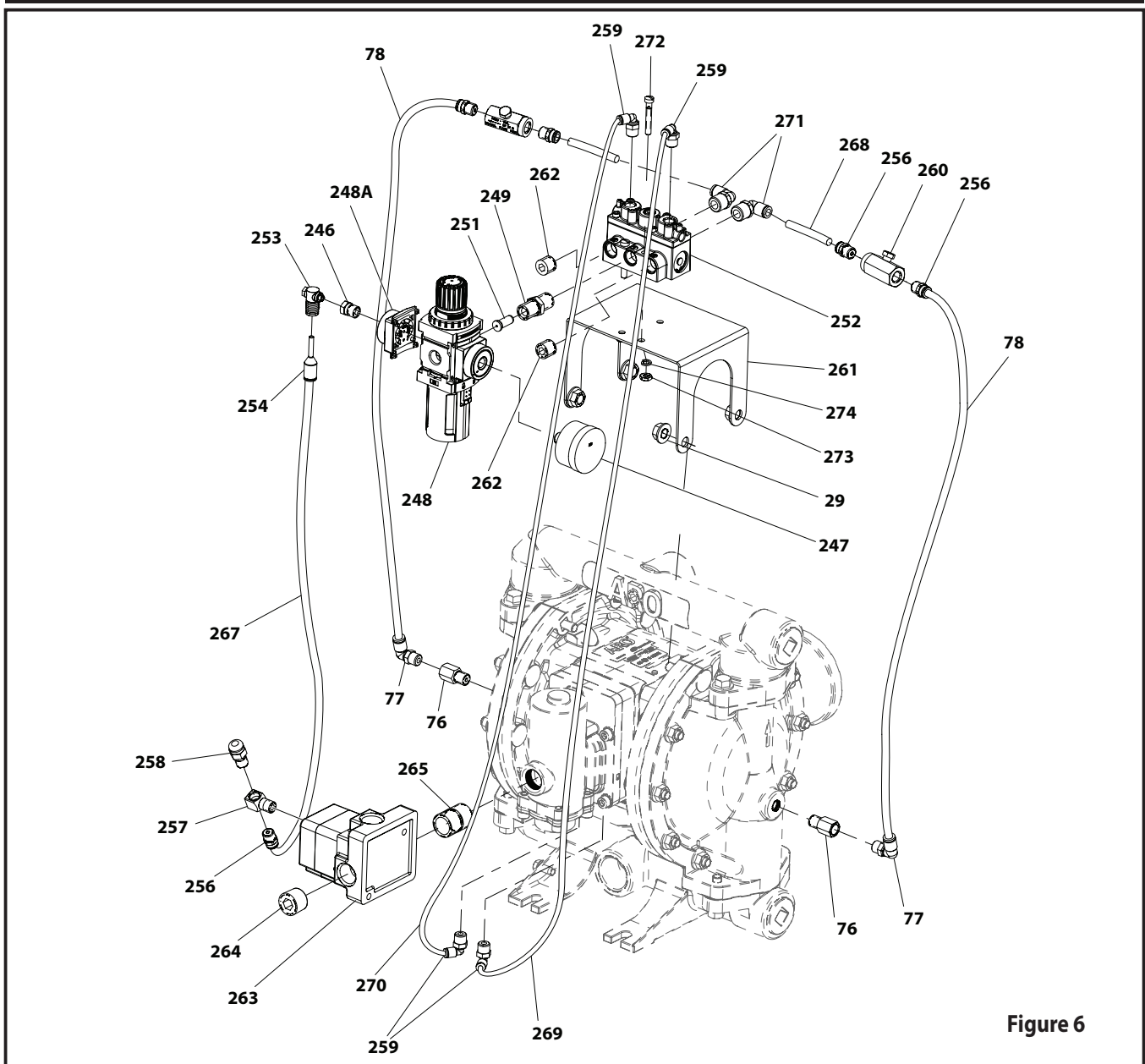
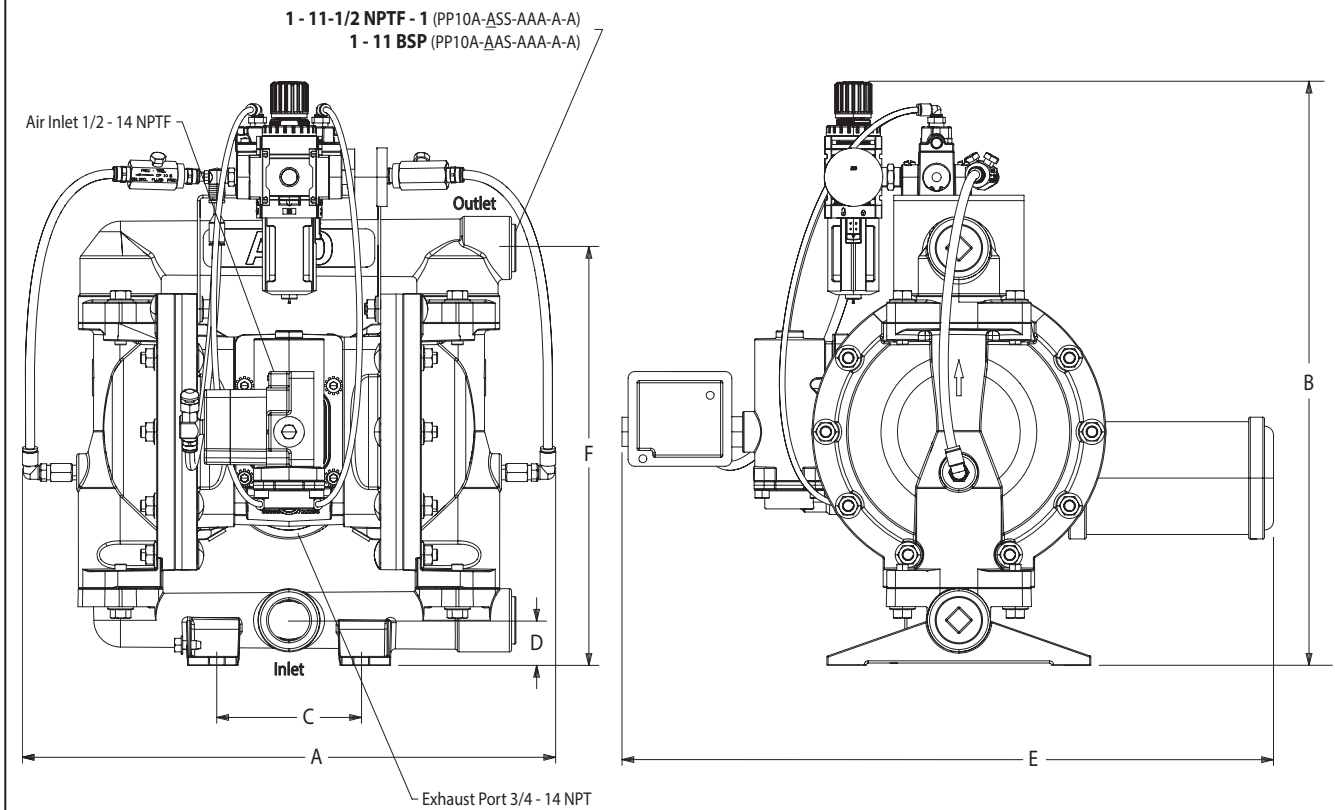

Figure 6

DIMENSIONAL DATA

Dimensions shown are for reference only. They are displayed in inches and millimeters (mm).



A - 375.21 mm
E - 457.53 mm

B - see below
F - 293.67 mm

DIMENSIONS

C - 101.6 mm

D - 31.75 mm

<u>Pump Model</u>	"B"
PP10A-ASS-AAA-A	410.84 mm
PP10A-AAS-AAA-A	410.25 mm

Figure 7

Illinois Location:
(847) 841-7867
860 Church Rd Elgin, IL 60120

Minnesota Location:
(651) 758-7867
330 Mill Bay South Suite 100
Afton, MN 55001

PumpSupplyInc.com

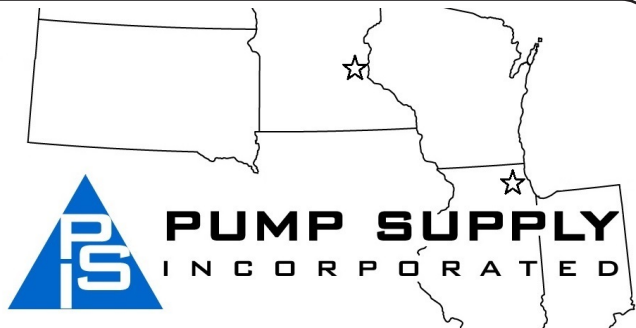

Illinois Location:
(847) 841-7867
860 Church Rd Elgin, IL 60120

Minnesota Location:
(651) 758-7867
330 Mill Bay South Suite
Afton, MN 55001

PumpSupplyInc.com



The image shows a map of the United States with two stars indicating office locations: one in Illinois and one in Minnesota. Below the map is the Pump Supply Incorporated logo, which consists of a blue triangle containing the letters 'PS' in white, followed by the text 'PUMP SUPPLY INCORPORATED' in a bold, sans-serif font.