

SALES AND ENGINEERING DATA

RATIO SERIES:	1:1
FLUID PSIG RANGE:	20 - 120

PF20R-XXX-SXX-B and PF20Y-XXX-SXX-B 2" METALLIC FLAP VALVE DIAPHRAGM PUMP

RELEASED: 2-10-05
REVISED: 9-15-11
(REV: 04) S-1343

DIMENSIONAL DATA

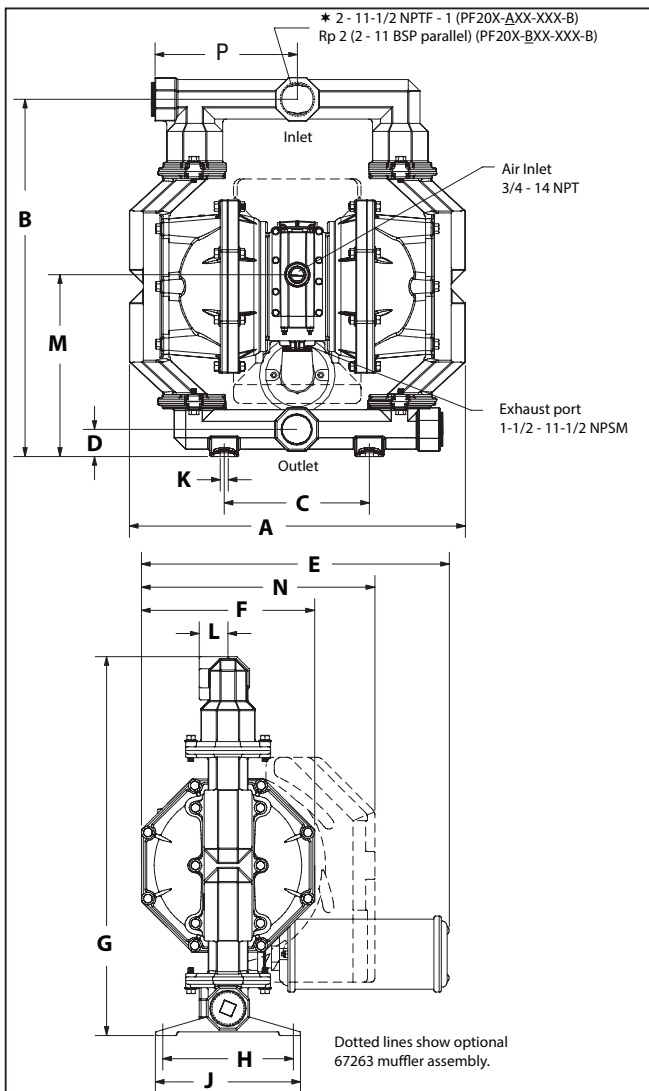

DIMENSIONS

A 23-9/32" (591.3 mm)	F 12" (304.8 mm)	L see below
B 24-3/4" (628.7 mm)	G 26-1/4" (666.8 mm)	M see below
C 10-1/16" (255.6 mm)	H 9-1/16" (230.2 mm)	N 16-3/16" (410.8 mm)
D see below	J 10-1/16" (255.6 mm)	P see below
E 21-11/32" (541.9 mm)	K 916" (14.3 mm)	

	PF20X-XCX-XXX-B	PF20X-XSX-XXX-B
D	1-7/8" (47.6 mm)	2-1/2" (63.5 mm)
L	2" (50.8 mm)	2-3/32" (53 mm)
M	12-19/32" (319.9 mm)	13-1/4" (336.6 mm)
P	9-7/8" (250.7 mm)	----

Note: * Side Discharge Ports are not available on PX20X-XSX-X-B Models.
Dimensions are shown in inches and (mm), supplied for reference only and are typically rounded up to the nearest 1/16 inch.

SPECIFICATIONS

CONSTRUCTION

Model Series	PF20R-XXX-SXX-B PF20Y-XXX-SXX-B
Pump Type	Metallic, Air operated, Flap Valve, Double diaphragm
Ratio	1:1
Material Inlet / Outlet (female)	
PF20X-AXX-SXX-B	2 - 11-1/2 NPTF - 1
PF20X-BXX-SXX-B	Rp 2 (2 - 11 BSP parallel)
Air Inlet (female)	3/4 - 14 NPT
Air Exhaust (female)	1-1/2 - 11-1/2 NPSM
Weight	
PF20X-XSX-SXX-B	180.6 lbs (81.9 kgs)
PF20X-XCX-SXX-B	178.7 lbs (81.1 kgs)
Air Section Service Kit	637369
Fluid Section Service Kit	637310-XX

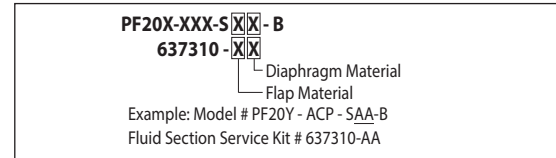

PERFORMANCE

Air Inlet Pressure Range	20 - 120 psig (1.4 - 8.3 bar)
Maximum Material Inlet Pressure	10 psig (0.69 bar)
Fluid Pressure Range	20 - 120 psig (1.4 - 8.3 bar)
Maximum Flow Rate	172 gpm (651 lpm)
Displacement / Cycle @ 100 psig	1.4 gpm (5.3 lpm)
Maximum Particle Size	2" dia (50 mm) semi - solids
Maximum Temperature Limits (diaphragm / flap / bumper material)	
E.P.R / EPDM	-60° to 280°F (-51° to 138°C)
Nitrile	10° to 180°F (-12° to 82°C)
Polyurethane	10° to 150°F (-12° to 66°C)
Santoprene®	-40° to 225°F (-40° to 107°C)
PTFE	40° to 225°F (4° to 107°C)
Viton®	-40° to 350°F (-40° to 177°C)
Noise Level @ 70 psig, 60 cpm①	85.0 dB(A)②

- ① Tested with 67263 muffer assembly installed.
② The pump sound pressure level has been updated to an Equivalent Continuous Sound Level (LAeq) to meet the intent of ANSI S1.13-1971, CAGI-PNEUROP S5.1 using four microphone locations.

ACCESSORIES:

- 66473 Air Line Connection Kit
- 67263 Continuous Muffer Assembly
- 94117 Int. Muffer

ARO

Ingersoll Rand®

Illinois Location:
(847) 841-7867
860 Church Rd Elgin, IL 61

Minnesota Location:
(651) 758-7867
330 Mill Bay South Suite
Afton, MN 55001

PumpSupplyInc.com



PUMP SUPPLY
INCORPORATED

PERFORMANCE CURVES

PF20R-XXX-XXX-B / PF20Y-XXX-XXX-B 2" METALLIC FLAP VALVE DIAPHRAGM PUMP

