

Hydra·Cell[®]

METERING SOLUTIONS™

P600 Metering Pump

Installation, Operation & Maintenance

P600-991-2400A

Metallic pump shown

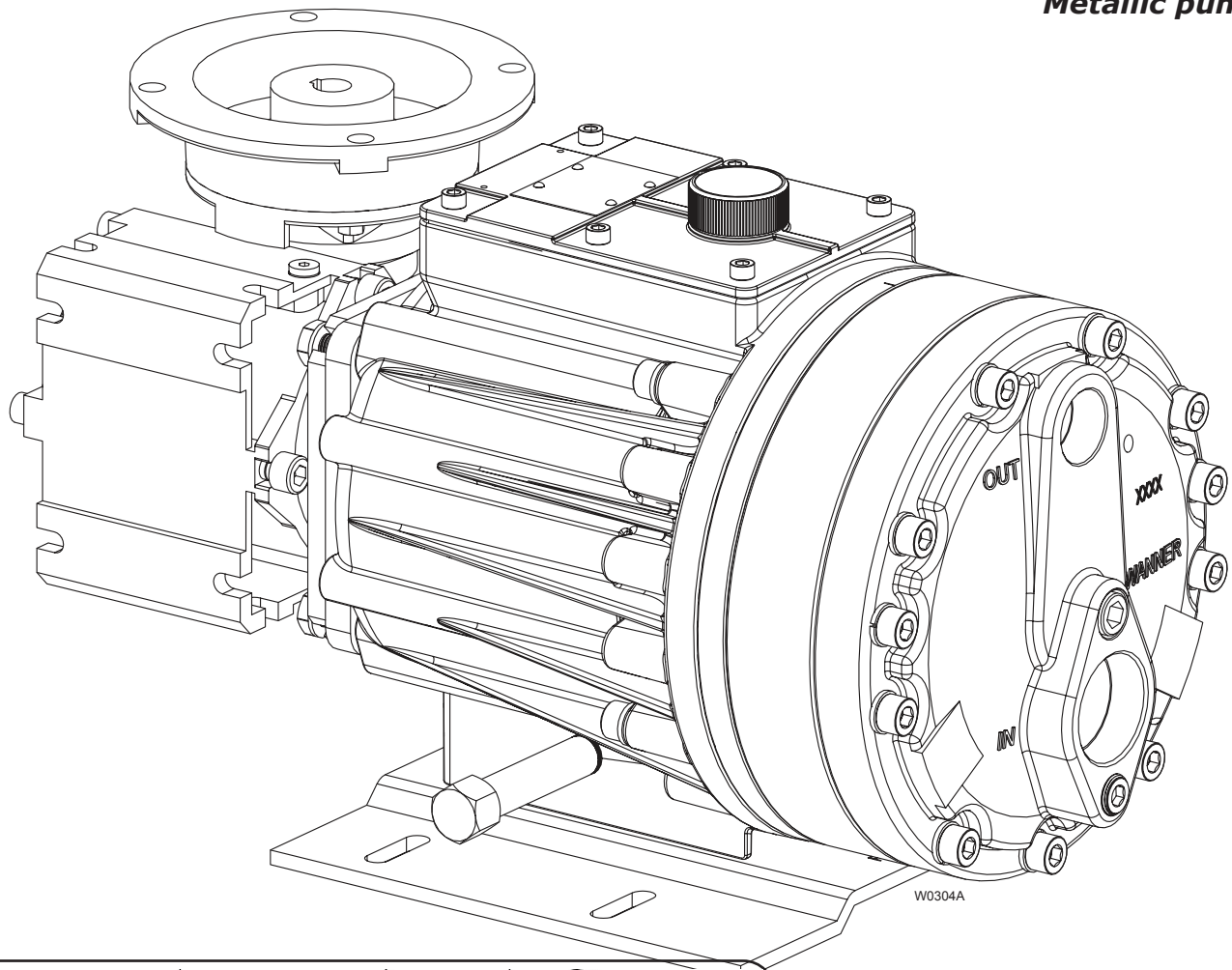

Illinois Location:
(847) 841-7867

860 Church Rd Elgin, IL 60120

Minnesota Location:

(651) 758-7867

330 Mill Bay South Suite
Afton, MN 55001

PumpSupplyInc.com



 **Wanner Engineering, Inc.**



P600 Contents



	Page
Operation	2
Specifications	2
Dimensions	3
Installation	6
Calibration	8
Maintenance	9
Fluid End	
Service	10
Parts List	13
Hydraulic End Service	17
Parts List	17
Reducer Parts List.....	18
Troubleshooting.....	21
Replacement Parts Kits	22
Warranty.....	24

Component Identification

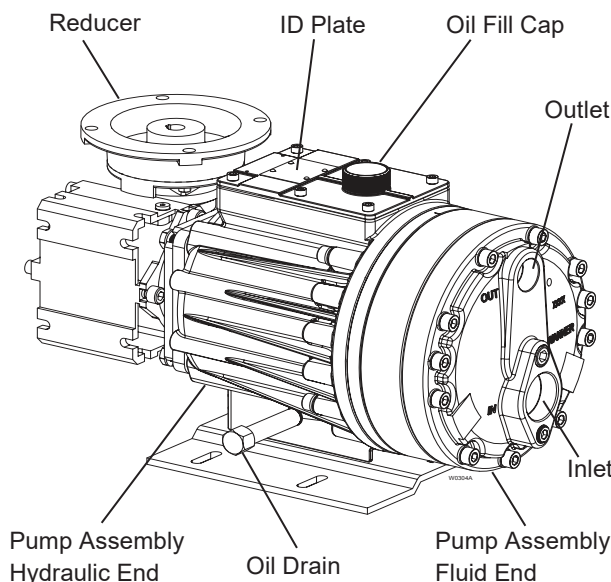

P600 Operation

Hydra-Cell Metering Solutions Pumps are hydraulically-actuated, hydraulically-balanced diaphragm metering pumps that exceed API 675 performance standards of ±1% steady state accuracy, ±3% linearity and ±3% repeatability.

Due to their multiple diaphragm design, the P Series metering pumps, with the exception of the P100, provide virtually "pulse-free" linear flow. Unlike conventional single diaphragm metering pumps, this linear flow reduces the need for pulsation dampeners and increases the reliability, performance, and safety of the metering pump system.

Pump operation and plunger activation are accomplished through a crankshaft (P100, P200 and P300) or wobble plate (P400, P500 and P600). Horizontal disk check valves allow for the pumping of particulates that ordinarily collect on vertical ball check valves common to conventional metering pumps.

P Series pumps utilize speed to adjust flow rate through a motor and variable-frequency drive (VFD), eliminating the need for mechanical adjustment.



Illinois Location:
 (847) 841-7867
 860 Church Rd Elgin, IL 60123

Minnesota Location:
 (651) 758-7867
 330 Mill Bay South Suite 1511 Afton, MN 55001

P600 Specifications

Diaphragms per Liquid End	3 (Kel-Cell pistons)	
Flow Control	Electronic variable speed drive	
Steady State Accuracy	±1%	
Linearity	±3%	
Repeatability	±3%	
Maximum Pressure		
Metallic Head:	1000 psi (70 bar)	
Non-Metallic Head: Polypropylene:	250 psi (17 bar)	
PVDF:	350 psi (24 bar)	
Maximum Inlet Pressure	250 psi (17 bar)	
Fluid Operating Temperatures*		
Metallic Head:	250°F (121°C)	
Non-Metallic Head:	140°F (60°C)	
* Consult factory for correct component selection for temperatures from 160°F (71°C) to 250°F (121°C).		
Inlet Port	1 1/2 inch NPT or BSPT	
Discharge Port	1 inch NPT or BSPT	
Maximum Solids	500 microns	
Shaft Rotation	Bi-directional	
Materials Used	See Replacement Parts Kits Section for individual pump materials.	
Oil Capacity	2.5 US quart (2.4 liters)	
Weight	FlexBloc 63	FlexBloc 75
Metallic Head:	146 lbs (66.2 kg)	172.1 lbs (78.1 kg)
Non-Metallic Head:	111 lbs (50.3 kg)	137.1 lbs (62.2 kg)



P600 Specifications (Cont'd)

Performance Maximum Flow at Designated Pressure - Imperial *

All Pump Heads (gph)		Metallic Pump Heads (gph)		Pump rpm	Gear Ratio	Motor rpm
100 psi	250 psi	500 psi	1000 psi			
36.49 (1/2)	36.12 (3/4)	35.21 (1)	33.25 (2)	30	60:1	1800
43.90 (1/2)	43.48 (3/4)	42.49 (1)	40.35 (2)	36	50:1	
55.00 (1/2)	54.53 (3/4)	53.39 (1)	51.17 (2)	45	40:1	
73.56 (1/2)	72.97 (3/4)	71.58 (1 1/2)	68.75 (3)	60	30:1	
88.41 (1/2)	87.71 (3/4)	86.12 (1 1/2)	82.81 (3)	72	25:1	
110.7 (1/2)	109.8 (1)	107.9 (1 1/2)	103.9 (3)	90	20:1	
147.8 (1/2)	146.7 (1)	144.3 (2)	139.1 (5)	120	15:1	
222.1 (1)	220.4 (1 1/2)	217.0 (3)	209.4 (5)	180	10:1	
296.3 (1)	294.1 (2)	289.8 (3)	279.7 (5)	240	7.5:1	
444.8 (1 1/2)	441.6 (3)	435.2 (5)	420.3 (7 1/2)	360	5:1	
593.3 (2)	589.0 (3)	580.7 (7 1/2)	560.9 (15)	480	7.5:1	3600
890.3 (3)	883.9 (5)	871.6 (10)	842.1 (15)	720	5:1	

*Capacity data shown is for pumps with elastomeric diaphragms. Consult factory for performance characteristics of pumps with PTFE diaphragms.

() Required Motor hp

Performance Maximum Flow at Designated Pressure - Metric *

All Pump Heads (lph)		Metallic Pump Heads (lph)		Pump rpm	Gear Ratio	Motor rpm
7 bar	17 bar	34 bar	69 bar			
115.1 (0.37)	113.9 (0.75)	111.1 (1.5)	104.9 (3)	25	60:1	1500
138.5 (0.37)	137.2 (0.75)	134.0 (1.5)	127.3 (3)	30	50:1	
173.5 (0.37)	172.0 (0.75)	168.4 (1.5)	161.4 (3)	37.5	40:1	
232.0 (0.37)	230.2 (0.75)	225.8 (1.5)	216.9 (3)	50	30:1	
278.9 (0.37)	276.7 (0.75)	271.7 (1.5)	261.2 (3)	60	25:1	
349.2 (0.55)	346.5 (0.75)	340.5 (1.5)	327.8 (3)	75	20:1	
466.3 (0.75)	462.7 (1.1)	455.2 (2.2)	438.6 (4)	100	15:1	
700.5 (0.75)	695.3 (1.5)	684.7 (3)	660.4 (5.5)	150	10:1	
934.7 (1.1)	927.9 (1.5)	914.1 (3)	882.2 (5.5)	200	7.5:1	
1403 (1.5)	1393 (2.2)	1373 (4)	1326 (7.5)	300	5:1	
1872 (1.5)	1858 (4)	1832 (5.5)	1769 (7.5)	400	7.5:1	3000
2808 (1.5)	2788 (4)	2750 (5.5)	2656 (7.5)	600	5:1	

*Capacity data shown is for pumps with elastomeric diaphragms. Consult factory for performance characteristics of pumps with PTFE diaphragms.

() Required Motor kW



Illinois Location:

(847) 841-7867
860 Church Rd Elgin, IL 60123

Minnesota Location:

(651) 758-7867
330 Mill Bay South Suite 1511 Afton, MN 55001

PumpSupplyInc.com

P600 Dimensions



P600 Models - F63

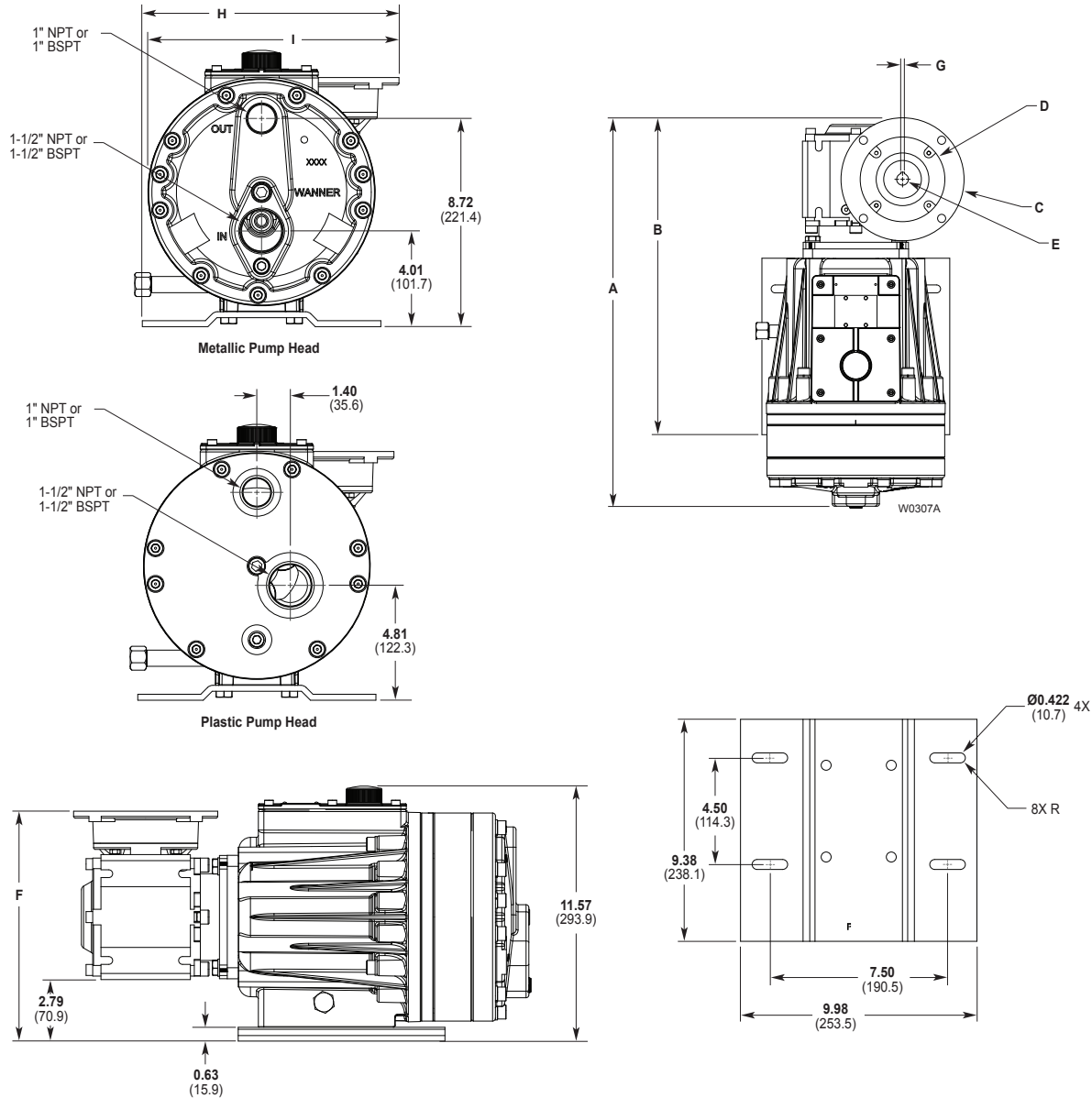

Dimensions in Inches (Millimeters)

Input Frame Size	A		B	C	D	E	F	G (Square Key)	H	I
	Metallic Pump Head	Plastic Pump Head								
NEMA 56C	20.64 (524.3)	21.56 (547.6)	16.84 (427.7)	Ø 6.54 (Ø 166)	Ø 4.50 (Ø 114.3)	Ø 0.62 (Ø 15.7)	10.43 (264.9)	0.187 (4.75)	10.74 (272.7)	10.49 (266.4)
NEMA 143/145 TC	20.64 (524.3)	21.56 (547.6)	16.84 (427.7)	Ø 6.54 (Ø 166)	Ø 4.50 (Ø 114.3)	Ø 0.87 (Ø 22.2)	10.90 (276.9)	0.187 (4.75)	10.74 (272.7)	10.49 (266.4)
NEMA 182/184 TC	21.95 (557.5)	22.88 (581.2)	18.16 (461.3)	Ø 9.17 (Ø 233)	Ø 8.50 (Ø 215.9)	Ø 1.12 (Ø 28.4)	12.03 (305.6)	0.25 (6.35)	12.06 (306.3)	11.81 (300)
IEC 63 B5	20.13 (511.3)	21.04 (534.4)	16.33 (414.8)	Ø 5.51 (Ø 140)	Ø 3.74 (Ø 95)	Ø 0.43 (Ø 11)	10.25 (260.4)	0.157 (4)	10.22 (259.6)	9.97 (253.3)
IEC 71 B5	20.52 (521.2)	21.44 (544.6)	16.72 (424.7)	Ø 6.30 (Ø 160)	Ø 4.33 (Ø 110)	Ø 0.55 (Ø 14)	10.25 (260.4)	0.196 (5)	10.62 (269.7)	10.37 (263.4)
IEC 80 B5	21.30 (541)	22.23 (564.7)	17.5 (444.5)	Ø 7.87 (Ø 200)	Ø 5.12 (Ø 130)	Ø 0.75 (Ø 19)	10.25 (260.4)	0.236 (6)	11.40 (289.6)	11.15 (283.3)
IEC 90 B5	21.30 (541)	22.23 (564.7)	17.5 (444.5)	Ø 7.87 (Ø 200)	Ø 5.12 (Ø 130)	Ø 0.94 (Ø 24)	10.25 (260.4)	0.314 (8)	11.40 (289.6)	11.15 (283.3)

P600 Dimensions (Cont'd)



P600 Models - F75

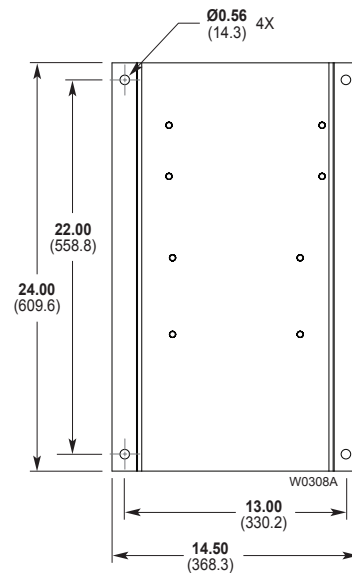
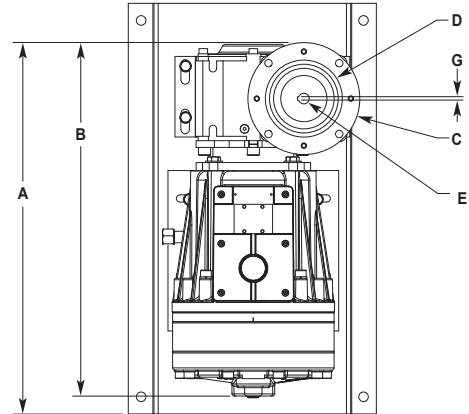
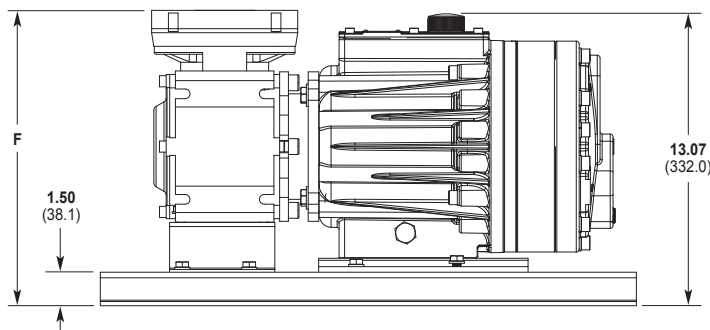
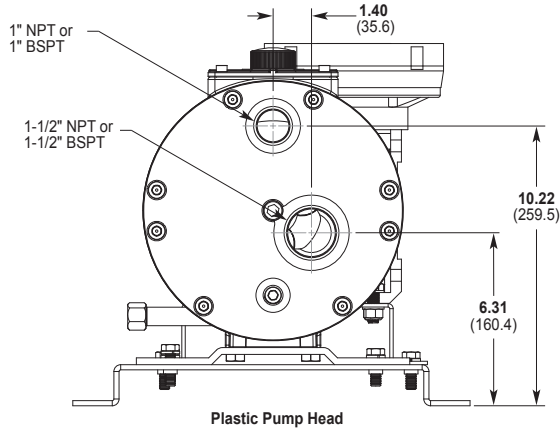
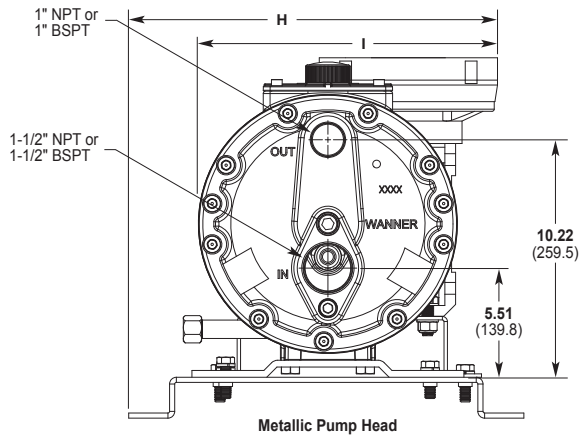

Dimensions in Inches (Millimeters)

Input Frame Size	A	B		C	D	E	F	G (Square Key)	H	I
		Metallic Pump Head	Plastic Pump Head							
NEMA 56C	21.70 (551.2)	20.70 (524.7)	21.57 (547.9)	Ø 6.54 (Ø 166)	Ø 4.50 (Ø 114.3)	Ø 0.62 (Ø 15.7)	13.22 (3.35.9)	0.187 (4.75)	13.53 (343.7)	10.97 (278.7)
NEMA 143/145 TC	21.70 (551.2)	20.70 (524.7)	21.57 (547.9)	Ø 6.54 (Ø 166)	Ø 4.50 (Ø 114.3)	Ø 0.87 (Ø 22.2)	13.22 (3.35.9)	0.187 (4.75)	13.53 (343.7)	10.97 (278.7)
NEMA 182/183 TC	23.01 (583.6)	22.01 (561.3)	22.11 (561.6)	Ø 9.17 (Ø 233)	Ø 8.50 (Ø 215.9)	Ø 1.12 (Ø 26.6)	13.77 (3.49.8)	0.250 (6.35)	14.84 (376.9)	12.29 (312.2)
IEC 71 B5	21.58 (548.3)	20.58 (522.7)	21.45 (544.8)	Ø 6.30 (Ø 160)	Ø 4.33 (Ø 110)	Ø 0.55 (Ø 14)	13.42 (340.7)	0.196 (5)	13.41 (340.6)	10.85 (275.6)
IEC 80 B5	22.36 (568.2)	21.36 (542.5)	21.16 (562.9)	Ø 7.87 (Ø 200)	Ø 5.12 (Ø 130)	Ø 0.75 (Ø 19)	13.42 (340.7)	0.236 (6)	14.20 (360.6)	11.63 (295.5)
IEC 90 B5	22.36 (568.2)	21.36 (542.5)	21.16 (562.9)	Ø 7.87 (Ø 200)	Ø 5.12 (Ø 130)	Ø 0.94 (Ø 24)	13.42 (340.7)	0.314 (8)	14.20 (360.6)	11.63 (295.5)
IEC 100/112 B14	21.58 (548.3)	20.58 (522.7)	21.45 (544.8)	Ø 6.30 (Ø 160)	Ø 4.33 (Ø 110)	Ø 1.10 (Ø 28)	13.42 (340.7)	0.314 (8)	13.41 (340.6)	10.85 (275.6)

P600 Installation



Location

Locate the pump as close to the supply source as possible.

Install the pump system in a lighted clean space where it will be easy to inspect and maintain.

Motor and Controller

The **P Series pump shaft** can rotate in either direction, therefore direction of motor shaft rotation is not critical.

Flow rate is determined by motor speed, which is controlled using an inverter duty constant torque motor and VFD. Flow rate functions can also be easily controlled using the Hydra-Cell Control Freak and appropriate motor.

Accessories

Consult installation drawing below for typical metering fluid system components. Contact Wanner Engineering or the distributor in your area for more details.



Illinois Location:

(847) 841-7867

860 Church Rd Elgin, IL 60123

Minnesota Location:

(651) 758-7867

330 Mill Bay South Suite 1511 Afton, MN 55001

PumpSupplyInc.com

Important Precautions

Adequate Fluid Supply. To avoid cavitation and premature pump failure, be sure that the pump will have an adequate fluid supply and that the inlet line will not be obstructed. See **Inlet Piping** on page 6.

Positive Displacement. This is a positive-displacement pump. To avoid severe system damage if the discharge line ever becomes blocked, install a relief valve downstream from the pump. See **Discharge Piping** on page 6.

Safety Guards. Follow all codes and regulations regarding installation and operation of the pumping system.

Shut-Off Valves. Never install shut-off valves between the pump and discharge pressure regulator, or in the regulator bypass line.

Consult the Factory for the following situations:

- Extreme temperature applications (above 160° F or below 40° F)
- Pressure feeding of pumps
- Viscous or abrasive fluid applications
- Chemical compatibility problems
- Hot ambient temperatures (above 110° F)

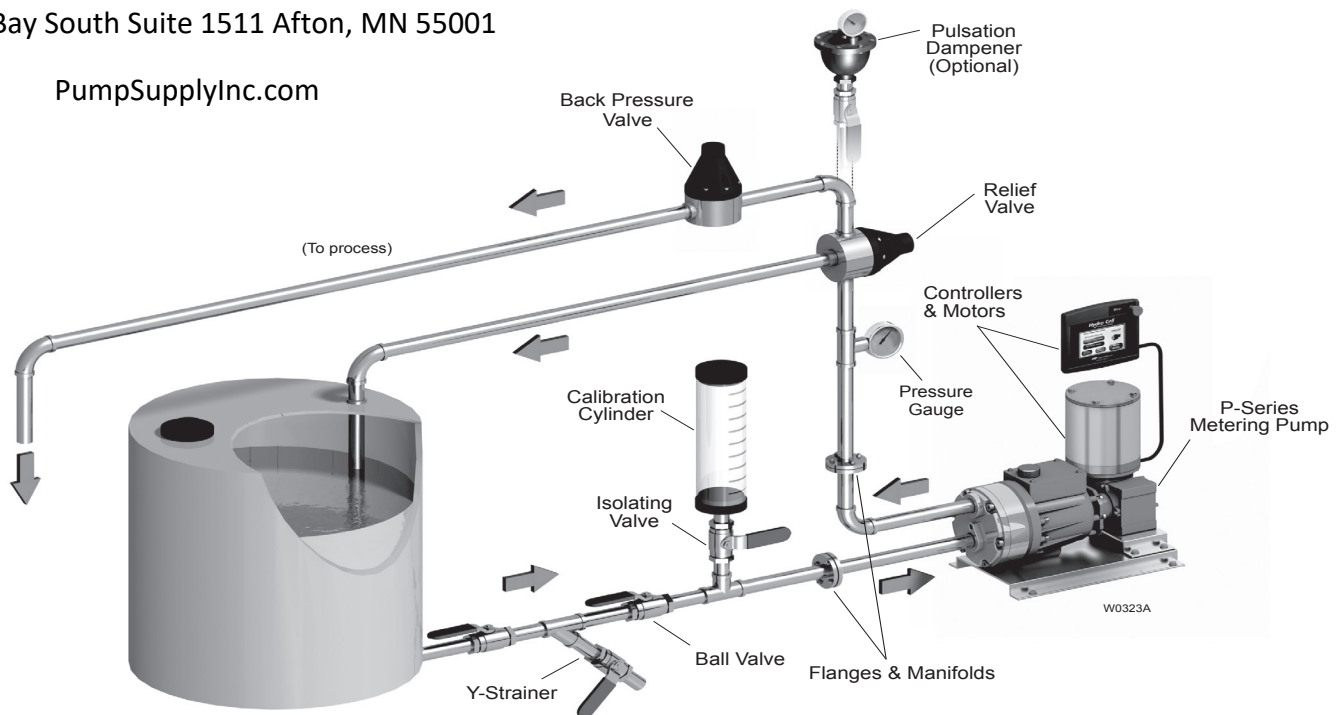

Typical Metering Installation

P600 Installation (Cont'd)



Safety Precautions

General remarks

These safety / installation instructions contain fundamental information and precautionary notes and must be kept available to all associated with the operation of the pump. Please read them thoroughly prior to installation, electrical connection and commissioning of the unit. It is imperative that all other operating instructions relating to the components of individual units are followed.

These safety / installation instructions do not take local regulations into account. The operator must ensure that such regulations are observed by all, including the personnel carrying out the installation.

Each pump must be labeled by the end user to warn of any hazards that the system process may produce; e.g. corrosive chemicals or hot process etc.

All personnel involved in the operation, maintenance, inspection and installation of the pump must be fully qualified to carry out the work. The personnel's responsibilities, competence and supervision must be clearly defined by the operator. To the extent that if the personnel in question is not already in possession of the requisite know how, appropriate training and instruction must be provided. In addition, the operator is responsible for ensuring that the contents of the operating instructions are fully understood by all the responsible personnel.

When installing a Hydra-Cell pump in conjunction with a motor or motor and frequency controller the relevant manuals must be referred to for electromagnetic compatibility. The installation should conform to EN 61800 and EN 60204 as applicable.

All safety instructions in this manual and all relevant local health and safety regulations must be followed.

Attention must be paid to the weight of the pump before attempting to lift either manually or selecting appropriate lifting equipment.

Inlet Piping

Provide for permanent or temporary installation of a compound pressure gauge to monitor the inlet pressure. To maintain maximum flow, the pump inlet should be under flooded suction conditions at all times. **Do not supply more than one pump from the same inlet line.**

Supply Tank

Use a supply tank that is large enough to provide time for any trapped air in the fluid to escape. The tank size should be at least twice the maximum pump flow rate.

Install a separate inlet line from the supply tank to each pump.

Place a cover over the supply tank, to prevent foreign objects from falling into it.

Hose Sizing and Routing

To minimize acceleration head and frictional losses, size the suction line at least one size larger than the pump inlet, and keep the suction line as short and direct as possible.

Recommendations:

- Keep inlet lines less than 3 ft. (1 m) long
- Use at least 1-1/2" (38 mm) I.D. inlet hose
- Minimize fittings (elbows, valves, tees, etc.)

Inlet Piping (Pressure Feed)

Provide for permanent or temporary installation of a pressure gauge to monitor the inlet pressure. Pressure at the pump inlet should not exceed 250 psi (17 bar); if it could get higher, install a pressure reducing valve. **Do not supply more than one pump from the same inlet line.**

Note: System back pressure must exceed the pump inlet pressure by at least 15 psi (1 bar) in order to prevent flow thru.

Discharge Piping

Hose and Routing

Use the shortest, most-direct route for the discharge line.

Select pipe or hose with a **working pressure** rating of at least 1.5 times the maximum system pressure. EXAMPLE: Select a 1500 psi (103 bar) W.P.-rated hose for systems to be operated at 1000 psi (69 bar) gauge pressure.

Support the pump and piping independently.

Pressure Regulation

Install a pressure relief valve in the discharge line. Bypass pressure must not exceed the pressure limit of the pump.

Size the valve so that, when fully open, it will be large enough to relieve the full capacity of the pump without over-pressurizing the system.

Locate the valve as close to the pump as possible and ahead of any other valves.

Adjust the pressure relief valve to no more than 10% over the maximum working pressure of the system. Do not exceed the manufacturer's pressure rating for the pump or valve.

Route the bypass line to the supply tank.

CAUTION: Never install shutoff valves in the bypass line or between the pump and pressure regulator or relief valve.

Provide for permanent or temporary installation of a pressure gauge to monitor the discharge pressure at the pump.

Minimum Discharge Pressure

To ensure proper capacity control, a minimum discharge pressure of 50 psi (3.5 bar) is required.

P600 Installation (Cont'd)



Initial Start-Up Procedure

Before you start pump, be sure that:

- All shut-off valves are open, and the pump has an adequate supply of fluid.
 - All connections are tight.
 - The oil level is 1/4 inch (6 mm) above the cast surface in the upper oil reservoir.
1. Open priming valve on system back pressure valve so pump starts under minimum pressure.
 2. Turn on power to pump motor.
 3. Check inlet pressure or vacuum. To maintain maximum flow, pump inlet should be under flooded suction conditions at all times. Inlet pressure must not exceed 250 psi (17 bar).
 4. Listen for any erratic noise and look for unsteady flow.
 - Jog pump on and off until fluid coming from priming valve is air-free.
 - Close priming valve.

Calibration

Note: Each metering pump or pump system must be calibrated to determine the pump speed required for the desired flow rate.

Accurate calibration depends on pump discharge pressure and system conditions. When calibrating the pump or system, it is useful to plot capacity curves for future reference. Observe on the curve, that pump capacity decreases slightly as discharge pressure increases.

In order to achieve the best possible results, perform calibration under actual process conditions. Follow these steps:

1. Run pump for 20 minutes at actual process conditions. If process system cannot be used, circulate back to supply tank through pressure relief valve (see Typical Metering Installation drawing). If required system pressure is less than 50 psi (3.5 bar) back pressure valve must be installed and set to produce minimum of 50 psi (3.5 bar) pressure at pump head.
2. Determine maximum pump speed required for all system conditions that need to be satisfied. Measure pump delivery at this maximum speed using system calibration cylinder, flow meter, or similar container. This is the "rated capacity" for pump.
3. Measure pump delivery at 100%, 75%, 50%, 25%, and 10% of maximum speed just determined. Let pump run for 5 minutes at each speed setting before taking capacity measurement.



Illinois Location:

(847) 841-7867

860 Church Rd Elgin, IL 60123

Minnesota Location:

(651) 758-7867

330 Mill Bay South Suite 1511 Afton, MN 55001

PumpSupplyInc.com



P600 Maintenance

Note: The numbers in parentheses are Reference Numbers located in the Parts List exploded views of this manual.

Periodically

CAUTION: Do not turn the drive shaft while the oil reservoir is empty.

CAUTION: Do not leave contaminated oil in the pump housing or leave the housing empty. Remove contaminated oil as soon as discovered and replace with clean oil.

1. Check inlet pressure periodically with gauge.
2. Change oil according to hours guidelines in table.
3. Change oil as follows:
 - a. Remove brass cap (34), and allow oil and contaminants to drain completely. Catch oil and dispose of properly.
 - b. Use suitable Hydra-Oil for the application and pump components.

Pump Operation Hours Between Oil Changes at Various Process Fluid Temperatures

Pressure	<90°F (32°C)	<139°F (60°C)	<180°F (82°C)
Metallic Pump Head			
<650 psi (45 bar)	6,000	4,500	3,000
<1000 psi (70 bar)	4,000	3,000	2,000
Non-Metallic Pump Head			
<250 psi (17 bar)	4,000	3,000	—

Note: Minimum oil viscosity for proper hydraulic end lubrication is 16-20 cST (80-100 SSU). P-Series replacement parts kits (complete kits and diaphragm kits) include suitable oil for each P Series pump configuration.

CAUTION: If you are losing oil but don't see any external leakage, or if the oil becomes discolored and contaminated, the diaphragm (22) may be damaged. Refer to the Fluid End Service and Troubleshooting Sections. Do not operate the pump with a damaged diaphragm.



Illinois Location:

(847) 841-7867

860 Church Rd Elgin, IL 60123

Minnesota Location:

(651) 758-7867

330 Mill Bay South Suite 1511 Afton, MN 55001

PumpSupplyInc.com

P600 Fluid End Service



Note: The reference numbers in parentheses are shown in the Fluid End Parts List.

This section explains how to disassemble and inspect all easily-serviceable parts of the pump fluid end.

CAUTION: Disassembly of the hydraulic end of the pump should be performed only by a qualified technician. For assistance, contact Wanner Engineering (612-332-5681) or the distributor in your area.

CAUTION: The four bolts (26) that screw through the back of the housing into the cylinder casting hold the casting over the hydraulic end of the pump. Do not remove them except when repairing the hydraulic end.

1. Remove Manifold (7), Valve Plate (18)

- Remove all bolts (5) around manifold (7). Do not remove four bolts (26) installed through back of pump housing.
- With 3/8 in. (10 mm) hex Allen wrench, remove center bolt (1) and washer (2) in center of manifold.

CAUTION: Do not turn the pump drive shaft while the manifold and valve plate are off the pump, except when removing diaphragms or repriming the hydraulic cells.

- Remove manifold (7) and support plate (43). (Support plate (43) is used only with non-metallic pump head.)
- Inspect manifold for warping or wear around inlet and outlet ports. If wear is excessive, replace manifold. To check if manifold is warped, remove O-rings and place straightedge across it. A warped manifold should be replaced.
- Remove three socket-head cap screws (39) with 3/16 in. (5 mm) hex Allen wrench.
- Inspect valve plate (18) in same manner as manifold.

Note: Plastic valve plates and manifolds should also be inspected for cracks, and replaced if necessary.

2. Inspect Valves (11-16, 38)

The three inlet and three outlet valve assemblies are identical but face in opposite directions. Inspect each valve as follows:

- Check spring retainer (16), and replace if worn. **Note: if your pump has a non-metallic pump head there will be a plastic dampening washer (38) at the bottom of each seat. Inspect each one for wear or cracks and replace if necessary.**
- Check valve spring (14). If shorter than new spring, replace (**Do not stretch old spring.**)
- Check valve (13). If worn excessively, replace.

Note: If your pump has plastic spring retainers, there is a tetra seal (flat O-ring, 15) between the retainer (16) and valve seat (12).

- Remove valve seat (12) and O-ring (11). A seat remover is included in Wanner Tool Kit. On cast iron valve plates, be careful not to break metal ridge around O-ring groove. Inspect valve seat for wear, and replace if necessary. A new O-ring should be installed.
- Reinstall the inlet and outlet valve assemblies:
 - Clean valve ports and shoulders with emery cloth, and lubricate with lubricating gel or petroleum jelly.
 - Install O-ring (11) on valve seat (12).
 - Inlet Valves (3 center valves in illustration below).** Insert spring retainer (16) into valve plate (18). Then insert spring (14), valve (13), and valve seat (12). If pump has plastic spring retainers, install flat Tetra seal O-ring (15) between spring retainer and valve seat. Insert dampening washer (38), if included in your valve assembly.
 - Outlet Valves (3 outer valves in illustration below).** Insert dampening washer (38), if included in your valve assembly. Insert valve seat (12), valve (13), spring (14), and spring retainer (16). If pump has **plastic** spring retainers, install flat Tetra seal O-ring (15) between spring retainer and valve seat. If pump has **metal** spring retainers in outlet valves, position them so leg does not point toward center of pump (See illustration below.)

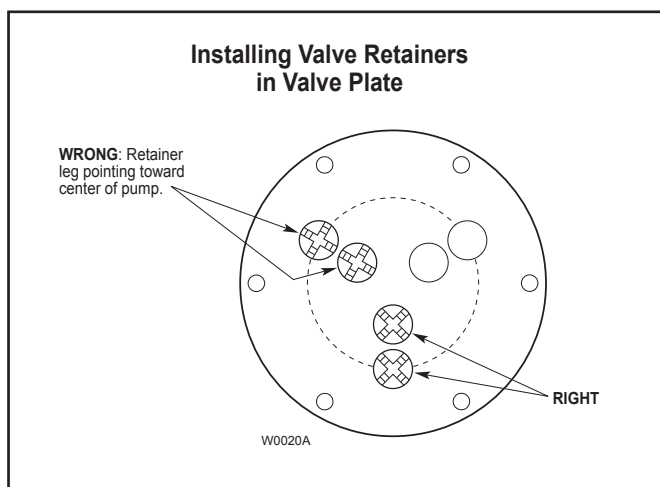

Illinois Location:

(847) 841-7867

860 Church Rd Elgin, IL 60123

Minnesota Location:

(651) 758-7867

330 Mill Bay South Suite 1511 Afton, MN 55001

PumpSupplyInc.com

P600 Fluid End Service (Cont'd)

3. Inspect and Replace Diaphragms (22)

If necessary to service diaphragms, remove two socket-head cap screws (39) that secure valve plate (18) to cylinder casting (25). Inspect valve plate the same as manifold in Paragraph 1, step d.

- Lift diaphragm (22) by one edge, and turn pump shaft (**use the shaft rotator from the Wanner Tool Kit**) until diaphragm pulls up. This will expose machined cross holes in valve plunger shaft behind diaphragm.
- Insert plunger holder (**from the Wanner Tool Kit**) through one of machined cross holes to hold diaphragm up. Don't remove tool until new diaphragm is installed in step f below.
- Remove screw (19), O-ring (20), and follower (21) in center of diaphragm (22).
- Remove diaphragm and inspect diaphragm carefully. A damaged diaphragm generally indicates a pumping system problem. Replacing diaphragm only, will not solve the larger problem. Inspect diaphragm for following:
 - **Puncture.** Usually caused by sharp foreign object in fluid.
 - **Diaphragm pulled away** from center screw or from cylinder sides. Usually caused by fluid being frozen in pump, or by over-pressurization of pump.
 - **Diaphragm becoming stiff** and losing flexibility. Usually caused by pumping fluid that is incompatible with diaphragm material.
 - **Diaphragm edge chewed away.** Usually caused by over-pressurizing system.
- Inspect plunger (23) for any rough surfaces or edges. **Do not** remove plunger from plunger shaft. Smooth surfaces and edges as necessary with emery cloth or fine file.

CAUTION: If a diaphragm has ruptured and foreign material or water has entered the oil reservoir, do not operate the pump. Check all diaphragms, then flush the reservoir completely (as outlined below) and refill it with fresh oil. Never let the pump stand with foreign material or water in the reservoir, or with the reservoir empty.
- Install new diaphragm (22) (or old one, if not damaged), ridge side out.
- Clean screw (19) and remove any oil from it. Apply medium-strength thread locker to screw. Reinstall screw, follower (21), and new O-ring (20). Tighten to 18 in-lbs (2.0 N-m).
- Repeat above inspection procedure (and replacement, if necessary) with other two diaphragms.

4. Flush Contaminant from Hydraulic End

(Only if a diaphragm has ruptured)

- Remove oil drain cap (34) and allow all oil and contaminant to drain out.
- Fill reservoir with compatible solvent. Manually turn pump shaft to circulate compatible solvent and drain. Use the shaft rotator provided in Wanner Tool Kit (Part No. A03-175-1102). Dispose of contaminated fluid properly.

CAUTION: If you have an EPDM diaphragm, or if food grade oil is in the reservoir, do not use kerosene or solvents. Instead, flush with the same lubricant that is in the reservoir.
- Repeat step b. flushing procedure.
- Fill reservoir with fresh oil, manually turn pump shaft to circulate oil. Drain oil.

Note: P Series replacement parts kits (complete kits and diaphragm kits) include the correct oil for each specific P Series pump configuration.
- Refill reservoir with fresh oil. If oil appears milky, there is still contaminant in reservoir. Repeat steps c and d until oil appears clean.

5. Priming Hydraulic Cells

Note: Providing oil prime to fitted pumps requires pressure be applied to the diaphragms. This can be done manually, with the system head pressure, or with pressurized air if available. Review all methods below to determine the procedure most suitable.

Method 1 (system head pressure less than 2 psi)

- Install valve plate (18) without outlet valves installed (or else remove outlet valves; leave seats installed) on cylinder housing. Tighten three socket-head screws (39).
- Fill reservoir with appropriate Hydra-oil to fill port.

Note: P Series replacement parts kits (complete kits and diaphragm kits) include the correct oil for each specific P Series pump configuration.
- With blunt pointer (eraser end of pencil), reach in through each outlet valve port and push diaphragm (22) backwards. Note air bubbles coming out at oil fill port. Now turn shaft about 1/2 turn.
- Repeat depressing diaphragms and rotating shaft (approximately 4 to 6 times) until no more air bubbles escape and oil has dropped about 1 inch (25 mm) from top of fill port. Hydraulic cells are now primed. Replace oil fill cap (28) and O-ring (27).
- Install outlet valve assemblies in each outlet valve port. See Parts list for correct assembly order. If necessary, tip pump (head upward) to keep valve (13) centered on valve seat (12) and allow valve retainer (16) to fit flush with port.
- Install manifold (7) and complete installation.



P600 Fluid End Service (Cont'd)

5. Priming Hydraulic Cells (Cont'd)

Alternative Method 1 (system head pressure less than 2 psi)

- a. With pump horizontal, and the fluid-end head removed, fill reservoir with correct Hydra-oil to fill port.

Note: P Series replacement parts kits (complete kits and diaphragm kits) include the correct oil for each specific P Series pump configuration.

- c. Have catch basin for oil that leaks from behind diaphragms when priming. Catch oil and dispose of properly. **Do not reuse oil.**
- c. All air in oil within hydraulic piston behind diaphragms (22) must be forced out by turning shaft (and pumping piston). A shaft rotator is included in the Hydra-Cell Tool Kit. Keep pressure on diaphragms while turning shaft until bubble-free flow of oil comes from behind all diaphragms. Maintain oil level in reservoir. Do not allow oil level to be lower than reservoir.
- d. Quickly attach loaded valve plate (18) (before oil runs out past diaphragms) with socket head screws (39), but do not tighten completely. Leave gap between valve plate and the cylinder housing (25). Turn shaft 2-3 turns to finish forcing out air behind diaphragms. Hydraulic cells are now primed. Finish tightening valve plate with two socket head screws and add pump manifold (7).
- e. Wipe excess oil from around pump head.
- f. Check that oil level is 1 inch (25 mm) from top of fill port.
- g. Replace oil fill cap (28) and O-ring (27) and complete installation.

Method 2 (head pressure greater than 2 psi)

This simple and clean method of priming Hydra-cells requires an inlet head pressure of at least 5 feet (1.5 m) or 2 psi (.14 bar). The pressure source is required to hold the diaphragms back while the piston moves so as to force out the air.

- a. Completely assemble pump and fill reservoir with correct Hydra-oil to fill port.

Note: P Series replacement parts kits (complete kits and diaphragm kits) include the correct oil for each specific P Series pump configuration.

- b. **When tank head pressure is being used to prime**, install pump back into system and connect tank supply line to pump inlet. Pump discharge line may be connected at this time, but end of line must be open to allow air to pass out.
- c. Slowly turn pump shaft by hand and watch for bubbles exiting oil reservoir fill opening. This will take several rotations; when no more bubbles come out and reservoir level has dropped about 1" (25 mm), hydraulic cells are primed.
- d. Replace oil fill cap (28) and O-ring (27) and complete installation.

- e. **When compressed air is being used to prime**, insert clean air hose to pump inlet and restrict pump outlet. Turn shaft quarter turn and then apply air pressure into manifold to put pressure on diaphragms (22). This will force air out from inside pistons. Observe see bubbles at reservoir opening. Repeat for several rotations until no more air bubbles come out and reservoir level has dropped about 1" (25 mm). Hydraulic cells are now primed.
- f. Replace oil fill cap (28) and O-ring (27) and complete installation.

6. Reinstall Valve Plate (18), Manifold (7)

Note: Use the cap screw (26) protruding through the cylinder casting at the 10 o'clock position to locate the valve plate on the cylinder casting. Place the "blind hole" on the valve plate over this bolt.

- a. With valve assemblies installed as outlined above, reinstall valve plate (18) onto cylinder housing (25). Recheck that blind hole is over protruding bolt at 10 o'clock position. Install two socket-head cap screws (39) and secure valve plate to cylinder casting.
- b. Reinstall O-rings (8,9,10) on rear side of the manifold (7). Use petroleum jelly or lubricating gel to hold them in place.
- c. Reinstall manifold onto valve plate. Be sure drain plug (4) is installed in manifold.

Note: on pumps with non-metallic head, position support plate (43) onto manifold with ports and bolt holes aligned correctly.

- d. Insert bolts (5) and washers (6). Hand tighten.
- e. Reinstall center bolt (1) with washer (2), and torque to 45 ft-lbs (60 N-m).
- f. Alternately tighten six perimeter bolts (5). Torque to 45 ft-lbs (60 N-m).
- g. Recheck all bolts for tightness.



Illinois Location:

(847) 841-7867

860 Church Rd Elgin, IL 60123

Minnesota Location:

(651) 758-7867

330 Mill Bay South Suite 1511 Afton, MN 55001

PumpSupplyInc.com



P600 Fluid End Parts, metal

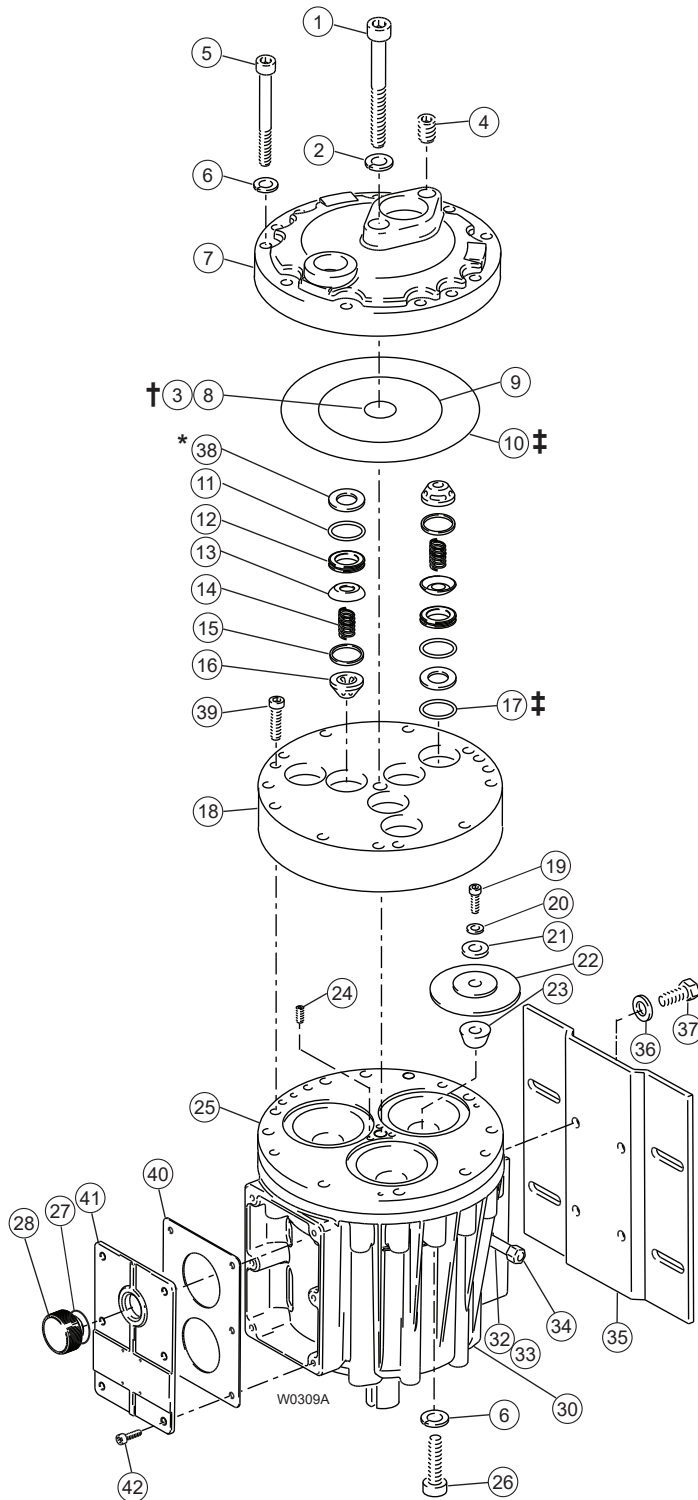

Valve Assemblies with metal spring retainers

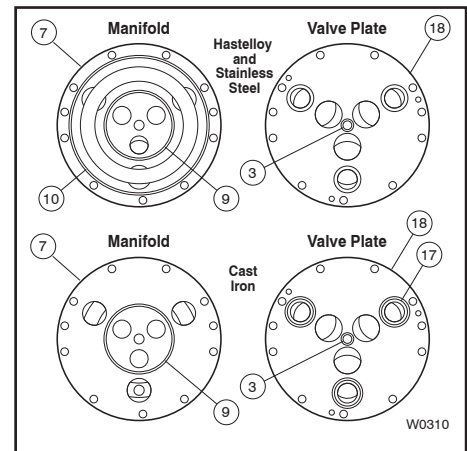
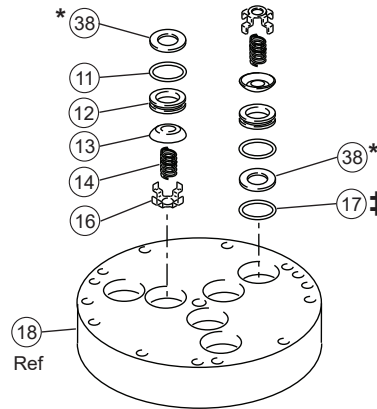

† With brass external-centerbolt models, use #8; with all other models, use #3.

‡ With cast iron pump heads, use #17 and not #10; with all other heads, use #10 and not #17.

* Not included with brass pump heads.

Ref. No.	Part Number	Description	Quantity/ Pump
1	G25-081-2019	Screw, Cap, soc-hd, SST	1
2	G10-084-1010	Washer, Flat, SST	1
3	D25-083-2110	O-ring, Centerbolt, Buna-N	1
	D25-083-2111	O-ring, Centerbolt, FKM	1
	D25-083-2112	O-ring, Centerbolt, Neoprene	1
	D25-083-2113	O-ring, Centerbolt, EPDM	1
	D25-083-2118	O-ring, Centerbolt, PTFE	1
4	D25-038-2017	Plug, Hastelloy C, NPT	1
	D25-038-2211	Plug, 316 SST, NPT	1
	G25-038-2017	Plug, Hastelloy C, BSPT	1
	G25-038-2211	Plug, 316 SST, BSPT	1
5	G25-024-2019	Screw, Cap, soc-hd, SST	11
6	G25-048-2012	Washer, Split lock, SST	25

P600 Fluid End Parts, metal (Cont'd)

Ref. No.	Part Number	Description	Quantity/ Pump	Ref. No.	Part Number	Description	Quantity/ Pump
7	D25-004-1010	Manifold, Brass, NPT	1	18	D25-003-1010	Valve Plate, Brass	1
	D25-004-1022	Manifold, 316 SST, NPT	1		D25-003-1012	Valve Plate, 316 SST	1
	D25-004-1026	Manifold, Cast iron, NPT	1		D25-003-1016	Valve Plate, Cast iron	1
	D25-004-1029	Manifold, Hastelloy C, NPT	1		D25-003-1029	Valve Plate, Hastelloy C	1
	D25-004-1081	Manifold, ANSI flange, 150 x 600	1	19	D25-030-2010	Screw, Flat-hd, 316 SST	3
	G25-004-1010	Manifold, Brass, BSPT	1		D25-030-2011	Screw, Flat-hd, Hastelloy C	3
	G25-004-1022	Manifold, 316 SST, BSPT	1	20	D25-047-2110	O-ring, Follower, Buna-N	3
	G25-004-1026	Manifold, Cast iron, BSPT	1		D25-047-2111	O-ring, Follower, FKM	3
	G25-004-1029	Manifold, Hastelloy C, BSPT	1		D25-047-2112	O-ring, Follower, Neoprene	3
8	D10-083-2110	O-ring, center manifold, Buna-N(1)	1		D25-047-2113	O-ring, Follower, EPDM	3
	D10-083-2111	O-ring, center manifold, FKM(1)	1		D25-047-2118	O-ring, Follower, PTFE	3
	D10-083-2112	O-ring, center manifold, Neoprene(1)	1	21	D25-017-1010	Follower, 316 SST	3
	D10-083-2113	O-ring, center manifold, EPDM(1)	1		D25-017-1011	Follower, Hastelloy C	3
	D10-083-2118	O-ring, center manifold, PTFE(1)	1	22	D25-018-2312	Diaphragm, Neoprene	3
9	D25-073-2110	O-ring, Inner manifold, Buna-N	1		D25-018-2313	Diaphragm, EPDM	3
	D25-073-2111	O-ring, Inner manifold, FKM	1		D25-018-2315	Diaphragm, FKM	3
	D25-073-2112	O-ring, Inner manifold, Neoprene	1		D25-018-2318	Diaphragm, PTFE	3
	D25-073-2113	O-ring, Inner manifold EPDM	1		D25-018-2320	Diaphragm, Buna-N	3
	D25-073-2118	O-ring, Inner manifold, PTFE	1		D25-018-2325	Diaphragm, Aflas	3
	(Use on Brass, SST and Hastelloy Pump Heads only) ..			23	D25-016-1010	Plunger	3
10	D25-097-2110	O-ring, Outer manifold, Buna-N	1	24	G25-082-2010	Set Screw	3
	D25-097-2111	O-ring, Outer manifold, FKM	1	25	K25-002-1220	Cylinder Housing Assembly(2)	1
	D25-097-2112	O-ring, Outer manifold Neoprene	1		K25-002-1020	Cylinder Housing	1
	D25-097-2113	O-ring, Outer manifold EPDM	1	26	H25-087-2020	Screw, Cap, soc-hd, SST	4
	D25-097-2118	O-ring, Outer manifold, PTFE	1	27	D10-080-2110	O-ring, Buna-N	1
11	D25-035-2110	O-ring, Valve seat, Buna-N	6	28	D03-039-1030	Cap with O-ring, Oil fill	1
	D25-035-2111	O-ring, Valve seat, FKM	6	30	H25-001-1233	Pump Housing, HCMS	1
	D25-035-2112	O-ring, Valve seat, Neoprene	6	31	G10-028-2011	Nut, Hex-hd, SST	10
	D25-035-2113	O-ring, Valve seat, EPDM	6	32	D25-076-2210	Elbow, 3/8"	1
	D25-035-2118	O-ring, Valve seat, PTFE	6	33	D25-077-2210	Pipe, 3/8"	1
12	D25-020-1012	Valve Seat, Nitronic 50	6	34	D25-078-2210	Cap, 3/8"	1
	D25-020-1016	Valve Seat, Tungsten carbide	6	35	D25-025-1033	Base	1
	D25-020-1017	Valve Seat, Hastelloy C	6	36	G25-054-2010	Washer, Shakeproof, M10	4
	D25-020-3300	Valve Seat, Ceramic	6	37	G10-029-2010	Screw, Cap, hex-hd	4
13	D25-021-1011	Valve, Nitronic 50	6	38	D25-125-1017	Washer, Dampening, Hastelloy C	6
	D25-021-1016	Valve, Tungsten carbide	6	39	G25-088-2010	Screw, Cap, soc-hd	3
	D25-021-1017	Valve, Hastelloy C	6	40	G25-106-2318	Gasket, Cover	1
	D25-021-3300	Valve, Ceramic	6	41	H25-105-1018	Housing cover	1
14	D25-022-3114	Valve Spring, Elgiloy	6	42	G25-090-2010	Screw, Cap, hex-hd	6
	D25-022-3115	Valve Spring, Hastelloy C	6				
15	D25-092-2110	Tetra Seal, Buna-N	6				
	D25-092-2111	Tetra Seal, FKM	6				
	D25-092-2112	Tetra Seal, Neoprene	6				
	D25-092-2113	Tetra Seal, EPDM	6				
	D25-092-2118	O-ring, PTFE	6				
16	D25-023-1017	Retainer, Valve spring, Hastelloy C	6				
	(Use on Cast Iron Pumping Heads only)						
17	D25-074-2110	O-ring, Outlet valve, Buna-N	3				
	D25-074-2111	O-ring, Outlet valve, FKM	3				
	D25-074-2112	O-ring, Outlet valve, Neoprene	3				
	D25-074-2113	O-ring, Outlet valve, EPDM	3				
	D25-074-2118	O-ring, Outlet valve, PTFE	3				

(1) With brass extenal-centerbolt models, use item 8; with all other models, use item 3.

(2) Cylinder Housing Assembly includes: cylinder housing (25), bearing adjusting plate (61), O-ring (60), screws (24), and bearing cup (62A).



P600 Fluid End Parts, non-metal

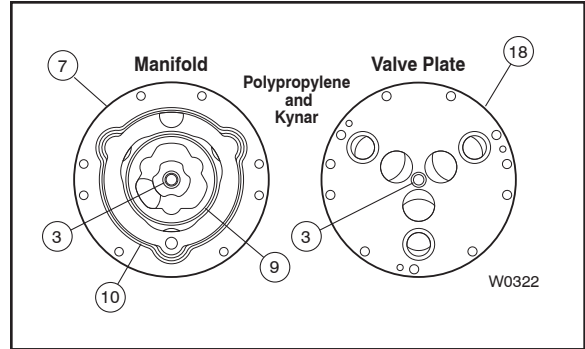
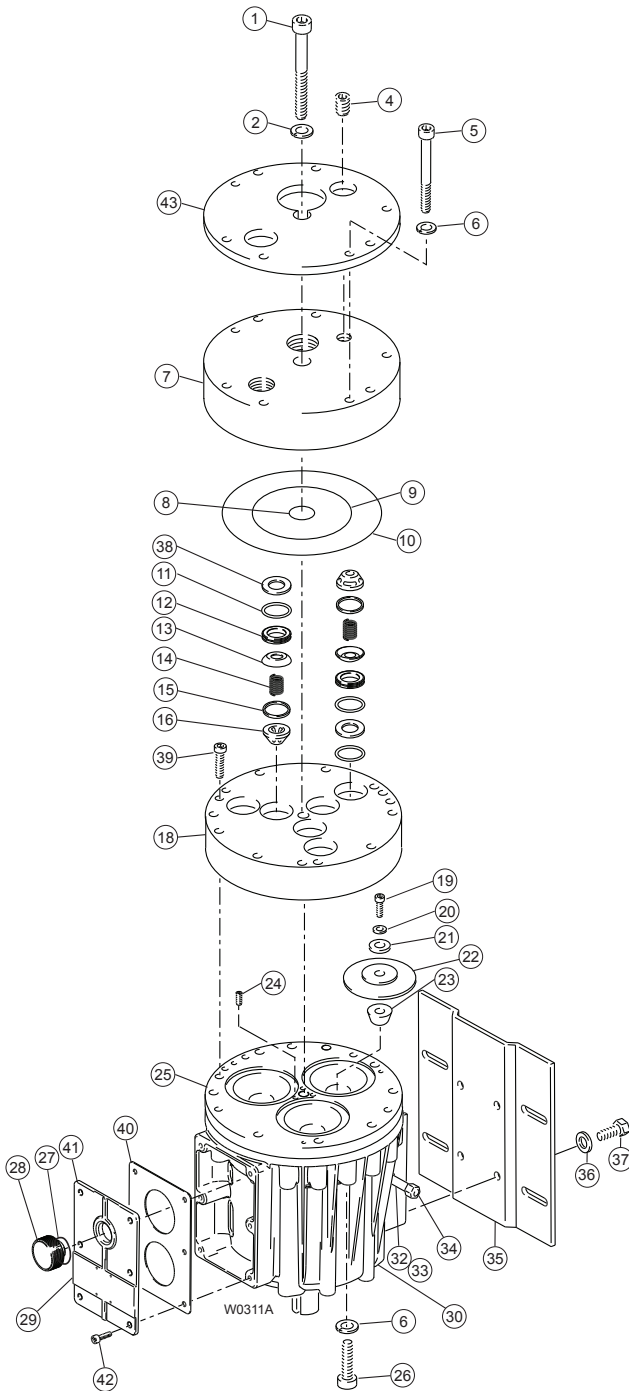

Ref. No.	Part Number	Description	Quantity/ Pump
1	G25-081-2018	Screw, Cap, soc-hd, SST	1
2	G10-084-1010	Washer, Flat, SST	1
4	D25-038-2017	Plug, Hastelloy C, NPT	1
	D25-038-2211	Plug, 316 SST, NPT	1
	G25-038-2017	Plug, Hastelloy C, BSPT	1
	G25-038-2211	Plug, 316 SST, BSPT	1
5	G25-024-2018	Screw, Cap, hex-hd, SST	8
6	G25-048-2012	Washer, Split lock, SST	16
7	D25-004-1054	Manifold, Polypropylene, NPT	1
	D25-004-1057	Manifold, PVDF, NPT	1
	G25-004-1054	Manifold, Polypropylene, BSPT	1
	G25-004-1057	Manifold, PVDF, BSPT	1
8	D10-083-2110	O-ring, Center manifold, Buna-N	1
	D10-083-2111	O-ring, Center manifold, FKM	1
	D10-083-2112	O-ring, Center manifold, Neoprene	1
	D10-083-2113	O-ring, Center manifold, EPDM	1
	D10-083-2118	O-ring, Center manifold, PTFE	1
9	D25-073-2110	O-ring, Inner manifold, Buna-N	1
	D25-073-2111	O-ring, Inner manifold, FKM	1
	D25-073-2112	O-ring, Inner manifold, Neoprene	1
	D25-073-2113	O-ring, Inner manifold, EPDM	1
	D10-073-2118	O-ring, Inner manifold, PTFE	1
10	D25-109-2110	O-ring, Outer manifold, Buna-N	1
	D25-109-2111	O-ring, Outer manifold, FKM	1
	D25-109-2112	O-ring, Outer manifold, Neoprene	1
	D25-109-2113	O-ring, Outer manifold, EPDM	1
	D25-109-2118	O-ring, Outer manifold, PTFE	1

P600 Fluid End Parts, non-metal (Cont'd)

Ref. No.	Part Number	Description	Quantity/ Pump
11	D25-035-2110	O-ring, Valve seat, Buna-N	6
	D25-035-2111	O-ring, Valve seat, FKM	6
	D25-035-2112	O-ring, Valve seat, Neoprene	6
	D25-035-2113	O-ring, Valve seat, EPDM	6
	D25-035-2118	O-ring, Valve seat, PTFE	6
12	D25-020-1012	Valve seat, Nitronic 50	6
	D25-020-1016	Valve Seat, Tungsten carbide	6
	D25-020-1017	Valve seat, Hastelloy C	6
	D25-020-3300	Valve seat, Ceramic	6
13	D25-021-1011	Valve, Nitronic 50	6
	D25-021-1016	Valve, Tungsten carbide	6
	D25-021-1017	Valve, Hastelloy C	6
	D25-021-3300	Valve, Ceramic	6
14	D25-022-3114	Valve Spring, Elgiloy	6
	D25-022-3115	Valve Spring, Hastelloy C	6
15	D25-092-2110	Tetra Seal, Buna-N	6
	D25-092-2111	Tetra Seal, FKM	6
	D25-092-2112	Tetra Seal, Neoprene	6
	D25-092-2113	Tetra Seal, EPDM	6
	D25-092-2118	O-ring, PTFE	6
16	D25-023-2317	Retainer, Valve spring, polypropylene	6
	D25-023-2318	Retainer, Valve spring, PVDF	6
18	D25-003-1050	Valve plate, Polypropylene	1
	D25-003-1053	Valve plate, PVDF	1
19	D25-030-2010	Screw, Flat-hd, 316 SST	3
	D25-030-2011	Screw, Flat-hd, Hastelloy C	3
20	D25-047-2110	O-ring, Follower, Buna-N	3
	D25-047-2111	O-ring, Follower, FKM	3
	D25-047-2112	O-ring, Follower, Neoprene	3
	D25-047-2113	O-ring, Follower, EPDM	3
	D25-047-2118	O-ring, Follower, PTFE	3
21	D25-017-1010	Follower, 316 SST	3
	D25-017-1011	Follower, Hastelloy C	3
22	D25-018-2312	Diaphragm, Neoprene	3
	D25-018-2313	Diaphragm, EPDM	3
	D25-018-2315	Diaphragm, FKM	3
	D25-018-2320	Diaphragm, Buna-N	3
	D25-018-2318	Diaphragm, PTFE	3
	D25-018-2325	Diaphragm, Aflas	3
23	D25-016-1010	Plunger	3
24	G25-082-2010	Set Screw	3
25	K25-002-1210	Cylinder Housing Assembly(1)	1
	K25-002-1020	Cylinder Housing	1
26	H25-087-2020	Screw, Cap, soc-hd, SST	4
27	D10-080-2110	O-ring, Buna-N	1
28	D03-039-1030	Cap, Oil fill (includes breather and O-ring)	1
29	D10-040-2420	Nameplate	1
30	H25-001-1233	Pump Housing	1

Ref. No.	Part Number	Description	Quantity/ Pump
31	G10-028-2011	Nut, Hex-hd, SST	8
32	D25-076-2210	Elbow, 3/8"	1
33	D25-077-2210	Pipe, 3/8"	1
34	D25-078-2210	Cap, 3/8"	1
35	D25-025-1033	Base	1
36	G25-054-2010	Washer, Shakeproof, M10	4
37	G10-029-2010	Screw, Cap, hex-hd	4
38	D25-125-2317	Washer, Dampening, polypropylene	6
	D25-125-2318	Washer, Dampening, PVDF	6
39	G25-088-2010	Screw, Cap, soc-hd	3
40	G25-106-2318	Gasket, cover	1
41	H25-105-1018	Housing cover	1
42	G25-090-2010	Screw, Cap, hex-hd	6
43	D25-100-1033	Manifold support	1

(1) Cylinder Housing Assembly includes cylinder casting (25), bearing cup (62A), adjusting plate (61), O-ring (60), and set screws (24).



Illinois Location:

(847) 841-7867

860 Church Rd Elgin, IL 60123

Minnesota Location:

(651) 758-7867

330 Mill Bay South Suite 1511 Afton, MN 55001

PumpSupplyInc.com

P600 Hydraulic End Parts List

Ref. No.	Part Number	Description	Quantity/ Pump
50	D25-019-3111	Spring, Piston return	3
51	D25-042-1010	Retainer, Piston return spring	3
52	D25-046-2110	O-ring, Valve cylinder, Buna-N	9
53	K25-045-3110	Spring, Sleeve valve.....	3
54	K25-044-1010	Valve Plunger	3
55	K25-043-1010	Cylinder, Valve	3
56	D25-034-2110	O-ring, Buna-N.....	6
57	D25-041-1010	Washer, Ball retainer.....	3
58	D25-015-3010	Ball	12
59	D25-014-1209	Piston, with foot and retainer.....	3
60	D25-075-2110	O-ring, Buna-N	1
61	D25-012-1010	Bearing Adjusting Plate.....	1
62	H25-007-1210	(X) Cam Assembly(2).....	1

Ref. No.	Part Number	Description	Quantity/ Pump
63	D25-085-2210	Key, Shaft.....	1
64	H25-031-2112	Seal, Buna-N.....	2
65	H25-037-2110	O-ring, Pump housing, Buna-N.....	1
66	K25-014-1210	Piston Assembly(1)	1
-	D25-111-2400	Label, Caution	1

(1) Piston Assembly includes items 50 through 59.

(2) Cam Assembly includes cam, shaft, wobble plate, bearings, and cups. It is only available as an assembly.

Hydraulic End Service

CAUTION: Disassembly of the hydraulic end of the pump should be performed only by a qualified technician. For assistance, contact Wanner Engineering (612-332-5681) or the distributor in your area.

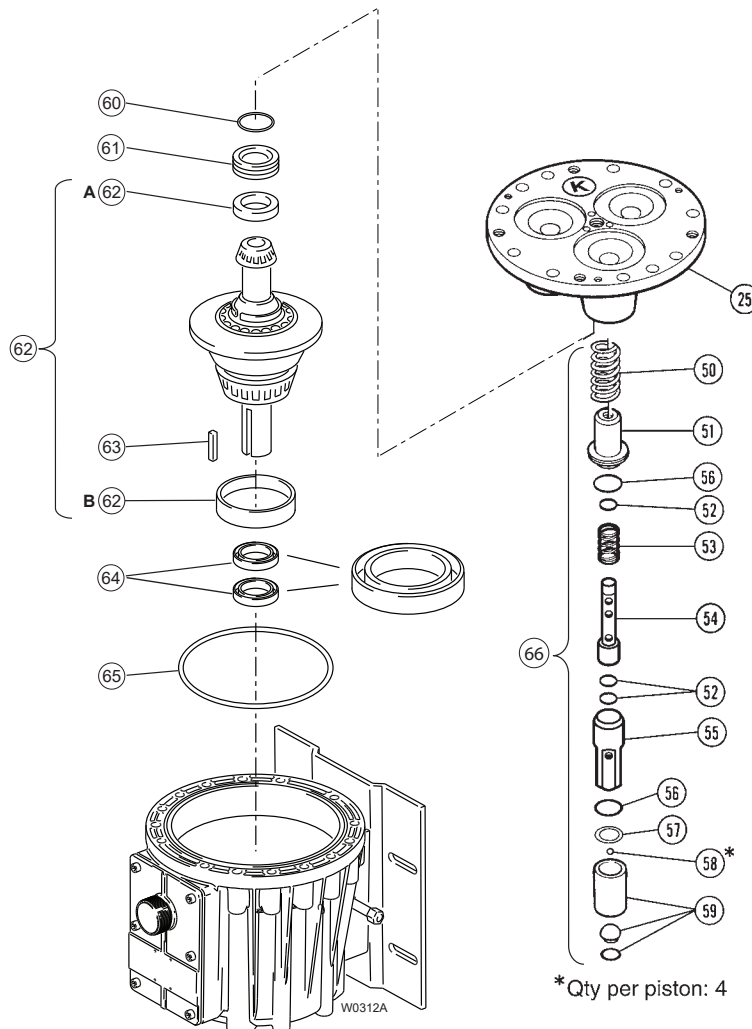

P600-63 Reducer Parts List (1 of 3)

Ref No.	Part Number	Description	Quantity/ Pump
1	P6-N-PUMP	P600 Pump Assembly.....	1
2	D25-085-2210	Key, Shaft.....	1
3	112-033	Key, 3/8 sq. x 1.125 lg.....	1
4	112-584	Shaft, P600-63	1
5	112-435	Reducer, 5:1 ratio	1
	112-434	Reducer, 7.5:1 ratio	1
	112-433	Reducer, 10:1 ratio	1
	112-432	Reducer, 15:1 ratio	1
	112-431	Reducer, 20:1 ratio	1
	112-430	Reducer, 25:1 ratio	1
	112-429	Reducer, 30:1 ratio	1
	112-428	Reducer, 40:1 ratio	1
	112-427	Reducer, 50:1 ratio	1
	112-426	Reducer, 60:1 ratio	1

Ref No.	Part Number	Description	Quantity/ Pump
6	112-555	Flange, Input, NEMA 56C	1
	112-556	Flange, Input, NEMA 143/145TC	1
	112-557	Flange, Input, NEMA 182/184TC	1
	112-558	Flange, Input, IEC 63 B5	1
	112-559	Flange, Input, IEC 71 B5	1
	112-560	Flange, Input, IEC 80 B5	1
	112-561	Flange, Input, IEC 90 B5	1
7	112-527	Screw, M10 x 1.5 x 40 mm, HHCS.....	4
8	112-526	Washer, Flat	4
9	112-034	Spacer, Pump, P600	1

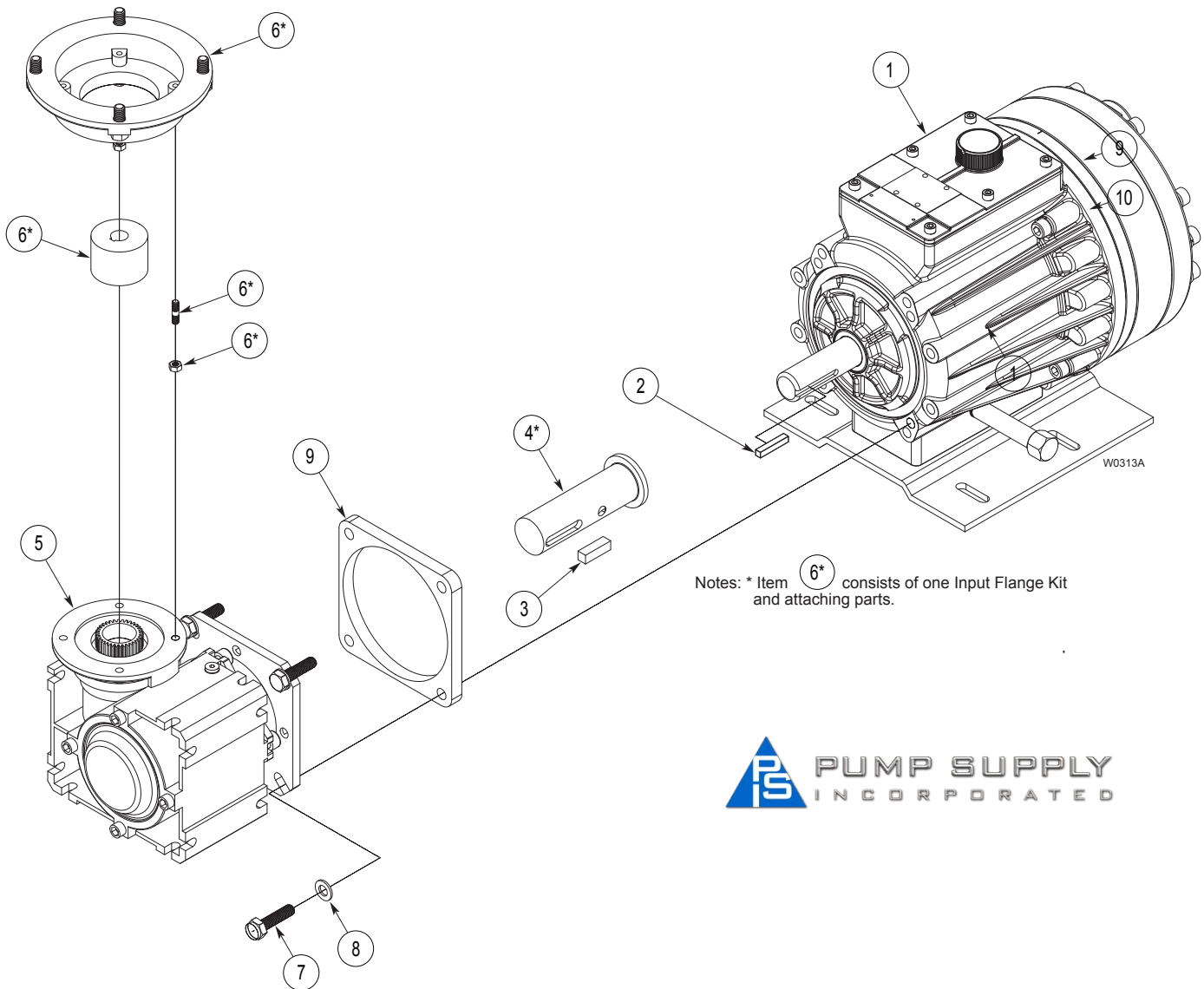

P600-75 Reducer Parts List (2 of 3)

Ref No.	Part Number	Description	Quantity/ Pump
1	P6-N-PUMP	P600 Pump Assembly.....	1
2	D25-085-2211	Key, 2 inch.....	1
3	112-528	Shaft.....	1
4	112-035	Shaft Kit.....	1
5	112-500	Reducer, 5:1 ratio	1
	112-501	Reducer, 7.5:1 ratio	1
	112-502	Reducer, 10:1 ratio	1
	112-503	Reducer, 15:1 ratio	1
	112-537	Reducer, 20:1 ratio	1
	112-538	Reducer, 25:1 ratio	1
	112-549	Reducer, 30:1 ratio	1
	112-539	Reducer, 40:1 ratio	1
	112-540	Reducer, 50:1 ratio	1
	112-541	Reducer, 60:1 ratio	1

Ref No.	Part Number	Description	Quantity/ Pump
6	112-520	Flange, Input, NEMA 56C.....	1
	112-521	Flange, Input, NEMA 143/145TC.....	1
	112-522	Flange, Input, NEMA 182/184TC.....	1
	112-562	Flange, Input, IEC 71 B5.....	1
	112-506	Flange, Input, IEC 80 B5.....	1
	112-551	Flange, Input, IEC 90 B5.....	1
	112-552	Flange, Input, IEC 100/112 B14.....	1
7	100-032	Locknut, M10, x 1.5, SST.....	4
8	D10-048-2012	Washer, Lock, SST, 182/184TC.....	4
9	D10-087-2012	Screw, 3/8-16 x 1.125, HHCS.....	4
10	112-031	Washer, Flat, wide, Type A, 3/8".....	8
11	G10-029-2022	Screw, M10 x 1.5 x 30 mm, HHCS.....	4
12	112-526	Washer, Flat, M10, SST.....	8
13	G25-029-2011	Screw, M10 x 1.5 x 25 mm, HHCS.....	4
14	112-519	Support, SST, 182/184TC.....	2
15	112-517	Base, 182/184TC.....	1

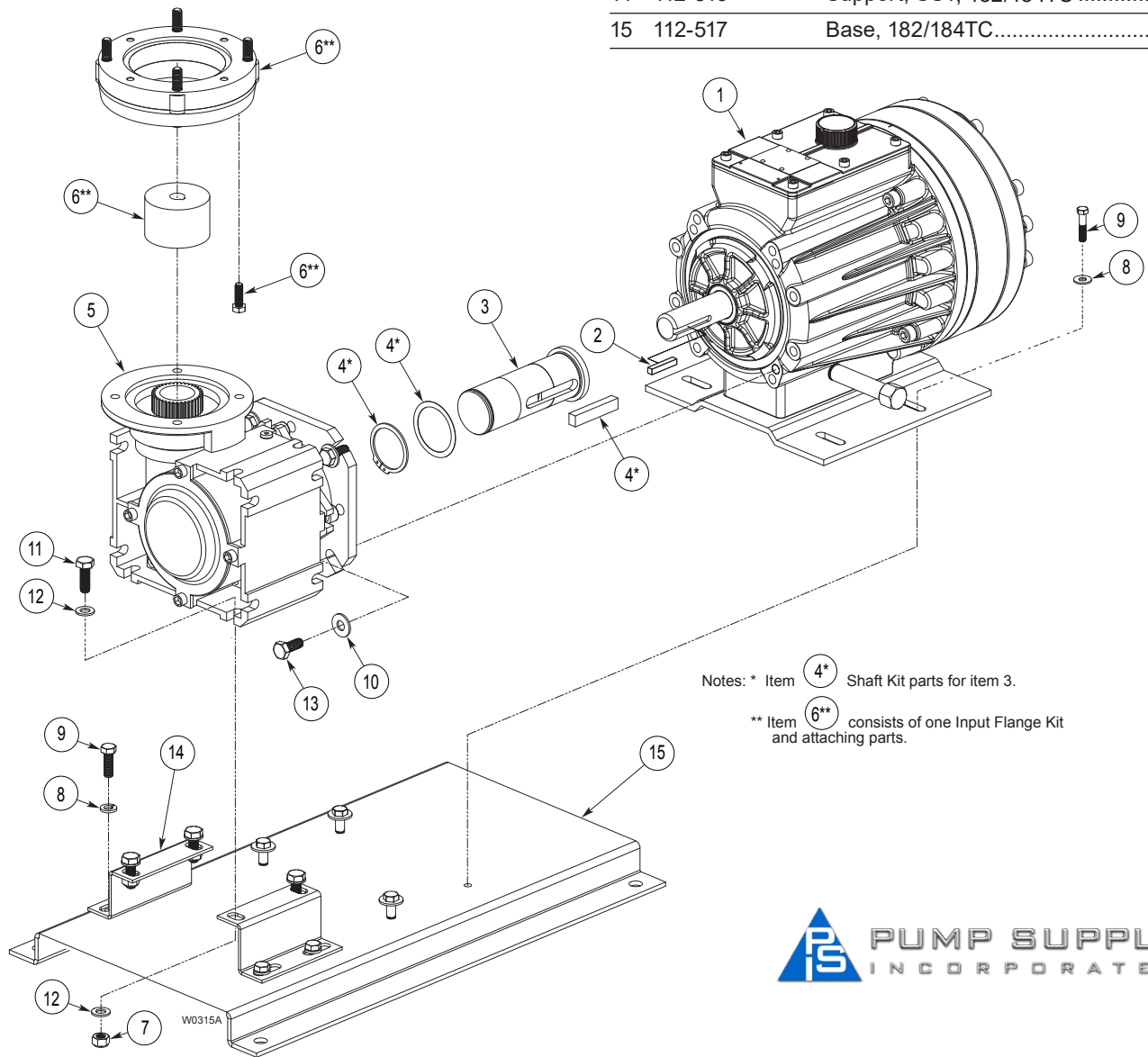

Notes: * Item 4* Shaft Kit parts for item 3.

** Item 6** consists of one Input Flange Kit and attaching parts.



P600 Reducer Parts List (3 of 3)

Ref No.	Part Number	Description	Quantity/ Pump
1	P6-N-PUMP	P600 Pump Assembly, Metallic	
2	112-700	Reducer, 5:1 ratio, 213/215TC	1
	112-701	Reducer, 7.5:1 ratio, 213/215TC	1
3	112-821	Guard	1
4	A04-116-2201	Hub, Coupling, 213/215TC	1
5	A04-115-2200	Sleeve, Coupling, 213/215TC	1
6	A04-116-2205	Hub, Coupling, 213/215TC	1

Ref No.	Part Number	Description	Quantity/ Pump
7	100-989	Screw, SST	4
8	C22-018-3102	Washer, Flat, SST	4
9	100-913	Screw, SST	8
10	D10-048-2012	Washer, Flat, SST	8
11	112-717	Base	1

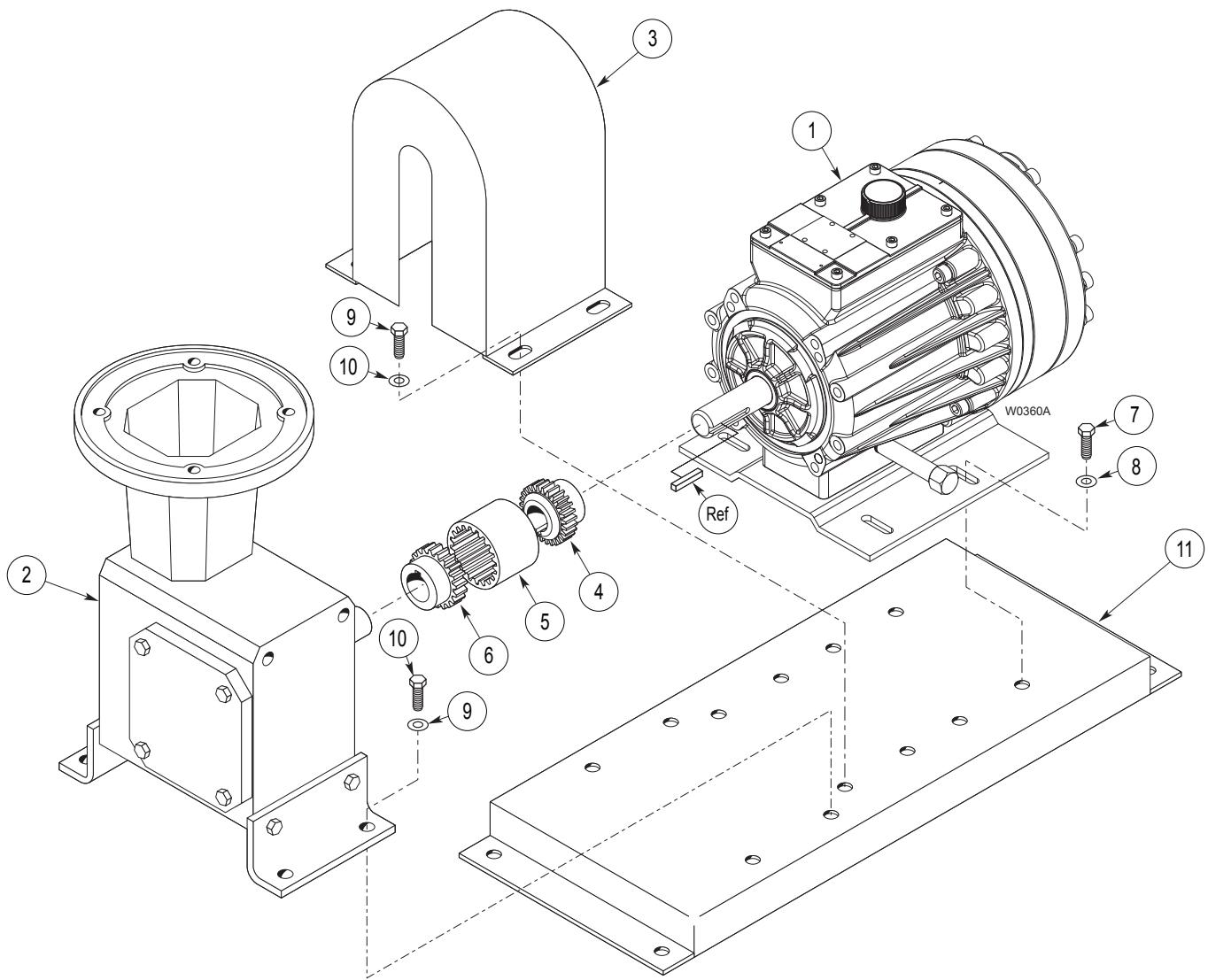

P600 Troubleshooting

Problem	Probable Cause	Solution
Motor/Pump Does Not Operate	No power.	Supply correct power according to motor requirements.
	Blown fuse/tripped circuit breaker.	Replace/reset, eliminate circuit overload.
	Shaft coupling to pump not in place.	Install proper coupling hardware (see parts list).
	Current overload - motor.	Motor not rated for pump operating conditions - install proper motor.
	Thermal overload - motor.	Motor not rated for pump and/or ambient operating conditions - supply cooling or install proper motor.
	Faulty motor drive/controller.	Repair/replace.
	Faulty motor.	Repair/replace.
No Delivery	Low liquid level in supply tank (if low-level shut-off is used).	Fill tank.
	Supply tank empty.	Fill tank.
	Loss of prime	Re-prime using Initial Start-Up Procedure.
	Inlet line or strainer clogged.	Clear debris and flush, or replace.
	Inadequate supply pressure at pump inlet.	Increase supply pressure by raising fluid level in tank, raising tank, or pressurizing suction tank.
	Inlet line too restrictive.	Increase inlet line diameter and/or decrease inlet line length.
	Fluid viscosity too high.	Reduce viscosity if possible (by heat or some other means). Increase inlet line diameter and/or decrease inlet line length. Increase supply pressure.
	Vapor lock/cavitation.	Increase inlet pressure. Decrease fluid temperature.
	Pump valves held open or worn out.	Clear debris and flush, or replace (see Fluid End Service)
Delivery Too Low and/or Erratic	System relief valve actuating.	Adjust relief valve, or repair, clean, or replace with new relief valve.
	Review all Probable Causes and Solutions in Problem 2 No Delivery above.	
	Air leak(s) in inlet line.	Locate all leaks and repair.
	System back pressure too low.	Adjust back pressure valve to higher setting. Install back pressure valve if none in system.
	Pumped fluid characteristics changed.	Monitor supply tank temperature to determine if fluid is too hot (leading to cavitation) or too cold (increasing fluid viscosity). Stabilize temperature at suitable level to resolve problem. Check for entrapped air in the fluid supply system.
	Inlet supply pressure changed.	Monitor inlet supply pressure (at the pump) to determine if it is too low, causing a starved condition/cavitation. Stabilize pressure at suitable level to resolve problem.
	Pump OK - Calibration system or flow meter error.	Evaluate components and repair/correct problem(s).
Delivery Too High and/or Erratic	Oil condition in pump hydraulic end changed.	Check oil level - if low evaluate for source of leakage. Consult factory for hydraulic end service. Change oil per recommended guidelines in maintenance section.
	System back pressure too low.	Adjust back pressure valve to higher setting. Install back pressure valve if none in system.
	Inlet supply pressure changed.	Monitor inlet supply pressure (at the pump) to determine if it is too high, causing a "flow-through" condition. Stabilize pressure at suitable level to resolve problem.
	Pump OK - Calibration system or flow meter error.	Evaluate components and repair/correct problem(s).

P600 Replacement Parts Kits

ORDERING INFORMATION: A Replacement Parts Kit contains 11 digits corresponding to customer-specified design options.

1	2	3	4	5	6	7	8	9	10	11
---	---	---	---	---	---	---	---	---	----	----

Digit	Order Code	Description
1-2	P6	Pump Configuration For all P600 Pumps
3	K D V	Kit Designator Complete Fluid End Kit* Diaphragm Kit* Valve Kit (diaphragm not included)
4-5	52 55	Pump Head Version Metallic Pump Head Non-Metallic Pump Head
6	B C M P S T X	Spring Retainers (Dampening Washers) For Brass pump head (Hastelloy C) For Cast iron pump head (Hastelloy C) For PVDF pump head (PVDF) For Polypropylene pump head (Polypropylene) For 316L Stainless Steel pump head (Hastelloy C) For Hastelloy C pump head (Hastelloy C) Not included in Diaphragm Kit
7	A E G S X J W P R Z T F Y	Diaphragm & O-ring Material Aflas (with PTFE O-rings) EPDM (EPDM-compatible oil) FKM (Standard oil) FKM (Food-contact oil) FKM (Synthetic oil) PTFE (Food-contact oil) PTFE (Synthetic oil) Neoprene (Standard oil) Neoprene (Food-contact oil) Neoprene (Synthetic oil) Buna-N (Standard oil) Buna-N (Food-contact oil) Buna-N (Synthetic oil)
8-9	SS TT SC SD TC TD XX	Check Valve Material (Spring/ Valve Seat / Valve) Elgiloy/ Nitronic / Nitronic 50 Hastelloy C / Hastelloy C/ Hastelloy C Elgiloy / Ceramic / Ceramic Elgiloy / Tungsten Carbide / Tungsten Carbide Hastelloy C / Ceramic / Ceramic Hastelloy C /Tungsten Carbide / Tungsten Carbide Not included in Diaphragm Kit

P600 Tool Kit

The P600 Tool Kit (Part No. A03-175-1102) contains the tools listed below. These tools are used to assist in the repair and maintenance of the P600. See the maintenance sections of this manual for specific application.

Ref. P600 No.	Tool Part No.	Tool Description	Quantity/Kit
1	A03-125-1000	Holder, Plunger.....	1
2	A03-156-1200	Assembly Studs.....	1
3	A03-162-1201	Lifter, Plunger guide	1
4	A03-124-1200	Lever Assembly	1
5	A03-119-1000	Seat Puller	1
6	A03-158-1001	Seal Protector	1
7	A03-160-1200	Insertor/Rotator	1
8	A03-126-1500	Tool Box	1

Illinois Location:
(847) 841-7867
860 Church Rd Elgin, IL 61

Minnesota Location:
(651) 758-7867
330 Mill Bay South Suite
Afton, MN 55001

PumpSupplyInc.com



* K&D Kits include hydraulic end oil. Oil not included in V Kit.

P600 Replacement Parts Kits (Cont'd)

Metallic Pump Head Kit Contents

Part Number*	Description	Qty	Kit Designator		
			K	D	V
D25-018-____	Diaphragm	3	•	•	
D25-047-____	O-ring, follower	3	•	•	
D25-074-____	O-ring, outlet valve	3	•	•	•
D25-097-____	O-ring, outer manifold	1	•	•	•
D25-073-____	O-ring, inner manifold	1	•	•	•
D25-083-____	O-ring, center bolt	1	•	•	•
D25-035-____	O-ring, valve seat	6	•		•
D25-020-____	Valve seat	6	•		•
D25-021-____	Valve	6	•		•
D25-022-____	Valve spring	6	•		•
D25-023-____	Retainer, valve spring	6	•		•
A01-113-3400	Threadlocker	1	•	•	
	Hydraulic end oil (2.5 qt)		•	•	

Non-Metallic Pump Head Kit Contents



Part Number*	Description	Qty	Kit Designator		
			K	D	V
D25-018-____	Diaphragm	3	•	•	
D25-047-____	O-ring, follower	3	•	•	
D25-109-____	O-ring, outer manifold	1	•	•	•
D25-073-____	O-ring, inner manifold	1	•	•	•
D10-083-____	O-ring, center manifold	1	•	•	•
D25-035-____	O-ring, valve seat	6	•		•
D25-020-____	Valve seat	6	•		•
D25-021-____	Valve	6	•		•
D25-022-____	Valve spring	6	•		•
D25-092-____	Tetra seal	6	•		•
D25-023-____	Retainer, valve spring	6	•		•
D25-125-____	Washer, dampening	6	•		•
A01-113-3400	Threadlocker	1	•	•	
	Hydraulic end oil (2.5 qt)		•	•	

* Last four digits of part numbers with ____ refer to specific material of construction.

Illinois Location:
(847) 841-7867
860 Church Rd Elgin, IL 61

Minnesota Location:
(651) 758-7867
330 Mill Bay South Suite
Afton, MN 55001

PumpSupplyInc.com

P600 Warranty

Limited Warranty

Wanner Engineering, Inc. extends to the original purchaser of equipment manufactured by it and bearing its name, a limited one-year warranty from the date of purchase against defects in material or workmanship, provided that the equipment is installed and operated in accordance with the recommendations and instructions of Wanner Engineering, Inc. Wanner Engineering, Inc. will repair or replace, at its option, defective parts without charge if such parts are returned with transportation charges prepaid to Wanner Engineering, Inc., 1204 Chestnut Avenue, Minneapolis, Minnesota 55403.

This warranty does not cover:

1. The electric motors (if any), which are covered by the separate warranties of the manufacturers of these components.
2. Normal wear and/or damage caused by or related to abrasion, corrosion, abuse, negligence, accident, faulty installation or tampering in a manner which impairs normal operation.
3. Transportation costs.

This limited warranty is exclusive, and is in lieu of any other warranties (express or implied) including warranty of merchantability or warranty of fitness for a particular purpose and of any non-contractual liabilities including product liabilities based on negligence or strict liability. Every form of liability for direct, special, incidental or consequential damages or loss is expressly excluded and denied.



Illinois Location:

(847) 841-7867

860 Church Rd Elgin, IL 60120

Minnesota Location:

(651) 758-7867

330 Mill Bay South Suite 100
Afton, MN 55001

PumpSupplyInc.com

