



CRANE PUMPS & SYSTEMS

TRIED & TRUE CHOPPING PERFORMANCE

TRUST SITHE TO REPLACE YOUR NEXT FAILED PUMP



CHOP & MACERATE SOLIDS

IN EXTREMELY CHALLENGING WASTE WATER APPLICATIONS

SITHE Chopper pumps are Barnes solution to highly demanding waste water applications in the collection systems market. The largest problem customers face in the waste water industry is clogging of non clog pumps and downstream piping. SITHE chopper pumps solve clogging with a unique, first-of-its-kind, patent pending chopping technology that slices even the most troublesome solids in waste stream.



 **OPEN CENTER CUTTING DESIGN**

 **EASE OF SERVICING**

 **HIGH RELIABILITY**

 **INDUSTRY BEST LEAD TIME**



Numerous options, kits & accessories



Field replaceable blades



Plug-n-play quick connect cord

FEATURES

- 1 Large Stainless Steel Lifting Bail**
Facilitates easy hooking for pump removal
- 2 VFD Ready Motor**
With 1.2 service factor, class H magnet wire
- 3 Tapered Keyed Shaft**
Reduces vibration & increases seal life
- 4 Stainless Hardware**
Increases corrosion resistance
- 5 Heat Treated Blades Open Center Design**
For superior slicing and sustained sharpness
- 6 Plug-n-Play Quick Connect Cord**
Simplifies pump installation & removal
- 7 Liquid Cooled Motor**
Enhances motor cooling & increases bearing life
- 8 High Capacity Bearings**
Provides 50,000 hour bearing life at 2 ft/sec flow
- 9 Axalta Epoxy Coating**
Improves durability & aesthetics
- 10 Slotted Discharge**
Adapts to ANSI and ISO flanges

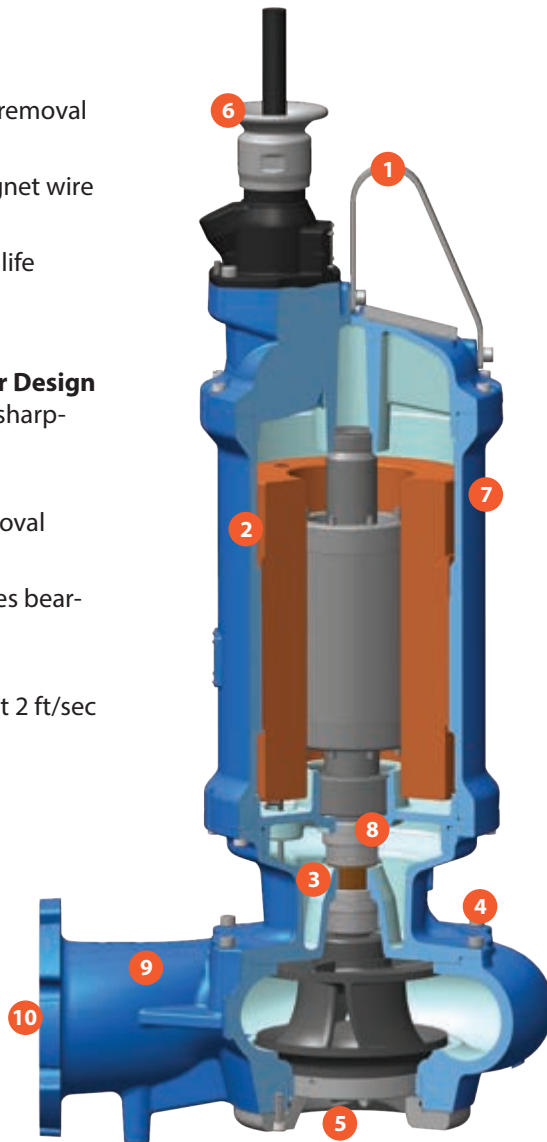

Unique, patented open center cutter mechanism



Solids size reduction to 1" to 3" prevent clogging of down-stream component



COMPREHENSIVE HYDRAULIC COVERAGE

