



## **MODELS: NC 06360/08360/10360-M**

### **OPERATING INSTRUCTIONS, INSTALLATION & MAINTENANCE MANUAL INCLUDING SPARE PARTS LIST**



**Illinois Location:**

(847) 841-7867  
860 Church Rd Elgin, IL 60120

**Minnesota Location:**

(651) 758-7867  
330 Mill Bay South Suite  
Afton, MN 55001

PumpSupplyInc.com



**ISO 9001 Certified**



## LIFE IS PRECIOUS - THINK SAFETY

1. Most accidents can be avoided by using COMMON SENSE.
2. Please read the operation and maintenance instruction manual supplied with the pump. If you did not receive one, please call your local distributor before pump installation.
3. Do not wear loose apparel that may become entangled in the impeller or other moving parts.
4. Always use appropriate safety equipment, such as safety glasses, when working on the pump or piping.
5. Pumps build up heat and pressure during operation-allow time for pumps to cool before handling or servicing.
6. Only qualified service personnel should install, operate and repair pump.
7. Keep clear of suction and discharge openings. DO NOT insert fingers in pump with power connected.
8. Do not pump flammable or hazardous materials (gasoline, acids, alkalis, etc.)
9. Do not block or restrict discharge hose, as it may whip or burst catastrophically under pressure.
10. Make sure lifting handles/hooks are securely fastened each time before lifting.
11. Do not lift pump by the power cord under any circumstances.
12. Do not exceed manufacturer's recommendation for optimum performance, as this could cause the motor/pump to overheat and lead to premature wear or failure.
13. Secure the pump in its operating position so it does not tip over, fall or slide.
14. Keep away from impeller when power is connected.
15. Submersible Pumps are not approved for use in swimming pools, recreational water installations, decorative fountains or any installation where human contact with the pumped fluid is common.
16. Do not operate pump without adequate protection and safety devices in place.
17. Always replace safety devices that have been removed during service or repair.
18. To reduce risk of electrical shock, pump must be properly grounded in accordance with the National Electric Code and all applicable state and local codes and ordinances.
19. To reduce risk of electrical shock, always disconnect the pump from the power source before handling or servicing.
20. Any wiring of pumps should be performed by a qualified electrician.
21. Never operate a pump with a power cord that has frayed or brittle insulation.
22. Cable should be protected at all times to avoid punctures, cuts, and abrasions - inspect frequently.
23. Never handle connected - "hot" power cords with wet hands.
24. Never operate a pump with a plug-in type power cord without a ground fault circuit interrupter, adequate overload and short circuit protection.

**IMPORTANT !!!** MODY Pumps Inc. is not responsible for losses, injury, or death resulting from a failure to observe these safety precautions, misuse or abuse of pumps or equipment.

## GENERAL INFORMATION.

THE "mody" NC-M SERIES LINE OF SUBMERSIBLE PUMPS ARE PRIMARILY DESIGNED FOR HANDLING SLUDGE AND SOLIDS. THEY CAN ALSO BE USED FOR HANDLING WASTE WATER, FLY ASH, CERAMIC SLIP AND IN OTHER ALLIED APPLICATIONS WHERE THE CONCENTRATION OF SUSPENDED SOLIDS IS HIGH.

THE SERVICE LIFE OF A SUBMERSIBLE PUMP DEPENDS MAINLY ON TWO THINGS: THE DEPENDABILITY OF THE SEALING SYSTEM AND THE WEAR RESISTANCE OF THE PUMP ITSELF.

IN THE NC-M SERIES PUMPS, THE WEAR PLATE IS RUBBERLINED WHILE THE VOLUTE AND IMPELLER ARE MADE OF CAST STAINLESS STEEL. THE IMPELLER IS A RECESSED VORTEX DESIGN THAT ALLOWS THE PUMP TO HANDLE 2 1/2" SPHERICAL SOLIDS. ALL LARGE PARTICLES ARE SUCKED IN USING THE VORTEX CREATED BY THE IMPELLER AND PASS OUT DIRECTLY THROUGH THE DISCHARGE.

ALL MODELS HAVE BUILT-IN THERMAL PROTECTION, WHICH CAN BE AUGMENTED WITH AN OVERCURRENT RELAY. **IT IS HOWEVER RECOMMENDED THAT IRRESPECTIVE OF TYPE OF PUMP, ADEQUATE MOTOR PROTECTION SWITCHGEAR SHOULD BE USED AT THE INSTALLATION. WE STRONGLY RECOMMEND THE USE OF SUITABLE CONTROL PANELS WHICH ARE AVAILABLE FROM US INCORPORATING ALL REQUIRED PROTECTION.**

IT IS IN THE INTEREST OF THE USER THAT HE GO THROUGH THIS MANUAL IN DETAIL PRIOR TO USING THE PUMP. THIS MANUAL WILL HELP HIM UNDERSTAND THE CONSTRUCTIONAL FEATURES AND TO OBTAIN TROUBLE FREE SERVICE FROM THE PUMP.

## TECHNICAL DESCRIPTION.

THE PUMPSET IS IN A MODULAR CONSTRUCTION ENSURING EASY AND SIMPLE SERVICEABILITY. THE MAJOR DESIGN FEATURES ARE AS UNDER:

**A] THERMAL PROTECTION:** SEE UNDER "MOTOR PROTECTION"

**B] THE MOTOR:** A RUGGED ALUMINUM DIE CAST ROTOR, DYNAMICALLY BALANCED TO GRADE 2.5 ACCURACY OF ISO 942. A STAINLESS STEEL SHAFT RUNNING IN TWO DEEP GROOVE BALL BEARINGS. INSULATION CLASS "H" (180 DEGREES CELSIUS). END WINDINGS DULY EPOXY COATED TO PREVENT DETERIORATION OF INSULATION EVEN IN EXTREMELY HUMID CONDITIONS. WINDING WIRE IS DUAL COATED SUITABLE FOR "H" CLASS INSULATION.

**C] THE SEAL CHAMBER:** THE HEART OF THE "MODY" PUMP. DUAL MECHANICAL SEALS, TUNGSTEN CARBIDE V/S TUNGSTEN CARBIDE SEAL FACES (LOWER SEAL) AND TUNGSTEN CARBIDE V/S TUNGSTEN CARBIDE (UPPER SEAL). SIMILAR SEALS OF HYR RUBBER AND METAL PARTS IN STAINLESS STEEL, RUNNING IN AN OIL BATH, ENCLOSED IN A PRESSURE COMPENSATING RUBBER GASKET, CREATES THE ULTIMATE SEAL SOLUTION. THE DESIGN OPTIMIZES SEAL LIFE AND ALLOWS FOR SIX MONTHLY (2500 HRS) SERVICE INTERVALS.

**D] BEARINGS:** SINGLE ROW DEEP GROOVE BALL BEARING (UPPER), DOUBLE ROW ANGULAR CONTACT BEARING (LOWER) SEALED FOR LIFE WITH A SPECIAL HIGH TEMPERATURE BEARING GREASE REQUIRING NO PERIODIC MAINTENANCE WHATSOEVER.

**E] THE HYDRAULIC ELEMENTS :** A RECESSED VORTEX STAINLESS STEEL IMPELLER (AVAILABLE IN CORROSION RESISTANT 304 SS OR IN ABRASION RESISTANT 410 HARDENED SS RUNNING AGAINST A RUBBERLINED WEAR PLATE. THE VOLUTE IS STAINLESS STEEL OF AISI 304 QUALITY, DESIGNED FOR LARGE SOLID HANDLING CAPACITY OF 2 1/2"

**F] CABLE GLAND ASSEMBLY:** THE PUMP IS SUPPLIED WITH 50 FEET CABLE AS STANDARD. THE CABLE IS A 4 CORE EPR SHEATHED AND INSULATED CONFORMING TO INT'L STD. THE CABLE IS WATERPROOF AND CAN BE COMPLETELY SUBMERGED IN WATER. THE CABLE IS TERMINATED IN THE PUMP AT THE CABLE GLAND. THE GLAND ASSEMBLY SEALS THE CABLE ON THE OUTSIDE SHEATH. A WATER DAM ARRANGEMENT IS ALSO PROVIDED WHICH SEALS THE INDIVIDUAL CORES OF THE CABLE. THIS FEATURE IS UNIQUE AND IS ESSENTIAL TO PREVENT WATER SEEPING THROUGH THE CORES OF THE CABLE INTO THE TERMINAL CHAMBER IN THE EVENT OF A CUT CABLE. THE CABLE IS ALSO SHEATHED FOR THE FIRST ONE METER BY MEANS OF A CABLE GRIP MADE OF STAINLESS STEEL. THIS IS ESSENTIAL TO ENSURE THAT THERE IS NO UNDUE STRAIN ON THE CABLE IF THE PUMP IS PULLED OR LOWERED INADVERTENTLY BY MEANS OF THE CABLE. COMPLETE DETAILS OF THE CABLE GLAND ASSEMBLY ARE SHOWN IN THE DRAWING.

**G] ELECTRICAL INFORMATION:** MOTORS ARE TYPICALLY DESIGNED TO OPERATE ON 230/460V AT 60 HZ, 415V AT 50 HZ. EXPORT DESTINED PUMPS ARE PREWIRED FOR SINGLE VOLTAGE AND FREQUENCY. MAXIMUM DEVIATION IN VOLTAGE ALLOWED IS -/+ 6% AND FREQUENCY -/+ 3%. CHECK NAME PLATE FOR OPERATING VOLTAGE AND FREQUENCY.

**INSTALLATION.**

- CHECK THAT THE SITE VOLTAGE CORRESPONDS WITH THAT OF THE PUMP.
- CHECK THAT FUSES ARE INTACT.
- USE SHORTEST POSSIBLE HOSE IN RECOMMENDED DIMENSION. AVOID SHARP BENDS, CREASES, AND CONTRACTIONS.
- **THE MAXIMUM SUBMERGENCE RECOMMENDED IS 50 FEET.**
- **THE SPECIFIC GRAVITY OF THE PUMPED FLUID SHOULD NOT EXCEED 1.1.**
- NEVER LIFT OR PULL THE PUMP BY MEANS OF THE CABLE. SUSPEND THE PUMP BY A ROPE OR PREFERABLY PLACE IT ON A SOLID BASE.
- WIRE THE PUMP TO THE MAINS CORRECTLY. ALWAYS USE A STARTER OR A PANEL BOARD. SEE INSTRUCTIONS UNDER "MOTOR PROTECTION" BELOW.
- AT THE STARTING MOMENT, THE PUMP SHALL MAKE A KICK, WHICH IS OPPOSITE TO THE DIRECTION OF ROTATION OF THE IMPELLER. SHIFT TWO PHASES IN THE POWER CONNECTION IF THE KICK IS IN THE WRONG DIRECTION. THE CORRECT DIRECTION IS INDICATED ON THE PUMP COVER AT THE TOP OF THE PUMP.
- CHECK LEVEL AND CONDITION OF THE OIL AT SERVICE EVERY SIX MONTHS. IF THE OIL IS EMULSIFIED BY WATER THE SEALS MUST BE REPLACED.
- THE SHAFT SEAL SHOULD BE CHECKED FOR WEAR EVERY 2500 HRS. OF OPERATION. IF SEAL FACES SHOW ANY SIGNS OF WEAR, THEY SHOULD BE REPLACED. REFER TO PAGE 5 FOR SERVICING THE PUMP SEALS.

**HRC FUSE RECOMMENDED**

<b>MAINS VOLTAGE AT SITE</b>	<b>NC06 M</b>	<b>NC08 M</b>	<b>NC10 M</b>
220 VOLTS 3 PHASE	25 AMPS	30 AMPS	40 AMPS
380 VOLTS 3 PHASE	16 AMPS	20 AMPS	25 AMPS
415 VOLTS 3 PHASE	16 AMPS	16 AMPS	25 AMPS
460 VOLTS 3 PHASE	16 AMPS	16 AMPS	25 AMPS



TROUBLE GUIDE	CAUSE	REMEDY
---------------	-------	--------

**PUMP DOES NOT START**

- |                         |                          |  |
|-------------------------|--------------------------|--|
| 1.FUSES BLOWN.          | 1.REPLACE FUSES          |  |
| 2.CABLE DAMAGED         | 2.SHORTEN/REPLACE CABLE  |  |
| 3.NO POWER              | 3.CHECK POWER SUPPLY     |  |
| 4.BLOCKED IMPELLER      | 4.CLEAN WET END          |  |
| 5.STATOR WINDING BURNT. | 5.REPLACE STATOR.        |  |
| 6.CONTACTOR COIL BURNT  | 6.REPLACE COIL           |  |
| 7.SEAL PROBE SENSOR     | 7.CHANGE OIL/MECH. SEALS |  |

**PUMP STARTS BUT BUT STOPS**

- |                                       |                         |  |
|---------------------------------------|-------------------------|--|
| 1.BLOCKED IMPELLER.                   | 1.CLEAN BOTTOM PARTS.   |  |
| 2.IMPELLER ROT.WRONG                  | 2.SHIFT TWO PHASE CONN. |  |
| 3.CONNECTED FOR WRONG VOLTAGE.        | 3.CHECK & RECONNECT.    |  |
| 4.VOLTAGE TOO LOW/HIGH.               | 4.APPROACH POWER CO.    |  |
| 5.PUMP RUNNING DRY                    | 5.SWITCH OFF POWER      |  |
| 6.WATER TOO WARM (ABOVE 60 DEGREES C) | 6.SWITCH OFF POWER      |  |

**PUMP OUTPUT LOW**

- |                                     |                         |  |
|-------------------------------------|-------------------------|--|
| 1.IMPELLER ROT.BACKWARD.            | 1.SHIFT TWO PHASE CONN. |  |
| 2.PUMP WORN DOWN.                   | 2.REPLACE IMPELLER.     |  |
| 3.LONG HOSE AND DIAMETER TOO SMALL. | 3.CHECK PRESSURE LOSSES |  |
| 4.PRESSURE HEAD TOO HIGH            | 4.INSTALL BIGGER PUMP.  |  |
| 5.LEAKING/CRACKED OUTLET            | 5.REPLACE OUTLET/GASKET |  |

**MOTOR PROTECTION**

IT IS ESSENTIAL THAT THE PUMP BE USED WITH A STARTER AND PREFERABLY A PANEL BOARD. PANEL BOARDS INCORPORATING ALL PROTECTIVE DEVICES ARE AVAILABLE WITH US. THE FULL LOAD AMPERE RATINGS OF THE THREE MODELS ARE AS PER TABLE BELOW. THE OVERLOAD RELAY IN THE STARTER SHOULD CHOSEN ACCORDINGLY AND AMPERES SET AT THE FULL LOAD SETTING FOR THE PARTICULAR MODEL OF THE PUMP.(DETAILS BELOW ARE FOR 460 VOLT PUMPS. CHECK FULL LOAD AMPERES FOR DIFFERENT VOLTAGES ON PUMP NAME PLATE)

MODEL	FULL LOAD AMPERES.		
	230v	415v	460v
NC 06360M	20 AMPS	10.8 AMPS	9.8 AMPS
NC 08360M	24 AMPS	13.3 AMPS	12 AMPS
NC 10360M	31 AMPS	15.5 AMPS	14 AMPS

**Illinois Location:**  
(847) 841-7867  
860 Church Rd Elgin, IL 61

**Minnesota Location:**  
(651) 758-7867  
330 Mill Bay South Suite  
Afton, MN 55001  
[PumpSupplyInc.com](http://PumpSupplyInc.com)





**PUMP SUPPLY**  
INCORPORATED



## **SEAL PROBE (WATER-IN-OIL SENSOR)**

PUMP CAN ALSO BE EQUIPPED WITH A WATER-IN-OIL SENSOR FITTED IN THE CONTACTOR CHAMBER. A CONDUCTIVITY PROBE IS FITTED IN THE SEAL CHAMBER & MONITORS THE CONDITION OF THE OIL. IN THE EVENT OF A CONTAMINATION OF THE LUBRICATING OIL BY PUMPED WATER THE PROBE SENDS A SIGNAL TO THE BUILT IN SENSOR WHICH CUTS OFF POWER TO THE MOTOR. THIS INDICATES A SEAL FAILURE OR WORN OUT SEAL AND IT IS NECESSARY TO REPLACE THE SEALS AND FILL IN NEW OIL.

THE CONDUCTIVITY PROBE IS CONNECTED TO A 24V AC SUPPLY THROUGH A TRANSFORMER. IN THE EVENT OF A SEAL FAILURE AND CONTAMINATION OF OIL BY WATER (APPROX. 10%) THE PROBE GENERATES A SIGNAL, DETECTED BY A SENSOR, WHICH OPERATES A RELAY THROUGH THE BRIDGE RECTIFIER. THIS RELAY OPERATES THE CO CONTACT WHICH OPENS THE COIL CIRCUIT OF THE MAIN CONTACTOR AND ISOLATES THE PUMP FROM THE POWER SUPPLY.

THE SENSOR COMPLETE WITH TRANSFORMER IS HOUSED IN A SHEET STEEL ENCLOSURE DULY WIRED. THE ENCL. INCORPORATES AN LED AND A REMOVABLE FUSE. IN THE EVENT OF WATER CONTAMINATION IN THE OIL THE SENSOR WILL ISOLATE THE PUMP AND THE LED WILL LIGHT UP INDICATING THE OPERATION OF THE SENSOR. THE PUMP WILL NOT START IN THIS CONDITION. IF YOU WOULD LIKE TO OPERATE THE PUMP, REMOVE THE FUSE AND START THE PUMP.

WARNING: THE UNIT SHOULD NOT BE OPERATED FOR MORE THAN 10 DAYS AFTER THE SENSOR HAS TRIPPED THE PUMP. THE PROBE OPERATION IS AN EARLY WARNING SIGNAL THAT THE SEALS NEED REPLACEMENT --- DO NOT IGNORE THE SAME. IT IS ESSENTIAL THAT THE SEALS BE REPLACED AND NEW OIL FILLED AS SOON AS POSSIBLE TO PREVENT FURTHER DAMAGE TO THE UNIT. THE FUSE SHOULD BE REMOVED AND THE PUMP OPERATED IF ABSOLUTELY NECESSARY.

IN THE EVENT OF OVERHEATING OF THE STATOR WINDING FOR ANY REASON, THE EMBEDDED THERMAL SWITCHES WILL OPEN, CAUSING THE STARTER COIL TO DROP OUT AND ISOLATE THE PUMP UNIT FROM THE MAINS. THESE SWITCHES DO NOT PROVIDE ANY PROTECTION IN THE CASE OF A SHORT CIRCUIT, AND ADEQUATE H.R.C. FUSES SHOULD BE USED FOR SHORT CIRCUIT PROTECTION.

## **GENERAL OVERHAUL AND OIL CHECK. (ALL MODELS)**

### **DIS-ASSEMBLY (REFER DRG.NO.NC/200/01 SHEET 1 & 2)AT END OF MANUAL**

1. ALWAYS REPLACE O-RINGS WITH NEW ONES WHENEVER DISMANTLING AND RE-ASSEMBLING A PUMP. NEVER RE-USE OLD O-RINGS.
2. ALWAYS ISOLATE THE UNIT BEFORE REMOVING THE CONTACTOR COVER (1).BE CAREFUL WITH O-RINGS (8) AND SEALING SURFACES. PROTECT THE CONTACTOR CHAMBER AGAINST RAIN AND MOISTURE. CLEAN THE SEALING SURFACES CAREFULLY AND GREASE THE NEW O-RINGS BEFORE FITTING THE SAME. DO NOT USE THE OLD O-RINGS.
3. DISCONNECT STATOR LEADS AND CHECK COIL OF CONTACTOR AND CONDITION OF CONTACTS. IF CONTACTS ARE CORRODED OR PITTED, REPLACE CONTACTOR OR A NEW SET OF CONTACTS. SNIP OFF LEAD WIRE CONNECTORS AND UNSCREW GROMMET NUT (48). REMOVE LEAD WASHER (49) AND LEAD GROMMET (47). SLACKEN MOTOR LEAD WIRES TO FACILITATE REMOVAL OF STATOR LATER, IF NECESSARY.
4. LOOSEN NUT (5) AND REMOVE OUTLET (24/27).
5. LOOSEN NUTS (5)(4 NOS TIGHTENING VOLUTE AGAINST PUMP BASE) AND REMOVE VOLUTE. THE VOLUTE HAS TO BE MANEUVERED AND SLIDES OUT FROM ONE OPENING IN THE PUMP BASE (23).
6. THE IMPELLER (33/34/35/93/94/95) IS NOW IN VIEW.

7. LOOSEN NUT (30), REMOVE LOCK WASHER (31). SLIDE IMPELLER OFF THE SHAFT. REMOVE KEY (32) AND SLIDE OFF TRIMMING SPACER.

8. LOOSEN NUTS (41) (4 NOS WHICH TIGHTEN THE PUMP BASE AGAINST THE LOWER BEARING BRACKET (21) AND TAP OFF THE PUMP BASE. THE WEAR PLATE (36) WILL COME OFF WITH THE PUMP BASE.

9. UNSCREW THE FOUR CHEESE HEAD SCREWS (74) AND REMOVE THE SAND GUARD (71) FROM THE SEAL HOUSING (39).

10. THE OIL DIAPHRAGM (68) IS NOW IN VIEW. PRY OUT OIL PLUG CAPS (22) AND UNSCREW BOTH THE OIL PLUGS (78). DRAIN OUT THE OIL FROM THE OIL CHAMBER. LOOSEN SCREWS AND NUTS (51 & 66) FROM THE BIG OIL CLAMP (67) AND REMOVE CLAMP. TURN OIL DIAPHRAGM INSIDE OUT AND REMOVE SMALL OIL CLAMP IN THE SAME FASHION. REMOVE OIL DIAPHRAGM. SLIDE OFF CIRCLIP CAP (72) AND REMOVE CIRCLIP (73) FROM ROTOR SHAFT. REMOVE LOWER MECHANICAL SEAL (75) FROM ROTOR SHAFT. BE VERY CAREFUL IN HANDLING THE TUNGSTEN CARBIDE SEAL FACE. LEAVE THE STATIONARY TUNGSTEN CARBIDE SEAT IN THE SEAL HOUSING (39). UNSCREW FOUR NUTS (77) AND PULL OUT SEAL HOUSING. THE TC SEAL FACE WILL COME OUT WITH THE HOUSING. HANDLE THE FACE CAREFULLY. DO NOT REMOVE FROM HOUSING IF IT SEEMS OK AND DOES NOT NEED REPLACEMENT. THE UPPER MECHANICAL SEAL IS NOW IN VIEW. REMOVE THE UPPER SEAL IN THE SAME WAY AS THE LOWER SEAL. LEAVE THE TC SEAT IN THE LOWER BEARING BRACKET (21).

11. REMOVE THE FOUR NOS DEEP SEATED CAP SCREWS (40) THAT HOLD THE LOWER BEARING BRACKET AGAINST THE STATOR CASING. BY MEANS OF TWO SCREW DRIVERS REMOVE THE LOWER BRACKET FROM THE STATOR CASING. THE COMPLETE ROTOR (14,15,16) WITH BEARINGS (80), BEARING COVER (20) AND TC SEAT WILL COME OUT WITH THE LOWER BRACKET. REMOVE BOLTS (82) AND REMOVE BEARING COVER. PULL OUT ROTOR WITH BEARINGS FROM LOWER BRACKET. (IF THIS IS DIFFICULT, USE A HAND PRESS TO REMOVE ROTOR FROM BEARING BRACKET. ENSURE NO DAMAGE OCCURS TO THE TC SEAT IN BRACKET). THE TC SEAT CAN NOW BE PUSHED OUT FROM THE BEARING SIDE BY GENTLY TAPPING THE SAME. USE FINGERS OR A NYLON TIPPED HAMMER ONLY.

12. CHECK BOTH UPPER AND LOWER BEARINGS FOR ANY RADIAL OR AXIAL PLAY OR ANY ABNORMAL NOISE WHILE SPINNING THE SAME. CHECK FOR ANY LEAKAGE OF GREASE THROUGH THE SHIELD OF THE BEARING. IF THE BEARING SEEMS WORN OUT OR ANY GREASE LEAKAGE IS OBSERVED, REPLACE BEARING. USE BEARINGS WHICH ARE FILLED WITH A HIGH TEMPERATURE GREASE WITH A DROP POINT OF AT LEAST 240 DEGREES CELSIUS.

13. THE UPPER BEARING BRACKET (9) IS HELD IN PLACE BY TWO STUD BOLTS (4) ON THE STATOR CASING (17/18/19). UNSCREW NUTS (5) AND REMOVE BEARING BRACKET FROM STATOR CASING. USE SCREWDRIVERS TO PRY OUT THE SAME.

14. THE STATOR IS SHRINK FITTED IN THE CASING AND IS SUPPLIED WITH O-RINGS (10) AS ONE UNIT.

### **RE-ASSEMBLY OF THE PUMPSET:**

THE RE-ASSEMBLY OF THE UNIT CAN BE DONE BY REVERSING THE DIS-ASSEMBLY PROCEDURE. IT IS MANDATORY THAT ALL "O" RINGS BE REPLACED WHENEVER A PUMP IS OVERHAULED OR DISMANTLED. UNDER NO CIRCUMSTANCES SHOULD OLD "O" RINGS BE USED, EVEN IF THEY SEEM O.K.

#### **Illinois Location:**

(847) 841-7867  
860 Church Rd Elgin, IL 60120

#### **Minnesota Location:**

(651) 758-7867  
330 Mill Bay South Suite  
Afton, MN 55001

PumpSupplyInc.com





**OIL SPECIFICATIONS**

- A) H.P. ENKLO OIL 46/48  
 B) SHELL TELLUS 29.  
 C) CHEVRON UNIVOLT 60/N61

**USE NON-CONDUCTIVE, NON-FOAMING OIL ONLY**

**PLEASE NOTE THE SEAL CHAMBER CONTAINS APPROX. 1.6 LITRES OF OIL.**

**RECOMMENDED SPARES FOR TWO YEARS OPERATION (NC SERIES)**

S. NO.	DESCRIPTION	PART NO.	QUANTITY
1.	MECHANICAL SEAL	535-022-00	1 NO.
2.	MECHANICAL SEAL	535-022-00	1 NO.
3.	"O" RING SET	375-004-66	2 SETS.
4.	CABLE GROMMET	260-017-66	2 NOS.
5.	LEAD GROMMET	260-031-66	2 NOS.
6.	UPPER BEARING	020-005-07	1 NO.
7.	LOWER BEARING	020-014-07	1 NO.
8.	IMPELLER (NC10360M)	300-051-22	1 NO.
9.	WEAR PLATE	715-005-80	1 NO.
10.	CONTACTOR (NC10360M)	100-009-00	1 NO.
11.	LOCK WASHER	695-004-21	1 NO.

**\* PLEASE SPECIFY IMPELLER # PER PUMP MODEL and Frequency**

**Illinois Location:**  
 (847) 841-7867  
 860 Church Rd Elgin, IL 60120

**Minnesota Location:**  
 (651) 758-7867  
 330 Mill Bay South Suite  
 Afton, MN 55001

PumpSupplyInc.com



**PUMP SUPPLY**  
INCORPORATED

MODY DUAL VOLTAGE, 3Ph-230/460v 9 LEAD WINDING DIAGRAM

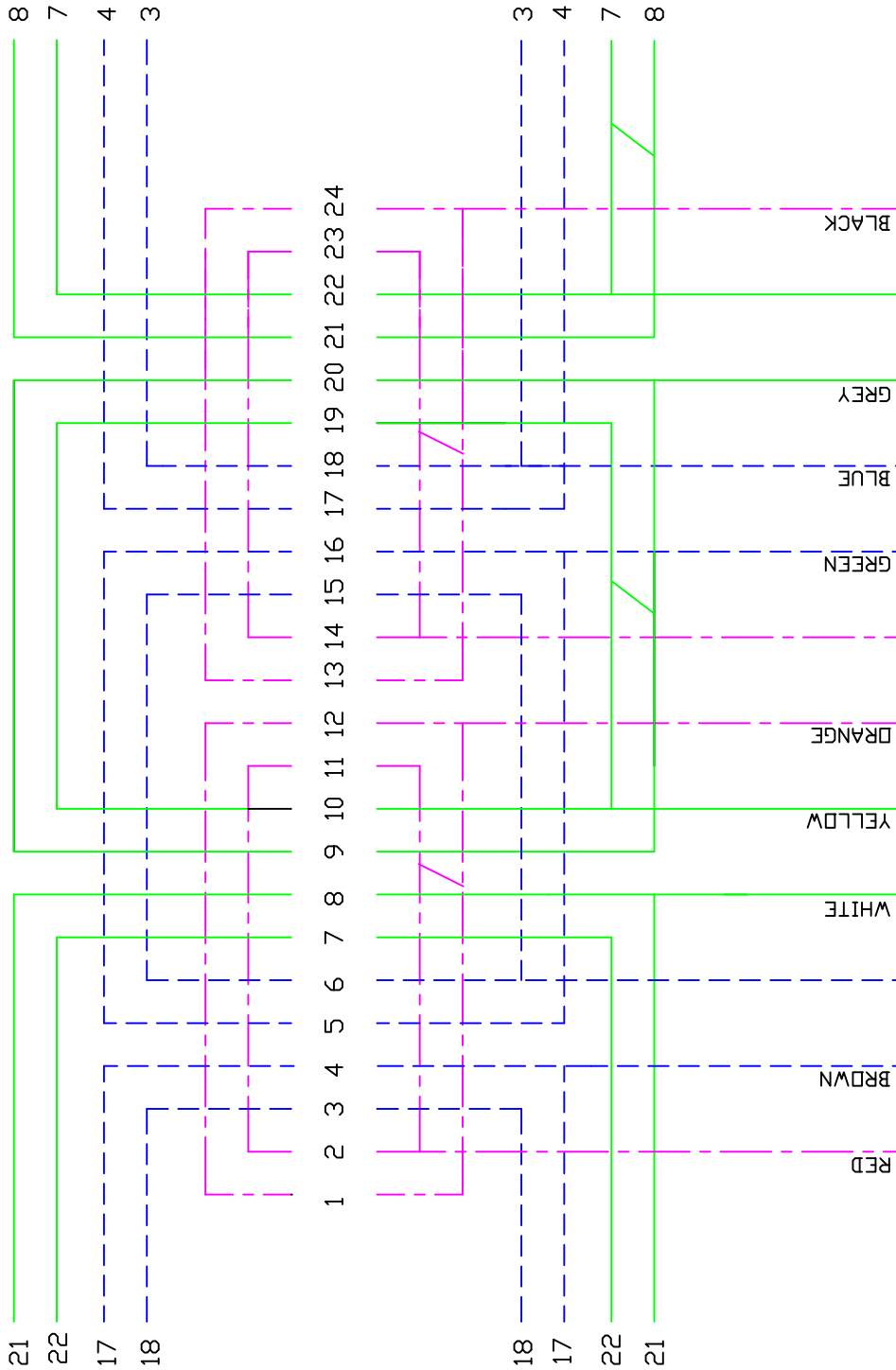

460 VOLT CONNECTION  
 JOIN A2 X - BLACK AND ORANGE  
 B2 Y - WHITE AND GREY  
 C2 Z - GREEN AND BROWN  
 POWER TO A1(RED), B1(YELLOW), C1(BLUE)



POINTS X1 Y1 Z1 ARE PERMANENTLY SHORT CIRCUITED

230 VOLT CONNECTION  
 SHORT XYZ  
 JOIN A1 A2 - RED AND BLACK-POWER  
 B1 B2 - YELLOW AND WHITE-POWER  
 C1 C2 - BLUE AND GREEN-POWER

IL - (847) 841-7867

Distributed by Pump Supply Inc

MN - (651) 758-7867

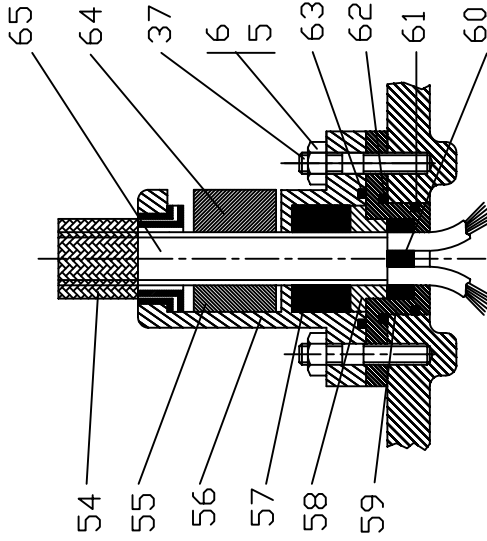

CABLE GLAND ASSY.

Illinois Location:  
(847) 841-7867

860 Church Rd Elgin, IL 60123

Minnesota Location:  
(651) 758-7867

330 Mill Bay South Suite 1511 Afton, MN

55001



TYPE	'A'	WT
NC 06M	746mm/29.5"	62Kg/137lbs
NC 08M	786mm/31.0"	67Kg/148lbs
NC 10M	796mm/31.4"	69Kg/152lbs

Moody LLC  
34750 Lencioni Avenue  
Bakersfield, CA 93308 USA  
Tel: 661-392-7600 Fax: 661-392-7601  
www.moodypump.com



TITLE:  
SECTIONAL ASSY. DRG. OF  
MODY SLUDGE PUMP

TYPE  
NC06 M  
NC08 M  
NC10 M

NAME DATE  
D.MIGUAL 22-7-2000  
CHD.  
APPD.

DRAWING No. VER. REV.  
DW/200/00 1.2 04

SHEET No. 1 OF 2

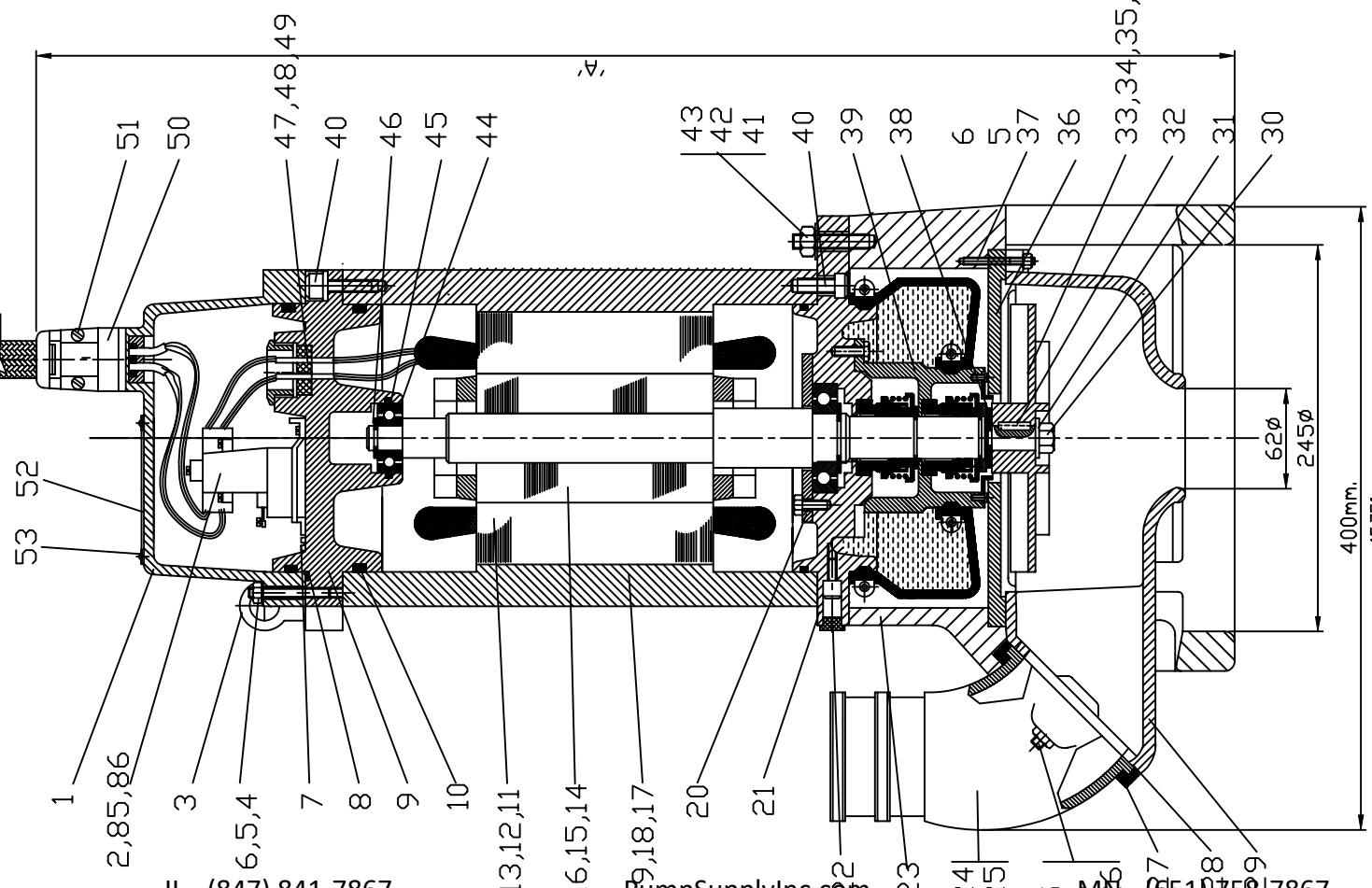

IL - (847) 841-7867

PumpSupplyInc.com

MN - (651) 758-7867

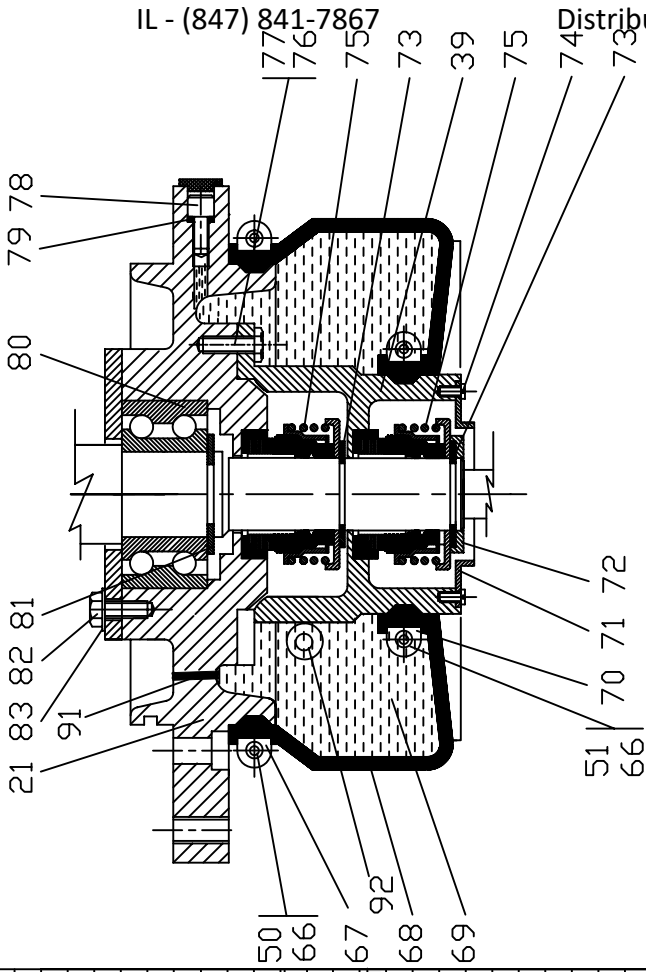

**SEALING ARRANGEMENT**

**NOTE :**

-ITEMS ARE COMMON FOR ALL MODELS, UNLESS OTHERWISE SPECIFIED.

**Illinois Location:**  
(847) 841-7867

860 Church Rd Elgin, IL 60123

**Minnesota Location:**  
(651) 758-7867

330 Mill Bay South Suite 1511 Afton, MN 55001

PumpSupplyInc.com



Mody LLC  
34750 Lencioni Avenue  
Bakersfield, CA 93308 USA  
Tel: 661-392-7600 Fax: 661-392-7601  
www.modypump.com

NAME	DATE	DRAWING No.	VER.	REV
DRN. D.M.GUTAL	105-01-2000	NC/200/00	1.2	04
CHD.				
APPD.				

TITLE: MATERIAL PARTS LIST FOR MODY SLUDGE PUMP

S.No	CODE No.	DESCRIPTION	QTY.
56	230-005-45	CABLE GLAND	1
57	260-013-66	CABLE GROMMET (NC06 M)	1
58	600-018-40	GLAND SPACER	1
59	235-005-49	CABLE GLAND BASE	1
60	260-014-66	CABLE LEAD GROMMET (NC06 M)	1
61	380-010-66	O RING	1
62	380-007-66	O RING	1
63	380-005-66	O RING	1
64	085-009-49	CABLE CLAMP	1
65	065-015-79	CABLE (NC06 M)	50'
66	370-002-21	HEX.NUT	8
67	085-008-21	DIL BAG CLAMP (BIG)	1SET
68	150-004-66	OIL DIAPHRAGM	1
69	395-002-92	OIL	1.6L
70	085-007-21	DIL BAG CLAMP SMALL	1SET
71	515-008-21	SAND GAUZE	1
72	600-035-21	CAP FOR CIRCLIP	1
73	080-005-21	CIRCLIP	2
74	525-018-21	CH.HD.SCREW	4
75	535-022-00	MECHANICAL SEAL	2
76	650-003-21	STUD	4
77	370-005-21	HEX. NUT	4
78	520-002-21	OIL PLUG	2
79	380-001-66	O RING	2
80	020-014-07	LOWER BEARING	1
81	080-006-08	CIRCLIP	1
82	045-004-21	HEX.HD.BOLT	4
83	700-002-21	WASHER	4
84	375-004-66	O RING SET	1
85	660-040-00	SEAL PROBE SENSOR	1
86	100-009-00	CONTACTOR (NC10 M )	1
87			1
88	065-016-79	CABLE (NC06, NC10 M)	50'
89	260-017-66	CABLE GROMMET (NC06, NC10 M)	1
90	260-031-66	CABLE LEAD GROMMET (NC6/10M)	1
91	260-020-66	PROBE GROMMET	1
92	660-041-00	SEAL PROBE ASSEMBLY	1
ALTERNATIVE (* ) PARTS			
93	300-045-22	IMPELLER (60HZ) (NC06360 M)	1
94	300-048-22	IMPELLER (60HZ) (NC08360 M)	1
95	300-051-22	IMPELLER (60HZ) (NC10360 M)	1

S.No	CODE No.	DESCRIPTION	QTY.
1	105-005-30	CONTACTOR COVER	1
2	100-010-00	CONTACTOR (NC06M/NC08M)	1
3	270-005-21	LIFTING HOOK	2
4	650-012-21	STUD	2
5	370-006-21	HEX. NUT	10
6	700-004-21	WASHER	10
7	525-007-40	EARTHING SCREW	2
8	380-043-66	O RING	2
9	035-017-30	UPPER BEARING BRACKET	1
10	380-028-66	O RING	2
11	620-054-00	STATOR COMPLETE (NC06350M/1)	1
12	620-055-00	STATOR COMPLETE (NC08350M/1)	1
13	620-056-31	STATOR COMPLETE (NC10350M/1)	1
14	480-047-00	ROTOR COMPLETE (NC06350M/1)	1
15	480-048-00	ROTOR COMPLETE (NC08350M/1)	1
16	480-049-00	ROTOR COMPLETE (NC10350M/1)	1
17	625-021-01	STATOR CASING (NC06350M/1)	1
18	625-022-01	STATOR CASING (NC08350M/1)	1
19	625-023-01	STATOR CASING (NC10350M/1)	1
20	037-003-30	BEARING COVER	1
21	035-029-30	LOWER BEARING BRACKET	1
22	430-007-66	OIL PLUG CAP	2
23	030-011-30	PUMP BASE	1
24	405-024-30	DISCHARGE OUTLET 4'	1
25	405-020-30	DISCHARGE OUTLET 3'	1
26	045-011-14	HEX.HD.BOLT	2
27	207-001-30	DISCHARGE OUTLET FLANGE	1
28	200-005-66	GASKET (OUTLET)	1
29	050-006-01	PUMP VOLUTE	1
30	370-014-21	HEX. NUT	1
31	695-004-21	LOCK WASHER	1
32	320-006-21	KEY	1
33	300-044-22	IMPELLER,50HZ (NC06350M/1)	1
34	300-047-22	IMPELLER,50HZ (NC08350M/1)	1
35	300-050-22	IMPELLER,50HZ (NC10350M/1)	1
36	715-005-80	WEAR PLATE	1
37	650-013-21	STUD	6
38	600-020-21	TRIMMING SPACER	1
39	545-008-45	SEAL HOUSING	1
40	650-020-21	STUD	4
41	370-008-21	HEX. NUT	4
42	700-006-21	WASHER	4
43	020-005-07	UPPER BEARING	1
44	380-013-66	O RING	1
45	080-004-08	CIRCLIP	1
46	520-003-21	CAP SCREW	4
47	260-019-66	LEAD GROMMET	1
48	365-010-40	NUT FOR GROMMET	1
49	710-008-11	WASHER FOR LEAD GROMMET	2
50	See Blowup	CABLE GLAND ASSLY.	1
51	525-010-21	CH.HD.SCREW	6
52	350-009-21	NAME PLATE	1
53	465-006-11	RIVET	4
54	227-005-21	CABLE GRIP	1
55	662-002-45	CABLE SUPPORT	1





# LIMITED WARRANTY

We warrant to our immediate customer and to the ultimate consumer that products of our manufacture will be free of defects in material and workmanship under normal use and service for the following time periods, when installed and maintained in accordance with our instructions.

**PUMPS:** One (1) year from date of installation or (18) months from date of shipment, whichever occurs first. As used herein, "the ultimate consumer" is defined as the purchaser who first uses the product after its initial installation or, in the case for product designed for non-permanent installation, the first owner who uses the product. It is the purchaser's or any sub-vendor's obligation to make known to the ultimate consumer the terms and conditions of this warranty. This warranty gives you specific legal rights, and there may also be other rights which vary from state to state. In the event the product is covered by the Federal Consumer Product Warranties Law (1) the duration of any implied warranties associated with the product by virtue of said law is limited to the same duration as stated herein, (2) this warranty is a LIMITED WARRANTY, and (3) no claims of any nature whatsoever shall be made against us, until the ultimate consumer, his successor, or assigns, notifies us in writing of the defect, and delivers the product and/or defective part(s) freight prepaid to our facility or nearest authorized service station. Some states do not allow limitations on how long an implied warranty lasts, so the above limitation may not apply. **THE SOLE AND EXCLUSIVE REMEDY FOR BREACH OF ANY AND ALL WARRANTIES WITH RESPECT TO ANY PRODUCT SHALL BE TO REPLACE OR REPAIR AT OUR ELECTION, FOB POINT OF MANUFACTURE OR AUTHORIZED REPAIR STATION, SUCH PRODUCTS AND/OR PARTS AS PROVEN DEFECTIVE. THERE SHALL BE NO FURTHER LIABILITY, WHETHER BASED ON WARRANTY, NEGLIGENCE OR OTHERWISE.**

Unless expressly stated otherwise, guarantees in the nature of performance specifications furnished in addition to the foregoing material and workmanship warranties on a product manufactured by *Mody*, if any, are subject to laboratory tests corrected for field performance. Any additional guarantees, in the nature of performance specifications must be in writing and such writing must be signed by our authorized representative. Due to inaccuracies in field testing if a conflict arises between the results of field testing conducted by or for user, and laboratory tests corrected for field performance, the latter shall control. Components or accessories supplied by us but manufactured by others are warranted only to the extent of and by the terms and conditions of the original manufacturer's warranty.

**RECOMMENDATIONS FOR SPECIAL APPLICATIONS OR THOSE RESULTING FROM SYSTEMS ANALYSES AND EVALUATIONS WE CONDUCT, WILL BE BASED ON OUR BEST AVAILABLE EXPERIENCE AND PUBLISHED INDUSTRY INFORMATION. SUCH RECOMMENDATIONS DO NOT CONSTITUTE A WARRANTY OF SATISFACTORY PERFORMANCE AND NO SUCH WARRANTY IS GIVEN.**

This warranty shall not apply when damage is caused by (a) improper installation, (b) improper voltage, (c) lightning, (d) sand or other abrasive materials, (e) scale or corrosion build-up due to excessive chemical content. Any modification of the equipment will also void the warranty. We will not be responsible for loss, damage or labor cost due to interruption of service caused by defective parts. Neither will we accept charges incurred by others without our prior written approval. This warranty is void if our inspection reveals the product was used in a manner inconsistent with normal industry practice and/or our specific recommendations. The purchaser is responsible for communication of all necessary information regarding the application and use of the product. **UNDER NO CIRCUMSTANCES WILL WE BE RESPONSIBLE FOR ANY OTHER DIRECT OR CONSEQUENTIAL DAMAGES, INCLUDING BUT NOT LIMITED TO LOST PROFITS, LOST INCOME, LABOR CHARGES, DELAYS IN PRODUCTION, IDLE PRODUCTION, WHICH DAMAGES ARE CAUSED BY ANY DEFECTS IN MATERIAL, AND/OR WORKMANSHIP AND/OR DELAYS IN SHIPMENT. THIS WARRANTY IS EXPRESSLY IN LIEU OF ANY OTHER EXPRESS OR IMPLIED WARRANTY, INCLUDING ANY WARRANTY OF MERCHANTABILITY OR FITNESS FOR A PARTICULAR PURPOSE.**

No rights extended under this warranty shall be assigned to any person, whether by operation or otherwise, without our prior written approval.

**Mody Pumps Inc.:** 2166 Zeus Court, Bakersfield, CA 93308 Tel.: (661) 392-7600 Fax: (661) 392-7601