

mody

ELECTRIC SUBMERSIBLE ALL STAINLESS STEEL PUMPS

NON-CLOG SLUDGE PUMP SERIES ALL STAINLESS STEEL 50/60 HZ

**PORTABLE ELECTRIC
SUBMERSIBLE SLUDGE PUMP
FOR
CORROSIVE & ABRASIVE
APPLICATIONS**

PH Range of 2-10

6 HP (4.5kW)

**NC 06350M/SS - 50Hz
NC 06360M/SS - 60Hz
4" (100mm) Flange or Hose**

8 HP (6kW)

**NC 08350M/SS - 50Hz
NC 08360M/SS - 60Hz
4" (100mm) Flange or Hose**

10 HP (7.5kW)

**NC 10350M/SS - 50Hz
NC 10360M/SS - 60Hz
4" (100mm) Flange or Hose**

DESIGN ADVANTAGES

- Available in all Stainless Steel materials for corrosive and abrasive applications. These pumps are capable of handling contaminated fluids typical at most landfills, nuclear power plants, mines, paper & pulp industries.
- Non-Clog Sludge Series with 2 1/2" solid handling capabilities to meet the demands of the most critical applications.
- Choice of impeller materials:
 - 1) 316 Stainless Steel for sea water and corrosive applications and;
 - 2) Nitride Hardened 410 Stainless Steel for abrasive applications. (Standard)
- Choice of Mechanical Seals:
 - 1) Tandem Mechanical Seals, TC/TC (+ ph 5) and;
 - 2) Tandem Mechanical Seals, SC/SC (- ph 5) (Standard)



Illinois Location:

(847) 841-7867
860 Church Rd Elgin, IL 60120

Minnesota Location:

(651) 758-7867
330 Mill Bay South Suite :
Afton, MN 55001

PumpSupplyInc.com



**PUMP SUPPLY
INCORPORATED**

mody

ELECTRIC SUBMERSIBLE ALL STAINLESS STEEL PUMPS

NON-CLOG | SLUDGE SERIES

6HP(4.5kW) | 8HP(6kW) | 10HP(7.5kW)

Model	50/60Hz
	A
NC-06	29.5"
NC-08	31.0"
NC-10	31.5"

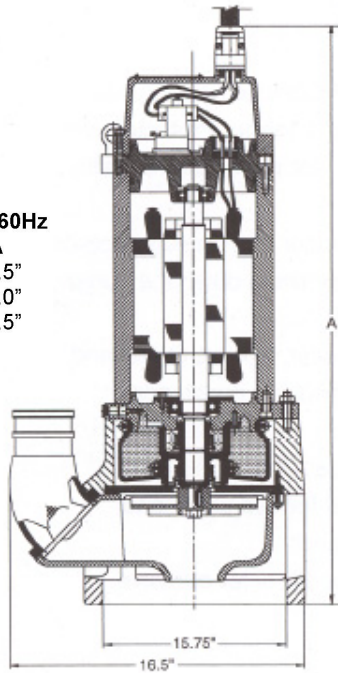

Max. Sphere Size 2.5"/65mm

PERFORMANCE CURVES

MODEL: NC 06M/08M/10M (50/60 Hz)

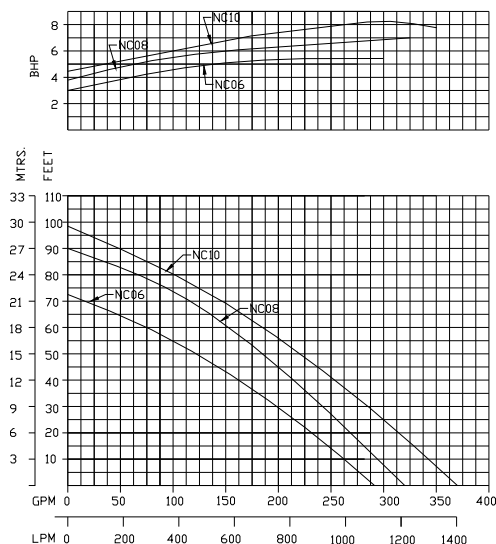

NON-CLOG SS SERIES

MATERIALS OF CONSTRUCTION AND ENGINEERING DATA

MOTOR

2-pole induction **continuous rated** motor with squirrel cage rotor.
Stator insulation class 'H' (180°C)
Speed : 3400 RPM @ 60 Hz, 2800 RPM @ 50 Hz
Power Rating : 6/8/10HP @ 60 Hz, 4.5/6/7.5kW @ 50Hz Full Load
Current FLA: 9.8, 12, 14 Amps @ 460v. 11, 13.8, 16 Amps @ 400v.
Max. temperature of the pump liquid : 104°F/40°C
Max. start/stop per hour : 15

POWER SUPPLY

3 phase, 50/60 Hz, AC Supply. Available in any voltage frequency combination. (208/220/230/380/415/460/575/1000V) Moisture sensor available in 200/400v configurations only. Built in Contactor which trips at excessively high motor temperatures through bimetallic switches in the winding.

BALL BEARINGS

The rotor shaft is carried in two single row, deep groove ball bearings.
The bearings are enclosed with high temperature grease-containing special Anti-corrosion additive.

POWER CABLE

Waterproof/oil proof, rubber-insulated, neoprene-sheathed copper conductor flexible cable, 50ft. (15m) length standard. Type SOOW in North America, EPR in the Middle East and HO7RN in the EU.

SHAFT SEAL

Tandem Silicon Carbide/Silicon Carbide and Silicon Carbide/Silicon Carbide Mechanical seals wholly enclosed in a pressure compensated oil chamber.

CORROSION RESISTANT

Stator Casing: 316 Stainless Steel
Wear plate: 316 Stainless Steel
Shaft: 431 Stainless Steel
Hardware: 316 Stainless Steel
Impeller: Nitride Hardened 410SS to 56HRC or 316SS
Volute: 316 Stainless Steel
pH Range 2 - 10

SUBMERGENCE

Submergence below liquid surface min 8" (127mm) max. 50' (15m).

WEIGHTS (Approx. without cable)

NC 06/SS:	167 lbs. (76Kg)
NC 08/SS:	185 lbs. (84Kg)
NC 10/SS:	194 lbs. (88Kg)



PUMP SUPPLY
INCORPORATED

Due to continuous product development, specifications are subject to change without notice.
01.12.Rev.0