

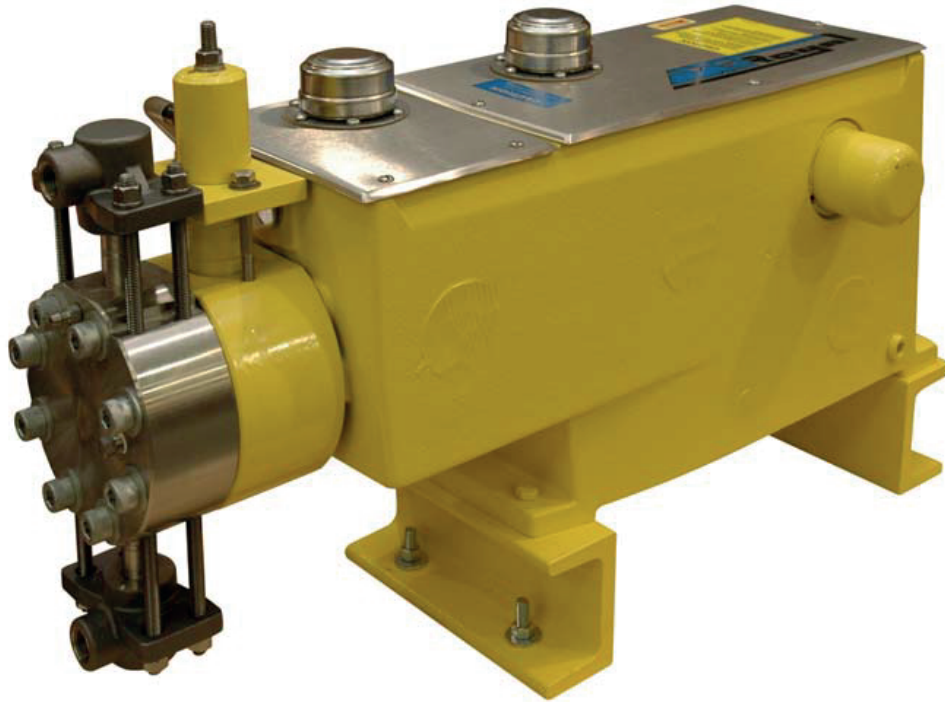

*an Accudyne Industries brand*



**PUMP SUPPLY**  
INCORPORATED



# **MILROYAL<sup>®</sup> B**

## **High Performance Diaphragm Liquid End (HPD) - Low Flow**

### **IOM Manual**

Manual No : 54149

Rev. : 00

Rev. Date : 10/2015



*an Accudyne Industries brand*

**Illinois Location:**  
(847) 841-7867  
860 Church Rd Elgin, IL 60120

**Minnesota Location:**  
(651) 758-7867  
330 Mill Bay South Suite  
Afton, MN 55001

PumpSupplyInc.com



The image contains a map of the United States with the states of Illinois and Minnesota highlighted. Two stars are placed on the map: one in the western part of Illinois and one in the southern part of Minnesota. Below the map is the logo for Pump Supply Incorporated, which consists of a blue triangle containing the letters 'P' and 'S' in white, followed by the text 'PUMP SUPPLY INCORPORATED' in a bold, sans-serif font.

## **PRECAUTIONS**

The following precautions should be taken when working with metering pumps.  
Please read this section carefully prior to installation.

### **Protective Clothing**



ALWAYS wear protective clothing, face shield, safety glasses and gloves when working on or near your metering pump. Additional precautions should be taken depending on the solution being pumped. Refer to **Safety Data Sheets** for the solution being pumped.

### **Hearing Protection**



It is recommended that hearing protection be used if the pump is in an environment where the time - weighted average sound level (TWA) of 85 decibels is exceeded. (as measured on the A scale - slow response)

### **Electrical Safety**



- Remove power and ensure that it remains off while maintaining pump.
- **DO NOT FORGET TO CONNECT THE PUMP TO EARTH.**
- Electric protection of the motor (Thermal protection or by means of fuses) is to correspond to the rated current indicated on the motor data plate.

### **Liquid Compatibility**



Verify if the materials of construction of the wetted components of your pump are recommended for the solution (chemical) to be pumped.

### **Pumps Water “Primed”**



All pumps are tested with water at the factory. If your process solution is not compatible with water, flush the **Pump Head Assembly** with an appropriate solution before introducing the process solution

### **Plumbing and Electrical Connections**



Always adhere to your local plumbing and electrical codes.

### **Line Depressurization**



To reduce the risk of chemical contact during disassembly or maintenance, the suction and discharge lines should be depressurized before servicing.

### **Over Pressure Protection**





To ensure safe operation of the system it is recommended that some type of safety/pressure-relief valve be installed to protect the piping and other system components from damage due to over-pressure.



**Lifting**

This manual should be used as a guide only - Follow your company's recommended lifting procedures. It is not intended to replace or take precedence over recommendations, policies and procedures judged as safe due to the local environment than what is contained herein. Use lifting equipment that is rated for the weight of the equipment to be lifted.

<p><b><u>Illinois Location:</u></b> (847) 841-7867 860 Church Rd Elgin, IL 60120</p>	
<p><b><u>Minnesota Location:</u></b> (651) 758-7867 330 Mill Bay South Suite Afton, MN 55001</p>	
<p>PumpSupplyInc.com</p>	





**TABLE OF CONTENTS**



**PUMP SUPPLY  
INCORPORATED**

**SECTION 1 - DESCRIPTION . . . . . 1**

    1.1 GENERAL . . . . . 1

    1.2 DESCRIPTION . . . . . 1

    1.3 PRINCIPLE OF OPERATION . . . . . 1

    1.4 MODEL CODING . . . . . 3

    1.5 SPECIFICATIONS . . . . . 3

**SECTION 2 - INSTALLATION . . . . . 5**

    2.1 UNPACKING . . . . . 5

    2.2 STORAGE . . . . . 5

        2.2.1 Short Term Storage (Less than 6 Months) . . . . . 5

        2.2.2 Long Term Storage (Longer than 6 Months) . . . . . 5

        2.2.3 Pump Drive and Gearboxes . . . . . 5

        2.2.4 Pump Liquid Ends . . . . . 5

        2.2.5 Pneumatic, Electrical and Electronic Equipment . . . . . 6

    2.3 SAFETY PRECAUTIONS . . . . . 6

    2.4 MOUNTING . . . . . 6

    2.5 PIPING CONNECTIONS . . . . . 7

    2.6 NPSH CONSIDERATIONS . . . . . 7

    2.7 TYPICAL PIPING . . . . . 7

    2.8 LIQUID END CONVERSION PROCEDURE . . . . . 7

**SECTION 3 - OPERATION . . . . . 8**

    3.1 PUMP START-UP PROCEDURE . . . . . 8

    3.2 RELIEF VALVE ADJUSTMENT . . . . . 11

**SECTION 4 - MAINTENANCE . . . . . 13**

    4.1 RECOMMENDED SPARE PARTS . . . . . 13

    4.2 RETURNING UNITS TO THE FACTORY . . . . . 13

    4.3 ROUTINE PREVENTIVE MAINTENANCE . . . . . 13

    4.4 MARS REFILL VALVE . . . . . 13

    4.5 HYDRAULIC OIL REPLACEMENT . . . . . 14

    4.6 CHECK VALVE MAINTENANCE . . . . . 14

        4.6.1 Cleaning Fouled Check Valves . . . . . 14

        4.6.2 Check Valve Replacement (General) . . . . . 14

        4.6.3 Disassembly . . . . . 14

        4.6.4 Reassembly . . . . . 15

    4.7 DIAPHRAGM REPLACEMENT . . . . . 15

        4.7.1 Removing Liquid End . . . . . 15

        4.7.2 Removing Diaphragm . . . . . 16

        4.7.3 Replacing Diaphragm . . . . . 16

        4.7.4 Reinstalling Liquid End . . . . . 17

    4.8 CORRECTIVE MAINTENANCE . . . . . 17

        4.8.1 Relief Valve Assembly . . . . . 17

**SECTION 5 - TROUBLESHOOTING GUIDE . . . . . 18**

**SECTION 6 - PARTS** ..... 19

6.1 GENERAL ..... 19

6.2 ILLUSTRATED PARTS LIST ..... 19

6.3 PARTS LIST FOR LOW-FLOW LIQUID END, 7/16 PLUNGER ..... 22

6.4 PARTS LIST FOR LOW-FLOW LIQUID END, 9/16 PLUNGER ..... 25

6.5 PARTS LIST FOR LOW-FLOW LIQUID END, 5/8 PLUNGER ..... 28

6.6 PARTS LIST FOR LOW-FLOW LIQUID END, 7/16, 9/16, AND 5/8 PLUNGER WITH RUPTURE  
DETECTION ..... 32

**LIST OF ILLUSTRATIONS**

FIGURE 1. Principle of Operation-Suction ..... 2

FIGURE 2. Principle of Operation-Discharge ..... 2

FIGURE 3. Low-Flow High Performance Diaphragm (HPD) Liquid End Model Code ..... 4

FIGURE 4. Milroyal® B HPD Low-Flow Liquid End Assembly (DWG 102-2095-0010)(Sheet 1 of 2) ..... 20

FIGURE 4. Detail of Contour Plate Assembly, Mars Valve Assembly, and Strainer (Sheet 2 of 2) ..... 21

FIGURE 5. Milroyal® B HPD Low-Flow With Rupture Detection (DWG 102-2095-0013)..... 31

**Illinois Location:**  
 (847) 841-7867  
 860 Church Rd Elgin, IL 60120

**Minnesota Location:**  
 (651) 758-7867  
 330 Mill Bay South Suite  
 Afton, MN 55001

PumpSupplyInc.com



---

## SECTION 1 - DESCRIPTION

---

### 1.1 GENERAL

This instruction manual is designed to serve as a supplement to instruction manual 53940, which provides both general information and specific instructions for installing, operating, and maintaining Milton Roy pumps. This manual covers the optional Milroyal® B Low-Flow High Performance Diaphragm Liquid End (HPD). This liquid end can be purchased in plunger diameters 7/16", 9/16" and 5/8". Do not rely on this manual alone when installing, maintaining and operating Milton Roy pumps.

### 1.2 DESCRIPTION

The low-flow HPD liquid end combines all of the best characteristics of traditional liquid ends into one technologically advanced design. Its operating characteristics and simplicity of operation make it the best liquid end to consider first for high pressure metering pump applications.

Milton Roy's low-flow HPD liquid end overcomes many of the Net Positive Suction Head (NPSH) restrictions associated with conventional disc diaphragm metering pumps. This is accomplished by a patented Mechanically Actuated Refill System (MARS) that eliminates the process side support plate and lowers NPSH requirements.

The MARS also does away with the need for field adjustment of the refill mechanism by automatically compensating for process liquid modifications. This, combined with removable check valves, makes the low-flow HPD an ideal choice for any process in which downtime is critical.

The low-flow HPD features a preformed, PTFE faced elastomer diaphragm that is compatible with a wide range of process liquids and chemicals. The composite diaphragm also offers extended life over conventional designs.

The low-flow HPD is particularly suitable for pumping costly, aggressive or hazardous liquids without leakage.

### 1.3 PRINCIPLE OF OPERATION (FIGURES 1 AND 2)

The mechanical drive system of the pump drives the piston back and forth in the High Performance Diaphragm (HPD) liquid end supplied with the pump. At the start of a suction stroke, the plunger moves away from the liquid end, drawing hydraulic fluid with it. As the hydraulic fluid is drawn back, the flexible diaphragm follows, lowering the pressure on the process fluid in the liquid end. This pressure causes the fluid to flow inward, lifting the suction ball check, and allowing process fluid to pass through the suction line into the diaphragm head. At the same time, the discharge ball check is pulled closed, blocking flow back through the discharge line. Minimum back pressure in discharge line of 30 psi is required.

At the end of the suction stroke, the process reverses, beginning the discharge stroke. Now the plunger moves forward, pushing hydraulic fluid before it. The hydraulic oil must therefore press against the diaphragm, flexing it forward and raising the pressure on the process fluid in the liquid end. This pressure causes the process fluid to flow outward, forcing the discharge ball check open and the suction ball check to seat, blocking back flow through the suction line. The process fluid flows out of the diaphragm head and into the discharge line. This suction/discharge action is repeated with every stroke of the pump plunger, and is the direct cause of the pumping action.





## SECTION 1 - DESCRIPTION

As the pump operates, a small quantity of hydraulic oil is continuously bled through the air bleed/relief valve. After a while, this results in a shortage of hydraulic oil in the displacement chamber. When this happens, the diaphragm will be pulled tight against the contour plate, and part of the diaphragm will press against the patented Mechanically Actuated Refill System (MARS) valve. Now, when the plunger draws back, a vacuum is created in the displacement chamber. These two factors (diaphragm pressing against MARS valve & a vacuum in the displacement chamber) must occur together to trigger the MARS valve.

When both of these conditions are met, the MARS valve is forced to its rearward position, and the poppet opens, allowing hydraulic oil from the reservoir to enter and replenish the lost oil. In this manner, proper hydraulic balance is constantly maintained in the displacement chamber.

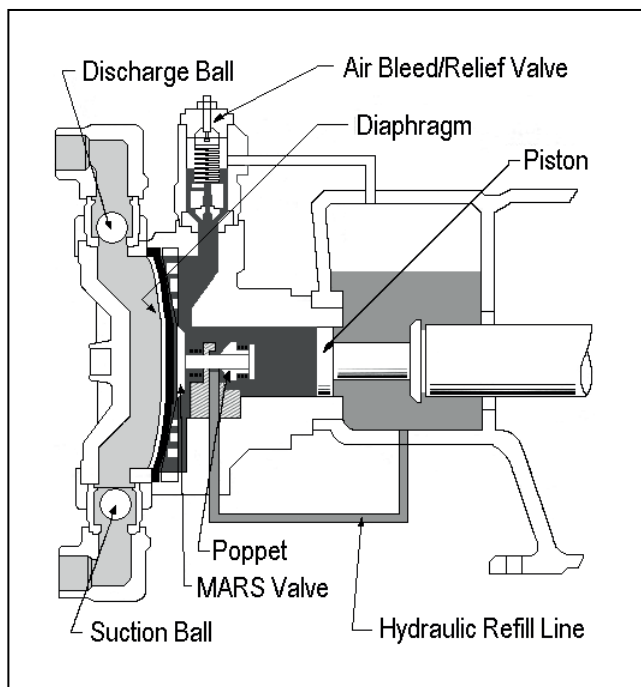

Figure 1. Principle of Operation-Suction.

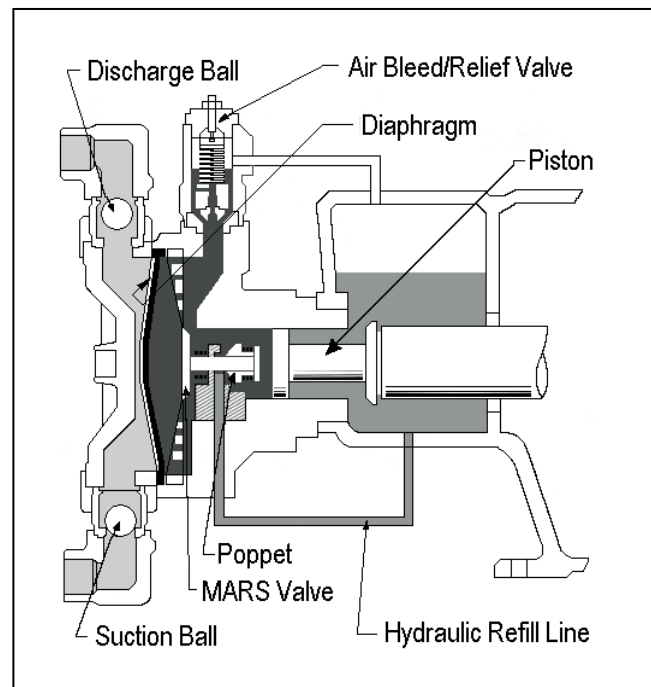

Figure 2. Principle of Operation-Discharge.

**Illinois Location:**

(847) 841-7867

860 Church Rd Elgin, IL 61

**Minnesota Location:**

(651) 758-7867

330 Mill Bay South Suite  
Afton, MN 55001

PumpSupplyInc.com

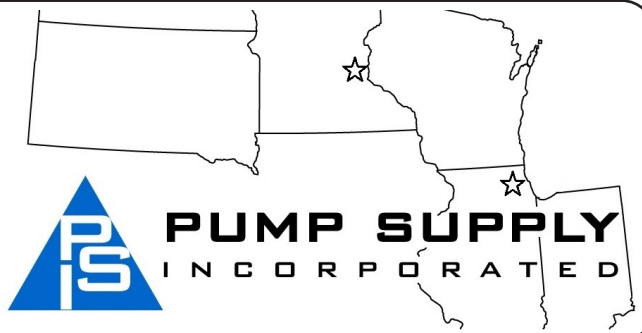



# SECTION 1 - DESCRIPTION

## 1.4 MODEL CODING

The presence of an low-flow HPD liquid end on a Milroyal® B pump is indicated by an “H” in the third position of the pump model code (Figure 3) followed by 07, 09, or 10 (XXH-09X-XX XX XX XX XX XX XX XX). This model code can be found on the data plate attached to the pump. For more information on pump model coding, see the appropriate pump data sheet (www.miltonroy.com). The above model code represents a standard configured pump. Special configured pumps are also identified by an “H” in the third position of the pump model code followed by 07, 09, or 10 followed by a 1, 5, or 6 (liquid end material) followed by an X (special) followed by a four digit number (XXH- 091X0036).

## 1.5 SPECIFICATIONS

<b>Plunger Diameters:</b>	Milroyal® B- 7/16”, 9/16”, 5/8”
<b>Pressures:</b>	Up to 3,625 psi (250 bar)
<b>Flow Range:</b>	2.0 - 14 gph (7.6 - 53 lph)
<b>Materials of Construction:</b>	316 SS, Alloy 20, Alloy C22 (Custom Materials Available)
<b>Flow Rates and Pump Model Coding:</b>	See www.miltonroy.com Data Sheets for Download Milroyal® B Low-Flow PD 3641 and PS 3603
<b>Stroke Length Steady State Accuracy/ Turndown Ratio:</b>	+/-1% steady state accuracy over 10:1 turndown ratio (w/constant speed drive)
<b>Liquid Temperature:</b>	-20°F (-28.9°C) to 250°F (121.1°C)
<b>Net Positive Inlet Pressure:</b>	3 PSIA minimum.

**Illinois Location:**  
(847) 841-7867  
860 Church Rd Elgin, IL 60120

**Minnesota Location:**  
(651) 758-7867  
330 Mill Bay South Suite :  
Afton, MN 55001

PumpSupplyInc.com





**PUMP SUPPLY**  
INCORPORATED



# SECTION 1 - DESCRIPTION

## Hydraulic Fluid:

Zurnpreen 15A - - Type A, ATF (ISO 32 an equivalent)

## Ball Checks:

Double ball checks in suction and discharge.

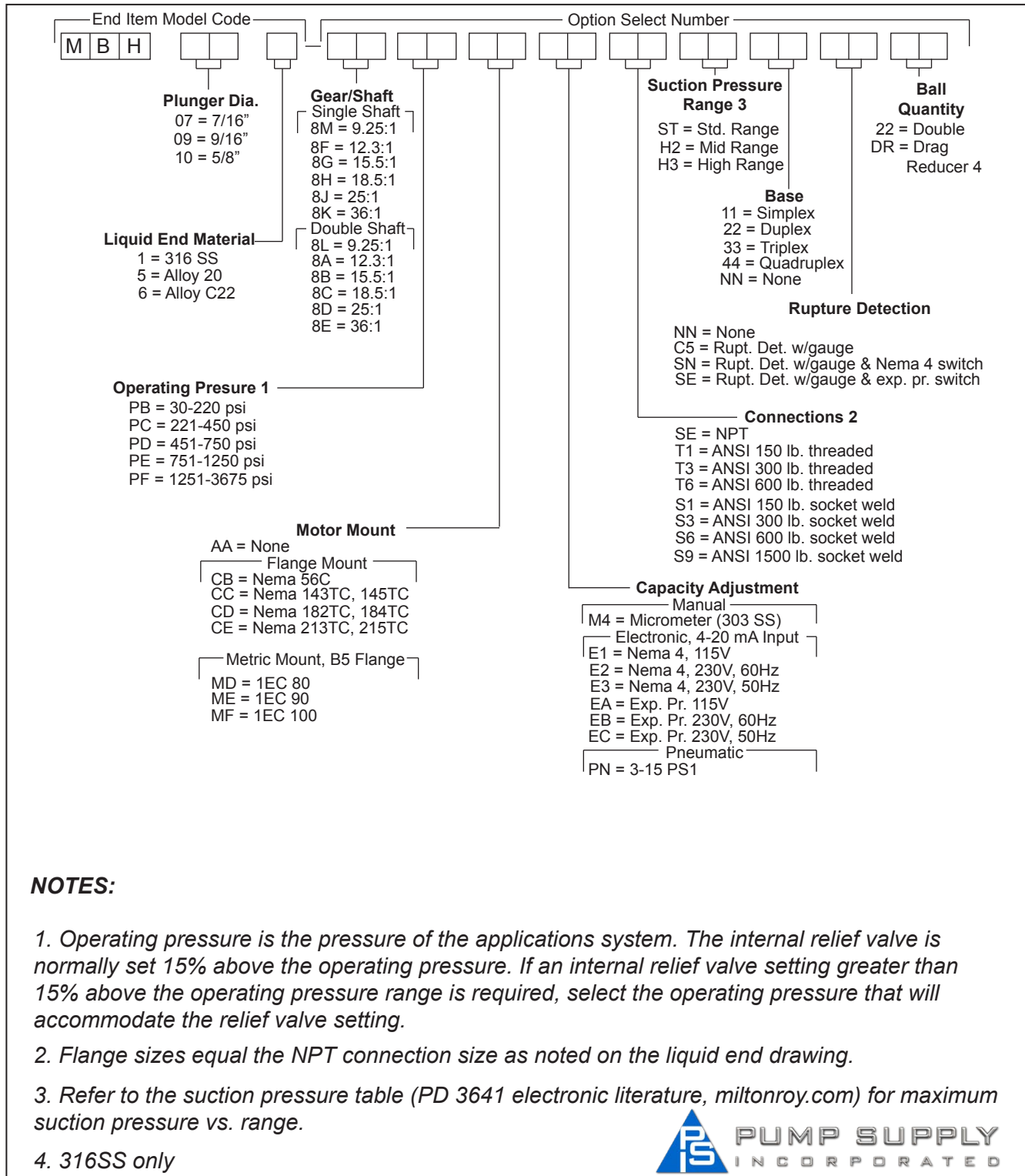

## NOTES:

1. Operating pressure is the pressure of the applications system. The internal relief valve is normally set 15% above the operating pressure. If an internal relief valve setting greater than 15% above the operating pressure range is required, select the operating pressure that will accommodate the relief valve setting.
2. Flange sizes equal the NPT connection size as noted on the liquid end drawing.
3. Refer to the suction pressure table (PD 3641 electronic literature, miltonroy.com) for maximum suction pressure vs. range.
4. 316SS only



Figure 3. Low-Flow High Performance Diaphragm (HPD) Liquid End Model Code.



## SECTION 2 - INSTALLATION

### 2.1 UNPACKING

Pumps are shipped f.o.b. from the factory and the title passes to the customer when the carrier signs for receipt of it. The customer, therefore, must file damage claims with the carrier.

The shipping crate should be carefully examined upon receipt from the carrier to be sure there is no obvious damage to the contents. Open the crate carefully, as there are sometimes accessory items fastened to the inside of the crate that may be lost or damaged. Examine all material inside crate and check against the packing list to be sure that all items are accounted for and undamaged.

**▲ CAUTION** THE FOLLOWING PROCEDURES SHOULD BE FOLLOWED WHEN A PUMP IS NOT PUT INTO SURVICE UPON RECEIPT.

### 2.2 STORAGE

#### 2.2.1 Short Term Storage (Less than 6 Months)

It is preferable to store the material under a shelter in its original package to protect it from adverse weather conditions. In condensing atmospheres, follow the long term storage procedure.

#### 2.2.2 Long Term Storage (Longer than 6 Months)

The primary consideration in storage of pump equipment is to prevent corrosion of external and internal components. This corrosion is caused by natural circulation of air as temperature of the surroundings change from day to night, day to day, and from season to season. It is not practical to prevent this circulation which carries water vapor and other corrosive gasses, so it is necessary to protect internal and external surfaces from their effects to the greatest extent possible.

When the instructions given in this section are completed, the equipment is to be stored in a shelter; protected from direct exposure to weather. The prepared equipment should be covered with a plastic sheet or a tarpaulin, but in a manner which will allow air circulation and prevent capture of moisture. Equipment should be stored 12 inches or more above the ground.

If equipment is to be shipped directly from Milton Roy into long term storage, contact Milton Roy to arrange for factory preparation.

#### 2.2.3 Pump Drive and Gearboxes

A. Flood the gearbox compartment with a high grade lubricating oil/rust preventative such as Mobil Oil Corporation product Mobilarma 524. Fill the compartment completely to minimize air space and water vapor condensation. After storage, drain this material and refill the equipment with the recommended lubricant for equipment commissioning.

B. Remove drive motors and mounting adapters, and brush all unpainted metal surfaces with multipurpose grease (NLGI grade 2 or 3). Store these unattached.

#### 2.2.4 Pump Liquid Ends

A. Flood the front compartment of the pump housing (if the model has a front compartment) with a high grade Lubricating Oil/Rust Preventative such as Mobil Oil Corporation product "Mobilarma 524."

1. If the pump has a diaphragm style liquid end, fill the pump-housing compartment all the way to minimize airspace and water vapor condensation.





## SECTION 2 - INSTALLATION

2. Most of the liquid ends themselves are constructed of inherently corrosion resistant materials and require no applied corrosion inhibitor. If they are NOT naturally resistant (test the threaded or flanged inlet and outlet connections - if they have little or no magnetic property, they are resistant) they should be flush filled with a corrosion inhibiting and non-freezing liquid which is compatible with the final pumped process chemical. Flush and fill with inhibitors such as "Mobilarna 524" or with a commercial automotive antifreeze coolant. The pump head contains one way check valves, so flush in a direction into the suction (bottom) connection, and out the discharge (top) connection.

B. Cap or plug all openings to capture the inhibiting fluid, and to prevent animals and insects from building nests.

### 2.2.5 Pneumatic, Electrical and Electronic Equipment

- A. Motors should be prepared in the manner prescribed by their manufacturer. If information is not available, dismount and store motors as indicated in step "B" below.
- B. For all pneumatic and electrical equipment, place packets of Vapor Phase Corrosion Inhibitor (VPCI) inside of the enclosure, then place the entire enclosure, with additional packets, inside a plastic bag. Seal the bag tightly closed. Contact Milton Roy Service Department for recommended VPCI materials.

#### Illinois Location:

(847) 841-7867  
860 Church Rd Elgin, IL 60123

#### Minnesota Location:

(651) 758-7867  
330 Mill Bay South Suite 1511 Afton, MN 55001

PumpSupplyInc.com

### 2.3 SAFETY PRECAUTIONS

**⚠ WARNING** WHEN INSTALLING, OPERATING, AND MAINTAINING THIS LOW-FLOW HPD LIQUID END, KEEP SAFETY CONSIDERATIONS FOREMOST. USE PROPER TOOLS, PROTECTIVE CLOTHING, AND EYE PROTECTION WHEN WORKING ON THE EQUIPMENT AND INSTALL THE EQUIPMENT WITH A VIEW TOWARD ENSURING SAFE OPERATION. FOLLOW THE INSTRUCTIONS IN THIS MANUAL AND TAKE ADDITIONAL SAFETY MEASURES APPROPRIATE TO THE LIQUID BEING PUMPED. BE EXTREMELY CAREFUL IN THE PRESENCE OF HAZARDOUS SUBSTANCES (E.G., CORROSIVES, TOXINS, SOLVENTS, ACIDS, CAUSTICS, FLAMMABLES, ETC).

**⚠ CAUTION** THE PERSONNEL RESPONSIBLE FOR INSTALLATION, OPERATION AND MAINTENANCE OF THIS EQUIPMENT MUST BECOME FULLY ACQUAINTED WITH THE CONTENTS OF THIS MANUAL.

**⚠ CAUTION** ANY SERVICING OF THIS EQUIPMENT MUST BE CARRIED OUT WHEN THE UNIT IS STOPPED AND ALL PRESSURE HAS BEEN BLED FROM THE LIQUID END. SHUT-OFF VALVES IN SUCTION AND DISCHARGE SIDES OF THE LIQUID END SHOULD BE CLOSED WHILE THE UNIT IS BEING SERVICED. ACTIONS SHOULD BE TAKEN TO ELIMINATE THE POSSIBILITY OF ACCIDENTAL START-UP WHILE SERVICING IS TAKING PLACE. A NOTICE SHOULD BE POSTED BY THE POWER SWITCH TO WARN THAT SERVICING IS BEING CARRIED OUT ON THE EQUIPMENT. SWITCH OFF THE POWER SUPPLY AS SOON AS ANY FAULT IS DETECTED DURING OPERATION (EXAMPLES: ABNORMALLY HIGH DRIVE TEMPERATURE, UNUSUAL NOISE, DIAPHRAGM FAILURE).

### 2.4 MOUNTING

The low-flow HPD liquid end is usually shipped already mounted to the appropriate pump. Mounting, therefore, is simply a matter of securing the pump to a safe, level surface. For further information on proper pump mounting, see 53940 Milroyal® B drive pump instruction manual.





## SECTION 2 - INSTALLATION

### 2.5 PIPING CONNECTIONS (General)

General piping instructions are given in the pump drive instruction manual (53940). No reciprocating plunger pump can be expected to perform satisfactorily unless those recommendations are followed.

**NOTE:**

*Maximum safety and reliability may be ensured by protecting liquid ends and piping with an external relief valve installed in the system discharge line.*

### 2.6 NPSH CONSIDERATIONS

The low-flow HPD liquid end is far superior to conventional diaphragm liquid ends for suction lift and many other NPSH critical applications. It's patented diaphragm and advanced design refill mechanism give this liquid end truly high performance in these applications.

For more NPSH information, refer to Milton Roy web site ([www.miltonroy.com](http://www.miltonroy.com)) for aid in evaluating applications for this liquid end.

### 2.7 TYPICAL PIPING

In order to adjust the low-flow HPD relief valve, it is necessary to have a pressure gauge and a shut off valve installed in the discharge line. The pressure gauge must have a higher range than the desired pump relief pressure, and should be installed as close to the pump discharge connection as possible. The shut off valve should be installed downstream of the pressure gauge. These items are not required for normal operation, but for ease of pump maintenance and adjustment, it is suggested that they be permanently piped into the line.

### 2.8 LIQUID END CONVERSION PROCEDURE

Plunger Size	Code	Part Number
7/16	7	30333
9/16	9	30347
5/8	10	30334

**Table 1. Retrofit Kits**

The following is the procedure for converting from a packed plunger or disc diaphragm liquid end to the low-flow HPD liquid end on a Milroyal® B pump. The procedure assumes that a pre-assembled liquid end is being installed.

1. Remove packed plunger, or disc diaphragm liquid end assembly from pump (see pump drive manual disassembly instructions in instruction manual (53943) for the old packed plunger, the 54150 for the new packed plunger, and the 54145 for the disc diaphragm). Remove plunger adapter, gland cap, gland studs or bolts, and funnel if applicable.

**NOTE:**

*An additional crosshead seal is necessary when converting from a packed plunger to a hydraulically actuated diaphragm. This may be a good time to replace both seals. If necessary, follow the instructions in the drive manual, otherwise, do the following.*

2. Place additional lip-type seal (330), with lip facing towards liquid end, over crosshead. Position seal back to back with original seal in crosshead seal bore. Be careful not to damage seal lip during installation.

**NOTE:**

*Do not damage the sealing surface of the crosshead. Make sure the I. D. of the pipe is clean and free of burrs.*





## SECTION 2 - INSTALLATION

- Place a length of 2 1/2" O. D. schedule 40 pipe over crosshead and against seal. Using a soft mallet, strike pipe to drive seal into crosshead seal bore until new seal is flush with casing face.

**NOTE:**

*Laying a cloth and/or a magnet in casing to catch chips while drilling is advisable. Also, protect the crosshead from damage during this operation.*

- Drill a 1/4" diameter hole off vertical center line 2 1/2" below top machined edge of pump casing wall in which seals are installed.
- Remove all dirt, chips, and debris from pump casing and clean liquid end mounting face on pump casing.
- Loosely install plunger adapter (2020) in crosshead.

**NOTE:**

*Before installing liquid end identify type of housing. When the front end of the pump housing has 6 bolt holes the adapter and "O"-ring are NOT used. Five holes requires a gasket. When the front end of the pump housing has only two bolt holes, use adapter ring, "O"-ring, and gasket with matching 'ears'.*

- Carefully fit liquid end assembly into casing bore while guiding plunger assembly into hole in plunger adapter.
- Thread bolts (2050) into displacement chamber from inside pump catchall and tighten securely.
- Bottom plunger firmly in plunger adapter against crosshead and tighten adapter securely.
- Install plastic elbow tubing connector (3000) into side of pump casing. Install tubing (3010) between relief valve fitting and plastic connector.
- Install pipe plug (340) in bottom of catchall.
- Proceed to start-up instructions in operations section.

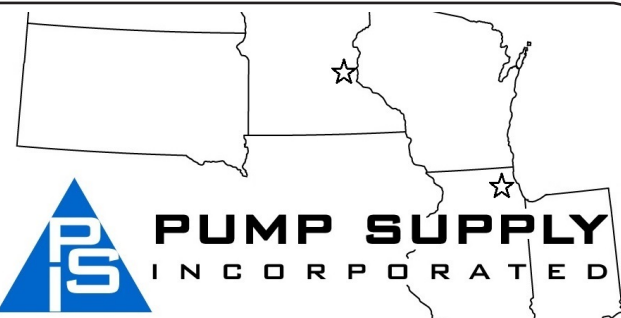
<p><b><u>Illinois Location:</u></b> (847) 841-7867 860 Church Rd Elgin, IL 60120</p> <p><b><u>Minnesota Location:</u></b> (651) 758-7867 330 Mill Bay South Suite 100 Afton, MN 55001</p> <p>PumpSupplyInc.com</p>	
--	--



## SECTION 3 - OPERATION

### 3.1 PUMP START-UP PROCEDURE

**▲ WARNING** FAILURE TO CHECK ALL METALLIC HEAD BOLTS PRIOR TO STARTUP AND AFTER ONE WEEK OF OPERATION MAY EXPOSE OPERATING PERSONNEL TO HAZARDOUS LIQUIDS.

**▲ CAUTION** DO NOT RUN THE MOTOR UNTIL ALL START UP STEPS HAVE BEEN COMPLETED. YOU COULD DAMAGE THE PUMP IF YOU RUN THE MOTOR BEFORE ALL OF THE STEPS HAVE BEEN COMPLETED. IT MAY BE NECESSARY TO TEST THE MOTOR OFF THE PUMP TO INSURE PROPER DIRECTION AND OPERATION. THE MOTOR DIRECTION IS CRITICAL. WIRE THE MOTOR SO THAT IT ROTATES IN THE DIRECTION OF THE ARROW CAST ON THE MOTOR MOUNT FLANGE. CONSULT MANUFACTURER DOCUMENTATION FOR MOTOR START UP RECOMMENDATIONS.

1. Recheck bolt tightness and re-tighten bolts (90/100 ft.-lbs.), if necessary.
2. Follow the motor mounting procedure before attempting to start your pumps. On some pumps, the motor is mounted at the factory.
3. Make the proper electrical connections to the motor per the manufacturer’s recommendations. Make sure the motor is properly grounded.
4. Make sure that all of the mounting holes for the pump base are used to securely tighten the base to the mounting area.
5. Do not run the motor until **ALL** start up steps have been completed.

GEAR LUBRICANT	QUANTITY
Zurn AGMA 7	2.5 Gal (9.5 Liter)
Food grade substitutes: Nevastane EP 460	

**Table 2. Gear Oil**

6. Remove the gear drive fill cap or cover/lid (the chamber closest to the motor).
7. Fill the gear drive chamber with appropriate gear lubricant (Table 2). This oil was shipped with the pump. Fill this chamber so that the oil level is even with the top oil level plug. Do not overfill (see pump drive instruction manual (53940), paragraph 2.3).

8. Remove the catchall cover or chamber vent cap (closest to the process liquid end of the pump) revealing the plunger. Fill this chamber with hydraulic oil, (Table 3). This oil was shipped with your pump, and is a lower viscosity compared to the gear oil. The hydraulic fluid must fill the catchall chamber so that the oil level is just above the plunger sleeve.

HYDRAULIC OIL	QUANTITY
Zurnpreen 15A	3 Qt (2.8 Liter)
Food grade substitute -Nevastane AW 32	

**Table 3. Hydraulic Oil**

**NOTE:**

*Two types of oils have been provided. They must be added at the proper location.*

9. Replace catchall cover.
10. Now fill the entire diaphragm displacement chamber in the liquid end with hydraulic oil, (Table 2).

**NOTE:**

*The following steps (11-16) are not necessary on new pumps rec'd from the factory. It is necessary anytime the head and diaphragm are removed (Section 4, maintenance).*

11. Disconnect outlet tube from relief valve (1040) and remove relief valve from liquid end. Make sure that the O-ring between displacement chamber and relief valve does not get lost or damaged, and that the opening in the displacement chamber is clean.
12. Make sure that the capacity adjustment (hand knob or automatic control) is set at 100%.
13. Rotate motor coupling until the piston and crosshead are in the full forward position (closest to pump liquid end).







## SECTION 3 - OPERATION

14. Fill the opening in the displacement chamber (630) through the port uncovered by removal of the relief valve in step 1 with the hydraulic oil furnished with the pump (Table 3). Fill the chamber slowly, allowing air bubbles to escape, until the oil level reaches the very top.

**CAUTION** IF THE DISPLACEMENT CHAMBER IS FILLED WITH THE PLUNGER FULLY REARWARD, THE DIAPHRAGM COULD RUPTURE AT START-UP. TO PROPERLY FILL THE DISPLACEMENT CHAMBER, THE PLUNGER MUST BE POSITIONED SO THAT IT IS FULLY FORWARD IN THE DISPLACEMENT CHAMBER.

15. With the plunger fully engaged in the displacement chamber (pump at TDC, Top Dead Center) adjust the stroke adjustment mechanism until the indicating needle reads 100%. Either turn the hand wheel on a micrometer, apply a 15-PSI supply signal for a Pneumatic, or apply a 20-mA signal for an Electronic actuator. In order to fill each displacement chamber, rotate the motor either by hand (by removing the fan cover and spinning the fan by hand), or by rotating the motor electrically. The motor may be jogged by turning the power on and off very quickly.

**CAUTION** IT IS VERY IMPORTANT NOT TO ROTATE THE MOTOR AT HIGH SPEED, BECAUSE HYDRAULIC FLUID WILL BE FORCED FROM THE AIR BLEED PORT AT A VERY HIGH VELOCITY.

16. On multiplex units, repeat these two steps for each pump to insure proper hydraulic fill in each displacement chamber.

17. Recheck the oil level in the catchall reservoir and install the cover, screws and lock washers.

**CAUTION** ALWAYS WEAR THE PROPER PROTECTIVE GEAR WHEN WORKING ON THE PUMP LIQUID END.

18. Connect suction and discharge piping manifolds. Use the proper gaskets and tighten each flange evenly. Check that all connections are tight including the check valves, flanges, and air relief valves.

19. It is advisable to test the pump for proper operation by testing it with water before you use a process fluid.

**WARNING** TAKE ADDITIONAL SAFETY MEASURES APPROPRIATE TO THE LIQUID BEING PUMPED. BE EXTREMELY CAREFUL IN THE PRESENCE OF HAZARDOUS SUBSTANCES (CORROSIVES, TOXINS, SOLVENTS, ACIDS, CAUSTICS, AND FLAMMABLES).

### NOTE:

*If so equipped, loosen each process bleeder barb on each pump to bleed any air from the liquid end. Connect a hose to this barb and use caution if you are pumping a hazardous chemical. After all process liquid ends have been purged of air, you can tighten all bleeder barbs to prevent leakage.*

20. Now the motor can be started if and only if all steps have been followed.

a). For constant speed motors, adjust the stroke adjustment mechanism so that the indication needle reads 25-30%. Gradually increase the capacity adjustment mechanism and increase backpressure to insure that the pump has time to purge all air from the system.



## SECTION 3 - OPERATION

- b). For a variable speed drive, the motor should be run at a very slow speed between 75-100 revolutions per minute, and the pump should have minimal process back pressure for initial start up. Gradually increase the motor speed and increase back-pressure to insure that the pump time to purge all air from the system.

**⚠ CAUTION** WHENEVER AN HPD PUMP IS SHUT DOWN (NOT PUMPING) THE DISCHARGE LINE MUST BE RELIEVED OF PRESSURE WHEN THAT PRESSURE IS ABOVE THE MAX SUCTION PRESSURE. FAILURE TO RELIEVE PRESSURE IN THE DISCHARGE LINE CAN DAMAGE THE CONTOUR PLATE.

**NOTE:**

*This concludes the start-up procedure. Please follow these steps to insure start-up success and reduce any risk of damage to the pump.*

### 3.2 RELIEF VALVE ADJUSTMENT

**⚠ WARNING** THE PRESSURE RELIEF VALVE (1040) IS FACTORY SET TO OPEN AT A PRESSURE SLIGHTLY ABOVE THE PUMP MAXIMUM OPERATING DISCHARGE PRESSURE; NEVER SET THE VALVE AT ANY GREATER PRESSURE.

All HPD liquid ends have a built in relief valve that allows hydraulic fluid to return to the hydraulic fluid reservoir if excessive pressure builds up in the discharge line. This effectively stops the pump from pumping, since the forward stroke of the piston will not displace the hydraulic fluid and force the diaphragm to flex. Please read "Principle of Operation" and see *Figures 1 and 2* for more information. This relief valve is to protect the pump and is not to be used in lieu of a system relief valve.

The HPD liquid end relief valve may be adjusted to operating conditions by the following procedure. Adjust the relief valve after first installing the pump and after any maintenance procedures.

1. A pressure gauge and shut off valve must be installed in the discharge line to complete this procedure. If the necessary equipment is not installed, *refer to the "Typical Piping" instructions in Section 2.*
2. Make sure suction and discharge lines are open. Start pump and pump process liquid to drain or other safe point to establish proper pumping action.
3. Set capacity control at 30%.

**⚠ WARNING** KEEP HANDS AWAY FROM RECIPROCATING PLUNGER AND CROSSHEAD.

**⚠ WARNING** DO NOT LEAVE PUMP OPERATING UNATTENDED WITH SHUT OFF VALVE CLOSED! EXCESSIVE PRESSURE CAN BUILD QUICKLY, POSSIBLY CAUSING SEVERE DAMAGE TO PUMP AND / OR PIPING. SINCE THE RELIEF VALVE IS NOT YET PROPERLY ADJUSTED, IT CAN NOT BE RELIED ON TO LIMIT EXCESSIVE PRESSURE BUILD-UP. BE SURE TO WATCH PRESSURE GAUGE VERY CAREFULLY AND OPEN SHUT OFF VALVE IMMEDIATELY IF EXCESSIVE PRESSURE DEVELOPS.

4. Close discharge line shut off valve slowly ("dead head" the pump) and closely watch the pressure increase on the pressure gauge. If pressure exceeds desired value, quickly open shut off valve to relieve pressure in line. Back off relief valve pressure and repeat until pressure is below desired setting when valve is closed.
5. With shut off valves still closed, adjust relief valve adjusting screw located on top of valve until maximum desired relief valve pressure reading is obtained on gauge.

## SECTION 3 - OPERATION

6. After setting relief valve, make sure discharge line shut off valve is fully open. Remove pressure gauge from line or leave in place, as desired, and place pump in routine service.

**⚠ WARNING** NEVER OPEN THIS VALVE DURING PRESSURIZED PUMP OPERATION.

7. The low-flow diaphragm head is equipped with a manual air bleed purge valve built in just below the discharge port. The purpose of this device is to vent entrapped air from the diaphragm head during priming and start-up. The end of this fitting will accept a 1/4" inside diameter flexible tubing in order to pipe off the solution to a non-hazardous location. Immediately after priming, the fitting should be tightened.

**Illinois Location:**  
(847) 841-7867  
860 Church Rd Elgin, IL 60120

**Minnesota Location:**  
(651) 758-7867  
330 Mill Bay South Suite  
Afton, MN 55001

PumpSupplyInc.com



**PUMP SUPPLY**  
INCORPORATED

## SECTION 4 - MAINTENANCE

### 4.1 RECOMMENDED SPARE PARTS

**Be Prepared.** To avoid delays in repairs, the following spare parts should be ordered for each pump:

Two Routine Preventive Maintenance Kits (RPM), which contains replacements for those parts which are subject to wear; specifically the ball checks, check valve seats, gaskets, and the hydraulic fluid strainer (See *RPM Kits below*). Liquid end with double balls requires **2 kits per check valve or 4 kits per pump.**

Plunger Diameter	Liquid End Material	Kit Part Number
7/16", 9/16", 5/8"	316SS	RPM-0011-011
	Alloy 20	RPM-0011-015

**Table 4. Milroyal® B Low Flow RPM Kits**

Replacing these parts annually will reduce the possibility of unexpected failure. Regular maintenance will help to extend pump life.

Parts orders must include the following:

1. Serial number (found on nameplate)
2. Model number (found on nameplate)
3. Quantity required
4. Part number
5. Part description

Always include the serial and model numbers in all correspondence regarding the unit. **RPM Kits do not contain diaphragms.** See *diaphragm replacement later in section 4.*



### 4.2 RETURNING UNITS TO THE FACTORY

Pumps will not be accepted for repair without a Return Material Authorization, available from the factory or other authorized Customer Service Department. Pumps returned to the factory for repairs should be clearly labeled to indicate the liquid being pumped. The pump must be decontaminated internally and externally by flushing all process liquids, and all internal lubricants before the pump is shipped.

**NOTE:**

*Federal law prohibits handling of equipment that is not accompanied by an OSHA Safety Data Sheet (SDS). A completed SDS must be packed in the shipping crate with any pump returned to the factory. These safety precautions will aid the troubleshooting and repair procedure and protect our personnel from liquid end. A Safety Data Sheet is available on our website.*

could be addressed by a representative. See the link on our website.

### 4.3 ROUTINE PREVENTIVE MAINTENANCE

**⚠ WARNING** BEFORE ANY MAINTENANCE, RELIEVE ALL PRESSURE FROM SYSTEM, ISOLATE LIQUID END FROM ALL SOURCES OF PROCESS LIQUID WITH APPROPRIATE VALVING, AND PURGE LIQUID END OF ALL PROCESS LIQUID.

### 4.4 MARS REFILL VALVE (640)

The MARS refill valve (640) requires no periodic maintenance. Clean hydraulic oil is critical for proper operation. These valves can be removed from the displacement chamber using a wrench on the hex. Do not attempt removal by prying.

Always replace the O-ring (390) when installing the valve. Lubricate the O-ring and displacement chamber liberally with oil. Screw the valve back into the chamber. If the valve is damaged or broken, replace the entire assembly.

## SECTION 4 - MAINTENANCE

### 4.5 HYDRAULIC OIL REPLACEMENT

Inspect and replace hydraulic oil on the same schedule as the pump's gear drive lubricant (or whenever diaphragm is replaced). Annual replacement is recommended. While replacing the hydraulic oil, it is also recommended that the hydraulic oil strainer be replaced. The strainer, (990) which screws into the displacement chamber can become fouled or clogged over time.

**▲ WARNING** BEFORE ANY MAINTENANCE, RELIEVE ALL PRESSURE FROM SYSTEM, ISOLATE LIQUID END FROM ALL SOURCES OF PROCESS LIQUID WITH APPROPRIATE VALVING, AND PURGE LIQUID END OF ALL PROCESS LIQUID.

To replace the hydraulic oil:

1. Remove the catchall cover by unscrewing the four screws, which hold it on.
2. Place a container under the pump catchall to catch the oil and unscrew the catchall drain plug.
3. When oil has finished draining, make sure that the area around the drain hole is clean. Screw drain plug back in securely.
4. Fill the catchall to the top of the oil seal that surrounds the crosshead with new, clean oil. Use hydraulic oil or any good quality type A automobile transmission fluid.
5. Replace the catchall cover and screw firmly in place.

**NOTE:**

*It is not necessary to purge the liquid end displacement chamber of oil during annual oil replacement.*

6. Dispose of oil according to federal, state, or local codes that may apply.

### 4.6 CHECK VALVE MAINTENANCE

#### 4.6.1 Cleaning Fouled Check Valves

Check valve assemblies are designed to be selfcleaning and should seldom need servicing. Fouled check valves can usually be cleaned by pumping a solution of mild detergent and warm water (if compatible with liquid being pumped) for 15 minutes, followed by flushing with water.

#### 4.6.2 Check Valve Replacement (General)

Milton Roy recommends at minimum an annual tune up using a RPM kit. The user may need to increase or decrease this frequency defined by their own specific operating conditions. RPM kits contain replacements for parts which are subject to wear; specifically ball checks, check valve seats, gaskets, and strainer. Replacing these parts annually, or defined by the user, with an RPM kit can reduce the possibility of unexpected downtime and will help to extend pump life.

#### 4.6.3 Disassembly

**▲ WARNING** BEFORE PERFORMING ANY MAINTENANCE ON THE CHECK VALVES, RELIEVE ALL PRESSURE FROM SYSTEM, ISOLATE LIQUID END FROM ALL SOURCES OF PROCESS LIQUID WITH APPROPRIATE VALVING, AND PURGE LIQUID END OF ALL PROCESS FLUID.

After insuring that all system pressure has been relieved and that all hazardous process liquids have been flushed from the liquid end, disconnect both the suction inlet and discharge outlet from the system piping.

1. Loosen the four retaining nuts (830) evenly, then remove. A slight force applied to the port connector (820) will provide sufficient clearance to lift and slide out the ball guide (790), seat, ball and gaskets (*see the exploded drawing in the RPM Kit brochure RPM 11.1*). Once disassembled, the PTFE gaskets should be discarded.





## SECTION 4 - MAINTENANCE

2. Inspect the balls carefully. If they are smooth, round and free of deposits or pits, then they are suitable for continued use. Examine the check valve seats. The area of the seat where it meets the ball (the un-chamfered side) must be in near perfect condition for continued use. Any imperfection visible on the seating surface (pits, erosion, cracks, or a ball shaped contour greater than 0.030 deep) makes the seat unusable. If both the balls and seats are in good condition, then the length of time between parts replacement may be lengthened. If the balls and seats are severely damaged, then the length of time between parts replacement should be shortened.
3. The PTFE gaskets that fit between all mating components of the check valve stack, are held in place with sealing grooves. Inspect these grooves with a magnifying glass. If the grooves are deformed, dented, or damaged in any manner, the damaged part should be replaced to prevent leakage. Clean these grooves with a small, stiff bristle brush prior to reassembly. Note that the port connections and ball cages are not included with the RPM kit. If these parts are damaged, they must be ordered separately.
4. All PTFE gaskets should be replaced anytime check valves are disassembled.

### 4.6.4 Reassembly

1. Replace the components in the orientation shown in the RPM kit exploded drawing, using the new parts included in the kit. Install an unused gasket between each set of thoroughly cleaned components. Tighten the stud nuts evenly by hand only, then rotate the components to insure that they are properly guided and mated. Snug up on the nuts evenly to prevent cocking of the assembly and subsequent leakage of process liquid to surroundings.

### 4.7 DIAPHRAGM REPLACEMENT

The low-flow HPD diaphragm is extremely durable and often lasts for many years of service. As a preventive measure however, Milton Roy recommends that the diaphragm be replaced yearly to coincide with the annual check valve replacement (*see table below*).

The following is the diaphragm replacement procedure:

Plunger Diameter	Liquid End Material	Kit Part Number
7/16", 9/16", 5/8"	316SS, Alloy 20	20325

**Table 5. Milroyal® B Low-Flow Diaphragm P/N**

The diaphragm can be replaced by removing the diaphragm head only or by removing the complete liquid end and placing it on a sturdy work bench.

When the liquid end is equipped with leak detection the complete liquid end should be removed and placed on a sturdy work bench.

#### 4.7.1 Removing Liquid End

**▲ WARNING** STOP PUMP AND RELIEVE ALL PRESSURE FROM SYSTEM. ISOLATE THE LIQUID END FROM ALL SOURCES OF PROCESS LIQUID WITH APPROPRIATE VALVING AND PURGE LIQUID END OF ALL PROCESS FLUID.

1. Disconnect both suction inlet and discharge outlet from piping system.

#### NOTE:

*Approximately one pint of oil will still be present in the contour plate area which will be released when the diaphragm is removed. Prepare your work area accordingly.*

2. Remove catchall cover and drain catchall of hydraulic oil by removing pipe plug (340) at bottom of casing.
3. Completely loosen adapter plunger (2020) located inside catchall.



## SECTION 4 - MAINTENANCE

4. Disconnect all tubing that connects liquid end to pump body.

**NOTE:**

*The liquid end can be heavy (50 lbs. or more). A hoist may be required to move it.*

**NOTE:**

*It is often easier to break head bolts (710) loose, prior to removing assembly from drive unit (see removing the diaphragm step 1).*

5. Support liquid end with a hoist and remove liquid end head bolts that hold the displacement chamber (2050) to the pump body. Pull liquid end and plunger off, being careful to protect the plunger from damage. Carefully raise liquid end and plunger over catchall and pull plunger from liquid end, allowing hydraulic fluid to drain back into catchall. Pull plunger firmly but carefully, being careful not to bend or otherwise damage the plunger.
6. Place liquid end, diaphragm head up, on a bench or other clean, flat, and convenient working area.

### 4.7.2 Removing Diaphragm

1. Remove diaphragm head bolts (710) that hold diaphragm head (700) to displacement chamber (630). Remove diaphragm head. Diaphragm (670) may pull off with diaphragm head or remain with displacement chamber.
2. Remove diaphragm (670) (When equipped with leak detection remove two diaphragms, leak detection ring A (8081), leak detection ring B (8080), and leak detection ring spacer (8082). Leak detection ring A, leak detection ring B and leak detection ring spacer can be reused) and clean all sealing surfaces.

### 4.7.3 Replacing Diaphragm

1. Prior to replacing diaphragm, make sure contour plate assembly (650) is installed so orientation pin on back of contour plate fits into mating hold in displacement chamber (630). The contour plate should rest flat against displacement chamber and does not rock.
2. Place diaphragm so that its shape conforms to contour plate. Replace containment "O" ring (635), if so equipped. (When equipped with leak detection install two diaphragms, leak detection ring A (8081), leak detection ring B (8080) and leak detection ring spacer (8082) removed previously. Apply a small amount of mineral oil between the diaphragms. Stacked diaphragms and rings may be aligned using the three small holes/pins as a guide)

**NOTE:**

*Apply anti-seize thread lubricant to the bolts.*

3. Reinstall diaphragm head (700) on displacement chamber (630) making sure direction arrows on check valve bodies are pointing up. Your pump may have three guide pins inserted in the displacement chamber. When guide pins are installed they can be used to help hold diaphragm (670) in place while diaphragm head (700) is bolted to displacement chamber (630).
4. Lubricate diaphragm head bolts with pump gear oil or equivalent prior to reassembly. Install the diaphragm head bolts and torque bolts in a crisscross sequence to 50 ft.-lb. Repeat crisscross sequence torquing bolts to a final torque value of 90-100 ft.-lb.

Plunger Diameter	Pressure	Torque (ft-lbs)
7/16", 9/16", 5/8"	All	90/100

**Table 6. Head Bolt Torque Values**





---

## SECTION 4 - MAINTENANCE

---

### 4.7.4 Reinstalling Liquid End

1. Reconnect the liquid end to the pump by reversing instructional steps 1 through 6 under "Removing Liquid End".
2. Fill the liquid end with hydraulic oil (*refer to above "INITIAL START-UP" procedure, Section 3*). If working on a double diaphragm (leak detection) pump, be sure to also fill the intermediate chamber as well.

### 4.8 CORRECTIVE MAINTENANCE

#### 4.8.1 Relief Valve Assembly

The relief valve assembly (1040) operates in filtered hydraulic oil and should require maintenance only if unusual circumstances occur, such as if corrosive media contaminates the fluid. Assembly and disassembly is straightforward. Field servicing should be limited to inspection and cleaning only. Repairs of this critical component should only be carried out by an authorized Milton Roy repair facility.

<p><b><u>Illinois Location:</u></b> (847) 841-7867 860 Church Rd Elgin, IL 60120</p> <p><b><u>Minnesota Location:</u></b> (651) 758-7867 330 Mill Bay South Suite Afton, MN 55001</p> <p>PumpSupplyInc.com</p>	 <p><b>PS</b> <b>PUMP SUPPLY</b> INCORPORATED</p>
--	--

## SECTION 5 - TROUBLESHOOTING

Pump drive instruction manuals list most possible malfunctions, their causes and remedies. The following problems are peculiar to Low-Flow HPD liquid ends and may be repaired as indicated below. Refer to the drive manual listed in *Sections 1* for additional troubleshooting procedures.

SYMPTOMS	REMEDIES
Excessive delivery	<ul style="list-style-type: none"> <li>• Low discharge line pressure. Increase line pressure. (e.g,install a back pressure valve.)</li> </ul>
Insufficient delivery	<ul style="list-style-type: none"> <li>• Relief valve relieving.                             <ul style="list-style-type: none"> <li>-Blocked discharge line. Clear line.</li> <li>-Relief valve set too low. Adjust valve to operating conditions.</li> </ul> </li> <li>• Air in hydraulic system. Fill displacement chamber with hydraulic oil to proper level.</li> <li>• Clogged refill line. Remove strainer assembly and clean or replace.</li> </ul>
Erratic delivery	<ul style="list-style-type: none"> <li>• Leaky relief valve. Repair or replace valve.</li> <li>• Blocked suction line. Clean line, particularly the line strainer.</li> <li>• Insufficient NPSH. Most common with long suction lines, small diameter suction lines, acid pumping, polymer (viscous) liquids, or drawing from a source lower than the pump. Consult your local representative or the Milton Roy factory.</li> </ul>

**Illinois Location:**  
(847) 841-7867  
860 Church Rd Elgin, IL 60120

**Minnesota Location:**  
(651) 758-7867  
330 Mill Bay South Suite  
Afton, MN 55001

PumpSupplyInc.com





**PUMP SUPPLY**  
INCORPORATED

## SECTION 6 - PARTS

### 6.1 GENERAL

This section gives information regarding replaceable components for the Low-Flow HPD liquid ends. When ordering parts, please refer to the parts ordering instructions listed under "Recommended Spare Parts" in the Maintenance Section (*Section 4*). Be sure to include all required information with your parts order, or Milton Roy may be unable to process your order.

#### NOTE:

*All drawings in this manual represent standard configured pumps. Notify Milton Roy for all special configured pumps (See Paragraph 1.4 Model Coding).*

### 6.2 ILLUSTRATED PARTS LIST

#### 1. Figure and Item Number Column

- a) The item numbers shown in the detailed parts list correspond to the item numbers appearing on the exploded view illustration. To find an unknown part number, locate the part on the illustration and note the item number. Look for the item number on the detailed parts list. The part number is on the same line. A dash (-) precedes non-illustrated item numbers.

#### 2. Description Column

- a) The name of the item is in the description column.

#### 3. Part Number Column

- a) The supplier's part number is listed in the part number column.

#### 4. Quantity Column

- a) The numbers appearing in the quantity column are the total quantity of the listed part required in its immediate assembly.

#### 5. Reference Code Column

- a) This column is used to denote assembly and detail part variations among similar components (models) covered by this publication. When the symbol "A", "B", "C", etc. is entered in this column, the part is used only in the model liquid end and material codes, see Data Sheets (*Referenced Section 1*) and pump data plate at which the symbol appears. If the column is blank, the part is used in all models.

**Illinois Location:**  
(847) 841-7867  
860 Church Rd Elgin, IL 60120

**Minnesota Location:**  
(651) 758-7867  
330 Mill Bay South Suite 100  
Afton, MN 55001

PumpSupplyInc.com





**PUMP SUPPLY**  
INCORPORATED

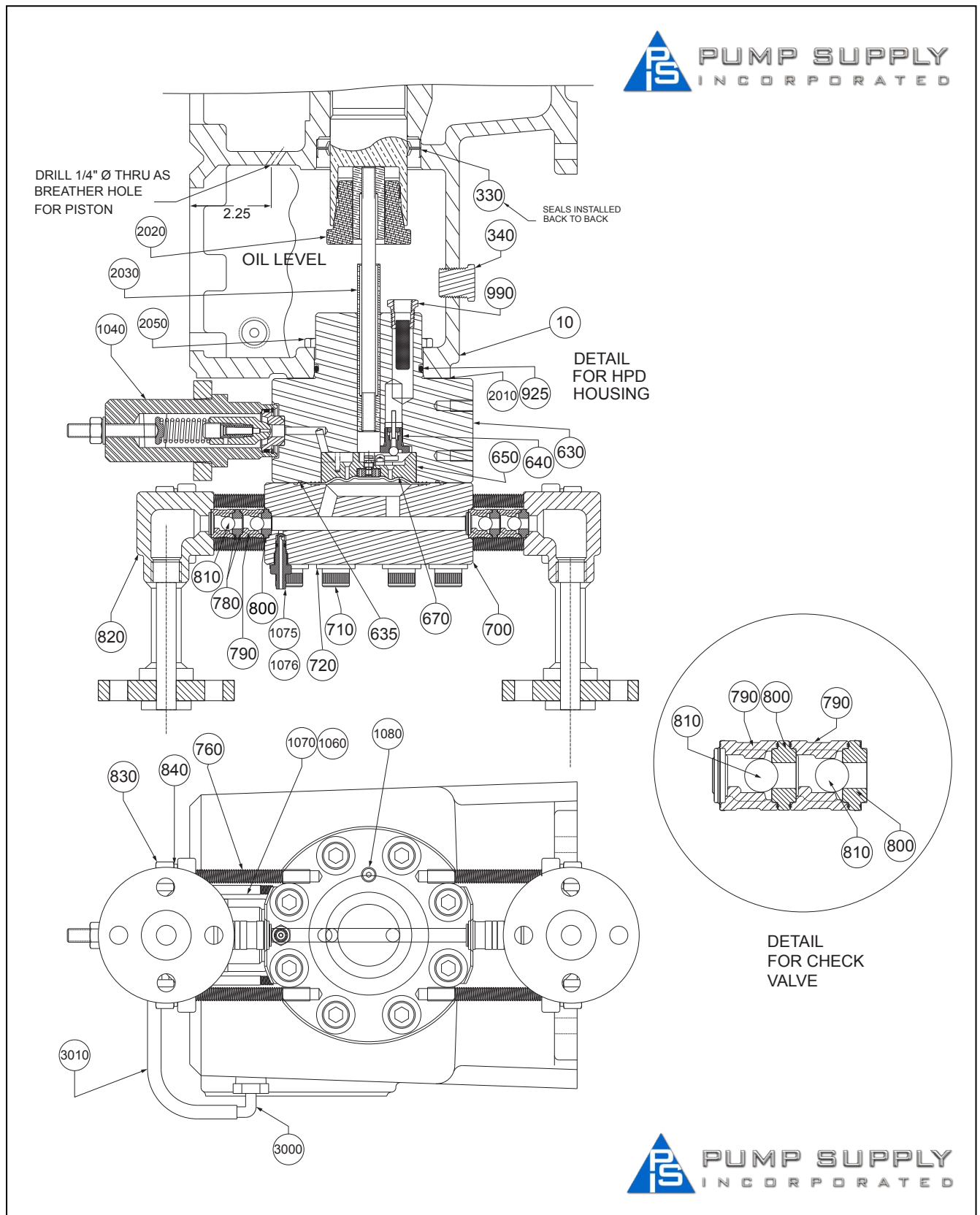

**Figure 4. Milroyal® B HPD Low Flow Liquid End Assembly  
(102-2095-000 Sheet 10) (Sheet 1 of 2).**

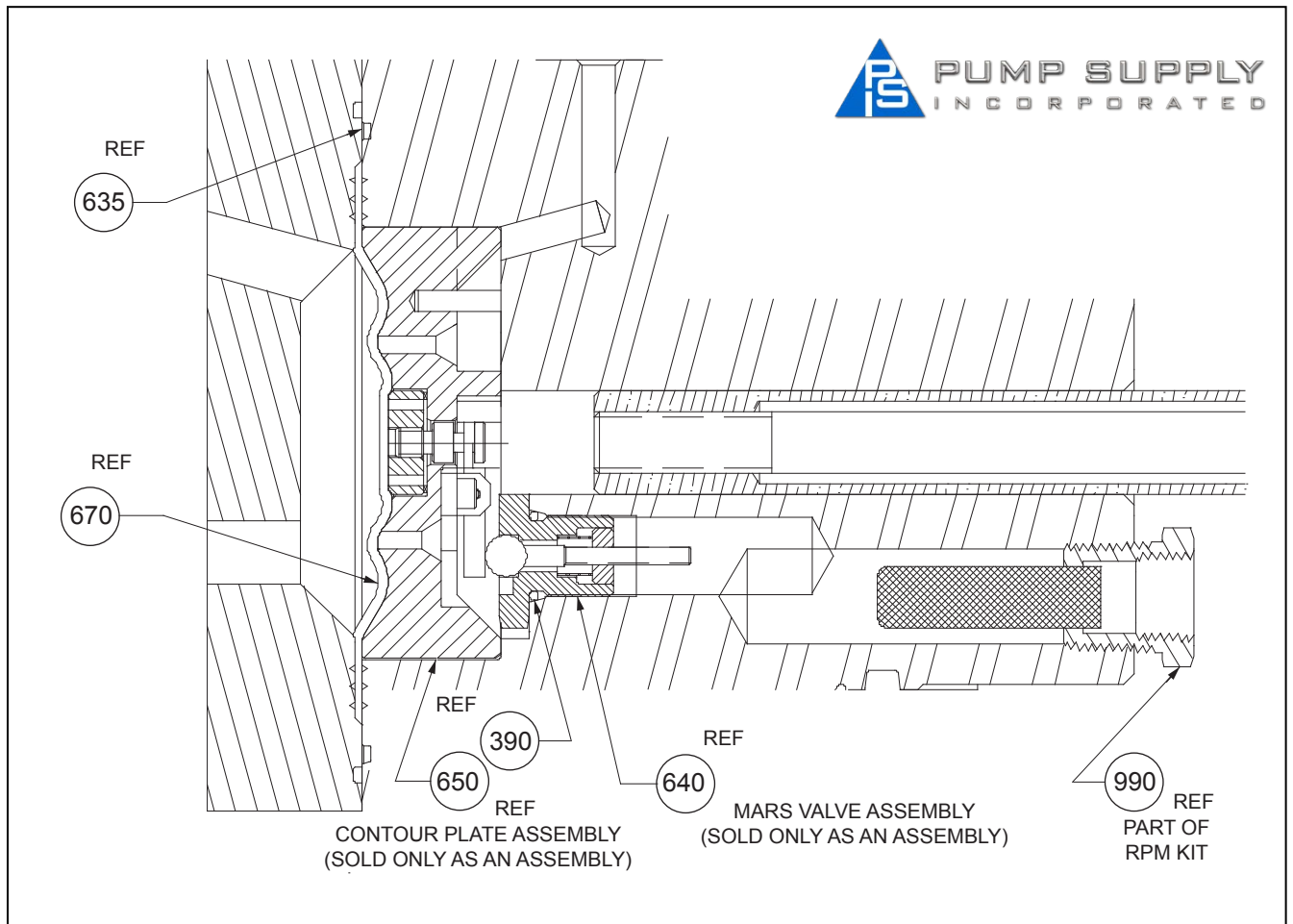

**Figure 4. Milroyal® B HPD Low Flow Liquid End Assembly  
(102-2095-000 Sheet 10) (Sheet 1 of 2).**

**Illinois Location:**  
(847) 841-7867  
860 Church Rd Elgin, IL 60120

**Minnesota Location:**  
(651) 758-7867  
330 Mill Bay South Suite :  
Afton, MN 55001

PumpSupplyInc.com

**PS** PUMP SUPPLY  
INCORPORATED

### 6.3 PARTS LIST FOR LOW-FLOW LIQUID END, 7/16 PLUNGER

**Model:**

<b>Liquid End:</b>	<b>Material:</b>	<b>Reference Code:</b>
07	1	A (316SS)
07	5	B (ALLOY 20)
07	6	C (ALLOY C22, CALL MILTON ROY)



<b>FIGURE NUMBER</b>	<b>ITEM NUMBER</b>	<b>DESCRIPTION</b>	<b>PART NUMBER</b>	<b>QTY</b>	<b>REFERENCE CODE</b>
3	10	Housing, Main MIL B, Steel	2810047001	1	
	170	O-Ring, 2-114 Viton	4080068045	1	
	330	Oil Seal - Crosshead	4080031020	2	
	340	Square Head Pipe, 150#, 304SS	4020009024	1	
	390	O-ring, Parker 3-905 Buna N	4089998052	1	
	630	Displacement Chamber 7/16" HPD, Steel	20317	1	
	635	O-ring, 2-044 Viton 70 Duro	4080109415	1	
	640	Mars Assembly	10001	1	
	650	Contour Plate Assy	30616	1	
	670	Diaphragm, Lo-Flow HPD	20325	1	
	700	Head, Diaphragm, 316SS	20319	1	A
	700	Head, Diaphragm, CA 20	20527	1	B
	710	Screw, Soc Head, 1/2" - 13" x 3-1/4"	4050031214	8	
	720	Washer, Flat, 1/2", Steel	4040151033	8	
	760	Stud, 3/8" - 16"UNC X 4-1/2", 300SS	4050160143	8	
	780	Gasket, Teflon, 3/8" Ball, 316SS	2250075075	10	
	780	Gasket, Teflon, 3/8" Ball, Drag Reducer CV	2250075175	6	A
	-	Check Valve Port Adapter, Drag Reducer CV	22264	4	A
	790	Guide, 3/8" Ball, 316SS	2920054016	4	A
	790	Guide, 3/8" Ball, CA 20	2920054029	4	B
	790	Guide, 5/8" Ball, Drag Reducer CV	61086	2	A
	800	Seat, 3/8" Ball, 316SS	2240099016	4	A
	800	Seat, 3/8" Ball, CA 20	2240099028	4	B
	800	Seat, 5/8" Ball, 316SS, Drag Reducer CV	60863	2	A
810	Ball, 3/8" Ball, 316SS Grade 50	4070014112	4	A	

- Items Not Shown

\* Double Quantity for Double Checks



FIGURE NUMBER	ITEM NUMBER	DESCRIPTION	PART NUMBER	QTY	REFERENCE CODE
3	810	Ball, 3/8" Ball, CA 20 Grade 50	4070014113	4	B
	810	Ball, 5/8" Ball, 316SS, Drag Reducer CV	4070014172	2	A
	820	Flange, Port Adapter, NPT, 316SS	2710044216	2	A
	820	Flange, Port Adapter, NPT, CA 20	2710044229	2	B
	820	Flange, Port Adapter, 150# RAISED FACE SOCKET WELD, 1/2" 316SS	2710060000	2	A
	820	Flange, Port Adapter, 300# RAISED FACE SOCKET WELD, 1/2" 316SS	1791579016	2	A
	820	Flange, Port Adapter, 600# RAISED FACE SOCKET WELD, 1/2" 316SS	2710060000	2	A
	820	Flange, Port Adapter, 1500# RAISED FACE SOCKET WELD, 1/2" 316SS	20606	2	A
	820	Flange, Port Adapter, 150# RAISED FACE SOCKET WELD, 1/2" CA 20	20119	2	B
	820	Flange, Port Adapter, 300# RAISED FACE SOCKET WELD, 1/2" CA 20	20120	2	B
	820	Flange, Port Adapter, 600# RAISED FACE SOCKET WELD, 1/2" CA 20	20121	2	B
	820	Flange, Port Adapter, RAISED FACE THREADED, 1/2" 316SS	2710044216	2	A
	-	Nipple, THREADED, 1/2 x 3 SCH40, 316SS, Use with 150 & 300# Flange	4020052053	2	A
	-	Flange, 150# RAISED FACE THREADED, 1/2" 316SS	4020013013	2	A
	-	Flange, 300# RAISED FACE THREADED, 1/2" 316SS	4020014013	2	A
	-	Flange, 600# RAISED FACE THREADED, 1/2" 316SS	4020015013	2	A
	-	Nipple, THREADED, 1/2 x 3 SCH80, 316SS, Use with 600# Flange	4020052223	2	A
	820	Flange, Port Adapter, RAISED FACE THREADED, 1/2" CA 20	2710044229	2	B



- Items Not Shown

\* Double Quantity for Double Checks





FIGURE NUMBER	ITEM NUMBER	DESCRIPTION	PART NUMBER	QTY	REFERENCE CODE
3	-	Nipple, THREADED, 1/2 x 3 SCH40, CA 20, Use with 150 & 300# Flange	4020052058	2	B
	-	Flange, 150# RAISED FACE THREADED, 1/2" CA 20	4020013017	2	B
	-	Flange, 300# RAISED FACE THREADED, 1/2" CA 20	4020014017	2	B
	-	Flange, 600# RAISED FACE THREADED, 1/2" CA 20	4020015017	2	B
	-	Nipple, THREADED, 1/2 x 3 SCH80, CA 20, Use with 600# Flange	4020052228	2	B
	830	Nut, Hex, 2/8" - 16NC, 18.8SS	4050066012	8	
	840	Washer, Spring Lock, 3/8" 18.8SS	4040041022	8	
	925	O-ring, Nitrile 70 Duro, 2-232	4080095231	1	
	990	Fitting, Strainer HPD	2450021000	1	
	1040	Valve Assy (Advise Serial & Model Number)	1010021X06	1	
	1060	Lock Washer, Spring, 5/16"	4040040028	2	
	1070	Screw, Socket Head, 5/16"-18"x2-3/4"	4050028194	2	
	1075	Barb, Air Bleed, 316SS	20352	1	A
	1075	Barb, Air Bleed, CA 20	20528	1	B
	1076	O-ring, 2-007, Viton	4080109045	1	
	1080	Plug, Pipe, 1/8 Hex HD, #6000	4020012013	1	
	2010	Gasket	2250035199	1	
	2020	Adapter, Plunger, 7/8" Hole	2720026406	1	
	2030	Plunger, Assy, 7/16" Low-Flow	20321	1	
	2050	Screw, Hex Head, 3/8"-16"x1-1/4"	4050018136	4	
3000	Tubing, Barb, 1/2", NPT x 1/2"	4020503187	1		
3010	Tubing, 1/2"	4020296091	1		

- Items Not Shown

\* Double Quantity for Double Checks

**Illinois Location:**  
(847) 841-7867  
860 Church Rd Elgin, IL 61

**Minnesota Location:**  
(651) 758-7867  
330 Mill Bay South Suite  
Afton, MN 55001

PumpSupplyInc.com



**PS** **PUMP SUPPLY**  
INCORPORATED

### 6.4 PARTS LIST FOR LOW-FLOW LIQUID END, 9/16 PLUNGER

**Model:**

<u>Liquid End:</u>	<u>Material:</u>	<u>Reference Code:</u>
09	1	D (316SS)
09	5	E (ALLOY 20)
09	6	F (ALLOY C22, CALL MILTON ROY)



FIGURE NUMBER	ITEM NUMBER	DESCRIPTION	PART NUMBER	QTY	REFERENCE CODE
3	10	Housing, Main MIL B, Steel	2810047001	1	
	170	O-Ring, 2-114 Viton	4080068045	1	
	330	Oil Seal - Crosshead	4080031020	2	
	340	Square Head Pipe, 150#, 304SS	4020009024	1	
	390	O-ring, Parker 3-905 Buna N	4089998052	1	
	630	Displacement Chamber 9/16" HPD, Steel	20391	1	
	635	O-ring, 2-044 Viton 70 Duro	4080109415	1	
	640	Mars Assembly	10001	1	
	650	Contour Plt Assy	30616	1	
	670	Diaphragm, Lo-Flow HPD	20325	1	
	700	Head, Diaphragm, 316SS	20319	1	D
	700	Head, Diaphragm, CA 20	20527	1	E
	710	Screw, Soc Head, 1/2" - 13" x 3-1/4"	4050031214	8	
	720	Washer, Flat, 1/2", Steel	4040151033	8	
	760	Stud, 3/8" - 16"UNC X 4-1/2", 300SS	4050160143	8	
	780	Gasket, Teflon, 3/8" Ball, 316SS	2250075075	10	
	780	Gasket, Teflon, 3/8" Ball, Drag Reducer CV	2250075175	6	D
	-	Check Valve Port Adapter, Drag Reducer CV	22264	4	D
	790	Guide, 3/8" Ball, 316SS	2920054016	4	D
	790	Guide, 3/8" Ball, CA 20	2920054029	4	E
	790	Guide, 5/8" Ball, Drag Reducer CV	61086	2	D
	800	Seat, 3/8" Ball, 316SS	2240099016	4	D
	800	Seat, 3/8" Ball, CA 20	2240099028	4	E
800	Seat, 5/8" Ball, 316SS, Drag Reducer CV	60863	2	D	

- Items Not Shown

\* Double Quantity for Double Checks



FIGURE NUMBER	ITEM NUMBER	DESCRIPTION	PART NUMBER	QTY	REFERENCE CODE
3	810	Ball, 3/8" Ball, 316SS Grade 50	4070014112	4	D
	810	Ball, 3/8" Ball, CA 20 Grade 50	4070014113	4	E
	810	Ball, 5/8" Ball, 316SS, Drag Reducer CV	4070014172	2	D
	820	Flange, Port Adapter, NPT, 316SS	2710044216	2	D
	820	Flange, Port Adapter, NPT, CA 20	2710044229	2	E
	820	Flange, Port Adapter, 150# RAISED FACE SOCKET WELD, 1/2" 316SS	2710059000	2	D
	820	Flange, Port Adapter, 300# RAISED FACE SOCKET WELD, 1/2" 316SS	1791579016	2	D
	820	Flange, Port Adapter, 600# RAISED FACE SOCKET WELD, 1/2" 316SS	2710060000	2	D
	820	Flange, Port Adapter, 1500# RAISED FACE SOCKET WELD, 1/2" 316SS	20606	2	D
	820	Flange, Port Adapter, 150# RAISED FACE SOCKET WELD, 1/2" CA 20	20119	2	E
	820	Flange, Port Adapter, 300# RAISED FACE SOCKET WELD, 1/2" CA 20	20120	2	E
	820	Flange, Port Adapter, 600# RAISED FACE SOCKET WELD, 1/2" CA 20	20121	2	E
	820	Flange, Port Adapter, RAISED FACE THREADED, 1/2" 316SS	2710044216	2	D
	-	Nipple, THREADED, 1/2 x 3 SCH40, 316SS, Use with 150 & 300# Flange	4020052053	2	D
	-	Flange, 150# RAISED FACE THREADED, 1/2" 316SS	4020013013	2	D
	-	Flange, 300# RAISED FACE THREADED, 1/2" 316SS	4020014013	2	D
	-	Flange, 600# RAISED FACE THREADED, 1/2" 316SS	4020015013	2	D
	-	Nipple, THREADED, 1/2 x 3 SCH80, 316SS, Use with 600# Flange	4020052223	2	D
	820	Flange, Port Adapter, RAISED FACE THREADED, 1/2" CA 20	2710044229	2	E

- Items Not Shown

\* Double Quantity for Double Checks



FIGURE NUMBER	ITEM NUMBER	DESCRIPTION	PART NUMBER	QTY	REFERENCE CODE
3	-	Nipple, THREADED, 1/2 x 3 SCH40, CA 20, Use with 150 & 300# Flange	4020052058	2	E
	-	Flange, 150# RAISED FACE THREADED, 1/2" CA 20	4020013017	2	E
	-	Flange, 300# RAISED FACE THREADED, 1/2" CA 20	4020014017	2	E
	-	Flange, 600# RAISED FACE THREADED, 1/2" CA 20	4020015017	2	E
	-	Nipple, THREADED, 1/2 x 3 SCH80, CA 20, Use with 600# Flange	4020052228	2	E
	830	Nut, Hex, 2/8" - 16NC, 18.8SS	4050066012	8	
	840	Washer, Spring Lock, 3/8" 18.8SS	4040041022	8	
	925	O-ring, Nitrile 70 Duro, 2-232	4080095231	1	
	990	Fitting, Strainer HPD	2450021000	1	
	1040	Valve Assy (Advise Serial & Model Number)	1010021X06	1	
	1060	Lock Washer, Spring, 5/16"	4040040028	2	
	1070	Screw, Socket Head, 5/16"-18"x2-3/4"	4050028194	2	
	1075	Barb, Air Bleed, 316SS	20352	1	D
	1075	Barb, Air Bleed, CA 20	20528	1	E
	1076	O-ring, 2-007, Viton	4080109045	1	
	1080	Plug, Pipe, 1/8 Hex HD, #6000	4020012013	1	
	2010	Gasket	2250035199	1	
	2020	Adapter, Plunger, 7/8" Hole	2720026406	1	
	2030	Plunger, Assy, 9/16" Low-Flow	20390	1	
	2050	Screw, Hex Head, 3/8"-16"x1-1/4"	4050018136	4	
3000	Tubing, Barb, 1/2", NPT x 1/2"	4020503091	1		
3010	Tubing, 1/2"	4020296091	1		

- Items Not Shown

\* Double Quantity for Double Checks

**Illinois Location:**  
 (847) 841-7867  
 860 Church Rd Elgin, IL 60120

**Minnesota Location:**  
 (651) 758-7867  
 330 Mill Bay South Suite :  
 Afton, MN 55001

PumpSupplyInc.com



**PS** **PUMP SUPPLY**  
INCORPORATED

**6.5 PARTS LIST FOR LOW-FLOW LIQUID END, 5/8 PLUNGER****Model:**

<b>Liquid End:</b>	<b>Material:</b>	<b>Reference Code:</b>
10	1	G (316SS)
10	5	H (ALLOY 20)
10	6	I (ALLOY C22, CALL MILTON ROY)



<b>FIGURE NUMBER</b>	<b>ITEM NUMBER</b>	<b>DESCRIPTION</b>	<b>PART NUMBER</b>	<b>QTY</b>	<b>REFERENCE CODE</b>
3	10	Housing, Main MIL B, Steel	2810047001	1	
	170	O-Ring, 2-114 Viton	4080068045	1	
	330	Oil Seal - Crosshead	4080031020	2	
	340	Square Head Pipe, 150#, 304SS	4020009024	1	
	390	O-ring, Parker 3-905 Buna N	4089998052	1	
	630	Displacement Chamber 5/8" HPD, Steel	20318	1	
	635	O-ring, 2-044 Viton 70 Duro	4080109415	1	
	640	Mars Assembly	10001	1	
	650	Contour Plt Assy	30616	1	
	670	Diaphragm, Lo-Flow HPD	20325	1	
	700	Head, Diaphragm, 316SS	20319	1	G
	700	Head, Diaphragm, CA 20	20527	1	H
	710	Screw, Soc Head, 1/2" - 13" x 3-1/4"	4050031214	8	
	720	Washer, Flat, 1/2", Steel	4040151033	8	
	760	Stud, 3/8" - 16" UNC X 4-1/2", 300SS	4050160143	8	
	780	Gasket, Teflon, 3/8" Ball, 316SS	2250075075	10	
	780	Gasket, Teflon, 3/8" Ball, Drag Reducer CV	2250075175	6	G
	-	Check Valve Port Adapter, Drag Reducer CV	22264	4	G
	790	Guide, 3/8" Ball, 316SS	2920054016	4	G
	790	Guide, 3/8" Ball, CA 20	2920054029	4	H
	790	Guide, 5/8" Ball, Drag Reducer CV	61086	2	G
	800	Seat, 3/8" Ball, 316SS	2240099016	4	G
	800	Seat, 3/8" Ball, CA 20	2240099028	4	H
	800	Seat, 5/8" Ball, 316SS, Drag Reducer CV	60863	2	G
810	Ball, 3/8" Ball, 316SS Grade 50	4070014112	4	G	
810	Ball, 3/8" Ball, CA 20 Grade 50	4070014113	4	H	

- Items Not Shown

\* Double Quantity for Double Checks

FIGURE NUMBER	ITEM NUMBER	DESCRIPTION	PART NUMBER	QTY	REFERENCE CODE
3	810	Ball, 5/8" Ball, 316SS, Drag Reducer CV	4070014172	2	G
	820	Flange, Port Adapter, NPT, 316SS	2710044216	2	G
	820	Flange, Port Adapter, NPT, CA 20	2710044229	2	H
	820	Flange, Port Adapter, 150# RAISED FACE SOCKET WELD, 1/2" 316SS	2710059000	2	G
	820	Flange, Port Adapter, 300# RAISED FACE SOCKET WELD, 1/2" 316SS	1791579016	2	G
	820	Flange, Port Adapter, 600# RAISED FACE SOCKET WELD, 1/2" 316SS	2710060000	2	G
	820	Flange, Port Adapter, 1500# RAISED FACE SOCKET WELD, 1/2" 316SS	20606	2	G
	820	Flange, Port Adapter, 150# RAISED FACE SOCKET WELD, 1/2" CA 20	20119	2	H
	820	Flange, Port Adapter, 300# RAISED FACE SOCKET WELD, 1/2" CA 20	20120	2	H
	820	Flange, Port Adapter, 600# RAISED FACE SOCKET WELD, 1/2" CA 20	20121	2	H
	820	Flange, Port Adapter, RAISED FACE THREADED, 1/2" 316SS	2710044216	2	G
	-	Nipple, THREADED, 1/2 x 3 SCH40, 316SS, Use with 150 & 300# Flange	4020052053	2	G
	-	Flange, 150# RAISED FACE THREADED, 1/2" 316SS	4020013013	2	G
	-	Flange, 300# RAISED FACE THREADED, 1/2" 316SS	4020014013	2	G
	-	Flange, 600# RAISED FACE THREADED, 1/2" 316SS	4020015013	2	G
	-	Nipple, THREADED, 1/2 x 3 SCH80, 316SS, Use with 600# Flange	4020052223	2	G
	820	Flange, Port Adapter, RAISED FACE THREADED, 1/2" CA 20	2710044229	2	H
	-	Nipple, THREADED, 1/2 x 3 SCH40, CA 20, Use with 150 & 300# Flange	4020052058	2	H

- Items Not Shown

\* Double Quantity for Double Checks



FIGURE NUMBER	ITEM NUMBER	DESCRIPTION	PART NUMBER	QTY	REFERENCE CODE
3	-	Flange, 150# RAISED FACE THREADED, 1/2" CA 20	4020013017	2	H
	-	Flange, 300# RAISED FACE THREADED, 1/2" CA 20	4020014017	2	H
	-	Flange, 600# RAISED FACE THREADED, 1/2" CA 20	4020015017	2	H
	-	Nipple, THREADED, 1/2 x 3 SCH80, CA 20, Use with 600# Flange	4020052228	2	H
	830	Nut, Hex, 2/8" - 16NC, 18.8SS	4050066012	8	
	840	Washer, Spring Lock, 3/8" 18.8SS	4040041022	8	
	925	O-ring, Nitrile 70 Duro, 2-232	4080095231	1	
	990	Fitting, Strainer HPD	2450021000	1	
	1040	Valve Assy (Advise Serial & Model Number)	1010021X06	1	
	1060	Lock Washer, Spring, 5/16"	4040040028	2	
	1070	Screw, Socket Head, 5/16"-18"x2-3/4"	4050028194	2	
	1075	Barb, Air Bleed, 316SS	20352	1	G
	1075	Barb, Air Bleed, CA 20	20528	1	H
	1076	O-ring, 2-007, Viton	4080109045	1	
	1080	Plug, Pipe, 1/8 Hex HD, #6000	4020012013	1	
	2010	Gasket	2250035199	1	
	2020	Adapter, Plunger, 7/8" Hole	2720026406	1	
	2030	Plunger, Assy, 5/8" Low-Flow	20322	1	
	2050	Screw, Hex Head, 3/8"-16"x1-1/4"	4050018136	4	
	3000	Tubing, Barb, 1/2", NPT x 1/2"	4020503187	1	
3010	Tubing, 1/2"	4020296091	1		

- Items Not Shown

\* Double Quantity for Double Checks

**Illinois Location:**  
(847) 841-7867  
860 Church Rd Elgin, IL 61

**Minnesota Location:**  
(651) 758-7867  
330 Mill Bay South Suite  
Afton, MN 55001

PumpSupplyInc.com



**PS** **PUMP SUPPLY**  
INCORPORATED



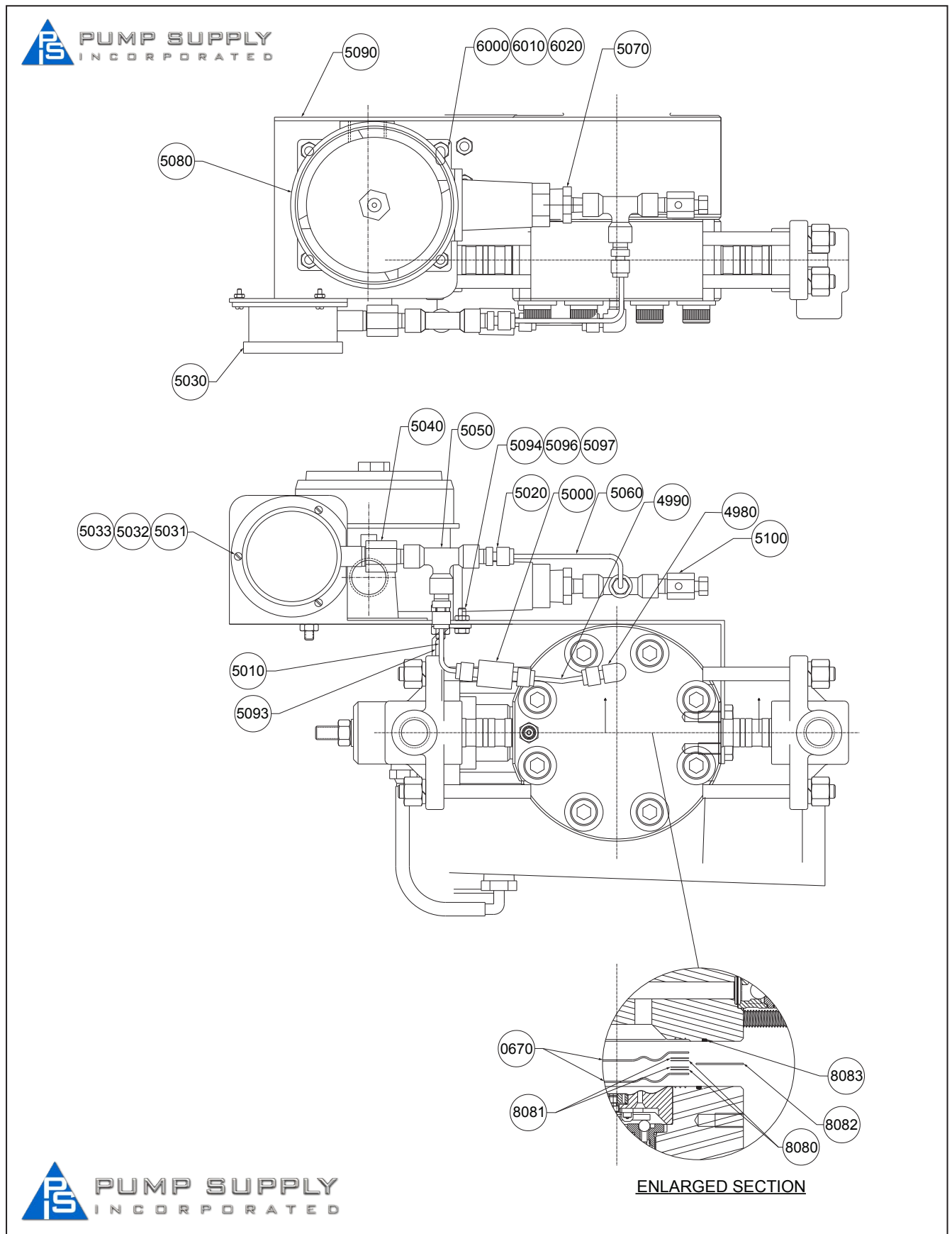

Figure 5. Milroyal® B HPD Low-Flow With Rupture Detection (DWG 102-2095-0013)

### 6.6 PARTS LIST FOR LOW-FLOW LIQUID END 7/16, 9/16, AND 5/8 PLUNGER WITH RUPTURE DETECTION

**Model:**

<u>Liquid End:</u>	<u>Material:</u>	<u>Reference Code:</u>
07, 09, 10	1, 5	C5 Rupture Detection with Gauge
07, 09, 10	1, 5	SN Rupture Detection with Gauge & NEMA 4 Switch
07, 09, 10	1, 5	SE Rupture Detection with Gauge & NEMA 7 Switch



FIGURE NUMBER	ITEM NUMBER	DESCRIPTION	PART NUMBER	QTY	REFERENCE CODE
4	670	Diaphragm, Low-Flow HPD Double Dia.	20493	2	
	4980	Elbow, Tube, 1/8" PTM X 1/8" Tube	40423	1	
	4990	Tube, Head to Valve	20495	1	
	5000	Check Valve, 1/8" Tube 1/3", 316SS	40065	1	
	5010	Tube, Valve to Gauge	20496	1	
	5020	Tube, Conn 1/8" Tubex 1/8" NPT 316SS	40061	1	
	5030	Gage, Pressure 0-5000 PSI, Dual Flange	40405	1	
	5031	Screw, Pan Head, #4-40 X 1/2"	4050263050	3	
	5032	Lock Washer, Spring, #4 18-8SS	4040095023	3	
	5033	Nut, Hex, #4 18-8SS	4050182012	3	
	5040	Adapter, Reducer, 1/4" Female X 1/8" Male, NPT 316SS	40067	1	
	5050	Tee, 1/8" NPT Female 316SS	40062	2	
	5060	Tube, Gauge to Switch	20497	1	SN, SE
	5070	Nipple, Reducer, 1/2" X 1/8", NPT 316SS	40064	1	SN, SE
	5080	Switch, NEMA 4 Pressure, 5-30 PSI	4060388001	1	SN
	5080	Switch, NEMA 7 Pressure, 5-30 PSI	4060389001	1	SE
	5090	Bracket, Support	20428	1	

- Items Not Shown

\* Double Quantity for Double Checks



FIGURE NUMBER	ITEM NUMBER	DESCRIPTION	PART NUMBER	QTY	REFERENCE CODE
4	5091	Screw, Hex Head, 5/16" - 18 X 3/4" Steel	4050017091	4	
	5092	Lock Washer, Spring, 5/16 Z Plate	4040040028	4	
	5093	Bracket, Support	22222	1	
	5094	Screw, Hex Head, 1/4"-20 X 5/8" 316SS	40415	2	
	5096	Washer, Flat, 1/4" 18-8SS	4040005012	2	
	5097	Nut, Hex, 1/4"-20NC 18-8SS	4050064012	2	
	5100	Valve, Bleed, 1/8" NPT, 316SS	40063	1	
	6000	Screw, Hex Head, 1/4"-20 X 3/4" 18-8SS	4050016095	2	SN, SE
	6010	Lock Washer, Spring, 1/4 18-8SS	4040039022	2	SN, SE
	6020	Nut, Hex, 1/4"-20NC 18-8SS	4050064012	2	SN, SE
	8080	Intermediate Ring	20431	2	
	8081	Intermediate Ring	20429	2	
	8082	Spacer Ring	20430	1	
	8083	O-Ring, 2-045, Viton 70 Duro	4080109425	1	

- Items Not Shown

\* Double Quantity for Double Checks

**Illinois Location:**  
 (847) 841-7867  
 860 Church Rd Elgin, IL 60120

**Minnesota Location:**  
 (651) 758-7867  
 330 Mill Bay South Suite 100  
 Afton, MN 55001

PumpSupplyInc.com



**PS** **PUMP SUPPLY**  
INCORPORATED

*We are a proud member of Accudyne Industries, a leading global provider of precision-engineered, process-critical, and technologically advanced flow control systems and industrial compressors. Delivering consistently high levels of performance, we enable customers in the most important industries and harshest environments around the world to accomplish their missions.*



<p><b><u>Illinois Location:</u></b> (847) 841-7867 860 Church Rd Elgin, IL 60120</p> <p><b><u>Minnesota Location:</u></b> (651) 758-7867 330 Mill Bay South Suite Afton, MN 55001</p> <p>PumpSupplyInc.com</p>	 
--	------



*an Accudyne Industries brand*

MILROYAL® is a registered trademark of Milton Roy, LLC.  
© 2015 Milton Roy, LLC.