

MILROYAL[®] SERIES

Metering Pumps

PD 3641

MILROYAL B Pumps

The MILROYAL B metering pump is a robust industrial duty metering pump for use in critical processes in oil and gas, chemical and hydrocarbon processes, water and waste treatment, and in most industries where chemical injection is required.

The MILROYAL design is modular thus allowing it to accept a variety of liquid ends and other options that perfectly tune it to process requirements. Multiplex configurations provide even greater application flexibility.

General Specifications

Drive

Polar crank design - all moving parts submerged in oil. Front end scavenging. The plunger always set to top dead center on each stroke.

Liquid Ends Available

High Performance Diaphragm (HPD); Packed Plunger; Disc Diaphragm

Accuracy

±1.0% over 10:1 turndown ratio

Maximum Performance Ratings (per head)

1.1 gph (4.21 l/h) @ 10,000 psig (689 bar) to 626 gph (2,370 l/h) @ 75 psig (5 bar)

Capacity Control

Manual micrometer standard; Electronic, pneumatic, or variable speed optional

Multiplexing

Up to 8 pumps driven by one motor. (Limited to total of 10 HP)
Consult applications engineering concerning capabilities for a specific application.

Approximate Shipping Weight (Simplex)

Approximate shipping weight is 250–600 lbs.
(113–272 kg), depending on liquid end selected.

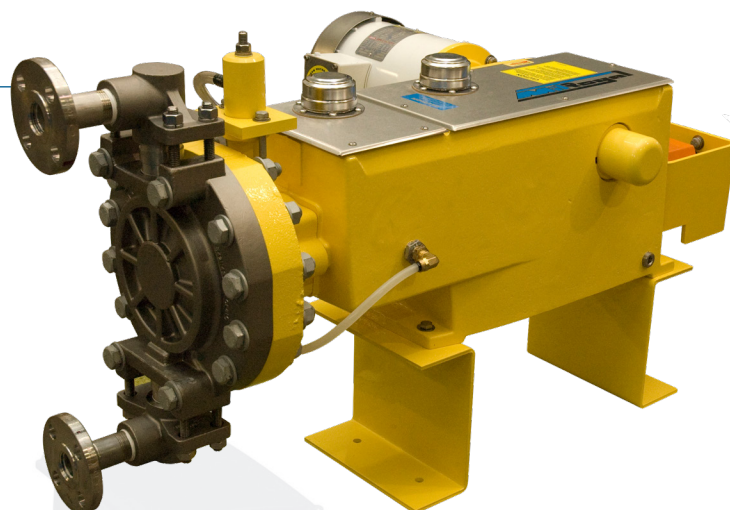

MILROYAL B Simplex with HPD Liquid End
(shown with optional flanges)

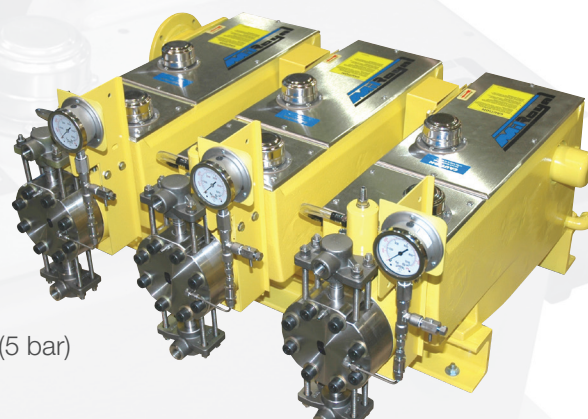

MILROYAL B Triplex
with leak detection

Illinois Location:

(847) 841-7867

860 Church Rd Elgin, IL 60123

Minnesota Location:

(651) 758-7867

330 Mill Bay South Suite 1511 Afton, MN 55001

PumpSupplyInc.com

Literature #IR-PD 3641 Rev 2022

©2016 Milton Roy, LLC. All rights reserved.



PUMP SUPPLY
INCORPORATED



MILTON ROY

An Ingersoll Rand Business

HIGH PERFORMANCE DIAPHRAGM (HPD) LIQUID END PERFORMANCE

Typical performance based on 1725 RPM, 3 Phase, 60 Hz motor. Derate flow rates for all other RPM speeds.

Plunger Diameter	Gear Ratio Code	SPM @1725 RPM	Maximum Capacity*		1/3 HP (0.25 kW)		1/2 HP (0.37 kW)		3/4 HP (0.55 kW)		1 HP (0.75 kW)		1 1/2 HP (1.1 kW)		2 HP (1.5 kW)	
					Maximum Discharge Pressure*											
					GPH	L/H	PSIG	BAR	PSIG	BAR	PSIG	BAR	PSIG	BAR	PSIG	BAR
7/16 in (11 mm)	8K 49	2.1	7	3,440	237	3,675	250	—	—	—	—	—	—	—	—	—
	8J 70	3.0	11	1,625	112	3,215	222	3,675	250	—	—	—	—	—	—	—
	8H 95	4.0	15	1,110	77	2,440	168	3,675	250	—	—	—	—	—	—	—
	8G 113	4.9	18	775	53	1,905	131	3,675	250	—	—	—	—	—	—	—
	8F 142	6.1	23	575	40	1,475	102	2,950	203	3,675	250	—	—	—	—	—
9/16 in (14 mm)	8K 49	3.8	14	1,730	118	2,780	189	3,675	250	—	—	—	—	—	—	—
	8J 70	5.4	20	975	66	1,830	124	2,750	187	3,675	250	—	—	—	—	—
	8H 95	7.3	28	650	44	1,350	92	2,030	138	3,055	208	3,675	250	—	—	—
	8G 113	8.7	33	500	34	1,125	77	1,700	116	2,730	186	3,675	250	—	—	—
	8F 142	11	42	375	26	900	61	1,350	92	2,400	163	3,600	245	3,675	250	—
5/8 in (16 mm)	8K 49	5.3	20	1,675	115	2,795	193	3,150	217	—	—	—	—	—	—	—
	8J 70	7.5	28	755	52	1,515	104	2,700	186	3,150	217	—	—	—	—	—
	8H 95	10.2	38	510	35	1,170	81	2,100	145	2,885	199	3,150	217	—	—	—
	8G 113	12.2	46	340	23	910	63	1,755	121	2,390	165	3,150	217	—	—	—
	8F 142	15.3	57	240	17	700	48	1,445	100	1,930	133	2,895	200	3,150	217	—
1 in (25 mm)	8K 49	14	53	545	38	875	60	1,250	86	—	—	—	—	—	—	—
	8J 70	19	72	305	21	575	40	860	59	1,250	86	—	—	—	—	—
	8H 95	26	98	205	14	420	29	635	44	955	66	1,250	86	—	—	—
	8G 113	31	117	160	11	355	24	535	37	850	59	1,250	86	—	—	—
	8F 142	39	148	120	8	285	20	425	29	755	52	1,130	78	1,250	86	—
1 1/4 in (32 mm)	8K 49	21	79	354	24	555	38	770	53	—	—	—	—	—	—	—
	8J 70	30	114	195	13	365	25	550	38	770	53	—	—	—	—	—
	8H 95	40	151	130	9	270	19	405	28	610	42	770	53	—	—	—
	8G 113	48	182	100	7	225	16	340	23	545	38	770	53	—	—	—
	8F 142	61	231	75	5	180	12	270	19	480	33	720	50	770	53	—
1 1/2 in (38 mm)	8K 49	34	129	220	15	350	24	500	34	—	—	—	—	—	—	—
	8J 70	48	182	120	8	230	16	345	24	500	34	—	—	—	—	—
	8H 95	65	246	80	6	170	12	255	18	385	27	500	34	—	—	—
	8G 113	77	291	60	4	140	10	215	15	340	23	500	34	—	—	—
	8F 142	97	367	45	3	110	8	170	12	300	21	455	31	500	34	—
2 in (51 mm)	8K 49	52	197	140	10	225	16	300	21	—	—	—	—	—	—	—
	8J 70	75	284	75	5	145	10	220	15	300	21	—	—	—	—	—
	8H 95	101	382	50	3	105	7	160	11	245	17	300	21	—	—	—
	8G 113	120	454	—	—	90	6	135	9	220	15	300	21	—	—	—
	8F 142	151	572	—	—	70	5	105	7	190	13	300	21	360	25	—
2 1/2 in (64 mm)	8K 49	83	314	85	6	140	10	165	11	—	—	—	—	—	—	—
	8J 70	119.4	50	50	3	90	6	140	10	165	11	—	—	—	—	—
	8H 95	161	609	—	—	65	4	100	7	155	11	165	11	—	—	—
	8G 113	191	723	—	—	55	4	85	6.1	35	9	165	11	—	—	—
	8F 142	240	908	—	—	—	—	65	4	120	8	105	11	—	—	—
3 1/2 in (89 mm)	8K 49	170	643	—	—	70	5	100	7	—	—	—	—	—	—	—
	8J 70	242	916	—	—	—	—	65	4	100	7	—	—	—	—	—
	8H 95	330	1,249	—	—	—	—	50	3	75	5	100	7	—	—	—
	8G 113	391	1,480	—	—	—	—	—	—	65	4	100	7	—	—	—
	8F 142	500	1,892	—	—	—	—	—	—	60	4	90	6	100	7	—
4 in (102 mm)	8K 49	216	820	—	—	50	3	75	5	—	—	—	—	—	—	—
	8J 70	308	1,165	—	—	—	—	50	3	75	5	—	—	—	—	—
	8H 95	419	1,585	—	—	—	—	—	—	60	4	75	5	—	—	—
	8G 113	498	1,885	—	—	—	—	—	—	50	3	75	5	—	—	—
	8F 142	626	2,370	—	—	—	—	—	—	45	3	70	5	75	5	—

Capacities listed are for discharge pressures up to 2,000 PSIG (137 Bar).
 Derate capacities by 6% for each 1,000 PSIG (68 Bar) over 2,000 PSIG (137 Bar).

NOTES: * For single phase motors, increase horsepower by one size — example: increase 1/2 hp (0.37 kW) to 3/4 hp (0.55 kW).
 † Plastic liquid ends are limited to 150 PSIG (10 Bar) @ 68°F (20°C) and are linearly derated to 65 PSIG (4 Bar) @ 140°F (60°C).
 ‡ Derate capacity by 5% when applying a diaphragm rupture detection system.



HPD LIQUID END DIMENSIONS

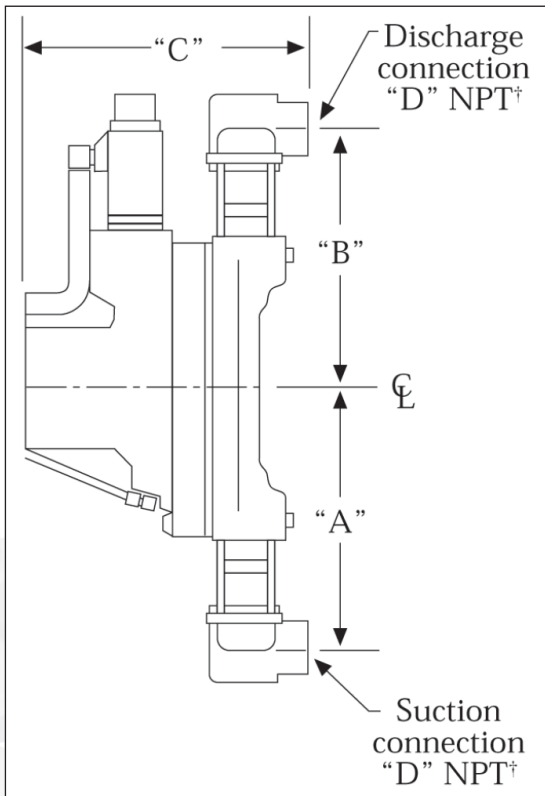

For exact dimensions, request a certified drawing

Material	Plunger Diameter		A [†]		B [†]		C*		D
	in.	mm	in.	mm	in.	mm	in.	mm	in.
Metal (Double Ball) Standard	7/8	11	5 5/8	121	5 5/8	121	4	102	1/2
	9/16	14	5 5/8	121	5 5/8	121	4	102	1/2
	5/8	16	5 5/8	121	5 5/8	121	4	102	1/2
Metal (Single Ball) Standard	1	25	4 19/16	122	4 19/16	122	6 1/8	156	1/2
	1 1/4	32	5 17/32	133	5 7/32	133	6 1/8	156	1/2
	1 1/2	38	7 1/16	179	7 1/16	179	8 1/4	210	1
	2	51	7 9/16	192	7 9/16	192	8 1/4	210	1
	2 1/2	64	7 9/16	192	7 9/16	192	8 1/4	210	1
	3 1/2	89	10 1/8	257	10 1/8	257	13	330	1 1/2
	4	102	10 1/8	257	10 1/8	257	13	330	1 1/2
Plastic (Double Ball) Standard	1	25	6 1/2	165	6 1/2	165	6 15/16	176	1/2
	1 1/4	32	6 1/2	165	6 1/2	165	6 15/16	176	1/2
	1 1/2	38	9 9/16	243	9 9/16	243	8 3/4	222	1
	2	51	9 9/16	243	9 9/16	243	8 3/4	222	1
	2 1/2	64	9 9/16	243	9 9/16	243	8 3/4	222	1
	3 1/2	89	16 [†]	406 [†]	13	330	13 1/4 [†]	337 [†]	1 1/2
	4	102	16 [†]	406 [†]	13	330	13 1/4 [†]	337 [†]	1 1/2

Notes:

- * Dimensions shown are for single diaphragm liquid ends. Contact factory for double diaphragm dimensions.
- † A & B dimensions are based on standard ball check configuration: Consult factory for dimensions on optional configurations.
- ‡ Suction and discharge connections are horizontal in metal and vertical in plastic except on plastic 3 1/2 in (89 mm) plunger & 4 in (102 mm) plunger, where suction is horizontal, discharge is vertical and dimension "C" for discharge is 10 13/16 in (275 mm).

MAXIMUM ALLOWABLE SUCTION PRESSURE RANGE — HPD

Plunger Diameter		Standard		Mid Range		High Range	
in.	mm	PSIG	Bar	PSIG	Bar	PSIG	Bar
7/16	11	660	46	1,130	77	1,450	98
9/16	14	460	31	770	53	985	68
5/8	16	360	25	590	40	750	51
1	25	100	7	—	—	—	—
1 1/4	32	100	7	—	—	—	—
1 1/2	38	85	6	100	7	—	—
2	51	60	4	85	6	100	7
2 1/2	64	45	3	60	4	70	5
3 1/2	89	20	1.3	35	2	40	3
4	100	15	1	25	1.5	30	2





HIGH PERFORMANCE DIAPHRAGM (HPD) LIQUID END MODEL CODE

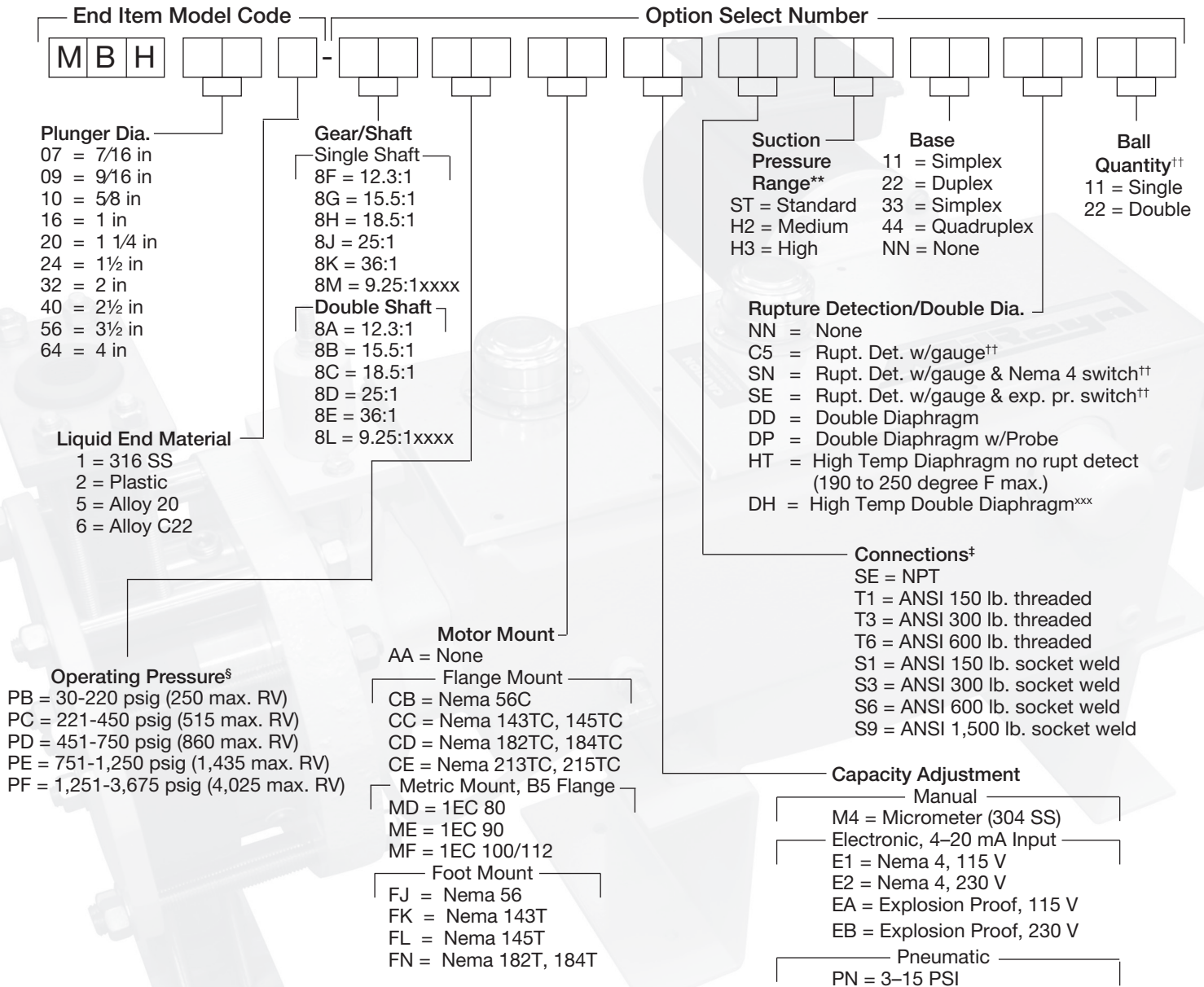

NOTES:

- § Operating pressure is the application system pressure. The internal relief valve is normally set 15% above the operating pressure. If an internal relief valve setting greater than 15% above the operating pressure range is required, select the operating pressure range that will accommodate the relief valve setting.
- ‡ Flange sizes equal the NPT connection size as noted on the liquid end drawing.
- † Options C5, SN, and SE are only available on metallic liquid ends.
- †† Options C5, SN, and SE are only available on metallic liquid ends.
- * Plastic liquid ends are only available with double ball checks.
- xxx Plunger diameter 1 in and above only.
- xxxx 50 Hz only.





DISC DIAPHRAGM LIQUID END PERFORMANCE

Typical performance based on 1725 RPM, 3 Phase, 60 Hz motor. Derate flow rates for all other RPM speeds.

Plunger Diameter	Gear Ratio Code	SPM @1725 RPM	Maximum Capacity*		Maximum Discharge Pressure*											
					1/3 HP (0.25 kW)		1/2 HP (0.37 kW)		3/4 HP (0.55 kW)		1 HP (0.75 kW)		1 1/2 HP (1.1 kW)		2 HP (1.5 kW)	
			GPH	L/H	PSIG	BAR	PSIG	BAR	PSIG	BAR	PSIG	BAR	PSIG	BAR	PSIG	BAR
7/16 in (11 mm)	8K	49	2.1	7	3,440	237	3,500	241	—	—	—	—	—	—	—	—
	8J	70	3.0	11	1,625	112	3,215	222	3,500	241	—	—	—	—	—	—
	8H	95	4.0	15	1,110	77	2,440	168	3,500	241	—	—	—	—	—	—
	8G	113	4.9	18	775	53	1,905	131	3,500	241	—	—	—	—	—	—
	8F	142	6.1	23	575	40	1,475	102	2,950	203	3,500	241	—	—	—	—
5/8 in (16 mm)	8K	49	5.3	20	1,675	115	2,795	193	3,150	217	—	—	—	—	—	—
	8J	70	7.5	28	755	52	1,515	104	2,100	186	3,150	217	—	—	—	—
	8H	95	10.2	38	510	35	1,170	81	1,755	145	2,885	199	3,150	217	—	—
	8G	113	12.2	46	340	23	910	63	3,245	121	2,390	165	3,150	217	—	—
	8F	142	15.3	57	240	17	700	48	1,445	100	1,930	133	2,895	200	3,150	217
7/8 in (22 mm)	8K	49	9.6	36	800	55	1,385	95	1,500	103	—	—	—	—	—	—
	8J	70	13.8	52	350	24	750	52	1,320	91	1,500	103	—	—	—	—
	8H	95	18.6	70	225	16	560	39	1,025	71	1,500	103	—	—	—	—
	8G	113	22.0	83	140	10	425	29	850	59	1,205	83	1,500	103	—	—
	8F	142	27.6	104	90	6	345	24	740	51	985	68	1,500	103	—	—
1 1/8 in (28 mm)	8K	49	16.2	61	460	32	810	56	900	62	—	—	—	—	—	—
	8J	70	23.0	87	185	13	430	30	770	53	900	62	—	—	—	—
	8H	95	31.4	118	115	8	310	21	590	41	900	62	—	—	—	—
	8G	113	37.0	140	65	4	230	16	485	33	720	50	900	62	—	—
	8F	142	47.5	179	35	2	185	13	420	29	595	41	900	62	—	—
1 1/2 in (38 mm)	8K	49	28.5	107	2	40	17	435	30	500	34	—	—	—	—	—
	8J	70	41.0	155	90	6	225	16	420	29	500	34	—	—	—	—
	8H	95	56.0	212	45	3	160	11	315	22	500	34	—	—	—	—
	8G	113	67.0	253	—	—	115	8	255	18	400	28	500	34	—	—
	8F	142	84.0	317	—	—	90	6	225	16	335	23	500	3	4	—
1 3/4 in (44 mm)	8K	49	39.0	147	175	12	320	22	360	25	—	—	—	—	—	—
	8J	70	55.8	211	55	4	155	11	295	20	360	25	—	—	—	—
	8H	95	76	287	—	—	110	8	225	16	360	25	—	—	—	—
	8G	113	91	344	—	—	75	5	180	12	270	19	360	25	—	—
	8F	142	114	431	—	—	60	4	155	11	220	15	360	25	—	—
2 1/2 in (64 mm)	8K	49	83	314	70	5	145	10	165	11	—	—	—	—	—	—
	8J	70	119	451	—	—	60	4	135	9	165	11	—	—	—	—
	8H	95	161	609	—	—	40	3	95	7	165	11	—	—	—	—
	8G	113	190	719	—	—	—	—	70	5	125	9	165	11	—	—
	8F	142	240	908	—	—	—	—	65	4	95	7	165	11	—	—

Capacities listed are for discharge pressures up to 2,000 PSIG (137 Bar).
Derate capacities by 6% for each 1,000 PSIG (68 Bar) over 2,000 PSIG (137 Bar).

NOTES::

- * For single phase motors, increase horsepower by one size — example: increase 1/2 hp (0.37 kW) to 3/4 hp (0.55 kW).
- † Plastic liquid ends are limited to 150 PSIG (10 Bar) @ 68°F (20°C) and are linearly derated to 65 PSIG (4 Bar) @ 140°F (60°C).





DISC DIAPHRAGM LIQUID END DIMENSIONS

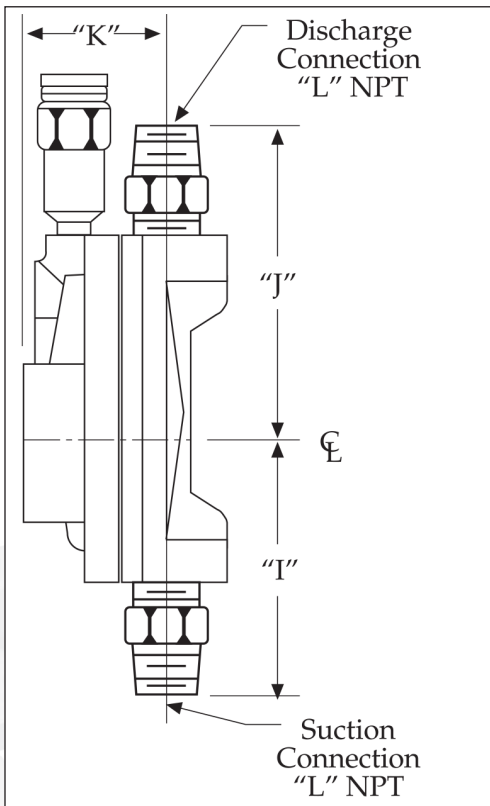

Material	Plunger Diameter		I		J		K		L
	in.	mm	in.	mm	in.	mm	in.	mm	in.
Metal	7/16	11	4 3/4	121	5 1/2	140	3	76	1/2
	5/8	16	4 3/4	121	5 1/2	140	3	76	1/2
	7/8	22	5 3/4	146	6 7/8	175	3 7/16	87	1
	1 1/8	28	5 3/4	146	6 7/8	175	3 7/16	87	1
	1 1/2	38	6 7/16	164	7 15/16	202	3 5/8	92	1 1/4
	1 3/4	44	6 7/16	164	7 15/16	202	3 5/8	92	1 1/4
	2 1/2	64	6 15/16	176	107 5/16	265	3 7/8	98	1 1/2
Plastic	7/16	11	4 1 1/16	119	5 7/16	138	3 3/16	81	1/2
	5/8	16	4 1 1/16	119	5 7/16	138	3 3/16	81	1/2
	7/8	22	5 1/4	133	6 3/8	162	3 1/2	89	1
	1 1/8	28	5 1/4	133	6 3/8	162	3 1/2	89	1
	1 1/2	38	6 15/16	176	8 7/16	214	3 7/16	98	1 1/4
	1 3/4	44	6 15/16	176	8 7/16	214	3 7/16	98	1 1/4
	2 1/2	64	7 7/16	189	10 15/16	278	4 1/16	103	1 1/2

NOTES:

* Dimensions shown are for single diaphragm liquid ends. Contact factory for double diaphragm dimensions.

MAXIMUM ALLOWABLE SUCTION PRESSURE RANGE – Disc Diaphragm

Plunger Diameter		Maximum Range	
in.	mm	PSIG	Bar
7/16	11	660	46
5/8	16	360	25
7/8	22	208	14
1 1/8	28	142	10
1 1/2	38	94	6
1 3/4	44	75	5
2 1/2	64	46	3





MILROYAL B DISC DIAPHRAGM LIQUID END MODEL CODE

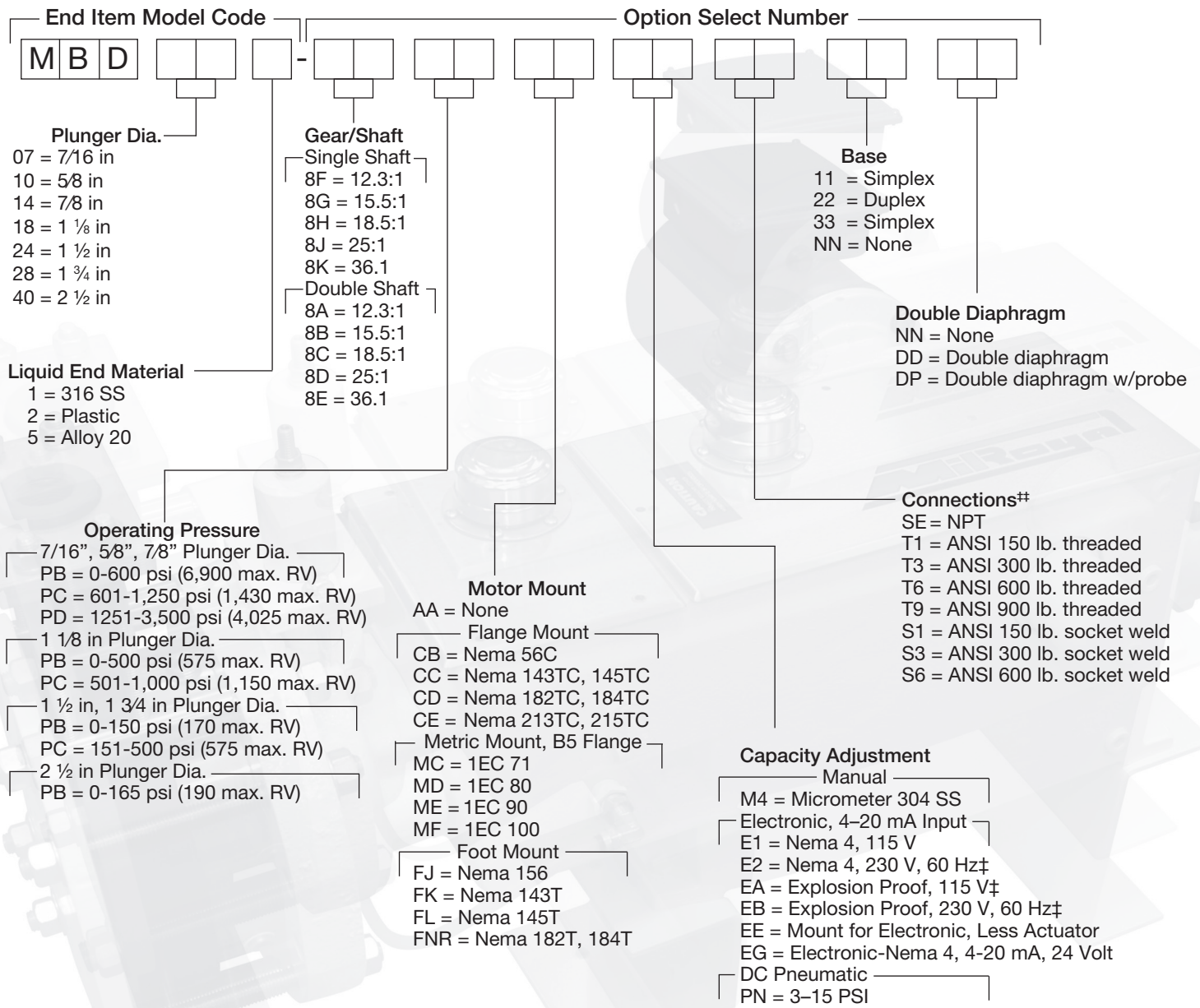

NOTES:

* Operating pressure is the pressure of the applications system. The internal relief valve is normally set 15% above the operating If an pressure. If an internal relief valve setting greater than 15% above the operating pressure range is required, select the operating pressure that will accommodate the relief valve setting.

† Flange sizes equal the NPT connection size as noted on the liquid end drawing.

1. Double ball checks are standard.

xx 50 Hz only.





PACKED PLUNGER LIQUID END PERFORMANCE

Typical performance based on 1725 RPM, 3 Phase, 60 Hz motor. Derate flow rates for all other RPM speeds.

Plunger Diameter	Gear Ratio Code	SPM @1725 RPM	Maximum Capacity*		1/3 HP (0.25 kW)		1/2 HP (0.37 kW)		3/4 HP (0.55 kW)		1 HP (0.75 kW)		1 1/2 HP (1.1 kW)		2 HP (1.5 kW)	
					Maximum Discharge Pressure*											
			GPH	L/H	PSIG	BAR	PSIG	BAR	PSIG	BAR	PSIG	BAR	PSIG	BAR	PSIG	BAR
5/16 in (8 mm)	8K	49	1.1	4	4,470	308	7,500	517	10,000	689	—	—	—	—	—	—
	8J	70	1.6	6	3,130	216	5,870	405	7,500	517	10,000	689	10,000	—	—	—
	8H	95	2.2	8	2,115	146	4,470	308	7,500	517	10,000	689	10,000	—	—	—
	8G	113	2.7	10	1,535	106	3,635	251	6,545	451	7,500	517	7,500	689	—	—
	8F	142	3.4	12	1,155	80	3,085	213	5,210	359	6,945	479	6,945	517	10,000	689
7/16 in (11 mm)	8K	49	2.2	8	2,280	157	4,280	295	6,450	445	—	—	—	—	—	—
	8J	70	3.2	12	1,595	110	2,995	207	4,790	330	6,450	445	—	—	—	—
	8H	95	4.4	16	1,030	71	2,280	157	3,860	266	5,150	355	6,450	445	—	—
	8G	113	5.3	20	740	51	1,855	128	3,245	224	4,330	299	6,450	445	—	—
	8F	142	6.6	25	525	36	1,575	109	2,655	183	3,545	244	5,315	366	6,450	445
5/8 in (16 mm)	8K	49	5.0	18	1,120	77	2,095	144	3,175	219	—	—	—	—	—	—
	8J	70	7.1	26	755	52	1,465	101	2,350	162	3,175	219	—	—	—	—
	8H	95	9.6	36	480	33	1,080	74	1,840	127	2,450	169	3,175	219	—	—
	8G	113	11.5	43	325	22	880	61	1,545	107	2,060	142	3,090	213	3,175	219
	8F	142	14.4	54	225	16	745	51	1,300	90	1,735	175	1,735	279	—	—
7/8 in (22 mm)	8K	49	10.1	38	570	39	995	69	2260	107	—	—	—	—	—	—
	8J	70	14.4	54	345	24	720	50	1575	80	1,555	107	—	—	—	—
	8H	95	19	74	205	14	530	37	1250	63	1,210	83	1,555	107	—	—
	8G	113	23	87	120	8	415	29	940	53	1,020	70	—	—	—	—
	8F	142	29	109	80	6	340	23	845	45	885	61	1,325	91	1,555	107
1 1/8 in (28 mm)	8K	49	17	64	335	23	580	40	1270	63	—	—	—	—	—	—
	8J	70	24	90	190	13	420	29	885	45	915	63	—	—	—	—
	8H	95	33	124	100	7	285	20	690	37	710	49	915	63	—	—
	8G	113	39	147	50	3	220	15	520	31	595	63	595	94	—	—
	8F	142	50	189	—	—	175	12	465	26	505	35	755	52	915	63
1 1/2 in (38 mm)	8K	49	30	113	160	11	315	22	725	35	—	—	—	—	—	—
	8J	70	44	166	90	6	220	15	475	23	505	35	—	—	—	—
	8H	95	59	223	—	—	150	10	370	19	375	26	505	35	—	—
	8G	113	70	265	—	—	110	82	29	16	315	745	315	—	—	—
	8F	142	88	333	—	—	80	6	245	14	265	18	400	28	505	35
1 3/4 in (44 mm)	8K	49	41	155	110	8	220	15	360	25	—	—	—	—	—	—
	8J	70	59	223	50	3	155	11	250	17	360	25	—	—	—	—
	8H	95	80	302	—	—	90	6	200	14	265	18	360	25	—	—
	8G	113	95	359	—	—	70	5	170	11	215	21 3	215	27	—	—
	8F	142	120	454	—	—	45	3	125	9	170	12	255	18	360	25
2 1/2 in (64 mm)	8K	49	85	323	—	—	100	7	165	11	—	—	—	—	—	—
	8J	70	121	458	—	—	60	4	105	7	165	11	—	—	—	—
	8H	95	164	620	—	—	—	—	80	6	105	7	165	11	—	—
	8G	113	195	738	—	—	—	—	55	4	75	5	135	9	165	11
	8F	142	245	927	—	—	—	—	50	3	65	4	105	7	165	11

Capacities listed are for discharge pressures up to 2,000 PSIG (137 Bar).
Derate capacities by 6% for each 1,000 PSIG (68 Bar) over 2,000 PSIG (137 Bar).

NOTES:

* For single phase motors, increase horsepower by one size — example: increase 1/2 hp (0.37 kW) to 3/4 hp (0.55 kW).





PACKED PLUNGER LIQUID END DIMENSIONS*

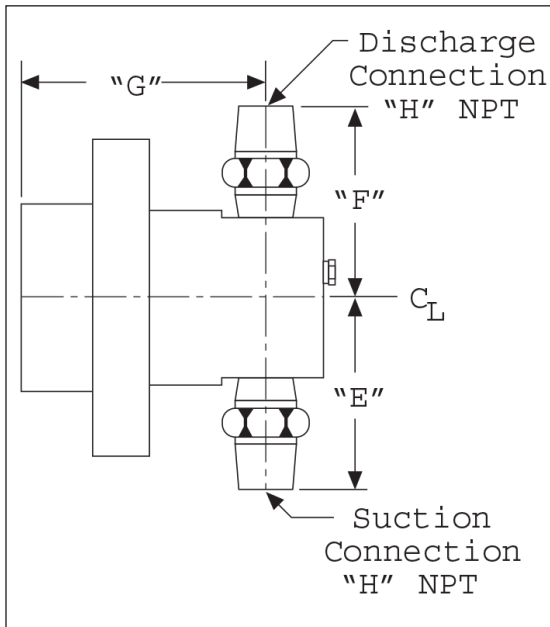

Pressure	Plunger Diameter		E		F		G		H
	in.	mm	in.	mm	in.	mm	in.	mm	in.
0-4,999 PSIG (0-344 BAR)	5/16	08	3	76	3	76	4 1/4	108	1/2
	7/16	11	3	76	3	76	4 1/4	108	1/2
	5/8	16	3	76	3 1/4	89	4 1/4	108	1/2
	7/8	22	3 1/2	90	3 1/2	89	4 1/4	108	1/2
	1 1/8	28	3 9/16	90	3 9/16	90	4	102	1
	1 1/2	38	4 7/16	113	4 7/16	113	4	102	1 1/4
	1 3/4	44	4 7/16	113	4 7/16	113	4	102	1 1/4
5,000+ PSIG (345+ BAR)	2 1/2	64	7 3/8	184	7 3/8	187	7 1/2	184	2 1/2
	5/16	08	3 5/16	84	3 5/16	84	4 1/2	114	3/4
	7/16	11	3 5/16	84	3 5/16	84	4 1/2	114	3/4

For exact dimensions, request a certified drawing

MAXIMUM ALLOWABLE SUCTION PRESSURE RANGE — Packed Plunger

Plunger Diameter		Standard		Mid Range		High Range	
in.	mm	PSIG	Bar	PSIG	Bar	PSIG	Bar
5/16	08	1,180	81	2,120	146	2,750	190
7/16	11	660	46	1,130	78	1,450	100
5/8	16	360	25	590	41	750	52
7/8	22	208	14	330	23	410	28
1 1/8	28	142	10	215	15	265	18
1 1/2	38	94	6	135	9	165	11
1 3/4	44	75	5	104	7	125	9
2 1/2	64	46	3	60	4	70	5





PACKED PLUNGER LIQUID END MODEL CODE

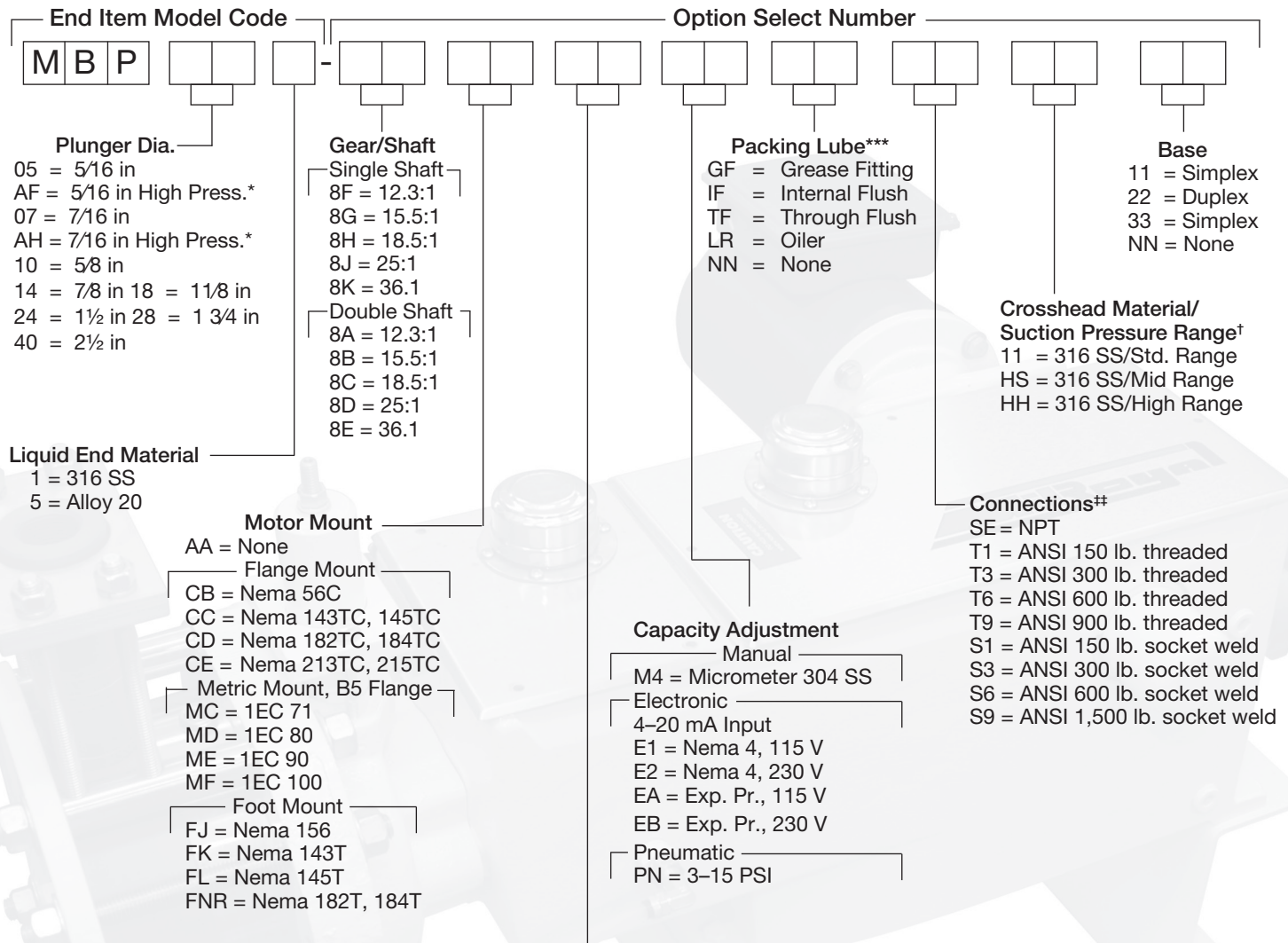

Code	Description	Type	Plunger Range	PSI Range*	Plunger Materials	Oiler Suggested?
TM	PTFE 5022 AFP	Compression- User adjust required	5/16 to 7/8 in 1 1/8 to 2 1/2 in	0 to 1,500	316ss or A 20 (Same as Liquid end)	No
BC	PTFE Braid 5022 AFP				Ceramic	
NM	Nitrile Fabric	V-Ring	1 1/8 to 2 1/2 in 1 1/8 to 2 1/2 in	0 to 10,000*	316ss	Yes
NR	Nitrile Fabric				Ceramic	
TR	PTFE	Spring load self adjust	5/16 to 7/8 in	0 to 10,000*	Ceramic	Yes

NOTES:

- * Plunger diameter Codes BA, AH, 24, 32, 40, 56 & 71 are available in 316 SS only. Other liquid end materials can be quoted by the Milton Roy application engineering department. High pressure plunger diameter codes are for applications requiring pressures over 5,000 psi.
- ** Packing code NM is a standard option for 316 SS liquid ends with plunger diameters of 1 1/2 in and larger.
- *** Select packing lube GF with packing codes TM & NM. Contact applications engineering for other packing lube selection.
- † Refer to suction pressure table for suction pressure versus range.
- †† Flange sizes equal the NPT connection size as noted on the liquid end drawing.
- ‡ Alloy 20 liquid ends are available standard with packing code TM. Contact applications engineering for other packings or plunger materials with Alloy 20 liquid ends.
- ‡‡ The plunger material will automatically match the liquid end material when selecting packing/plunger material code TM.
- § Packing/plunger codes AL, TL, & VL are offered on 316 SS liquid ends with 7/16 in through 1 1/8 in plunger diameters. Contact Milton Roy applications engineering to apply to other plunger diameters or liquid end materials.
- §§ Packing/plunger codes AR, TR, & VR are offered on 316 SS liquid ends with 7/16 in and 5/8 in high pressure plunger diameters. Contact Milton Roy applications engineering to apply to other plunger diameters or liquid end materials.
- §§§ Explosion proof electronic actuators are certified by Factory Mutual for Class I, Division I, Groups B, C, & D; Class II, Division I, Groups E, F, & G.



HPD MATERIALS OF CONSTRUCTION – WETTED PARTS

Materials of Construction	Diaphragm	Diaphragm Head	Port Connection	Ball Seat	Ball Check	Ball Guide
316 SS‡	PTFE/Elastomer	316 SS CF-8M	316 SS CF-8M	316 SS	316 SS	316 SS CF-8M§
Alloy 20‡	PTFE/Elastomer	20Cb-D3 CN-7M**	20Cb-D3 CN-7M**	20Cb-3	20Cb-3	20Cb-D3 CN-7M*
Plastic‡	PTFE/Elastomer	PVC*	PVC	PVC	Ceramic†	PVC
Alloy C22‡	PTFE/Elastomer	Alloy C22 CX2MW††	Alloy C22 CX2MW††	Alloy C22	Alloy C276	Alloy C22 CX2MW††

NOTES:

- * Temperature range for metallic versions is 10°F (-12°C) to 190°F (88°C) standard, optional to 225°F (107°C), special to 300°F (149°C). Temperature range for plastic versions is 10°F (-12°C) to 140°F (60°C).
- ‡ CF-8M is the cast equivalent to wrought 316 SS.
- § CN-7M is the cast equivalent to wrought 20CB-3.
- † CX2MW is the cast equivalent to wrought Alloy C22.

DISC DIAPHRAGM MATERIALS OF CONSTRUCTION – WETTED PARTS

Materials of Construction	Diaphragm Head	Cartridge Body	Seats	Balls	Limit Pins	Diaphragm	Contour Plate
316 SS*	316 SS CF-8M†	316 SS CF-8M†	316 SS	316 SS	316 SS	PTFE	316 SS CF-8M†
Alloy 20*	20Cb-D3 CN-7M*	20Cb-D3 CN-7M†	Alloy 20	Alloy 20	Alloy 20	PTFE	20Cb-D3 CN-7M‡
Plastic	Acrylic Plastic*	PVC	PVC	Ceramic	Alloy 20	PTFE	(none)

NOTES:

- * Diaphragm head is polypropylene on plastic 2½ in.
- † Maximum temperature for metallic liquid ends is 250°F (121°C). Maximum temperature for plastic liquid ends is 140°F (60°C).
- ‡ CF-8M is the cast equivalent to wrought 316 SS.
- § CN-7M is the cast equivalent to wrought 20CB-3.

PACKED PLUNGER MATERIALS OF CONSTRUCTION – WETTED PARTS

Liquid End Material	Plunger	Check Valve	Seat	Seat Seal	Ball	Liquid End Material	Packing Spring	Gland Cap
316 SS‡	316 SS (to 1,500 psi)	316 SS CF-8M*	316 SS	PTFE	316 SS	316 SS CF-8M*	N/A	316 SS CF-8M*
	Colmonoy (to 5,000 psi)	316 SS CF-8M*	316 SS	PTFE	316 SS	316 SS CF-8M*	316 SS	316 SS CF-8M*
	Carbide (to 10,00 psi)	316 SS CF-8M§	Hardened 13-4 Mo	PTFE	Carbide	316 SS CF-8M*	316 SS	316 SS CF-8M*
Alloy 20	20Cb-3 (to 1,500 psi)	20Cb-3 CN-7M*	20Cb-3	PTFE	20Cb-3	20Cb-D3 CN-7M†	N/A	20Cb-D3 CN-7M†

NOTES:

- * CF-8M is the cast equivalent to wrought 316 SS.
- † CN-7M is the cast equivalent to wrought 20Cb-3 SS.

Illinois Location:
(847) 841-7867
860 Church Rd Elgin, IL 60120

Minnesota Location:
(651) 758-7867
330 Mill Bay South Suite
Afton, MN 55001

PumpSupplyInc.com



PUMP SUPPLY
INCORPORATED

DRIVE DIMENSIONS

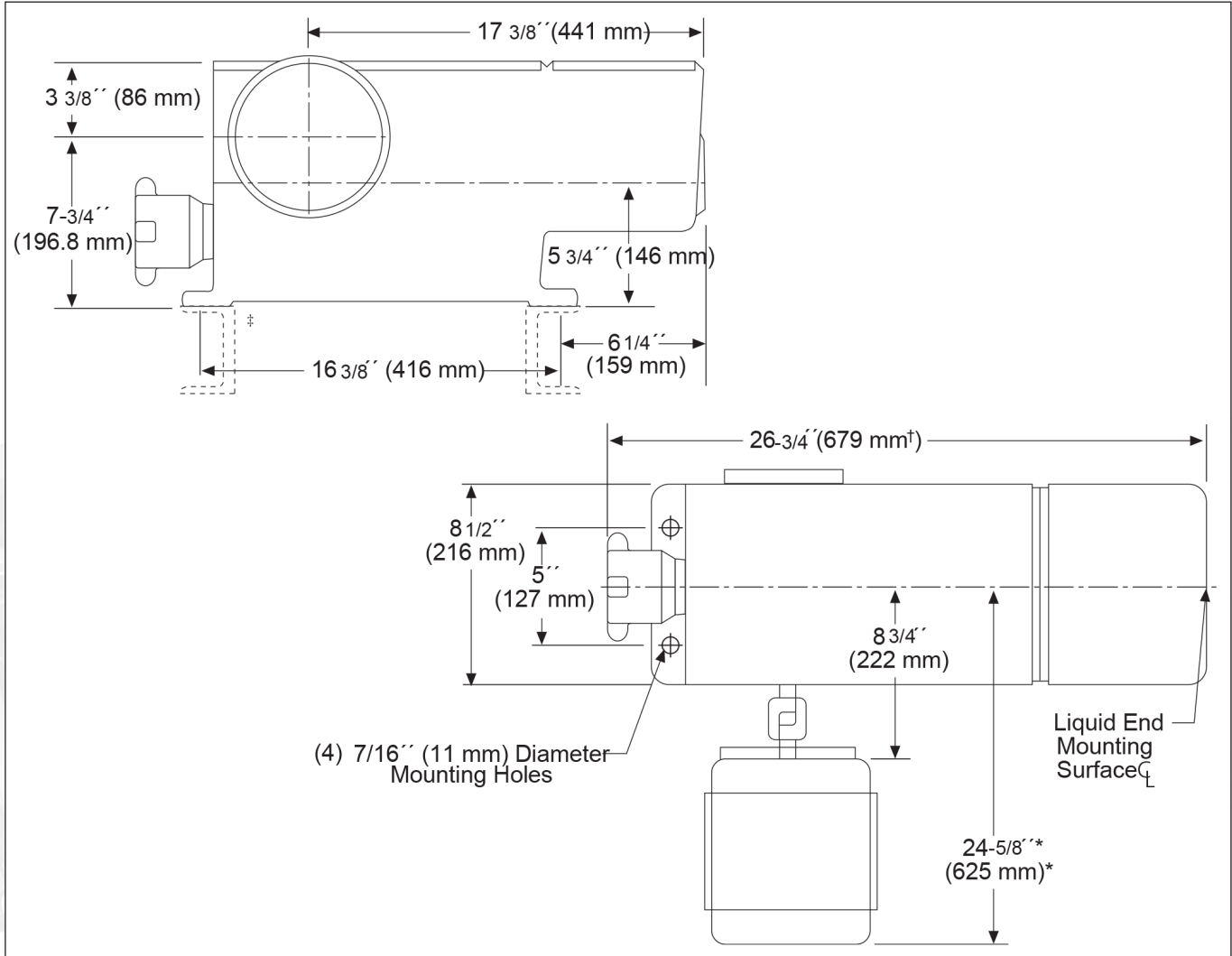

NOTES:

* Dimension shown is for the largest available motor.

‡ Various bases are supplied with certain liquid ends and multiplex units. Consult factory for exact mounting dimensions.

† 26 3/4 in (679 mm) is the dimension for manual stroke adjustment. For electronic stroke, overall length is 41 5/8 in (1,311 mm).

AVAILABLE OPTIONS

- Double diaphragm
- Diaphragm rupture detection system
- Flanged connections
- Electronic capacity control
- Pneumatic capacity control
- Severe duty motors
- Variable speed drives
- Other options available to fit your application

ACCESSORIES

- Safety valves
- Back pressure valves
- Calibration columns
- Pulsation dampeners
- Tanks & standard systems
- Sludge traps

Illinois Location:

(847) 841-7867
860 Church Rd Elgin, IL 60120

Minnesota Location:

(651) 758-7867
330 Mill Bay South Suite 100
Afton, MN 55001

PumpSupplyInc.com

