

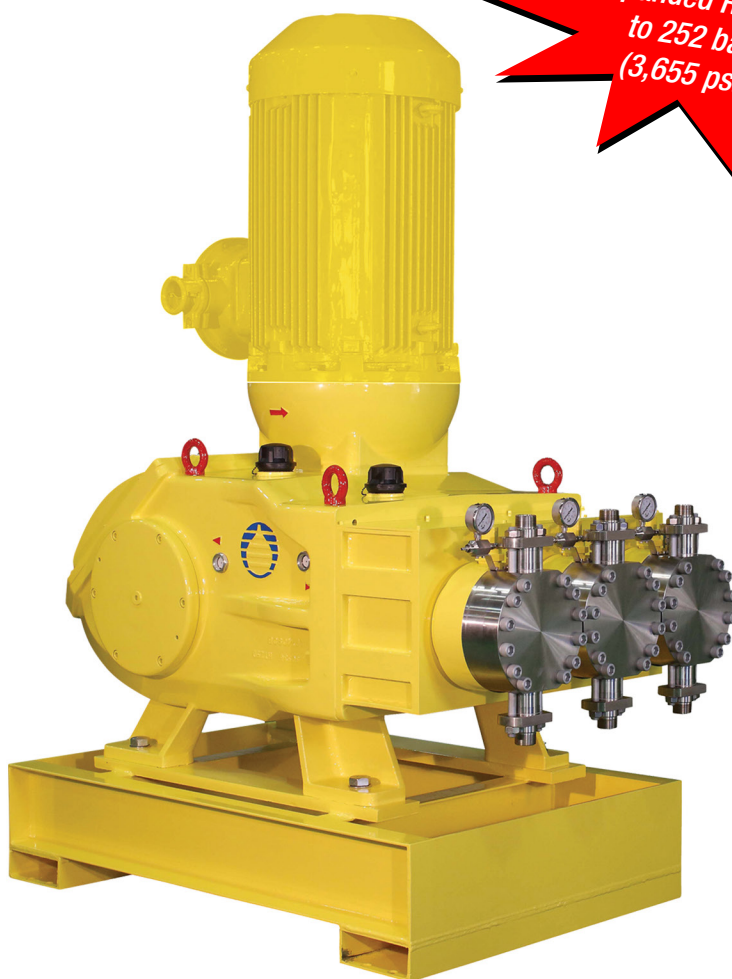

MEGARoyal® Series Diaphragm Process Pump

*Expanded Range
to 252 bar
(3,655 psi)*



*The **Power** to Perform*

Optimal leak-proof performance for high-volume chemical injection

Designed for your most critical industrial processing needs, the MEGARROYAL process pump provides a reliable, leak-proof performance in a convenient design.

Engineered for the injection and transfer of hazardous chemicals, the MEGARROYAL is capable of handling flow rates of up to 12,680 gph or 211 gpm (48 m³/h or 800 L/min) with discharge pressures to 3,655 psi (252 bar) in a footprint that is up to 25% smaller when compared to similar competitive options.

The MEGARROYAL pump provides the reliability you expect from Milton Roy with the power you want to meet all your chemical dosing needs.



Applications:

- Oil & Gas – applications requiring high pressure liquid injection and transfer to prevent hydrate formation, reduce corrosion, scales and much more.
- Chemical and Petrochemical Processing – metering of chemicals in refinery processes such as separation / distillation, transformation / conversion and finishing/refining of products.
- Water Treatment and General Industry - Slurry fluid transfer such as bauxite, coal water slurry and sewage.
- Ideal for industries requiring zero-leakage and control of critical process liquids.

Specifications:

- Maximum capacity: 12,680 gph or 211 gpm (48 m³/h or 800 L/min)
- Maximum discharge pressure: 3,655 psi (252 bar)
- Maximum motor power: 100 hp (75 kW)
- Pumped fluid temperature: 14°F to 203°F (-10°C to 95°C)
- Capacity adjustment: By variable frequency drive (VFD) with variable frequency motor

Features and Benefits:

- High reliability in critical chemical delivery applications for optimum performance.
- Compact design with a 25% smaller footprint, making it the right fit when space is limited.
- Patented diaphragm design with service life of over 20,000 hours reduces maintenance costs while protecting against leakages.
- Unique lubrication system reduces wear, minimizes maintenance, and extends equipment life.
- Equipped with a double-diaphragm detection system to monitor via local or remote alarm in the unlikely event of a rupture.
- API 675 compliant*

*Consult factory for details



PUMP SUPPLY
INCORPORATED

Flow and Pressure Range

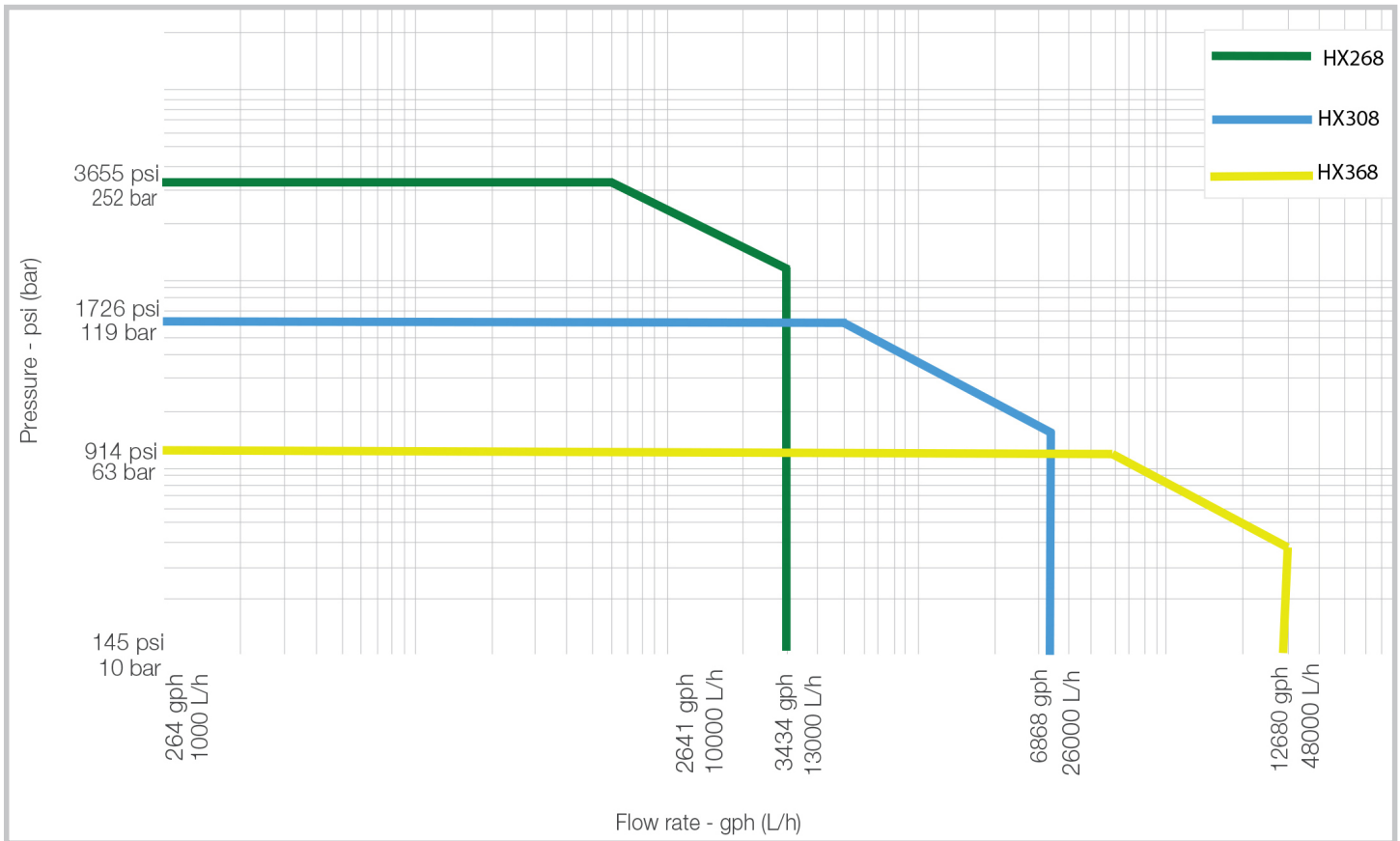

HX268



Application: Chemicals
 Fluid: Heavy Oil
 Temp: 166° F / 130° C
 Capacity: 39.6 & 50.6 gph / 9 m³/h & 11.5 m³/h
 Pressure: 1,465 psig / 101 barg
 Motor Power: 55kW/75kW

HX308



Application: Oil & Gas
 Fluid: Condensate
 Temp: 98° F / 36.5° C
 Capacity: 6.6 - 79.5 gph / 3.78-18 m³/h
 Pressure: 667 psig / 46 barg
 Motor Power: 45kW

HX368

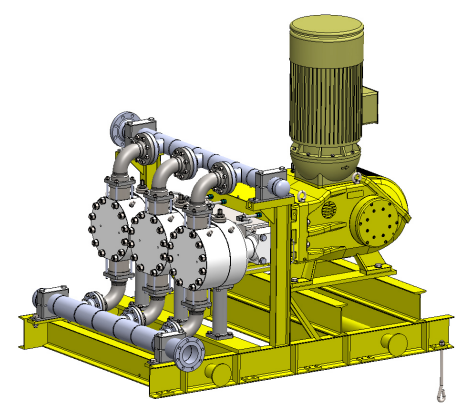

Application: Chemicals
 Fluid: PH=2~5 Acid water
 Temp: 140° F / 60° C
 Capacity: 141 gph / 32 m³/h
 Pressure: 696 psig / 48 barg
 Motor Power: 75kW



PUMP SUPPLY
 INCORPORATED



MN - (651) 758-7867

Features

Critical Sub-Assembly

Provides Operating Efficiencies and Savings

Features and Benefits

- Wear-resistant copper alloy worm gear, runs efficiently and provides a long service life.
- Moving parts lubricated in oil bath to reduce wear.
- Connecting rods with standard bearing for convenient maintenance.
- Unique cross-head seal structure protects against leakage.
- Forged alloy steel crankshaft ensures reliable performance and a long product life.
- Advanced bearing configuration, maintains a smooth and predictable movement of the suction and discharge.



Unique 3-headed Liquid-End

Achieves high discharge pressures to 3,655 psig / 252 bar

Features and Benefits

- Leak-resistant design protects the process and the environment from dangerous and costly contamination.
- Patented diaphragm design with service life over 20,000 hours reduces maintenance costs while protecting against leakages.
- Integrated air-bleed valve for accurate “control” of flow.
- Patented MARS refill system automatically controls the hydraulic oil to protect the diaphragm from rupture while increasing the overall pump reliability and reducing maintenance time and expense.
- Equipped with a double-diaphragm detection system to monitor via local or remote alarm in the unlikely event of a rupture.

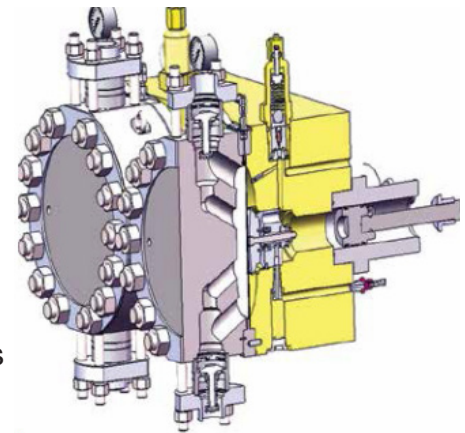

Multiple Options Available

The MEGAROYAL pump offers a variety of options to customize the pump to meet specific application requirements. Contact the factory for details.

Features & Benefits

- Specially designed suction and discharge valves for the greatest pump efficiency.
- Consistent performance in low and high temperatures.
- Jacket insulation provides added protection.
- Specific design to handle difficult to pump slurry applications with ease.
- Choose from a variety of liquid end materials to meet your specific application requirements.
- Built with corrosion-resistant materials to withstand the harshest environments and applications.

Dimensions

HX268	
in.	79.3 × 68.9 × 99.6
mm	2015 × 1750 2530

HX308	
in.	106.8 × 75.2 × 99.6
mm	2715 × 1910 × 2530

HX368	
in.	115.4 × 83.9 × 99.6
mm	2930 × 2130 2530

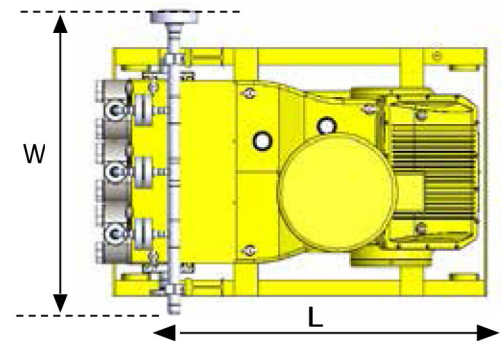
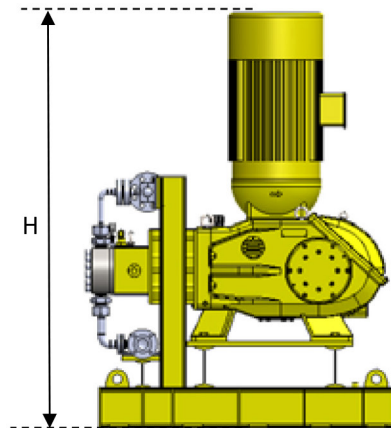

TYPE HX 268 - 50 and 60 Hz Motors

Plunger Diameter	50 Hz Motor				60 Hz Motor				Connections
	Stroke Speed Max.	Motor Speed Max.	Flow Rate Max. theoretical	Max. Pressure	Stroke Speed Max.	Motor Speed Max.	Flow Rate Max. theoretical	Max. Pressure	
Ø	spm	rpm	(L/h)	(bar)	spm	rpm	(gph)	(psi)	
55	146	1440	7492	252	140	1728	1979	3654	Inlet 4"-HH3, Outlet 3"-HH3
60	146	1440	8916	212	140	1728	2355	3074	Inlet 4"-HH3, Outlet 3"-HH3
63	146	1440	9830	192	140	1728	2596	2784	Inlet 4"-HH3, Outlet 3"-HH3
65	146	1440	10464	181	140	1728	2764	2622	Inlet 4"-HH3, Outlet 3"-HH3
70	146	1440	12136	155	140	1728	3206	2248	Inlet 4"-HH3, Outlet 3"-HH3
75	146	1440	13932	135	140	1728	3680	1958	Inlet 4"-HH3, Outlet 3"-HH3

TYPE HX 308 - 50 and 60 Hz Motors

Plunger Diameter	50 Hz Motor				60 Hz Motor				Connections
	Stroke Speed Max.	Motor Speed Max.	Flow Rate Max. theoretical	Max. Pressure	Stroke Speed Max.	Motor Speed Max.	Flow Rate Max. theoretical	Max. Pressure	
Ø	spm	rpm	(L/h)	(bar)	spm	rpm	(gph)	(psi)	
80	146	1440	15851	119	140	1728	4187	1725	Inlet 5"-HH3, Outlet 4"-HH3
85	146	1440	17895	105	140	1728	4727	1522	Inlet 5"-HH3, Outlet 4"-HH3
90	146	1440	20062	94	140	1728	5299	1363	Inlet 5"-HH3, Outlet 4"-HH3
95	146	1440	22353	84	140	1728	5905	1218	Inlet 5"-HH3, Outlet 4"-HH3
100	146	1440	24768	76	140	1728	6543	1102	Inlet 5"-HH3, Outlet 4"-HH3
105	146	1440	27307	69	140	1728	7213	1000	Inlet 5"-HH3, Outlet 4"-HH3

TYPE HX 368 - 50 and 60 Hz Motors

Plunger Diameter	50 Hz Motor				60 Hz Motor				Connections
	Stroke Speed Max.	Motor Speed Max.	Flow Rate Max. theoretical	Max. Pressure	Stroke Speed Max.	Motor Speed Max.	Flow Rate Max. theoretical	Max. Pressure	
Ø	spm	rpm	(L/h)	(bar)	spm	rpm	(gph)	(psi)	
110	146	1440	29969	63	140	1728	7917	913	Inlet 6"-HH3, Outlet 5"-HH3
115	146	1440	32756	57	140	1728	8653	826	Inlet 6"-HH3, Outlet 5"-HH3
120	146	1440	35666	53	140	1728	9422	768	Inlet 6"-HH3, Outlet 5"-HH3
125	146	1440	38700	48	140	1728	10223	696	Inlet 6"-HH3, Outlet 5"-HH3
130	146	1440	41858	45	140	1728	11057	652	Inlet 6"-HH3, Outlet 5"-HH3
135	146	1440	45140	41	140	1728	11924	594	Inlet 6"-HH3, Outlet 5"-HH3
140	146	1440	48545	39	140	1728	12824	565	Inlet 6"-HH3, Outlet 5"-HH3
145	146	1440	52075	36	140	1728	13756	522	Inlet 6"-HH3, Outlet 5"-HH3

Notes:

Illinois Location:
(847) 841-7867
860 Church Rd Elgin, IL 6

Minnesota Location
(651) 758-7867
330 Mill Bay South Suite
Afton, MN 55001



PumpSupplyInc.com

The complex block contains contact information for two locations and a logo. On the left, the Illinois location is listed with phone number (847) 841-7867 and address 860 Church Rd Elgin, IL 6. Below it, the Minnesota location is listed with phone number (651) 758-7867 and address 330 Mill Bay South Suite Afton, MN 55001. At the bottom left of this section is the website PumpSupplyInc.com. To the right is a map of the United States with stars marking the locations in Illinois and Minnesota. Below the map is the logo for Pump Supply Incorporated, which consists of a blue triangle containing the letters 'PS' in white, followed by the text 'PUMP SUPPLY' in a large, bold, sans-serif font, and 'INCORPORATED' in a smaller, spaced-out, sans-serif font below it.

About Ingersoll Rand Inc.

Ingersoll Rand Inc. (NYSE:IR), driven by an entrepreneurial spirit and ownership mindset, is dedicated to helping make life better for our employees, customers and communities. Customers lean on us for our technology-driven excellence in mission-critical flow creation and industrial solutions across 40+ respected brands where our products and services excel in the most complex and harsh conditions. Our employees develop customers for life through their daily commitment to expertise, productivity and efficiency. For more information, visit www.IRCO.com.



<p><u>Illinois Location:</u> (847) 841-7867 860 Church Rd Elgin, IL 6</p> <p><u>Minnesota Location</u> (651) 758-7867 330 Mill Bay South Suite Afton, MN 55001</p> <p>PumpSupplyInc.com</p>	  <p>PUMP SUPPLY INCORPORATED</p>
-------------------------------------------------------------------------------------------------------------------------------------------------------------------------------------------------------------------------------	------------------------------------------------------------------------------------------------------------------------------------------------------------------------------------------------------------------------

MEGARROYAL is a registered trademark of Milton Roy.

