

MacRoy[®] D Metering Pump

IOM Manual

Manual No. : 53872

Rev. : 01

Rev. Date : 05/2019





PRECAUTIONS

For Pumps with PVC & 316SS Liquid Ends WHEN USED IN SWIMMING POOLS OR SPAS / HOT TUBS (ANSI / NSF 50)

Caution on Chemical Concentration:



There is a potential for elevated chemical concentration during periods of no flow, for example, during backwash in the system. Steps, such as turning the pump off, should be taken during operation or installation to prevent this. Contact your sales representative or distributor about other external control options to help mitigate this risk.

Flow Indicating Device:



To ensure operation of the pump it is recommended that some type of flow indicating device be installed to measure water flow rates and be appropriate for the output of the pump. Contact your distributor or sales representative for further information.

Head Loss / Over Pressure Protection / Back Pressure-Anti-Siphon Valve:



- Milton Roy metering pumps are positive displacement. Head loss is not applicable to the pump.
- To ensure safe operation of the pump, it is recommended that some type of safety / pressure relief valve be installed to protect the piping and other system components from failing due to excessive pressure.
- If you are pumping downhill or into low or no system pressure, a back pressure / anti-siphon device should be installed to prevent over pumping or siphoning. Contact your distributor or sales representative for further information.

Additional Operation and Installation Instructions for 316SS or PVC Liquid Ends:



- Application of this pump to swimming pool / spas only evaluated to NSF / ANSI 50.
- There is a potential for elevated chemical concentration during periods of no flow, for example, during backwash in the system. Steps, such as turning the pump off, should be taken during operation or installation to prevent this. See your sales representative or distributor about other external control options to help mitigate this risk.
- Liquid Compatibility CAUTION: Determine if the materials of construction included in the liquid handling portion of your pump are adequate for the solution (chemical) to be pumped. ALWAYS wear protective clothing, face shield, safety glasses and gloves when working on or near your metering pump. Additional precautions should be taken depending on the solution being pumped. Refer to SDS precautions from your solution supplier. Reference a Milton Roy Material Selection Chart for aid in selecting appropriate material of construction for fluids of your specific metering pump. Contact your sales representative or distributor for further information.



GENEERAL PRECAUTIONS FOR ALL PUMPS

The following precautions should be taken when working with metering pumps. Please read this section carefully prior to installation.

Protective Clothing



ALWAYS wear protective clothing, face shield, safety glasses and gloves when working on or near your metering pump. Additional precautions should be taken depending on the solution being pumped. Refer to **Material Safety Data Sheets** for the solution being pumped.

Hearing Protection



It is recommended that hearing protection be used if the pump is in an environment where the timeweighted average sound level (TWA) of 85 decibels is exceeded. (as measured on the A scale slow response).

Electrical Safety



- Remove power and ensure that it remains off while maintaining pump.
- **DO NOT FORGET TO CONNECT THE PUMP TO EARTH.**
- Electric protection of the motor (Thermal protection or by means of fuses) is to correspond to the rated current indicated on the motor data plate.

Liquid Compatibility



Verify if the materials of construction of the wetted components of your pump are recommended for the solution (chemical) to be pumped.

Pumps Water "Primed"



All pumps are tested with water at the factory. If your process solution is not compatible with water, flush the **Pump Head Assembly** with an appropriate solution before introducing the process solution.

Plumbing and Electrical Connections



Always adhere to your local plumbing and electrical codes.

Line Depressurization



To reduce the risk of chemical contact during disassembly or maintenance, the suction and discharge lines should be depressurized before servicing.

Over Pressure Protection



To ensure safe operation of the system, it is recommended that some type of safety / pressure relief valve be installed to protect the piping and other system components from damage due to over-pressure.

Lifting



This manual should be used as a guide only - Follow your company's recommended lifting procedures. It is not intended to replace or take precedence over recommendations, policies and procedures judged as safe due to the local environment than what is contained herein. Use lifting equipment that is rated for the weight of the equipment to be lifted.



TABLE OF CONTENTS

1.0 DESCRIPTION 8

 1.1 GENERAL INFORMATION 8

 1.2 PRINCIPLE OF OPERATION 9

 1.3 GENERAL SPECIFICATIONS 10

2.0 INSTALLATION 11

 2.1 UNPACKING 11

 2.2 STORAGE 11

 2.3 SAFETY PRECAUTIONS 12

 2.4 MOUNTING 12

 2.5 DRIP COLLECTION 12

 2.6 INSTALLATION 15

 2.6.1 NPSH Considerations 15

 2.6.2 General Piping Considerations 15

 2.6.3 Suction Piping Considerations 16

 2.6.4 Discharge Piping Considerations 16

 2.7 VALVES 17

 2.7.1 Back Pressure Valves 17

 2.7.2 Pulsation Dampeners 17

 2.7.3 Shut-off Valves 17

 2.8 ELECTRICAL CONNECTIONS 17

3.0 OPERATION 18

 3.1 START-UP PROCEDURES AND CHECKS 18

 3.2 CHECKING THE ELECTRICAL CONNECTION OF THE MOTOR 18

 3.3 START-UP 18

 3.4 CAPACITY CALIBRATION 18

4.0 MAINTENANCE 19

 4.1 PREVENTATIVE MAINTENANCE 19

 4.2 RETURNING PUMPS TO THE FACTORY FOR REPAIR 19

 4.3 ROUTINE MAINTENANCE 19

 4.4 SPARE PARTS 21

 4.4.1 Size D2 Liquid Ends - PVC, PVDF, Polypropylene, Polymer and H₂SO₄ 22

 4.4.2 Size D2 Liquid Ends - PVC, PVDF, Polypropylene, Polymer, H₂SO₄ and Slurry 22

 4.4.3 Size D2 and D4 Liquid Ends - Stainless Steel 23

 4.4.4 Size D7 and D8 - PVC, PVDF, Polypropylene, H₂SO₄, Polymer and Slurry Liquid Ends 23

 4.4.5 Size D7 and D8 - Stainless Steel Liquid Ends 24

 4.5 CORRECTIVE MAINTENANCE 24

 4.5.1 Check Valve Replacement: Liquid Ends D2 and D4 - PVC, PVDF, H₂SO₄ and Polypropylene 25

 4.5.2 Check Valve Replacement: Liquid End Sizes D2 and D4 - Polymer 25

 4.5.3 Check Valve Replacement: Liquid End Sizes D2 and D4 - Metallic 26

 4.5.4 Check Valve Replacement: Liquid End Sizes D2 and D4 - Slurry 26

 4.5.5 Replacement of Ball, Seat and Seal: Liquid End D7 and D8 - PVC, PVDF, H₂SO₄ and Polypropylene 26

4.5.6 Check Valve Replacement: Liquid End Size D7 and D8 - Polymer 28

4.5.7 Check Valve Replacement: Liquid End Size D7 and D8 - Slurry 28

4.5.8 Check Valve Replacement: Liquid End Size D7 and D8 - Stainless Steel 28

4.6 DIAPHRAGM AND OIL SEAL BELLOWS REPLACEMENT 29

4.6.1 Diaphragm Replacement: Liquid End Size D2 29

4.6.2 Diaphragm Replacement: Liquid End Size D4, D7 and D8 30

4.7 OIL SEAL BELLOWS REPLACEMENT. 31

4.8 RESTARTING THE PUMP. 32

5.0 PARTS LIST 33

5.1 PARTS LIST FOR DRIVE 38

5.2 PARTS LIST FOR D2 PLASTIC LIQUID END PVC, PVDF, BLACK POLY, H₂SO₄ AND
POLYMER-NPT / PVC, PVDF AND BLACK POLY-TUBING 40

5.3 PARTS LIST FOR D2 METALLIC LIQUID END STAINLESS STEEL-NPT 36

5.4 PARTS LIST FOR D4 METALLIC LIQUID END STAINLESS STEEL-NPT 42

5.5 PARTS LIST FOR D4 PLASTIC LIQUID END PVC, PVDF, BLACK POLY, H₂SO₄, SLURRY AND
POLYMER- NPT / PVC, PVDF, BLACK POLY AND H₂SO₄-TUBING. 44

5.6 PARTS LIST FOR D7 AND D8 PLASTIC LIQUID END PVC-NPT / TUBING, PVDF-NPT, BLACK
POLY-NPT, POLYMER-NPT, SLURRY-NPT & H₂SO₄-NPT 48

5.7 PARTS LIST FOR D7 AND D8 316SS-NPT LIQUID END. 52

5.8 LEAK DETECTION PARTS LIST. 55

6.0 TROUBLESHOOTING 58

LIST OF ILLUSTRATIONS

FIGURE 1. Pump Assembly 8

FIGURE 2. Stroke Control Operating Principle 9

FIGURE 3. MacRoy® D Dimensional Outline 13

FIGURE 4. Typical Installation 14

FIGURE 5. General Piping 15

FIGURE 6. Drive Assembly. 20

FIGURE 7. Diaphragm Assemblies By Liquid End Size and Material 21

FIGURE 8. Drive Assembly. 34

FIGURE 9. D2 Plastic Liquid End 37

FIGURE 10. D2 Metallic Liquid End 40

FIGURE 11. D4 Metallic Liquid End 41

FIGURE 12. D4 Plastic Liquid End 43

FIGURE 13. D7 & D8 Plastic Liquid End 47

FIGURE 14. D7 & D8 316SS Liquid End 51

FIGURE 15. Leak Detection Switch and / or Gauge (Optional) 53

FIGURE 16. Double Diaphragm, D4 Pressure Type Configured (Optional) 54

FIGURE 17. Double Diaphragm, D7 & D8 Pressure Type Configured (Optional) 54





MACROY® D PUMP MODEL NUMBER AND OPTIONS

Frame and Liquid End	Stroking Speed	Motor	Liquid End Material	Connections	Capacity Control	Double Diaphragm	Base	Stroke Counting
□ □	□	□	□	□	□ □	□	□	□

Frame and Liquid End (D Frame)	
Code	Description
D2	0.3 mL/stroke
D4	4.4 mL/stroke
D7	18 mL/stroke
D8	42 mL/stroke
Stroking Speed	
Code	Description
1	43 SPM
2	86 SPM
6	120 SPM
3	173 SPM
8	180 SPM @1450 RPM
Motor	
Code	Description
X	NEMA 56C Mount Less Motor
8	115/230 VAC, 60 Hz, 1 PH, 1725 RPM
9	115/230 VAC, 50 Hz, 1 PH, 1450 RPM
J	230/460 VAC, 60 Hz, 3 PH, 1725 RPM
L	220/380 VAC, 50 Hz, 3 PH, 1450 RPM
M	IEC 71 Frame F130 Less Motor
P	DC VSD & Motor
Liquid End Material	
Code	Description
2	PVDF
4	Black Polypropylene (UV Stable)
7	316SS
8	PVC
P	Polymer Service
L	Slurry Applications
N	H2SO4 Applications
A	Acrylic

Connections	
Code	Description
P	NPT
T	Tubing
B	Outgassing Liquid Applications (NPT)
C	Outgassing Liquid Applications (Tubing)
Capacity Control	
Code	Description
M4	Manual
E1	4-20ma, NEMA 4 115 VAC
E2	4-20ma, NEMA 4 230 VAC
EA	4-20ma, Ex Prf 115 VAC
EB	4-20ma, Ex Prf 230 VAC
Double Diaphragm	
Code	Description
N	None
D	Double Diaphragm
3	Double Diaphragm w/Gauge
4	Double Diaphragm w/NEMA 4 Rupture Detection
7	Double Diaphragm w/NEMA 7 Rupture Detection

Base	
Code	Description
N	None
1	Simplex Optional Base

Stroke Counting	
Code	Description
N	None



MacRoy® D Capacity / Pressure

English Units

Liquid End Codes	SPM @		GPH @ Max PSI		Max PSI
	60 Hz	50 Hz	60 Hz	50 Hz	
2	43	36	0.18	0.15	175
	86	72	0.35	0.29	
	120	102	0.48	0.40	
	173	144	0.7	0.58	
4	43	36	3.0	2.5	150
	86	72	6.6	5.5	
	120	102	10	6.9	
	173	144	12	12	
7	43	36	13	10	100
	86	72	25	21	
	120	102	34	28	
	173	144	50	42	
8	43	36	31	26	75
	86	72	57	47	
	120	102	87	72	
	173	144	127	106	

Metric Units

Liquid End Codes	SPM @		GPH @ Max Bar		Max Bar
	60 Hz	50 Hz	60 Hz	50 Hz	
2	43	36	0.7	0.6	12
	86	72	1.3	1.1	
	120	102	1.8	1.5	
	173	144	2.6	2.2	
4	43	36	11.4	9.5	10
	86	72	25	21	
	120	102	38	26	
	173	144	45	45	
7	43	36	49	38	7
	86	72	95	79	
	120	102	129	106	
	173	144	189	159	
8	43	36	117	98	5
	86	72	216	178	
	120	102	329	273	
	173	144	481	401	

NOTE:

1. All Capacities are based on maximum pressure. For operation at reduced pressures, add 1% flow for every 25 psi (1.7 bar) decreased in pressure.
2. Motor requirements: 1/4 Horsepower or 0.25KW

Illinois Location:
 (847) 841-7867
 860 Church Rd Elgin, IL 60

Minnesota Location:
 (651) 758-7867
 330 Mill Bay South Suite 1
 Afton, MN 55001

PumpSupplyInc.com

SECTION 1 - DESCRIPTION

1.1 GENERAL INFORMATION

The MacRoy® D is a reciprocating, chemical dosing pump capable of producing flows up to 115 gph (430 liters per hour) at pressures up to 175 psi (12 bar). These pumps feature a mechanically actuated diaphragm liquid end, which eliminates the need for flow-restricting contour plates, and a stroke adjustment mechanism based on the variable eccentric principle instead of the traditional lost-motion design. It is designed for industrial service and offers an accuracy of $\pm 1\%$ of full rated flow between 10% and 100% of its flow range.

The basic pump components as illustrated in *Figure 1* are:

- a drive device comprising a motor (1).
- a mechanical assembly (2).
- a liquid end (3).

An elastomeric bellows provides a leak-tight seal between the mechanical assembly and the liquid end.

Capacity adjustment is manually controlled by a stroke adjustment knob (4).

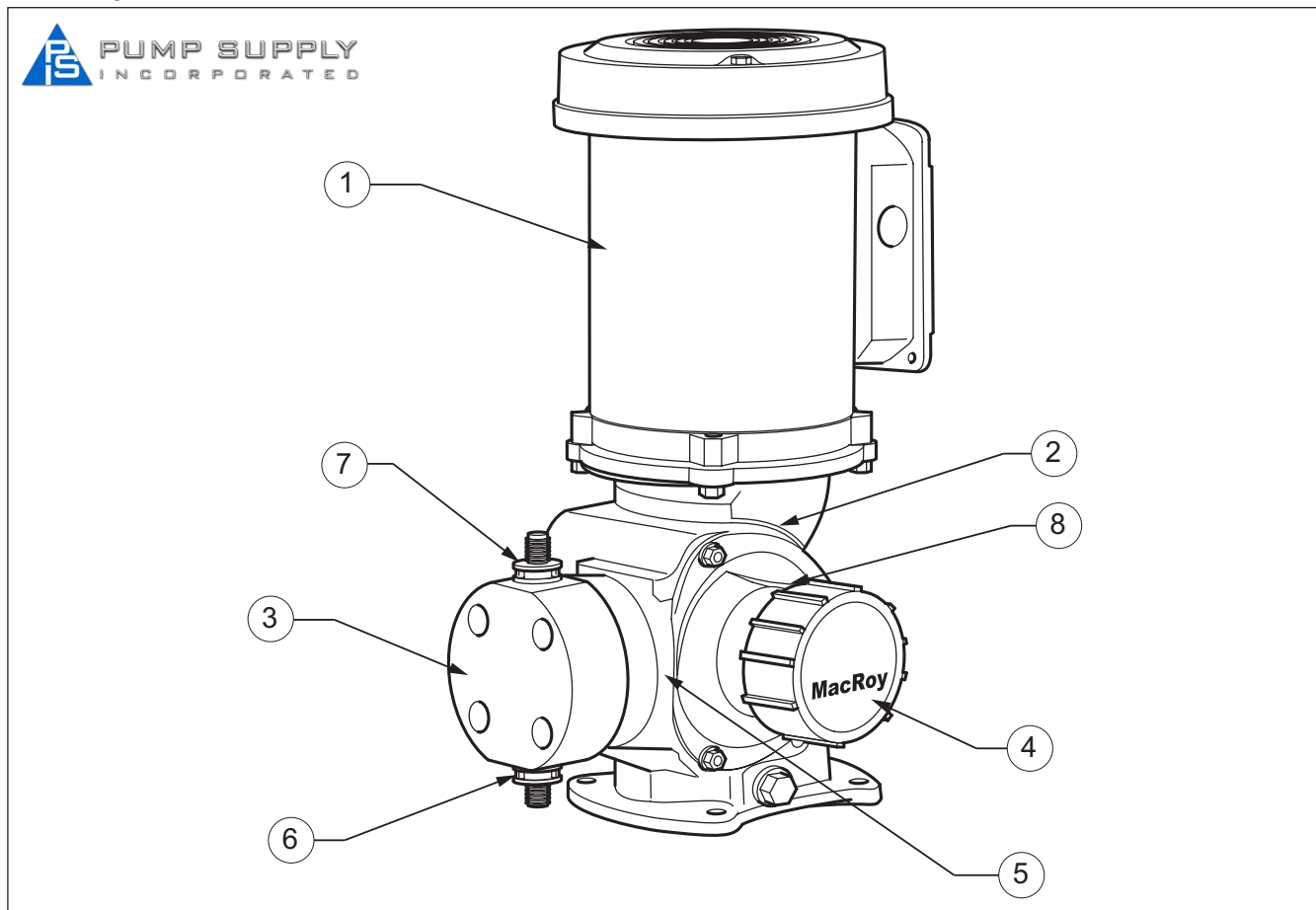

Figure 1. Pump Assembly

1	Motor	5	Liquid End Mounting Assembly
2	Mechanical Assembly	6	Check Valve Assembly (Suction)
3	Liquid End	7	Check Valve Assembly (Discharge)
4	Stroke Adjustment Knob	8	Stroke Lock Knob

SECTION 1 - DESCRIPTION

1.2 PRINCIPLE OF OPERATION

Drive Assembly (See Figure 2)

The pump consists of two major assemblies; the drive and the liquid end. Pump delivery is a function of the drive's stroke rate, liquid end size and stroke length. Stroke length can be increased while the pump is running by counterclockwise turning of the stroke adjustment knob. The drive assembly works on the principle of a variable eccentric. The rotational motion of the motor is transmitted by the worm (1) to the worm gear (2) which is linked to an eccentric system (3). The eccentric system then converts the rotary gear motion into linear reciprocating motion of the connecting rod (4).

At 0% capacity setting, the connecting rod axis (B) is aligned with the gear axis (A) and no movement of the connecting rod takes place. At 100% capacity setting, an eccentricity exists between the connecting rod axis (B) and the gear axis (A) which results in linear movement of the connecting rod and resulting pumpage.

Drive parts (See Figure 8 for limited drive parts available) are no longer sold by Milton Roy. When drive parts are found to be bad a complete new painted pump body with all gears, stroke controls etc. can be purchased from Milton Roy. The customer will only need to mount the liquid end motor from the existing pump.

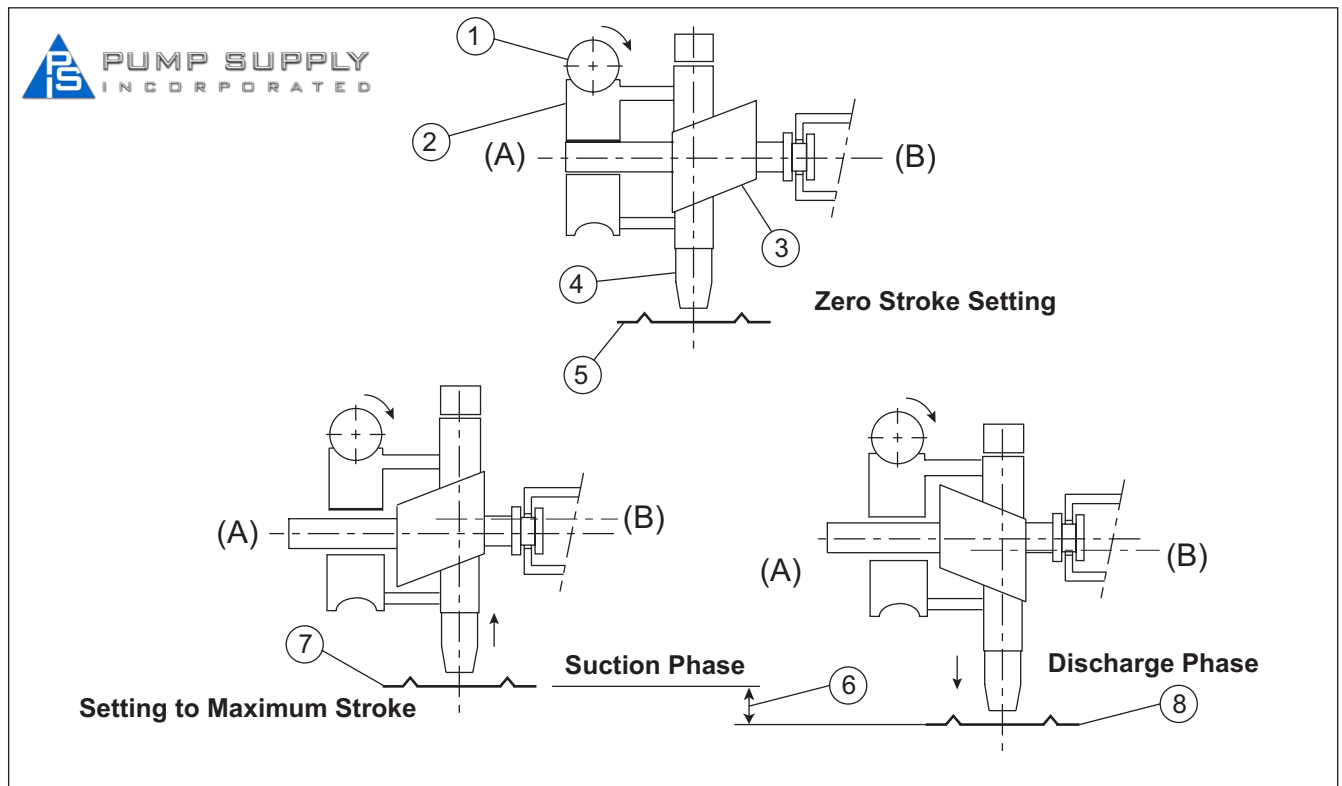

Figure 2. Stroke Control Operating Principle

1	Worm	5	Diaphragm
2	Worm Gear	6	Stroke: two times the distance between (A) and (B)
3	Eccentric	7	Position at rear neutral point
4	Connecting Rod	8	Position at forward neutral point



SECTION 1 - DESCRIPTION

Mechanically-Actuated Diaphragm Liquid End (See Figure 2)

The diaphragm assembly (5) is mechanically linked to the connecting rod (4) and has the same reciprocating motion. As the diaphragm starts back on the suction stroke, the pressure immediately drops inside the liquid end. When the pressure in the liquid end drops below the suction line pressure, the suction ball check is “pushed” upward and the process fluid in the suction line flows into the liquid end chamber (diaphragm head). When the suction stroke ends, the diaphragm movement momentarily stops and the pressure in the liquid end equalizes with the pressure in the suction line causing the suction ball check to reseal.

NOTE:

It is important that the pressure in the liquid end remain above the vapour pressure of the process fluid during the suction stroke. If the fluid pressure drops below the vapour pressure, cavitation will occur which will have a negative impact on the performance of the pump. If you suspect the possibility of cavitation, contact Milton Roy for assistance.

As the diaphragm starts forward on the discharge stroke the pressure immediately rises inside the liquid end. When the liquid end pressure rises above the discharge line pressure, the discharge ball check is “pushed” upward and the process fluid in the liquid end flows into the discharge line. When the discharge stroke ends, the diaphragm momentarily stops again. The pressure in the liquid end equalizes with the discharge line pressure and the discharge ball check reseats. The cycle then starts again.

1.3 GENERAL SPECIFICATIONS

Flow Rate	Up to 115 GPH (430 L/H)
Pressure	Up to 175 PSIG (12 BAR)
Liquid End Type	Mechanically-Actuated Diaphragm
Drive Type	Variable Eccentric
Steady State Accuracy	±1% of pump full rated capacity between 10% and 100% of rated capacity.
Capacity Adjustment	Lockable stroke adjustment knob is adjustable from 0% to 100% while pump is running.
Lubrication	Drive is lubricated in an oil bath (Mobil SHC 629, 1 Quart).
Temperature	
Ambient and Liquid:	122° F (50°C) Maximum
	14° F (-10°C) Minimum
Suction Lift	6.6 Ft (2 meters) of water column maximum
	11.5 psia minimum internal pressure (3.2 psi maximum vacuum)
Paint	Powder Coating
Weight	38 lb (17.2 kg) Without EEC
	48 lb (21.8 kg) With EEC

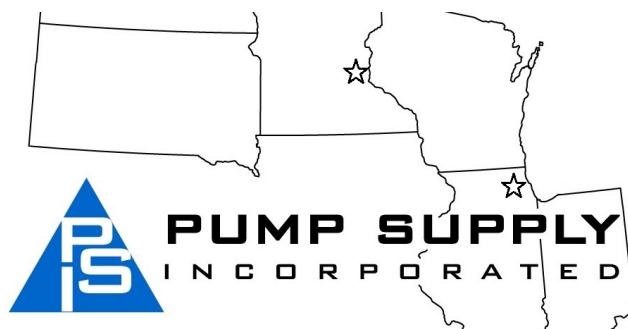

SECTION 2 - INSTALLATION

2.1 UNPACKING

Pumps are shipped Free on Board factory (FOB) or representative warehouse and the title passes to the customer when the carrier signs for receipt of the pump. In the event that damages occur during shipment, it is the responsibility of the customer to notify the carrier immediately and to file a damage claim. Carefully examine the shipping crate upon receipt from the carrier to be sure there is no obvious damage to the contents. Open the crate carefully so accessory items fastened to the inside of the crate will not be damaged or lost. Examine all material inside the crate and check against packing list to be sure that all items are accounted for and intact.

2.2 STORAGE

Short Term Storage (Less than 6 Months)

It is preferable to store the material under a shelter in its original package to protect it from adverse weather conditions. In condensing atmospheres, follow the long term storage procedure.

Long Term Storage (Longer than 6 Months)

The primary consideration in storage of pump equipment is to prevent corrosion of external and internal components. This corrosion is caused by natural circulation of air as temperature of the surroundings change from day to night, day to day, and from season to season. It is not practical to prevent this circulation which carries water vapour and other corrosive gasses, so it is necessary to protect internal and external surfaces from their effects to the greatest extent possible.

When the instructions given in this section are completed, the equipment is to be stored in a shelter; protected from direct exposure to weather. The prepared equipment should be covered with a plastic sheet or a tarpaulin, but in a manner which will allow air circulation and prevent capture of moisture. Equipment should be stored 12 inches or more above the ground.

If equipment is to be shipped directly from Milton Roy into long term storage, contact Milton Roy to arrange for factory preparation.

Pump Drive

1. Remove motor and flood the gearbox compartment (Item 2 in *Figure 1*) with a high grade lubricating oil / rust preventative such as Mobile Oil Corporation product Mobilarma 524. Fill the compartment completely to minimize air space and water vapour condensation. After storage, drain this material and refill the equipment with the recommended lubricant for equipment commissioning.
2. Brush all unpainted metal surfaces with multipurpose grease (NLGI grade 2 or 3). Store these unattached.

Electrical Equipment

1. Motors should be prepared in the manner prescribed by their manufacturer. If information is not available, dismount and store motors as indicated in step 3 below.
2. Dismount electrical equipment (including motors) from the pump.
3. For all electrical equipment, place packets of Vapour Phase Corrosion Inhibitor (VPCI) inside of the enclosure, then place the entire enclosure, with additional packets, inside a plastic bag. Seal the bag tightly closed. Contact Milton Roy Service Department for recommended VPCI materials.



SECTION 2 - INSTALLATION

2.3 SAFETY PRECAUTIONS

CAUTION WHEN INSTALLING, OPERATING, AND MAINTAINING THIS MACROY® D PUMP, KEEP SAFETY CONSIDERATIONS FOREMOST. USE PROPER TOOLS, PROTECTIVE CLOTHING, AND EYE PROTECTION WHEN WORKING ON THE EQUIPMENT AND INSTALL THE EQUIPMENT WITH A VIEW TOWARD ENSURING SAFE OPERATION. FOLLOW THE INSTRUCTIONS IN THIS MANUAL AND TAKE ADDITIONAL SAFETY MEASURES APPROPRIATE TO THE LIQUID BEING PUMPED. BE EXTREMELY CAREFUL IN THE PRESENCE OF HAZARDOUS SUBSTANCES (E.G., CORROSIVES, TOXINS, SOLVENTS, ACIDS, CAUSTICS, FLAMMABLES ETC).

CAUTION THE PERSONNEL RESPONSIBLE FOR INSTALLATION, OPERATION AND MAINTENANCE OF THIS EQUIPMENT MUST BECOME FULLY ACQUAINTED WITH THE CONTENTS OF THIS MANUAL. ANY SERVICING OF THIS EQUIPMENT MUST BE CARRIED OUT WHEN THE UNIT IS STOPPED AND ALL PRESSURE HAS BEEN BLED FROM THE LIQUID END. SHUT-OFF VALVES IN SUCTION AND DISCHARGE SIDES OF THE LIQUID END SHOULD BE CLOSED WHILE THE UNIT IS BEING SERVICED. ACTIONS SHOULD BE TAKEN TO ELIMINATE THE POSSIBILITY OF ACCIDENTAL START-UP WHILE SERVICING IS TAKING PLACE. A NOTICE SHOULD BE POSTED BY THE POWER SWITCH TO WARN THAT SERVICING IS BEING CARRIED OUT ON THE EQUIPMENT. SWITCH OFF THE POWER SUPPLY AS SOON AS ANY FAULT IS DETECTED DURING OPERATION (EXAMPLES: ABNORMALLY HIGH DRIVE TEMPERATURE, UNUSUAL NOISE AND DIAPHRAGM FAILURE).

2.4 MOUNTING

Support the pump firmly in a level position on a solid, vibration-free foundation. The pump should preferably be positioned with the base above floor level to protect the pump from wash downs and to provide easier access for service. Be sure to allow enough space around the pump for easy access during maintenance operations and pump adjustments. MacRoy® D pumps are provided with mounting holes to accommodate anchor bolts. *Refer to Figure 3 for mounting hole dimensions.* Pumps installed outdoors should be protected by a shelter.

2.5 DRIP COLLECTION

In the event of a failure of the diaphragm or oil seal bellows, provisions need to be made to contain the process fluid or pump oil. This is particularly important when handling fluids which may be harmful to plant personnel. To collect fluid in the event of a diaphragm or oil seal rupture, (See *Figure 1*) position a tray under the plain hole located at the bottom of the liquid end mounting assembly (5). For D7 or D8 pumps, position tray under tube fitting located at bottom of liquid end mounting assembly. Alternatively, a tube may be installed onto this tube fitting to drain any leakage to a suitable container.



Illinois Location:

(847) 841-7867

860 Church Rd Elgin, IL 60123

Minnesota Location:

(651) 758-7867

330 Mill Bay South Suite 1511 Afton, MN 55001

PumpSupplyInc.com



LE Size	CONN.	A	B	C
D2	PLASTIC-NPT(1/4" M)	5.53	4.5	10.5
D2	PLASTIC-TUBE(1/4")	7.53	4.5	10.5
D2	METALLIC-NPT(1/4" M)	6.50	4.5	10.5
D4	PLASTIC-TUBE(1/2")	7.53	4.5	10.5
D4	PLASTIC-NPT(1/4" M)	5.53	4.5	10.5
D4	METALLIC-NPT(1/2" M)	6.80	4.5	10.5
D7/8	PLASTIC-NPT(1/2" F)	9.94	6.2	13.0
D7/8	METALLIC-NPT(1/2" F)	10.25	6.2	13.0

M = Male; F = Female All dimensions in inches.
 Shown with standard 1/4 HP, TEFC, NEMA 56 Motor

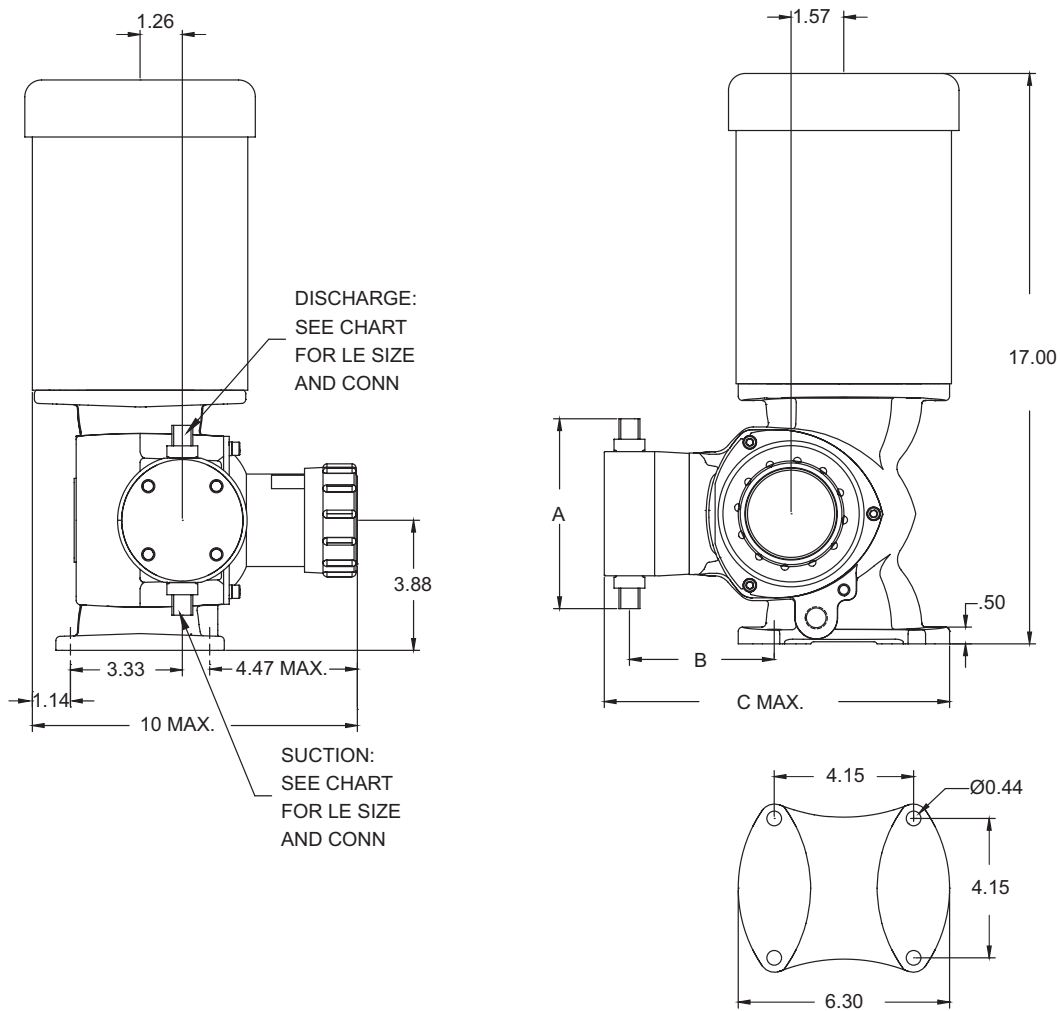

Figure 3. MacRoy® D Dimensional Outline (1022784000)

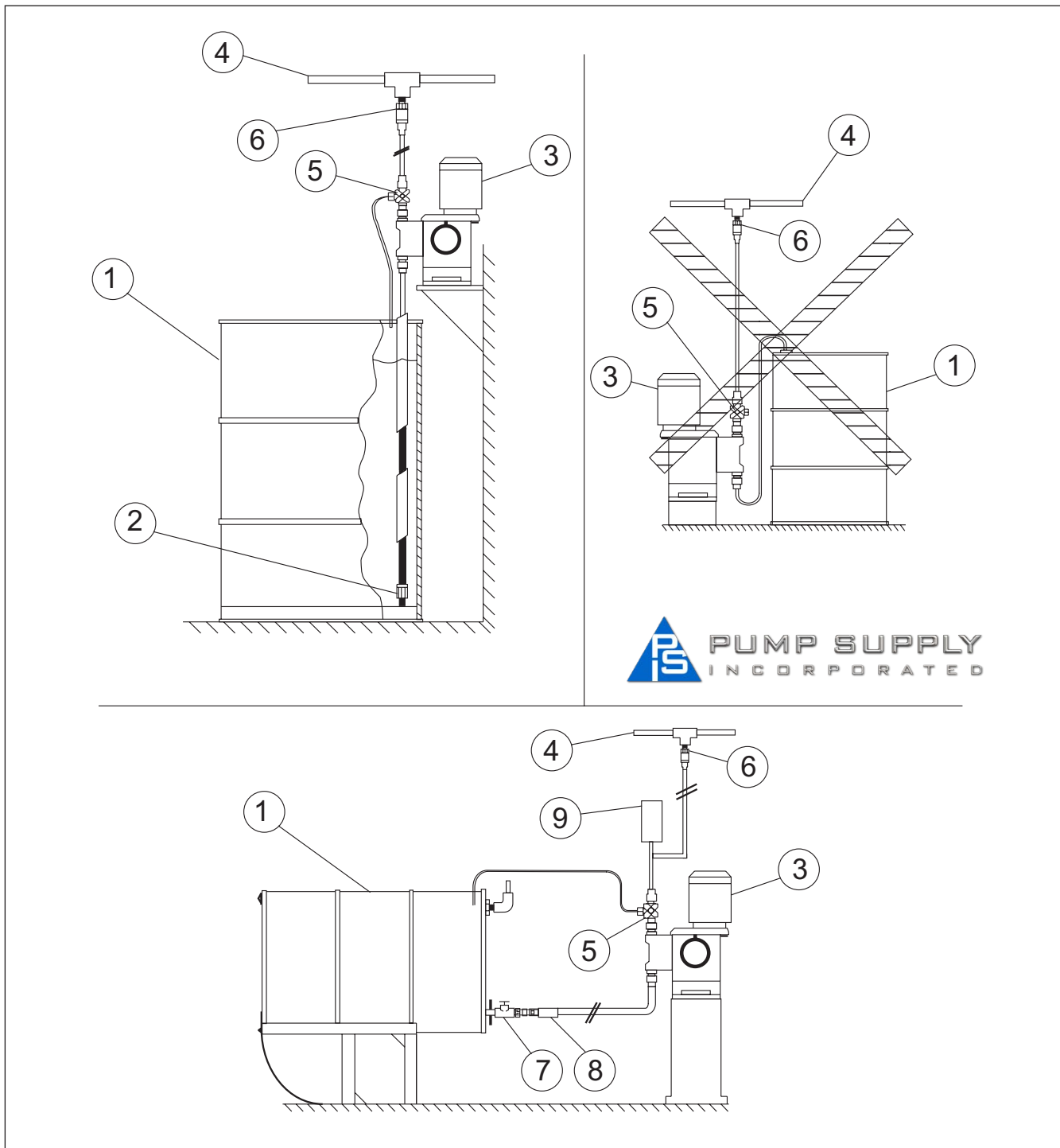

Figure 4. Typical Installation

1	Tank	5	Injection Nozzle
2	Foot Valve (with Filter)	6	Shut-off Valve
3	Metering Pump	7	Filter
4	Process Piping	8	Pulsation Damper
5	Bleed Valve	-	-

SECTION 2 - INSTALLATION

2.6 INSTALLATION

Figure 4 displays typical installations (both correct and incorrect). *Figure 5* illustrates the recommended piping and accessories in a metering pump installation.

As illustrated in the upper right portion of *Figure 4*, there must be no swan-necks or stagnant volumes in the suction line. In this illustration, the loop at the top of the tank forms an air trap. Eventually, air or gases will bubble out of solution and accumulate in the trap leading to a loss of prime condition.

2.6.1 NPSH Considerations

Size piping to accommodate peak instantaneous flow. Because of the reciprocating motion of the pump diaphragm, peak instantaneous flow is approximately equal to 5 times the average flow. For example, a pump rated for 16 gph (61 L/hr.) requires piping sufficient for 5 x 16 gph, or 80 gph (303 L/hr.).

To minimize viscous flow losses when handling viscous liquids, it may be necessary to use suction piping up to four times larger than the size of the suction connection on the pump. If in doubt, contact your nearest Milton Roy representative to determine the necessary pipe size.

2.6.2 General Piping Considerations

Use extreme care in piping to plastic liquid end pumps with rigid pipe such as PVC. If excessive pipe stress or vibration is unavoidable, flexible connections are recommended.

Use piping materials that will resist corrosion by the liquid being pumped. Use care in selecting materials to avoid galvanic corrosion at pump liquid end connections.

Use piping heavy enough to withstand maximum pressures. Remove burrs, sharp edges, and debris from inside piping. Blow out all pipelines before making final connections to pump.

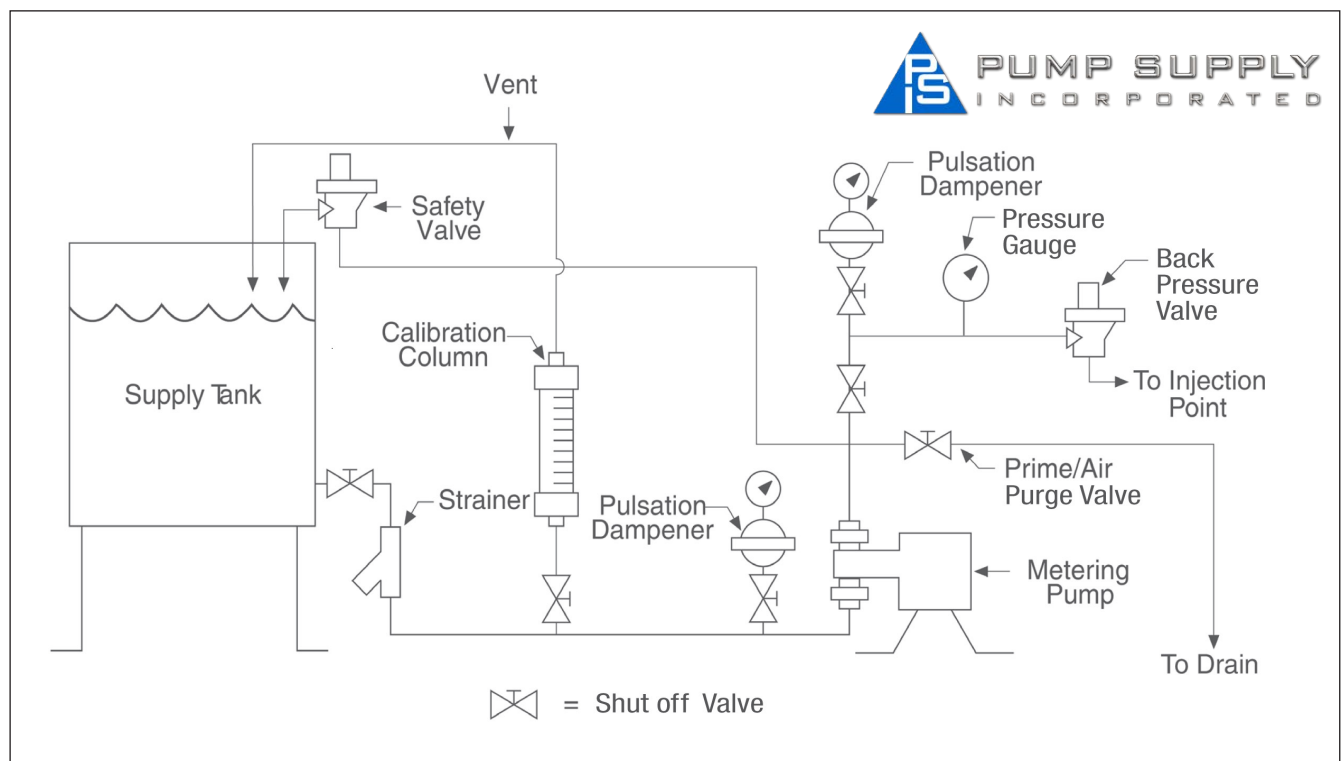

Figure 5. General Piping

SECTION 2 - INSTALLATION

Because vapour in the liquid end will cause inaccurate pump delivery, piping should be sloped up from pump suction check to the supply tank to prevent formation of vapour pockets.

When pumping suspended solids (such as slurries), install plugged crosses at all 90° line turns to permit line cleaning without dismantling piping.

See *Figure 5* for a typical recommended pump installation scheme.

2.6.3 Suction Piping Considerations

It is preferable to have the suction of the pump flooded by locating the liquid end below the lowest level of the liquid in the supply tank.

To minimize the chances of a loss-of-prime condition, the pump should be installed as close as possible to the supply vessel.

Avoid negative suction pressure conditions (suction lift), as such conditions adversely affect metering accuracy. A lift of 6.6 feet (2 meters) of water column is the maximum permissible suction lift.

MacRoy® D pumps are designed to operate with process liquid supplied at or above atmospheric pressure. Although these pumps can move liquids supplied at less than atmospheric pressure (suction lift), in these negative pressure applications, it is important that all connections be absolutely drip free and vacuum tight, and that a foot valve be installed at the bottom of the suction line (*see upper left illustration of Figure 4*).

When pumping a liquid near its boiling point, provide enough suction head to prevent the liquid from “flashing” into vapour when it enters the pump liquid end on the suction stroke.

If possible, use metal or plastic tubing for the suction line because tubing has a smooth inner surface and can be formed into long, sweeping bends to minimize frictional flow losses.

A strainer should be used in the suction line to prevent foreign particles from entering the liquid end. This and any other measures which prevent debris from entering and fouling the liquid end check valves will give increased maintenance free service. Check strainer frequently to prevent blockage which could lead to cavitation. Keep suction piping as short and straight as possible.

Piping size should be larger than the liquid end suction fitting to prevent pump starvation.

If long suction lines are unavoidable, install a stand pipe near the pump in the suction line.

Suction piping must be absolutely airtight to ensure accurate pumping. After installation, test suction piping for leaks with air and soap solution.

2.6.4 Discharge Piping Considerations

Install pipe large enough to prevent excessive pressure losses on the discharge stroke of the pump. Maximum pressure at the discharge fitting on the liquid end must be kept at or below the rated pressure (shown on the pump nameplate).

The pump will not deliver a controlled flow unless the discharge line pressure is 10 psi (0.7 bar) greater than the suction line pressure. One way to create an artificial pressure is the installation of a back pressure valve. (Please contact your Milton Roy representative for recommendations to increase back pressure in slurry applications).

When pumping water treatment chemicals directly into boiler drums, use one liquid end assembly for each boiler drum. Discharging into a manifold having the slightest pressure difference between its several discharge connections can diminish metering accuracy as the outlet with the lowest pressure will receive more liquid than the other outlets.

SECTION 2 - INSTALLATION

2.7 VALVES

2.7.1 Back Pressure Valves

All metering pumps are prone to overpumping (excessive output) at low discharge pressures. To prevent this condition from occurring, it is necessary to maintain approximately 10 psi (0.7 bar) back pressure against the pump. This can be accomplished through the installation of a back pressure valve in the discharge line. Typically, the valve should be located near the pump. However, back pressure valves for large pumps with long and extremely small discharge lines may have to be installed near the point of discharge into the process (to minimize siphoning tendencies).

2.7.2 Pulsation Dampeners

An accumulator, surge chamber, surge suppressor or pulsation dampener should be used with the back pressure valve in the discharge line to absorb the flow peaks between the pump and the back pressure valve. Without the pulsation dampener the valve mechanism will snap open and close with the surge from each pump stroke. The pulsation dampener will allow the back pressure valve to oscillate about a partly-closed position, thus minimizing wear on the valve. Discharge line pulsation dampeners offer the further advantage of limiting the flow and pressure variations characteristic of this kind of pump. Installing a properly sized pulsation dampener will improve pump performance and may reduce system costs dramatically by permitting the substitution of smaller piping. Please contact Milton Roy for further information on pulsation dampeners.

2.7.3 Safety Valves and Priming Valves

Motor-driven positive displacement pumps can develop excessive discharge pressures long before thermal overload devices interrupt the motor electrical circuit. To prevent a blocked discharge line from causing damage to the pump, piping or process equipment, install a safety valve in the pump discharge line. This valve is designed and sized to handle system flow rates and pressures safely while resisting corrosion by the process liquid.

To aid in pump start-up, it is advisable to install a priming valve on the discharge side of the liquid end.

2.7.4 Shut-off Valves

Provide shut-off valves in both suction and discharge lines next to the pump. Locate discharge line shut-off valve downstream from the inlet connection of the safety valve. *Figure 5 shows recommended valve locations.*

2.8 ELECTRICAL CONNECTIONS

⚠ CAUTION OPERATION WITH THE WRONG MOTOR ROTATION MAY DAMAGE THE PUMP AND MOTOR AND VOID THE WARRANTY. DO NOT FORGET TO CONNECT THE EARTH TERMINAL ON THE MOTOR TO THE EQUIPMENT EARTH CONDUCTOR.

Ensure that the electrical supply matches the pump motor nameplate characteristics. Connect the motor in accordance with the instructions and connection diagrams on the motor (or in the motor terminal box).

NOTE:

Before operating the pump, check the direction of rotation of the motor to be sure it matches the direction of the arrow on the motor fan cover (rotation should be clockwise when viewed from the top of the motor).

The electrical protection installed for the motor (fuse or thermal protection) must be suitable for the motor's rated current.

SECTION 3 - OPERATION

3.1 START-UP PROCEDURES AND CHECKS

Check that the pump is secured to its support. If oil was previously removed for any reason, make sure pump drive has the correct volume (1 quart) of oil (Mobil SHC 629).

Make sure all isolation valves installed on the suction and discharge lines are open. If the discharge line is equipped with an injection nozzle or a back-pressure valve, open the priming valve for discharge (if there is no priming valve, disconnect the discharge pipe). This allows for verification that liquid is present in the liquid end when the pump is installed in flooded suction condition. If the pump is installed in a suction lift condition, this allows for priming of the pump during start-up.

Make sure that pump is set at 0% capacity.

3.2 CHECKING THE ELECTRICAL CONNECTION OF THE MOTOR

Start up the pump to check the motor's direction of rotation. It must comply with that indicated by the arrow marked on the motor fan cover (clockwise as viewed from the top of the motor). If the rotation is incorrect, *refer to Section 2.8 Electrical Connections*.

3.3 START-UP

⚠ WARNING FAILURE TO CHECK TORQUE ON NON-METALLIC HEAD BOLTS PRIOR TO STARTUP AND AFTER ONE WEEK OF OPERATION MAY EXPOSE OPERATING PERSONNEL TO HAZARDOUS LIQUIDS.

Check the torque on all non-metallic head bolts prior to startup. Recheck torque on all non-metallic head bolts after pump has been operating for one week. Torque the head assembly screws in a crosswise pattern as follows:

- a. Liquid End Size D2 and D4 to 45 inch pounds.
- b. Liquid End Size D7 and D8 to 90 inch pounds.

Once all the checks and procedures described above have been carried out, start the pump.

Conduct a visual and audio check of the pump (in particular, listen for the presence of any "suspicious" noises).

Make sure that the stroke adjustment knob is unlocked.

Gradually increase the capacity until liquid can be seen flowing from the priming valve. If no priming valve is in place, when the liquid end is primed, the discharge check valves can be heard to be operating (should hear a clicking noise caused by movement of check valve balls). When liquid end is primed, stop the pump and close the priming valve.

Adjust the pump to the desired capacity. Lock the stroke adjustment knob (Item 8 in *Figure 1*).

3.4 CAPACITY CALIBRATION

After the first 12 hours of operation, the pump may be tested and calibrated to find the exact pump capacity under specific operating conditions. Usually, calibrating the pump at only 100, 50 and 10 percent capacity settings is enough to indicate pump performance throughout the adjustment range.

The pump can be calibrated by measuring the decrease in liquid level pumped from a calibrated vessel. This method is recommended for hazardous liquids because it eliminates operator contact with the liquid. Calibration columns are available for convenient and accurate calibration of the pump. Contact your local Milton Roy representative for more information.

⚠ WARNING FOR SAFETY REASONS, A CHECK VALVE IS RECOMMENDED FOR USE IN THE DISCHARGE LINE NEAR THE POINT WHERE THE LINE ENTERS A HIGH-PRESSURE PROCESS VESSEL.

SECTION 4 - MAINTENANCE

4.1 PREVENTATIVE MAINTENANCE

Drive

Initially, change the oil in the pump drive assembly after the first 1000 hours of operation. Thereafter, change drive oil on an annual basis or after every 5000 hours of operation.

The drive should be refilled with 1 quart of Mobil SHC 629:

Viscosity @ 100° F	= 726 SSU
Viscosity Index	= 149
ISO Grade	= 150

Diaphragm Assembly

The MacRoy® D diaphragm should be replaced annually or every 5000 hours of operation to avoid the possibility of failure. Refer to the instructions in Section 4.6 Diaphragm and Oil Seal Bellows Replacement.

Oil Seal Bellows

The MacRoy® D oil seal bellows should only be replaced if failure of the bellows has occurred. Oil seal bellows replacement requires the removal of the diaphragm assembly, so it is recommended that the oil seal and diaphragm assembly be replaced at the same time. Refer to the instructions in Section 4.6 Diaphragm and Oil Seal Bellows Replacement.

Check Valves

As in the case of the diaphragm, Milton Roy recommends that check valve balls, seats, gaskets and O-rings be replaced on an annual basis or every 5000 hours of operation. If highly corrosive material (acids and slurries etc.) is being pumped, more frequent replacement may be required. Complete instructions for replacement of worn check valves are given in Section 4.5 Corrective Maintenance.

4.2 RETURNING PUMPS TO THE FACTORY FOR REPAIR

Pumps can not be accepted for repair without a Return Material Authorization. Pumps should be clearly labeled to indicate the liquid being pumped. Process liquid should be flushed from the pump liquid end and oil should be drained from the pump housing before the pump is shipped.

NOTE:

United States of America Federal law prohibits handling of equipment that is not accompanied by an OSHA Safety Data Sheet (SDS). A completed SDS must be packed in the shipping crate with any pump shipped for repair. These safety precautions will aid the troubleshooting and repair procedure and preclude serious injury to repair personnel from hazardous residue in pump liquid end. A Safety Data Sheet must accompany all returns.

All inquiries or parts orders should be addressed to your local Milton Roy representative or distributor. Representatives can be found on our website www.miltonroy.com

4.3 ROUTINE MAINTENANCE

Milton Roy MacRoy® D pumps are carefully designed, manufactured and assembled to give reliable service with minimal maintenance. However, a weekly maintenance check is recommended to confirm proper operation of the pump.

Visual Check of Seal Integrity of Mechanical Assembly, Figure 6.

Check for leaks in the following components. If leaks exist, contact Milton Roy for assistance.

1. Motor flange: If leaking, replace motor flange sealing gasket (Item 11 in Figure 6).
2. Stroke adjustment knob: If leaking, replace stroke adjustment seal (Item 160 in Figure 6).

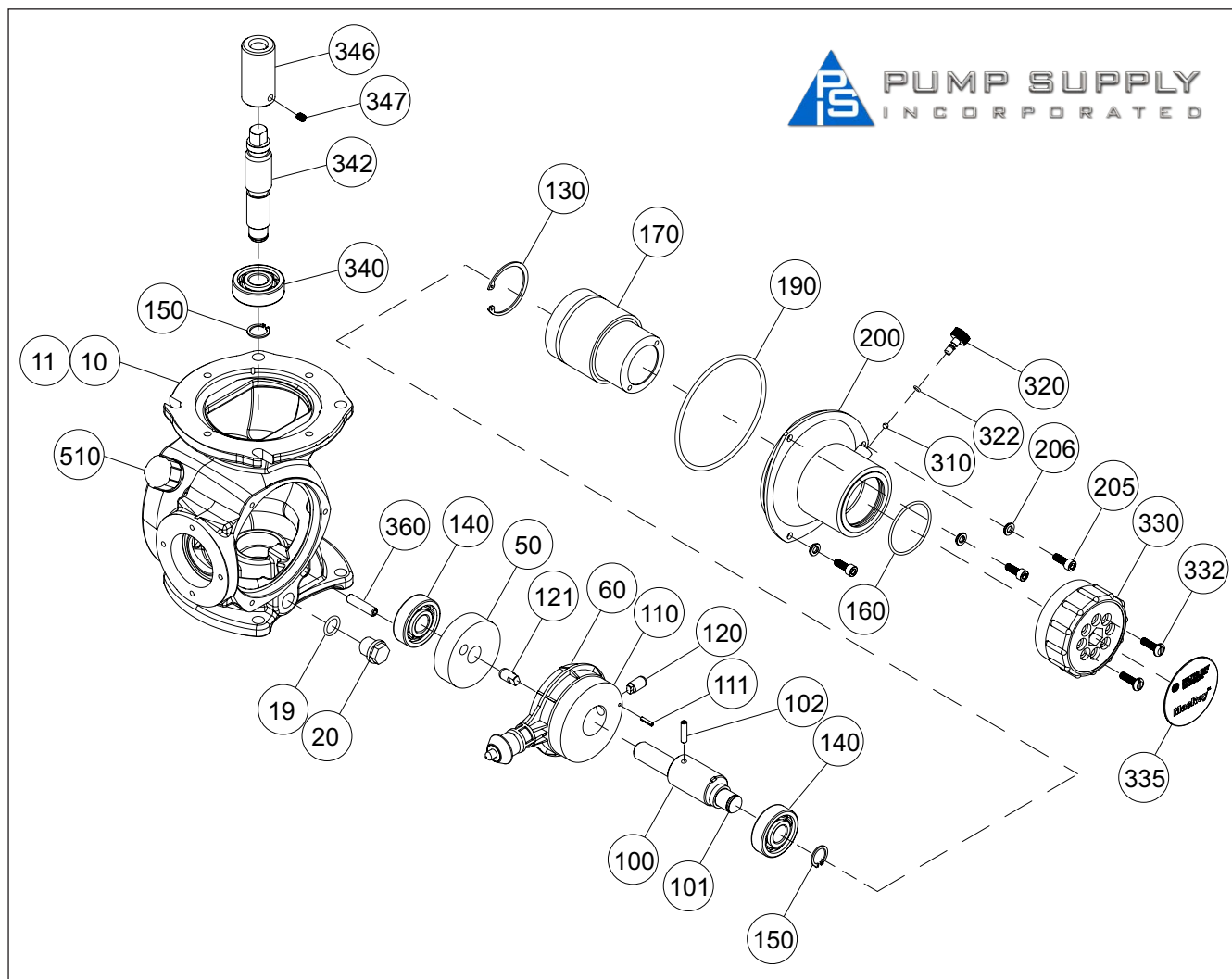

Figure 6. Drive Assembly (10227280007)

ITEM NO.	NOMENCLATURE	ITEM NO.	NOMENCLATURE	ITEM NO.	NOMENCLATURE
10	Housing	121	Gear Key	322	O-ring
11	Gasket	130	Retaining Ring	330	Stroke Adj. Knob
19	O-ring	140	Bearing	332	Screw
20	Oil Drain Plug	150	Retaining Ring	335	Sticker
50	Gear	160	Seal	340	Bearing
60	Connecting Rod	170	Stroke Adj. Screw	342	Worm
100	Male Eccentric	190	O-ring	346	Motor Coupling
101	Drive Shaft	200	Side Cover	347	Screw
102	Spring Pin	205	Screw	360	Set Screw
110	Female Eccentric	206	Washer	510	Breather Plug
111	Spring Pin	310	Stroke Lock		
120	Stroke Adjust Key	320	Stroke Lock		

SECTION 4 - MAINTENANCE

Checking the Pump Capacity

Assuming the pump has been calibrated as described in Section 3, the capacity can be checked by shutting the valve from the supply vessel and opening the valve from the calibration column to the suction side of the liquid end. Measure the volume of pumped liquid for a given period of time at the various settings.

If a calibration column is not installed in the suction piping, place the foot valve (or suction line) in a calibrating chamber (graduated reservoir). Measure the volume of pumped liquid for a given period of time at the various settings.

Occurrence of Leak From Detection Ports

Determine whether the product collected at the detection port in the liquid end mounting assembly is lubricating oil or the pumped fluid.

If the product is pumped fluid, the diaphragm has failed. If the product is lubricating oil, the oil seal bellows has failed. Proceed with its replacement (see Section 4.6 Diaphragm and Oil Seal Bellows Replacement).

4.4 SPARE PARTS

The following spare parts should be stocked for each pump to prevent serious delays in repairs. (Refer to Figures 7 thru 15).

Parts orders must include the following:

1. Quantity required.
2. Part number.
3. Part description.
4. Pump serial number (found on nameplate).
5. Pump product code (found on nameplate).

NOTE:

Always include the serial number and product code in all correspondence regarding the unit.

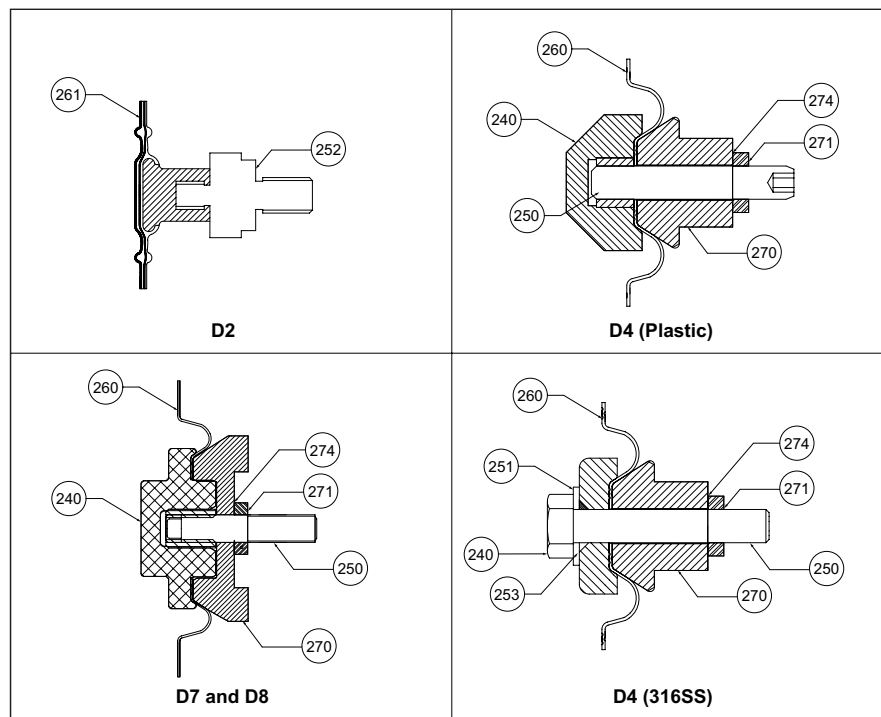

Figure 7. Diaphragm Assemblies By Liquid End Size and Material

SECTION 4 - MAINTENANCE

4.4.1 Size D2 Liquid Ends - PVC, PVDF, Polypropylene, Polymer and H₂SO₄.

Liquid End Kit for D2 PVC/PVDF/Polypropylene RPM 099, Includes:

- 1 each, Diaphragm: Item 260 in *Figure 9*.
- 1 each, Oil Seal Bellows: Item 70 in *Figure 9*.
- 2 each, O-Ring: Item 419, Seat: Item 420, Ball: Item 422, Cartridge: Item 426 and Washer: Item 427 in *Figure 9*.

Liquid End Kit for D2 Polymer RPM 196, Includes:

- 1 each, Diaphragm: Item 260 in *Figure 9*.
- 1 each, Oil Seal Bellows: Item 70 in *Figure 9*.
- 2 each, O-Ring: Item 419, Seat: Item 420, Ball: Item 422, Cartridge: Item 426, Washer: Item 427 and Spring: Item 428 (Discharge Only) in *Figure 9*.

Liquid End Kit for D2 H₂SO₄ Includes:

- 1 each, Diaphragm: Item 260 in *Figure 9*.
- 1 each, Oil Seal Bellows: Item 70 in *Figure 9*.
- 2 each, O-Ring: Item 419, Seat: Item 420, Ball: Item 422, Cartridge: Item 426 and Washer: Item 427 *Figure 9*.

Liquid End Kit for D2 PVC / PVDF Double Diaphragm RPM 161, Includes:

- 1 each, Diaphragm: Item 260 in *Figure 9*.
- 1 each, Oil Seal Bellows: Item 70 in *Figure 9*.
- 1 each, Diaphragm: Item 264 in *Figure 15*.
- 2 each, O-Ring: Item 419, Seat: Item 420, Ball: Item 422, Cartridge: Item 426 and Washer: Item 427 in *Figure 9*.



4.4.2 Size D4 Liquid Ends - PVC, PVDF, Polypropylene, Polymer, H₂SO₄ and Slurry.

Liquid End Kit for D4 PVC/PVDF/Polypropylene RPM 102, Includes:

- 1 each, Diaphragm: Item 260 in *Figure 12*.
- 1 each, Oil Seal Bellows: Item 70 in *Figure 12*.
- 1 each, PTFE Washer: Item 274 in *Figure 12*.
- 2 each, Cartridge Assembly: (P/N 36306) Included in Kit.

Liquid End Kit for D4 Polymer RPM 196, Includes:

- 1 each, Diaphragm: Item 260 in *Figure 12*.
- 1 each, Oil Seal Bellows: Item 70 in *Figure 12*.
- 1 each, PTFE Washer: Item 274 in *Figure 12*.
- 2 each, O-Ring: Item 419, Seat: Item 420, Ball: Item 422, Fitting: Item 424, Cartridge: Item 426, Washer: Item 427 and Spring: Item 428 in *Figure 12*.

Liquid End Kit for D4 H₂SO₄ NPT RPM 173, Includes:

- 1 each, Diaphragm: Item 260 in *Figure 12*.
- 1 each, Oil Seal Bellows: Item 70 in *Figure 12*.
- 1 each, PTFE Washer: Item 274 in *Figure 12*.
- 2 each, Cartridge Assembly: (P/N 39461) Included in Kit.

Liquid End Kit for D4 H₂SO₄ Tubing RPM 174, Includes:

- 1 each, Diaphragm: Item 260 in *Figure 12*.
- 1 each, Oil Seal Bellows: Item 70 in *Figure 12*.
- 1 each, PTFE Washer: Item 274 in *Figure 12*.
- 2 each, Cartridge Assembly: (P/N 39461) Included in Kit and Coupling Nut: Item 428 in *Figure 12*.

Liquid End Kit for D4 Slurry RPM 212, Includes:

- 1 each, Diaphragm: Item 260 in *Figure 12*.
- 1 each, Oil Seal Bellows: Item 70 in *Figure 12*.
- 2 each, Check Valve Assembly: Item 425 in *Figure 12*.

SECTION 4 - MAINTENANCE

Liquid End Kit for D4 PVC / PVDF Double Diaphragm RPM 163, Includes:

- 1 each, Diaphragm: Item 260 in *Figure 12*.
- 1 each, Oil Seal Bellows: Item 70 in *Figure 12*.
- 1 each, Diaphragm: Item 264 in *Figure 15*.
- 1 each, PTFE Washer: Item 274 in *Figure 12*.
- 2 each, Cartridge Assembly.: (P/N 36306) Included in Kit.

NOTE:

Liquid end sizes D2 and D4 metallic check valves (except Slurry) are precision assembled at the factory. Do not attempt to disassemble these cartridges.

4.4.3 Size D2 and D4 Liquid Ends - Stainless steel

Liquid End Kit for D2/D4 316SS RPM 101/ RPM 104, Includes:

- 1 each, Diaphragm: Item 260 in *Figure 10/11*.
- 1 each, O-ring: Item 253 in *Figure 11* (D4 only).
- 1 each, PTFE Washer: Item 274 in *Figure 11* (D4 only).
- 1 each, Oil Seal Bellows: Item 70 in *Figure 10/11*.
- 2 each, Check Valve Assembly: Item 425 in *Figures 10 and 11*.

Liquid End Kit for D2/D4 316SS Double Diaphragm RPM 162/164, Includes:

- 2 each(D4) 1 each (D2), Diaphragm: Item 260 in *Figure 10/11*.
- 1 each, Oil Seal Bellows: Item 70 in *Figure 10/11*.
- 1 each, Diaphragm: Item 264 in *Figure 15* (D2 only).
- 1 each, O-ring: Item 253 in *Figure 11* (D4 only)
- 1 each, PTFE Washer: Item 274 in *Figure 11* (D4 only).
- 2 each, Check Valve Assembly: Item 425 in *Figures 10 and 11*.

NOTE:

The check valves for the size D7 and D8-PVC, PVDF and Polypropylene liquid ends contain a removable seat, which permits the replacement of the seat, O-ring and ball into a reusable valve body. The liquid end size D7 and D8-Stainless Steel check valve has an integral ball seat, which necessitates replacement of the entire check valve assembly.

4.4.4 Size D7 and D8 - PVC, PVDF, Polypropylene, H₂SO₄, Polymer and Slurry Liquid Ends

Liquid End Kit for D7/D8 PVC / PVDF / H₂SO₄ RPM 135/105(PVC & Black PP) RPM 136/106(PVDF) RPM 175/183(H₂SO₄), Includes:

- 1 each, Diaphragm: Item 260 in *Figure 13*.
- 1 each, Oil Seal Bellows: Item 70 in *Figure 13*.
- 1 each, PTFE Seal Ring: Item 210 in *Figure 13*.
- 2 each, Seat: Item 420, Ball: Item 422 in *Figure 13*.
- 4 each, O-ring: Item 419 in *Figure 13*.

Liquid End Kit for D7/D8 Polymer RPM 211/210, Includes:

- 1 each, Diaphragm: Item 260 in *Figure 13*.
- 1 each, Oil Seal Bellows: Item 70 in *Figure 13*.
- 1 each, PTFE Seal Ring: Item 210 in *Figure 13*.
- 1 each, Spring: Item 422A in *Figure 13*.
- 1 each, Poppet: Item 426A in *Figure 13*.
- 2 each, Seat: Item 420, Ball: Item 422 in *Figure 13*.
- 4 each, O-ring: Item 419 in *Figure 13*.

NOTE:

Figure 13, Item 423 (Kit) contains the following:

- 1 each, Ball: Item 422.
- 1 each, Seat: Item 420.
- 2 each, O-rings: Item 419.

SECTION 4 - MAINTENANCE

Liquid End Kit for D7/D8 Slurry RPM 215, Includes:

- 1 each, Diaphragm: Item 260 in *Figure 13*.
- 1 each, Oil Seal Bellows: Item 70 in *Figure 13*.
- 1 each, PTFE Seal Ring: Item 210 in *Figure 13*.
- 4 each, O-ring: Item 419 in *Figure 13*.
- 2 each, Check Valve Assembly: (P/N 60827) Item 425 in *Figure 13*.

4.4.5 Size D7 and D8 - Stainless Steel Liquid Ends

Liquid End Kit for D7/D8 RPM 137/107, Includes:

- 1 each, Diaphragm: Item 260 in *Figure 14*.
- 1 each, Oil Seal Bellows: Item 70 in *Figure 14*.
- 2 each, Check Valve Assembly: Item 425 in *Figure 14*.

4.5 CORRECTIVE MAINTENANCE

⚠ WARNING BEFORE CARRYING OUT ANY SERVICING OPERATION ON THE PUMP OR PIPING, DISCONNECT ELECTRICAL POWER FROM THE PUMP AND TAKE THE NECESSARY STEPS TO ENSURE THAT ANY HARMFUL LIQUID CANNOT COME INTO CONTACT WITH PERSONNEL. SUITABLE PROTECTIVE EQUIPMENT MUST BE PROVIDED. BE SURE THAT THERE IS NO FLUID PRESSURE IN THE PUMP LIQUID END AND PIPING.

Cleaning Fouled Check Valves:

Check valve assemblies are designed to be self-cleaning and should seldom need servicing. Fouled check valves can usually be cleaned by pumping a solution of mild detergent and warm water (if compatible with liquid being pumped) for 15 minutes, followed by flushing with water.

Check Valve Replacement:

General

Before beginning work on the valve assemblies, make sure the suction and discharge shut-off valves are closed and that pressure has been bled from the pump liquid end. When replacing the valves, be sure to replace the valve O-rings. Pay close attention to the proper assembly and orientation of the check valves as shown in each Liquid End figure. In the case of plastic check valves for liquid end size D7 and D8, be certain that the ball is placed on the sharp edge of the valve seat.

⚠ WARNING BE SURE TO FOLLOW INSTRUCTIONS CAREFULLY AND REFER TO THE APPROPRIATE FIGURE WHEN REASSEMBLING CHECK VALVES. IF CHECK VALVE CARTRIDGES ARE INSTALLED INCORRECTLY, ONE OF THE FOLLOWING WILL OCCUR:

- A. IMMEDIATE AND SEVERE DAMAGE TO PUMP MECHANISM.
- B. NO PUMPING OF FLUIDS.
- C. REVERSE PUMPING ACTION (FROM DISCHARGE LINE INTO SUCTION LINE).

Preliminary Operations

1. Set the pump capacity knob to 0%. If stroke locking screw was previously tightened, slightly loosen the locking screw.
2. Disconnect power to pump motor. Check that the equipment cannot be accidentally started. Place a notice at the location of the power switch indicating that the pump is being serviced.
3. Disconnect the pump hydraulically by removing pipe or tubing connections to suction and discharge check valves.



SECTION 4 - MAINTENANCE

4.5.1 Check Valve Replacement: Liquid Ends D2 and D4 - PVC, PVDF, H2SO4 and Polypropylene (See Figure 9 or 12)

CAUTION NOTE THAT THE SEAT ORIENTATION IS DIFFERENT INSIDE THE SUCTION AND DISCHARGE CHECK VALVES, BUT THE SEAT MUST ALWAYS BE BELOW THE BALL WHEN INSTALLED.

CAUTION DO NOT APPLY PTFE TAPE TO THE THREADS OF CHECK VALVE BODY THAT SCREWS INTO THE HEAD (280), AS THIS MAY PREVENT ADEQUATE SQUEEZE FROM BEING APPLIED TO THE VALVE O-RING WHICH COULD RESULT IN LEAKAGE.

1. Unscrew the valve body (424) from the pump head (280).
2. Remove the cartridge valve assembly: cartridge includes ball (422), seat (420), ball guide (426), O-ring (419 and 421(D4 PVC / PVDF / POLY only)) and washer (427).
3. Clean the valve body (424) and threaded port in the head (280).
4. Place a new washer (427) into valve body (424).
5. Install new check valve assembly in orientation shown.

On discharge side, drop cartridge assembly into threaded port in head. The O-ring should be stretched around outside of cartridge on same end as ball seat. Screw valve body into discharge side of diaphragm head until valve is hand tight.

Do not overtighten.

On suction side, drop the cartridge assembly into check valve body. The O-ring should be stretched around outside of cartridge on opposite end of ball seat. Screw the suction valve body with cartridge valve into suction side of head hand tight. **Do not overtighten.**



4.5.2 Check Valve Replacement: Liquid Ends D2 and D4 - Polymer (See Figure 9 or 12)

CAUTION NOTE THAT THE SEAT ORIENTATION IS DIFFERENT INSIDE THE SUCTION AND DISCHARGE CHECK VALVES, BUT THE SEAT MUST ALWAYS BE BELOW THE BALL WHEN INSTALLED.

CAUTION DO NOT APPLY PTFE TAPE TO THE THREADS OF CHECK VALVE BODY THAT SCREWS INTO THE HEAD (280), AS THIS MAY PREVENT ADEQUATE SQUEEZE FROM BEING APPLIED TO THE VALVE O-RING WHICH COULD RESULT IN LEAKAGE.

Suction

1. Unscrew the valve body (424) from the pump head (280).
2. Remove the valve assembly: assembly includes ball (422), seat (420), Cartridge (426), O-ring (419) and washer (427).
3. Clean the valve body (424) and threaded port in the head (280).
4. Place a new washer (427) into valve body (424). Place new seat (420) and new ball (422) inside new cartridge (426) and place into valve body.
5. Add O-ring (419) and install new check valve assembly in orientation shown.

On suction side, drop the cartridge assembly into check valve body. The O-ring should be stretched around outside of cartridge on opposite end of ball seat. Screw the suction valve body with cartridge valve into suction side of head hand tight. **Do not overtighten.**

Discharge

1. Unscrew the valve body (424) from the pump head (280).
2. Remove the valve assembly: assembly includes O-ring (419), seat (420), ball (422), spring (428), cartridge (426) and washer (427).
3. Clean the valve body (424) and threaded port in the head (280).

SECTION 4 - MAINTENANCE

4. Place a new washer (427) into valve body (424). Place new spring (428), new ball (422) and new seat (420) inside new cartridge (426) and place into valve body.
5. Add O-ring (419) and install new check valve assembly in orientation shown.

On discharge side, drop cartridge assembly into threaded port in head. The O-ring should be stretched around outside of cartridge on same end as ball seat. Screw valve body into discharge side of diaphragm head until valve is hand tight.

Do not overtighten.

4.5.3 Check Valve Replacement: Liquid End Sizes D2 and D4 - Metallic (See Fig. 10 or 11)

The metallic check valves used on liquid end sizes D2 and D4 (except slurry) are precision assembled at the factory. Do not attempt to disassemble these cartridges. If they become inoperative, flush them with solvent, wash them with warm detergent and blow them out with compressed air to remove any foreign matter. If this treatment does not eliminate the trouble, the cartridge assembly should be replaced.

Disassembly

Remove the check valves by unscrewing them from the pump head.

Reassembly

Apply a small amount of thread sealing compound and PTFE pipe tape to check valve threads and install check valves by screwing them into the pump head with the flow arrows pointing up.

Do not overtighten check valves.



4.5.4 Check Valve Replacement: Liquid End Size D4 - Slurry (See Figure 11)

1. Unscrew the valve body (424) from the pump head (280).
2. Remove the valve assembly: assembly includes ball (422), check valve body (424) and retainer sleeve (428).
3. Clean the valve body (424) and threaded port in the head (280).
5. Install new check valve assembly in orientation shown.

On discharge side, drop cartridge assembly into threaded port in head. Screw valve body into discharge side of diaphragm head until valve is hand tight. **Do not overtighten.**

On suction side, drop the cartridge assembly into check valve body. Screw the suction valve body with cartridge valve into suction side of head hand tight. **Do not overtighten.**

CAUTION

THE CHECK VALVES WILL NOT OPERATE IF THEY ARE INSTALLED UPSIDE DOWN. INSTALL CHECK VALVES WITH THE FLOW ARROW POINTING IN THE DIRECTION OF PROCESS FLOW (UP). TURN CHECK VALVE ASSEMBLIES INTO LIQUID END BY HAND AND TIGHTEN. DO NOT OVERTIGHTEN, DAMAGE TO THE CHECK VALVES MAY OCCUR.

4.5.5 Replacement of Ball, Seat, & Seal: Liquid End D7 and D8 - PVC, PVDF, H₂SO₄ and Polypropylene (See Figure 13)

Disassembly

1. Unscrew the union nut (435). The union end (445) is held in place by the union nut and will separate easily from the other liquid end parts.
2. Unscrew the valve body (424) from the pump head (280).
3. Screw the union nut part way (one or two turns) onto the end of the ball guide that has the seat in it. Be sure the union nut is on loosely. This will allow a gap for the seat (420) to fall into as it is removed from the ball guide.

SECTION 4 - MAINTENANCE

4. Set the ball guide / union nut on a flat surface with the union nut down. Looking into the top of the ball guide, you will see four large holes surrounding one small hole. Insert a thin, blunt instrument such as a hex head screwdriver into the small center hole until it rests on the top of the ball (422).
5. Tap screwdriver gently with a hammer until the ball and seat are released from the ball guide.

CAUTION IF THE UNIT IS DISASSEMBLED FOR INSPECTION ONLY, BE SURE TO USE A BLUNT INSTRUMENT AND TAP GENTLY TO AVOID DAMAGING THE BALL. IF THE BALL AND / OR SEAT ARE DAMAGED DURING DISASSEMBLY, THEY WILL HAVE TO BE REPLACED. IF AVAILABLE, TO AVOID DAMAGE, IT IS ADVISABLE TO USE GENTLE AIR PRESSURE (APPLIED AT END OPPOSITE THE SEAT (420) FOR BALL AND SEAT REMOVAL)

6. Carefully remove the two O-rings (419) from the ball guide and seat.
7. Carefully clean any parts to be reused. If any chemicals are used in the cleaning process, ensure that they are compatible with the process liquid.

Reassembly

CAUTION THE ORDER OF ASSEMBLY AND ORIENTATION OF THE SUCTION AND DISCHARGE CHECK VALVES IS DIFFERENT. REFER TO *FIGURE 13* FOR PROPER ASSEMBLY ORDER AND ORIENTATION. IF CHECK VALVE CARTRIDGES ARE INSTALLED INCORRECTLY, ONE OF THE FOLLOWING WILL OCCUR:

- (A) IMMEDIATE SEVERE DAMAGE TO PUMP MECHANISM.
- (B) NO PUMPING.
- (C) REVERSE PUMPING ACTION (FROM DISCHARGE LINE INTO SUCTION LINE).

1. Drop the ball (422) into the curved inner chamber end of the body (424).

2. Set the body on a flat surface so that the end with the ball faces upward. Position seat (420) on the body, with the beveled edge of the seat facing outward. When the seat is pressed into the body, the ball should be sitting on the side with sharp corners as shown in *Figure 13*. The bevel should not face the inside of the check valve. Use a flat surface such as a board to press the seat into the body with firm, even pressure. If the seat is improperly positioned, the ball will not create a tight seal and poor pumping performance will result.
3. Fit new O-rings (419) into position on the body (424) and seat (420).

CAUTION DO NOT APPLY PTFE TAPE TO THREADS OF CHECK VALVE BODY (424) AS THIS MAY PREVENT ADEQUATE SQUEEZE FROM BEING APPLIED TO THE VALVE O-RING WHICH WOULD RESULT IN LEAKAGE.

NOTE:

To assure a tight, leak free seal, new O-rings should be used each time the check valves are disassembled.

4. Position the union end (445) onto the correct end of the body. Refer to *Figure 13*, as the correct end is determined by whether the valve is intended for the suction or discharge port of the liquid end. Slip the union nut (435) over the union end and screw tightly (hand tight only) onto the body.
5. Screw the valve assembly into the pump head (hand tight only). **Do not overtighten.**



SECTION 4 - MAINTENANCE

4.5.6 Check Valve Replacement: Liquid End Sizes D7 and D8 - Polymer (See Figure 13)

Suction

Follow the instruction for replacement of ball, seat and seal: liquid end D7 and D8 - PVC, PVDF, H₂SO₄ and polypropylene paragraph 4.5.5.

The procedures are the same.

Discharge

1. Unscrew the valve body (424) from the pump head (280).
2. Remove the valve assembly: assembly includes two O-rings (419), seat (420), ball (422), poppet (426), spring (423) and check valve body (424).
3. Replace O-rings (419), seat (420), ball (422), poppet (426) and spring (423).
4. Clean the valve body (424) and threaded port in the head (280).
5. Install new check valve assembly in orientation shown.

On discharge side, drop cartridge assembly into threaded port in head. Screw valve body into discharge side of diaphragm head until valve is hand tight. **Do not overtighten.**

4.5.7 Check Valve Replacement: Liquid End Sizes D7 and D8 - Slurry (See Figure 13)

1. Unscrew the valve body (424) from the pump head (280).
2. Remove the valve assembly: assembly includes two O-rings (419), slurry seal ring (420), ball (422), check valve body (424) and dowel pin.
3. Clean the valve body (424) and threaded port in the head (280).
4. Install new check valve assembly in orientation shown.

On discharge side, drop cartridge assembly into threaded port in head. Screw valve body into discharge side of diaphragm head until valve is hand tight. **Do not overtighten.**

On suction side, drop the cartridge assembly into check valve body. Screw the suction valve body with cartridge valve into suction side of head hand tight. **Do not overtighten.**

4.5.8 Check Valve Replacement: liquid End Sizes D7 and D8 - Stainless Steel (See Figure 14)

Disassembly

Stainless steel check valves differ from the plastic versions in that the ball seat is integral to the ball guide. The seats cannot easily be inspected for damage or wear. If you suspect that the check valve may be damaged or worn, replace the entire check valve assembly as per the instructions below.

1. Unscrew the coupling (445).
2. Unscrew the check valve assembly (425) from the liquid end.



SECTION 4 - MAINTENANCE

Reassembly

▲ CAUTION THE ORDER OF ASSEMBLY AND ORIENTATION OF THE SUCTION AND DISCHARGE CHECK VALVES IS DIFFERENT. REFER TO *FIGURE 14* FOR PROPER ASSEMBLY ORDER AND ORIENTATION. IF CHECK VALVE CARTRIDGES ARE INSTALLED INCORRECTLY, ONE OF THE FOLLOWING WILL OCCUR:

- (A) IMMEDIATE SEVERE DAMAGE TO PUMP MECHANISM.
- (B) NO PUMPING.
- (C) REVERSE PUMPING ACTION (FROM DISCHARGE LINE INTO SUCTION LINE).

1. Screw the correct end of the check valve assembly into the pump head, trapping a new O-ring between the pump head and the check valve assembly.

▲ CAUTION DO NOT APPLY PTFE TAPE TO THREADS OF CHECK VALVE BODY AS THIS MAY PREVENT ADEQUATE SQUEEZE FROM BEING APPLIED TO THE VALVE O-RING WHICH WOULD RESULT IN LEAKAGE.

NOTE:

To assure a tight, leak free seal, new O-rings should be used each time the check valves are disassembled.

2. Screw the coupling (445) onto the check valve assembly, trapping a new O-ring (419) between the coupling and the check valve assembly.



4.6 DIAPHRAGM AND OIL SEAL BELLOWS REPLACEMENT

▲ CAUTION BEFORE BEGINNING DIAPHRAGM REPLACEMENT, MAKE SURE THAT ALL SHUTOFF VALVES ARE CLOSED AND ALL PRESSURE IS BLED FROM THE LIQUID END.

If failure of the oil seal bellows has occurred, it is recommended that the diaphragm assembly and oil seal bellows be replaced at the same time.

4.6.1 Diaphragm Replacement: Liquid End Size D2 (See Figures 7, 9 and 10)

1. Loosen the head screws (290) and remove the diaphragm head (280). Mark the suction and discharge ports on the diaphragm head prior to removal.
2. Remove the motor fan cover and turn the motor by hand while adjusting the capacity control knob to 100%. With the capacity set at 100%, turn the motor fan until the diaphragm (260) is in the full forward position (top dead center).
3. Hold the outer edge of the diaphragm and turn it counterclockwise to unscrew it from the pump drive.
4. Discard and replace with new diaphragm. Make sure that adaptor (252) is screwed in tightly to connecting rod (Item 60 in *Figure 6*). Make sure that seat ring (Item 230 in *Figures 9 and 10*) is in place. Apply a thin layer of silicone grease to back (rubber side) of diaphragm before installation. Holding the edges of the diaphragm, screw the diaphragm assembly onto the male thread of the adaptor piece (252) until it reaches its mechanical stop.
5. With the capacity still set at 100% turn the motor fan until the new diaphragm is in the farthest rearward position (bottom dead center).
6. Reattach the diaphragm head with the suction and discharge ports in the correct positions. Tighten the screws in a crosswise pattern to a torque of 45 in-lb.

SECTION 4 - MAINTENANCE

7. While turning the motor fan, set the stroke adjustment knob to the 0% position.
8. Reinstall motor fan cover.

4.6.2 Diaphragm Replacement: Liquid End Sizes D4, D7 and D8 (See Figures 7, 11-14)

1. Mark the suction and discharge ports on the diaphragm head prior to removal. Loosen the head screws (290) and remove the diaphragm head (280).
2. Remove the motor fan cover and turn the motor by hand while adjusting the capacity control knob to 100%. With the capacity set at 100%, turn the motor fan until the diaphragm cap (240) is in the full forward position (top dead center).
3. Hold the outer edge of the diaphragm (260) and turn it counterclockwise to unscrew it from the pump drive.
4. While clamping on the hex on the diaphragm cap (240), disassemble diaphragm assembly by removing the hex nut (271) on the back of the diaphragm support nut (270).
5. Make sure that stainless steel support nut (270) is clean and free of corrosion. When cleaning the support nut, take care not to scratch the smooth angled surface of the support nut. If corrosion cannot be removed without damaging the support nut, replace with a new one.
6. Install new diaphragm (260) onto diaphragm cap (240) with the convolution in correct orientation. As shown in figures, the convolution in the Teflon diaphragm should be facing down away from diaphragm cap (240) and against (or pointing towards) the stainless steel support nut (270).
7. For Size D4-stainless steel liquid ends, slide bolt (250), washer (251) and O-ring (253) through the diaphragm cap and diaphragm as shown in *Figure 7*. For all other liquid ends, install set screw (Item 250 in *Figure 6*) into diaphragm cap (240), with hex hole in screw facing outward, until it is bottomed out (hand tight only) in the diaphragm cap.
8. Slide support nut (270) onto set screw in correct orientation shown in *Figure 7*.
9. Install hex nut onto back of support nut and tighten to the following torque values dependent on liquid end size and material. Torque diaphragm assembly as follows:
 - a) Liquid End Size D7 and D8 to 20 foot pounds.
 - b) Liquid End Size D4-Plastic to 45 inch pounds.
 - c) Liquid End Size D4-Stainless Steel tighten until washer (251) is contacting diaphragm cap (240).
10. Make sure that support ring (230) is in place and then reinstall diaphragm assembly.
11. Apply thin layer of O-ring type grease to back of support nut (270) and reinstall thin PTFE washer (274) to back of support nut.
12. Make sure that oil seal clamp ring (210) is in place. Screw diaphragm assembly into connecting rod (Item 60 in *Figure 6*) until it reaches its mechanical stop.

NOTE:

Steps 11 and 12 are applicable to Liquid End Size D4.



SECTION 4 - MAINTENANCE

13. Apply a thin layer of grease to the back of hex nut (271).
14. Make sure that spring (Item 272 in *Figure 13 and 14*) is in place and connecting rod is in full-forward position (at 100% capacity setting). Screw diaphragm assembly into connecting rod cross piece (61) until it reaches its mechanical stop.

NOTE:

Steps 13 and 14 are applicable to Liquid End Size D7 and D8.

15. With the capacity still set at 100% turn the motor fan until the diaphragm is pulled back to the rearward position (bottom dead center).
16. Reattach the diaphragm head with the suction and discharge ports in the correct positions. Torque the head assembly screws in a crosswise pattern as follows:
 - a) Liquid End Size D2 and D4 to 45 inch pounds.
 - b) Liquid End Size D7 and D8 to 90 inch pounds.
17. While turning the motor fan, set the stroke adjustment knob to the 0% position.
18. Reinstall motor fan cover.

4.7 OIL SEAL BELLOWS REPLACEMENT (ITEM 70 IN FIGURES 9 THROUGH 14)

CAUTION BEFORE BEGINNING OIL SEAL REPLACEMENT, MAKE SURE ALL SHUT-OFF VALVES ARE CLOSED AND ALL PRESSURE HAS BEEN BLED FROM THE LIQUID END (PUMP HEAD). WHEN REPLACING THE OIL SEAL, THE DIAPHRAGM ASSEMBLY MUST BE REMOVED FIRST. FOR EASE OF SERVICE, IT IS RECOMMENDED THAT THE OIL SEAL BE REPLACED IN CONJUNCTION WITH THE DIAPHRAGM ASSEMBLY.

1. Disconnect connections to the pump motor terminal box. Be sure to note the wiring layout before disconnecting from box.
2. Set the stroke adjusting knob to 100%.
3. Disconnect the suction and discharge connections to the pump head check valves.
4. Mark the suction and discharge ports on the diaphragm head prior to removal. Loosen the head screws (290) and remove the diaphragm head (280).
5. Remove the motor fan cover and turn the motor by hand while adjusting the capacity control knob to 100%. With the capacity set at 100%, turn the motor fan until the diaphragm assembly is in the full forward position (top dead center).
6. Hold the outer edge of the diaphragm assembly (260) and turn it counterclockwise to unscrew it from the pump drive.
7. Remove the diaphragm support ring (230) from the spacer (225).
8. Drain the oil out of the pump drive by removing the drain plug from the pump housing.

Illinois Location:

(847) 841-7867
 860 Church Rd Elgin, IL 60

Minnesota Location:

(651) 758-7867
 330 Mill Bay South Suite 1
 Afton, MN 55001

PumpSupplyInc.com

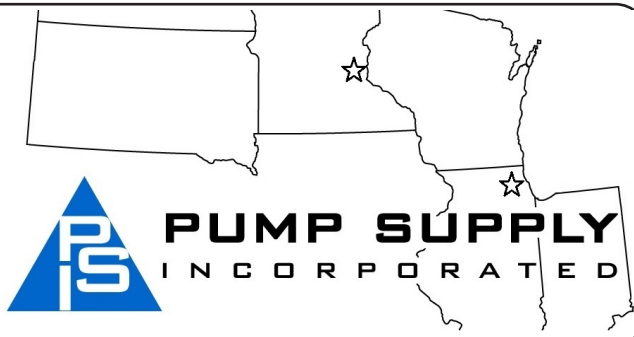

SECTION 4 - MAINTENANCE

9. Remove oil seal bellows clamping components as follows:
 - a) On Liquid End Size D2 models (*Figures 9 and 10*), remove adaptor piece (252), clamp ring (210), mounting screws (227) and spacer (225).
 - b) On Liquid End Size D4 models (*Figures 11 and 12*), remove oil seal clamp ring (210), mounting screws (227) and spacer (225).
 - c) On Liquid End Size D7 and D8 models (*Figure 13 and 14*), remove spring (272), unscrew adapter (61), seal ring (210) mounting screws (227 & 228) and spacer (225).
10. Pull the oil seal (70) off the connecting rod.
11. Install a new oil seal onto connecting rod.
12. Apply a thin layer of O-ring type grease to top of oil seal (part adjacent to connecting rod).
13. Reinstall parts removed in step 9. For Liquid ends D2, D7 and D8, install adaptor piece (252) or cross piece (61) before mounting spacer.
14. Remove the motor and refill pump drive with oil (1 quart of Mobil SHC 629).
15. Reinstall motor.
16. Reinstall liquid end components in accordance with the procedures found in the following:
 - a) For Liquid End Size D2 models, refer to paragraph 4.6.1, steps 4 thru 7.
 - b) For Liquid End Size D4, D7 and D8 models refer to paragraph 4.6.2, steps 10 thru 17.
17. Connect the motor in compliance with the directions marked during the prior disconnection (see also Section 2: ELECTRICAL CONNECTIONS).



4.8 RESTARTING THE PUMP

1. Reconnect the pump to the piping system.
2. Check that capacity is set to 0%.
3. Open system suction and discharge shut-off valves and restart pump.
4. Set the pump to 100% to obtain faster priming of liquid end.
5. After priming, set the pump to the desired capacity. Retighten locking screw (320, *Figure 6*).

Illinois Location:
 (847) 841-7867
 860 Church Rd Elgin, IL 60

Minnesota Location:
 (651) 758-7867
 330 Mill Bay South Suite 1
 Afton, MN 55001

PumpSupplyInc.com

PUMP SUPPLY
 INCORPORATED

SECTION 5 - PARTS LIST

GENERAL

1. This section gives information regarding replaceable components.

ILLUSTRATED PARTS LIST

1. Figure and Item Number Column
 - a. The item numbers shown in the detailed parts list correspond to the item numbers appearing on the exploded view illustration. To find an unknown part number, locate the part on the illustration and note the item number. Look for the item number on the detailed parts list. The part number is on the same line. A dash (-) precedes non-illustrated item numbers.
2. Description Column
 - a. The name of the item is in the description column.
3. Additional Information
 - a. When "Consists of" is indented under a part, that part consists of the corresponding parts referenced by part number.



4. Part Number Column
 - a. The supplier's part number is listed in the part number column.
5. Quantity Column
 - a. The numbers appearing in the quantity column are the total quantity of the listed part required in its immediate assembly.
6. Reference Code Column
 - a. This column is used to denote assembly and detail part variations among similar components (models) covered by this publication. When the symbol "A" and "B", etc. is entered in this column, the part is used only in the model at which the symbol appears. If the column is blank, the part is used in all models.

Refer to table numbers (5.1 to 5.8) for the above Parts List information.

Illinois Location:
 (847) 841-7867
 860 Church Rd Elgin, IL 60

Minnesota Location:
 (651) 758-7867
 330 Mill Bay South Suite 1
 Afton, MN 55001

PumpSupplyInc.com

PUMP SUPPLY
 INCORPORATED

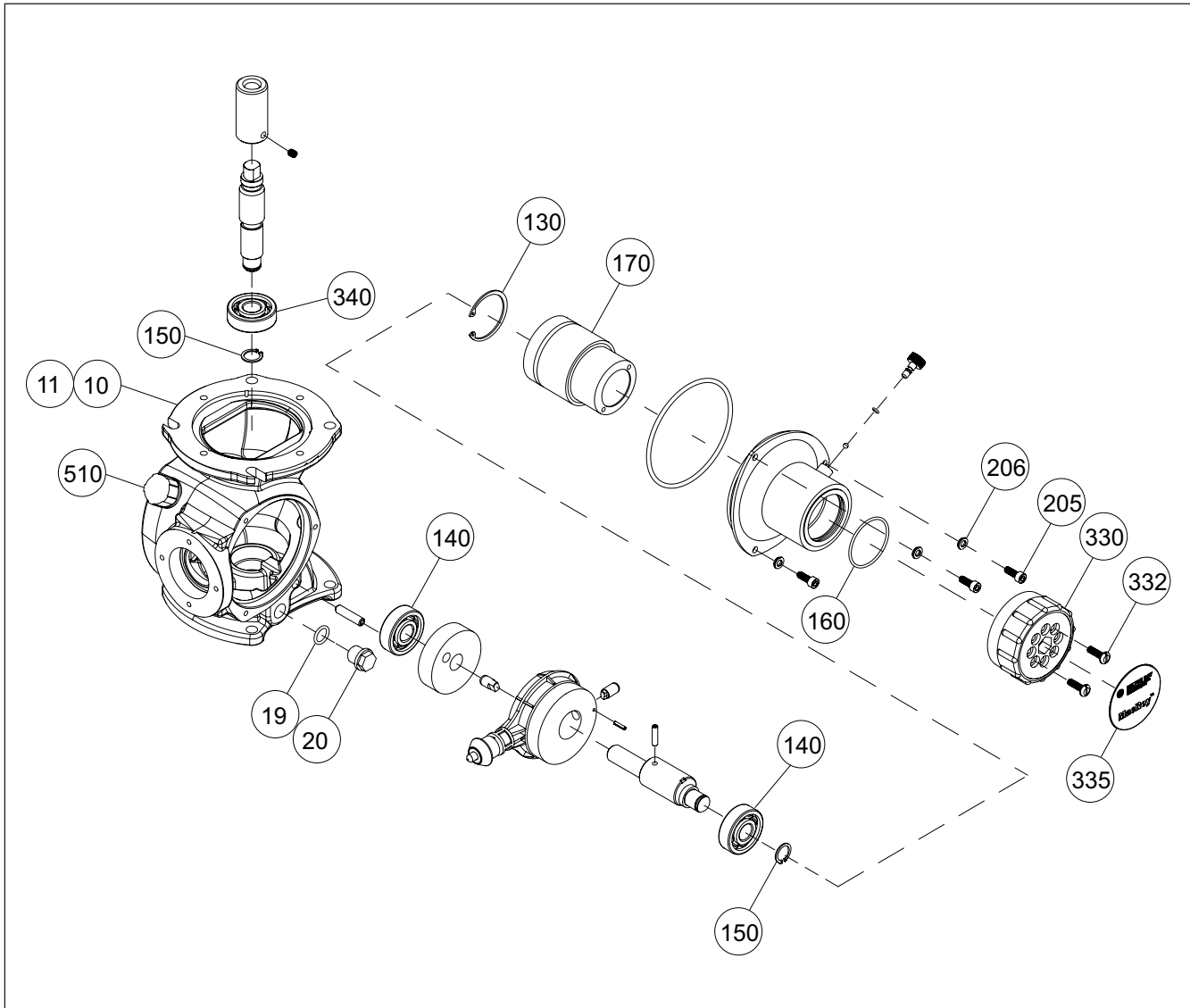



Figure 8. Drive Assembly (10227280007)

<p>Illinois Location: (847) 841-7867 860 Church Rd Elgin, IL 60</p>	
<p>Minnesota Location: (651) 758-7867 330 Mill Bay South Suite 1 Afton, MN 55001</p>	
<p>PumpSupplyInc.com</p>	



5.1 PARTS LIST FOR DRIVE

FIGURE NUMBER	ITEM NUMBER	DESCRIPTION	PART NUMBER	QUANTITY PUMP
8	10	Drive Housing Assembly, D2, 43 SPM, (NE56C)	SD-40-01-NE56C	1
		Drive Housing Assembly, D2, 43 SPM, (IEC71)	SD-40-01-IEC71	1
		Drive Housing Assembly, D2, 86 SPM, (NE56C)	SD-20-01-NE56C	1
		Drive Housing Assembly, D2, 86 SPM, (IEC71)	SD-20-01-IEC71	1
		Drive Housing Assembly, D2, 173 SPM, (NE56C)	SD-10-01-NE56C	1
		Drive Housing Assembly, D2, 173 SPM, (IEC71)	SD-10-01-IEC71	1
		Drive Housing Assembly, D2, 120 SPM, (NE56C)	SD-15-01-NE56C	1
		Drive Housing Assembly, D2, 120 SPM, (IEC71)	SD-15-01-IEC71	1
		Drive Housing Assembly, D4/7, 43 SPM, (NE56C)	SD-40-06-NE56C	1
		Drive Housing Assembly, D4/7, 43 SPM, (IEC71)	SD-40-06-IEC71	1
		Drive Housing Assembly, D4/7, 86 SPM, (NE56C)	SD-20-06-NE56C	1
		Drive Housing Assembly, D4/7, 86 SPM, (IEC71)	SD-20-06-IEC71	1
		Drive Housing Assembly, D4/7, 173 SPM, (NE56C)	SD-10-06-NE56C	1
		Drive Housing Assembly, D4/7, 173 SPM, (IEC71)	SD-10-06-IEC71	1
		Drive Housing Assembly, D4/7, 120 SPM, (NE56C)	SD-15-06-NE56C	1
		Drive Housing Assembly, D4/7, 120 SPM, (IEC71)	SD-15-06-IEC71	1
		Drive Housing Assembly, D8, 43 SPM, (NE56C)	SD-40-10-NE56C	1
		Drive Housing Assembly, D8, 43 SPM, (IEC71)	SD-40-10-IEC71	1
		Drive Housing Assembly, D8, 86 SPM, (NE56C)	SD-20-10-NE56C	1
		Drive Housing Assembly, D8, 86 SPM, (IEC71)	SD-20-10-IEC-71	1
		Drive Housing Assembly, D8, 173 SPM, (NE56C)	SD-10-10-NE56C	1
		Drive Housing Assembly, D8, 173 SPM, (IEC71)	SD-10-10-IEC71	1
	Drive Housing Assembly, D8, 120 SPM, (NE56C)	SD-15-10-NE56C	1	
	Drive Housing Assembly, D8, 120 SPM, (IEC71)	SD-15-10-IEC71	1	
	11	Gasket Motor (NEMA 56C Flanged Motor)	2250115099	1
	11	Gasket Motor (IEC71, V1 Flanged Motor)	2250121099	1
	19	O-Ring	4080068031	1
20	Oil Drain Plug	60086	1	
130	Retaining Ring	60064	1	
140	Bearing	4099994000	2	

- Items not shown.



FIGURE NUMBER	ITEM NUMBER	DESCRIPTION	PART NUMBER	QUANTITY PUMP
8	150	Retaining Ring	4040107231	2
	160	Seal (Gasket), Side Cover, Use Through 2005	2502110067N	1
	170	Seal, Oil, Use After 2005	H60766	1
	205	Stroke Adjust Screw	61331	1
	206	Socket Head Screw, M6 X 16, 304SS	4350003375N	3
	330	Washer M6 304SS	4340009065N	3
	332	Stroke Adjust Knob	70066	1
	335	Pan Head Screw, M6 X 20	70054	2
	340	Knob, Sticker MacRoy®	60996	1
	-	Bearing	61116	1
	-	Spring Pin (for IEC Motors Only)	4010003031	3
	-	Motor Mounting Bolt (IEC Motors: M8 X 25)	4350038522	4
	-	Motor Mounting Bolt (NEMA 56C Motors: 3/8-16 X 1)	4050018119	4
	-	Motor Mount Washer (IEC Motors: Spring Lockwasher 8mm)	4340009002	4
	-	Motor Mount Washer (NEMA 56C Motors: 3/8 SAE)	40476	4
	-	Base (Optional)	61266	1
	-	HEX HD, Screw, 3/8-16X1 GR5	4050018119	4
	-	Washer, 3/8	40476	4
	-	HEX Nut, 3/8-16NC Z PL	4050066016	4
	-	Gear Oil - 1 quart	4070324030	1
	510	Breather Plug / Oil Fill Cap, P/O Item 10	41065	1

- Items not shown.

Illinois Location:
 (847) 841-7867
 860 Church Rd Elgin, IL 60

Minnesota Location:
 (651) 758-7867
 330 Mill Bay South Suite 1
 Afton, MN 55001

PumpSupplyInc.com

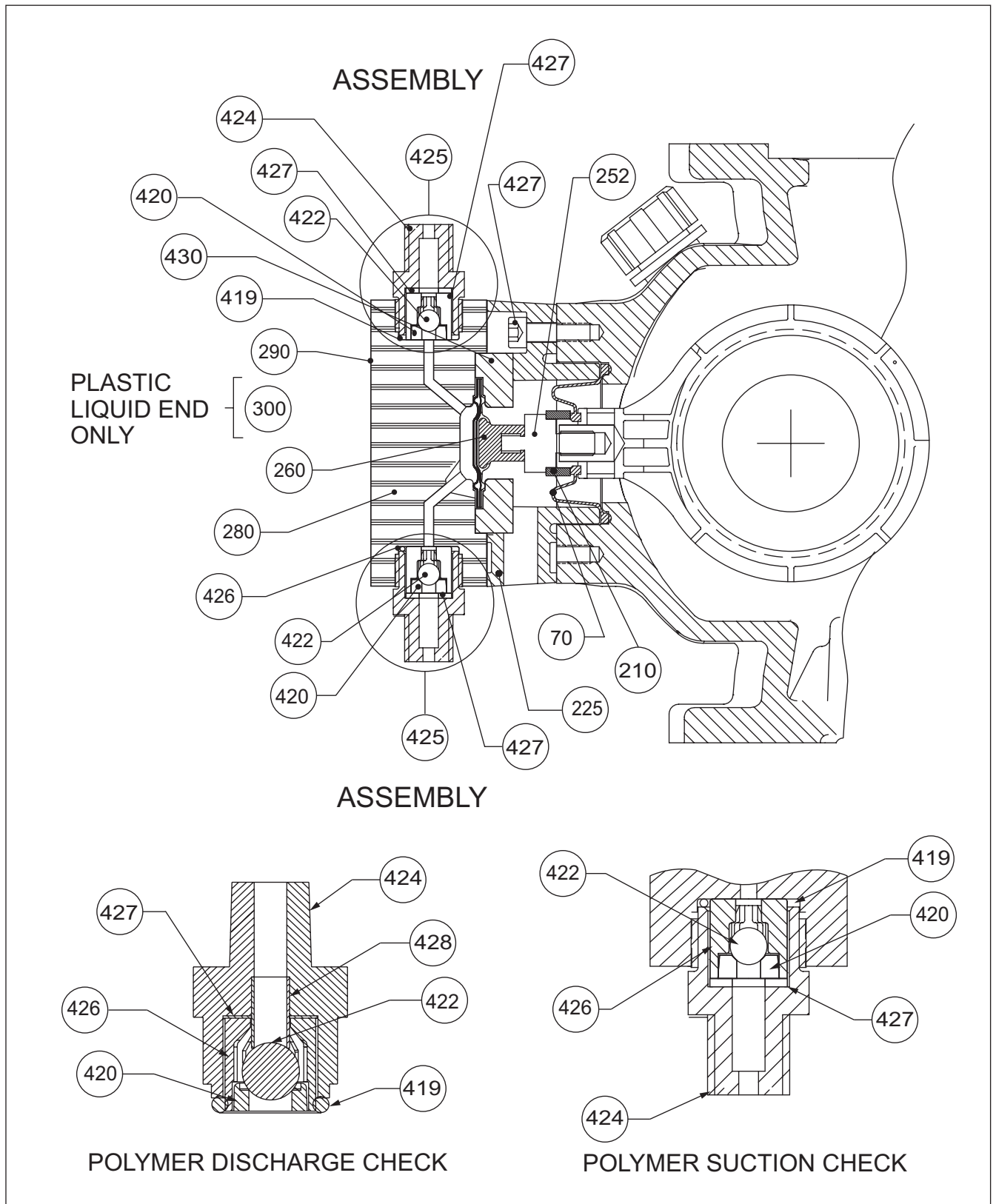

Figure 9. D2 Plastic Liquid End (10227800012)



5.2 PARTS LIST FOR D2 PLASTIC LIQUID END PVC, PVDF, BLACK POLY, H₂SO₄ AND POLYMER-NPT / PVC, PVDF AND BLACK POLY-TUBING.

Model:	Reference Code:	Model:	Reference Code:
D2__8P_____	A (PVC NPT)	D2__4P_____	E (BLACK PP NPT)
D2__8T_____	B (PVC TUBE)	D2__4T_____	F (BLACK PP TUBE)
D2__2P_____	C (PVDF NPT)	D2__NP_____	G (H2SO4 NPT)
D2__2T_____	D (PVDF TUBE)	D2__PP_____	H (POLYMER NPT)

FIGURE NUMBER	ITEM NUMBER	DESCRIPTION	PART NUMBER	QUANTITY PUMP	REFERENCE CODE
9	70	Diaphragm / Oil Seal Bellows	60048	1	
	210	Oil Seal Clamp Ring	60043	1	
	225	Spacer	61035	1	
	227	Pan Head Screw, M6 X 20	70054	4	
	230	Diaphragm Seat Ring	61088	1	
	252	Adapter	61083	1	
	260	Diaphragm, PTFE	30916	1	
	280	Diaphragm Head, PVC	61089	1	A, B, G
	280	Diaphragm Head, PVDF	61090	1	C, D
	280	Diaphragm Head, BLACK PP	61377	1	E, F
	280	Diaphragm Head, POLYMER	69001	1	H
	281	Decal	60534	1	
	290	Pan Head Screw, #10-24 X 3/4	61059	4	
	300	Flat Washer, 1/4 18.8SS	4040005012	4	A, E, G
	300	Flat Washer, #10 18.8SS	4040002053	4	B, C, D, F
	419	O-Ring, 0.549 ID X 103W(AFLAS)	36103	2	
	419	O-Ring, 2-113 Viton	40905	2	H
	420	Ball Seat, 9/32 Ball, C-22	61107	2	A, B, C, D, E,F
	420	Ball Seat, CA20	61439	2	G
	420	Ball Seat, 3/8 Ball, 316SS	61270	2	H
	422	Ball 9/32 Ceramic	35751	2	A, B, C, D, E,F
	422	Ball 9/32, CA20	41655	2	G
	422	Ball 3/8, 316SS	4070014112	2	H
424	Valve Body 1/4" NPT	36106	2	A, C, E, G, H	
424	Fitting, 1/4 PVDF	36081	2	B, D, F	

- Items not shown



PARTS LIST FOR D2 PLASTIC LIQUID END PVC, PVDF, BLACK POLY, H₂SO₄ AND POLYMER-NPT / PVC, PVDF AND BLACK POLY-TUBING. (CONT.)

FIGURE NUMBER	ITEM NUMBER	DESCRIPTION	PART NUMBER	QUANTITY PUMP	REFERENCE CODE
9	425	Check Valve Assembly, PVC / PVDF / BLACK PP - NPT	61141	2	A, C, E
	425	Check Valve Assembly, PVC / PVDF / BLACK PP - TUBE	61142	2	B, D, F
	426	Ball Cartridge	36113	2	A, B, C, E, F,G
	426	Ball Cartridge	36116	2	H
	427	Molded Washer, Cartridge Valve	36107	2	
	428	Spring, HAST-C	61275	2	H
	435	Coupling Nut, PP 3/8	10299	2	B, D, F
	445	Ferrule, 1/4" OD	28663	2	B, D, F
	-	Liquid End Kit, PVC / PVDF / BLACK PP	RPM 099	1	A, B, C, D, E,F
	-	Liquid End Kit, POLYMER	RPM 196	1	H

- Items not shown.

Illinois Location:
 (847) 841-7867
 860 Church Rd Elgin, IL 60

Minnesota Location:
 (651) 758-7867
 330 Mill Bay South Suite 1
 Afton, MN 55001

PumpSupplyInc.com

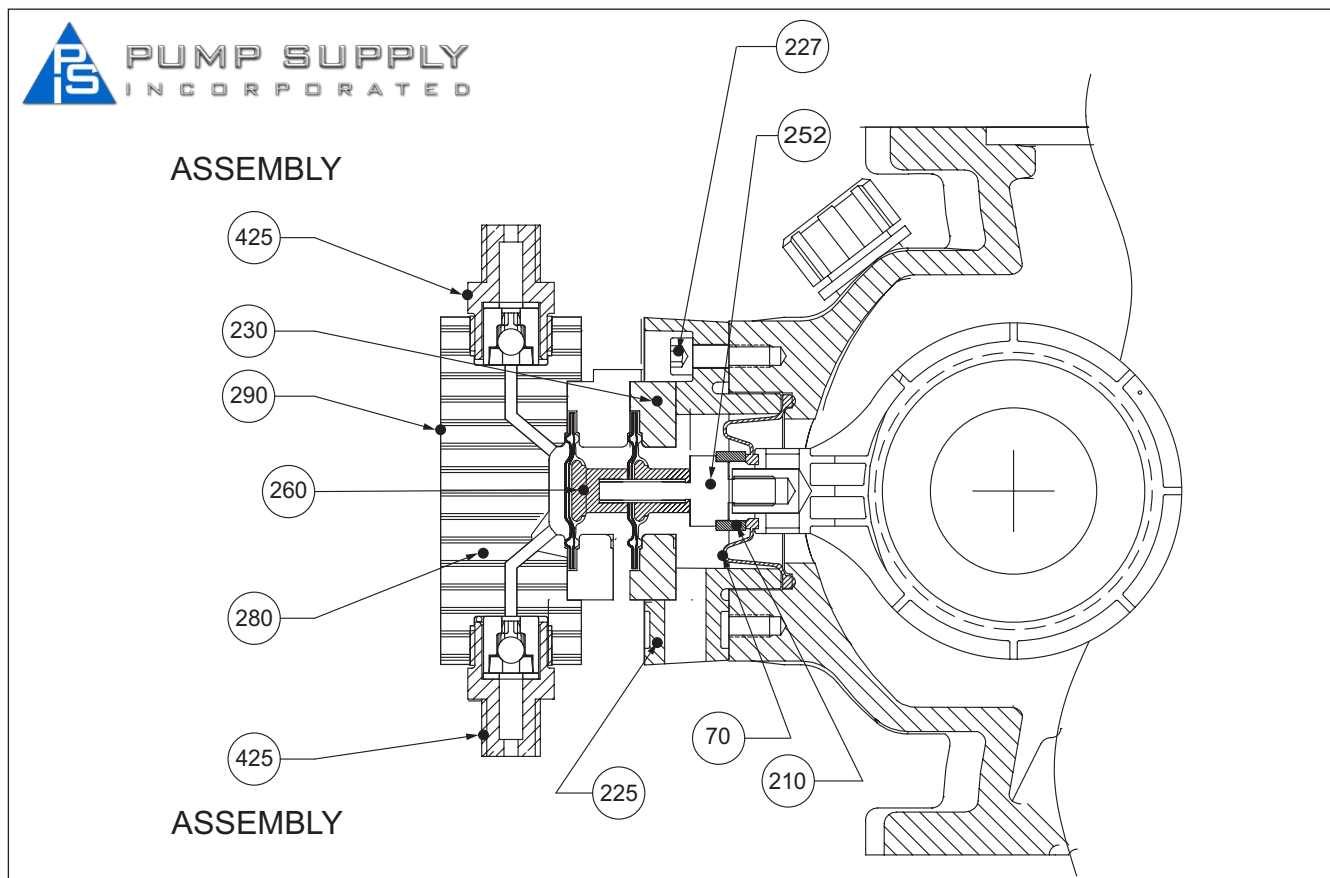

Figure 10. D2 Metallic Liquid End (102272800012)

5.3 PARTS LIST FOR D2 METALLIC LIQUID END STAINLESS STEEL-NPT

Model: D2 __ 7P

FIGURE NUMBER	ITEM NUMBER	DESCRIPTION	PART NUMBER	QUANTITY PUMP	REFERENCE CODE
10	70	Diaphragm / Oil Seal Bellows	60048	1	
	210	Oil Seal Clamp Ring	60043	1	
	225	Spacer	61035	1	
	227	Pan Head Screw, M6 X 20	70054	4	
	230	Diaphragm Seat Ring	61088	1	
	252	Adapter	61083	1	
	260	Diaphragm, PTFE	30916	1	
	280	Diaphragm Head	61106	1	
	290	Pan Head Screw, #10-24 X 3/4	61059	4	
	425	Check Valve Assembly - NPT	21082	2	
	-	Liquid End Kit, 316SS	RPM 101	1	

- Items not shown.

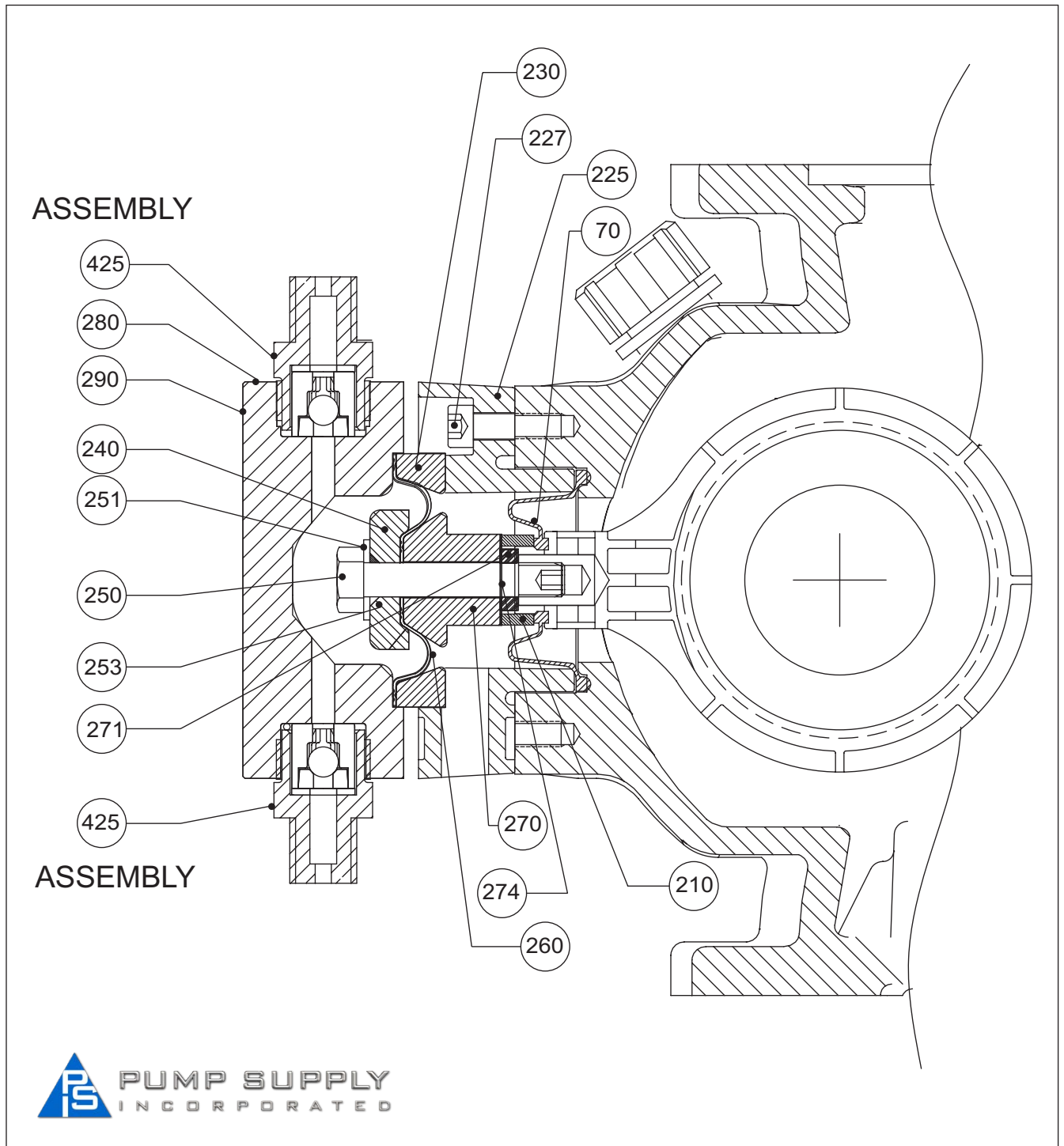

Figure 11. D4 Metallic Liquid End (10227280002)



5.4 PARTS LIST FOR D4 METALLIC LIQUID END STAINLESS STEEL-NPT

Model: D4 __ 7P ____ A (316SS)

FIGURE NUMBER	ITEM NUMBER	DESCRIPTION	PART NUMBER	QUANTITY PUMP	REFERENCE CODE
11	70	Diaphragm / Oil Seal Bellows	60048	1	
	210	Oil Seal Clamp Ring	60043	1	
	225	Spacer	61035	1	
	227	Pan Head Screw, M6 X 20	70054	4	
	230	Supporting Ring	61075	1	
	240	Diaphragm Cap, 316SS	61074	1	
	250	Hex Head Screw, M8 X 50, 316SS	61071	1	
	251	Washer, 8M, 316SS	61072	1	
	253	O-Ring, Viton	61073	1	
	260	Diaphragm, PTFE	60995	1	
	270	Support Nut, 316SS	61051	1	
	271	Hex Nut, M8 Thin	61054	1	
	274	PTFE Washer	61055	1	
	280	Diaphragm Head, 316SS	61070	1	
	290	Pan Head Screw, #10-24 X 3/4	61059	4	
	425	Check Valve Assembly	CV202294	2	
	-	Liquid End Kit, 316SS	RPM 104	1	

- Items not shown.

Illinois Location:
 (847) 841-7867
 860 Church Rd Elgin, IL 60

Minnesota Location:
 (651) 758-7867
 330 Mill Bay South Suite 1
 Afton, MN 55001

PumpSupplyInc.com

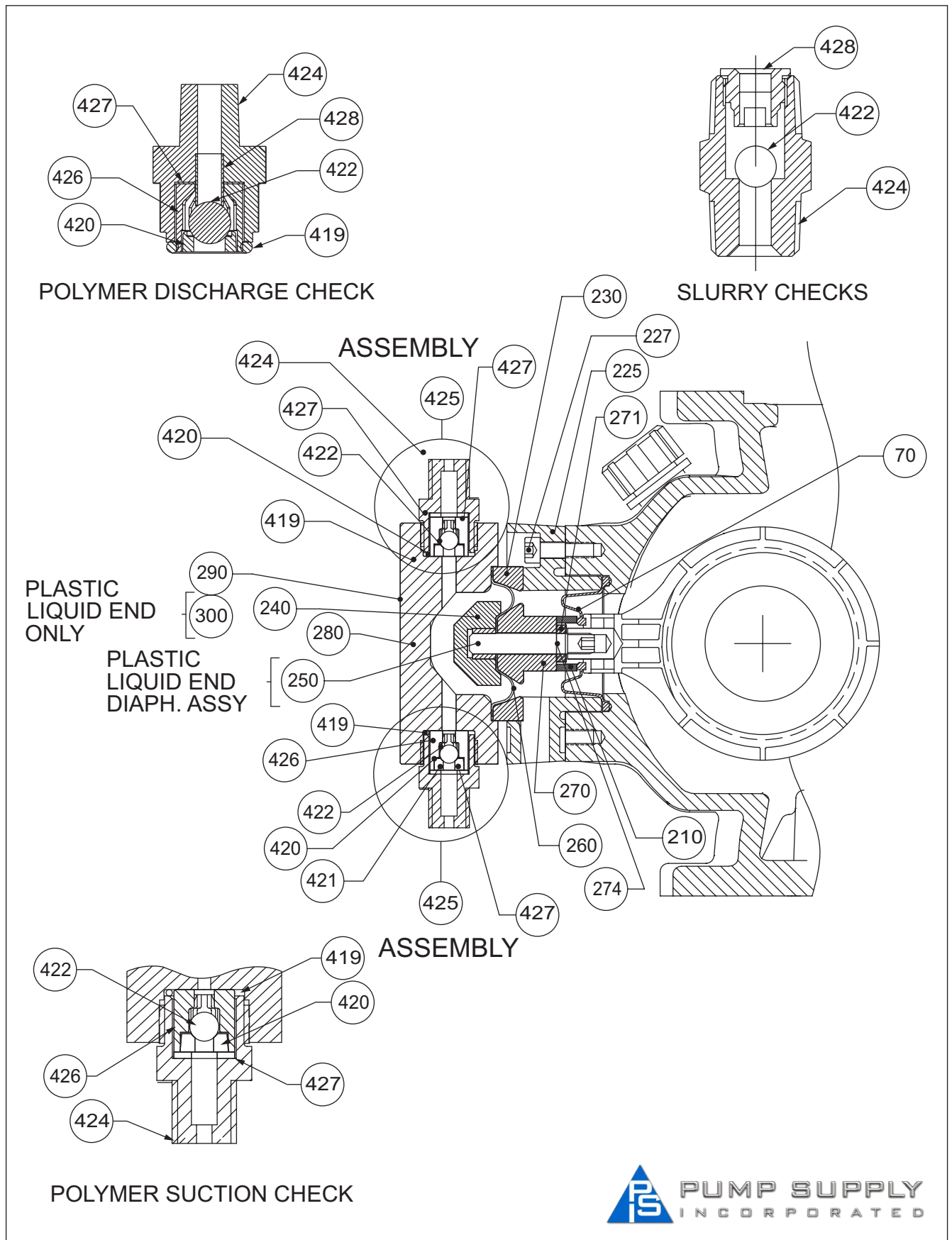

Figure 12. D4 Plastic Liquid End (10227280002)



5.5 PARTS LIST FOR D4 PLASTIC LIQUID END PVC, PVDF, BLACK POLY, H₂SO₄, SLURRY AND POLYMER- NPT / PVC, PVDF, BLACK POLY AND H₂SO₄-TUBING.

Model:	Reference Code:	Model:	Reference Code:
D4__ 8P _____	A (PVC NPT)	D4__ 4T _____	F (BLACK PP TUBE)
D4__ 8P _____	B (PVC TUBE)	D4__ NP _____	G (H2SO4 NPT)
D4__ 2P _____	C (PVDF NPT)	D4__ NT _____	H (H2SO4 TUBE)
D4__ 2T _____	D (PVDF TUBE)	D4__ PP _____	I (POLYMER)
D4__ 4P _____	E (BLACK PP NPT)	D4__ LP _____	J (SLURRY)

FIGURE NUMBER	ITEM NUMBER	DESCRIPTION	PART NUMBER	QUANTITY PUMP	REFERENCE CODE
12	70	Diaphragm / Oil Seal Bellows	60048	1	
	210	Oil Seal Clamp Ring	60043	1	
	225	Spacer	61035	1	
	227	Pan Head Screw, M6 X 20	70054	4	
	230	Diaphragm Support Ring	61075	1	
	240	Diaphragm Cap - PVC	61052	1	A, B, E, F, G, H, I
	240	Diaphragm Cap - 316SS	61074		J
	240	Diaphragm Cap - PVDF	61053	1	C, D
	250	Socket Set Screw, M8 X 50	61058	1	
	250	Socket Set Screw, M8 X 50, 316SS	61071	1	J
	253	O-Ring, 8MM ID, T=2MM, Viton	61073	1	J
	260	Diaphragm, PTFE	60995	1	
	270	Support Nut, 316SS	61051	1	
	271	Hex Nut, M8 X 50	61054	1	
	274	Washer, PTFE	61055	1	
	280	Diaphragm Head - PVC	61056	1	A, B, G, H, I
	280	Diaphragm Head - PVDF	61057	1	C, D
	280	Diaphragm Head - Black PP	61236	1	E, F
	280	Diaphragm Head - 316SS (SLURRY)	61070	1	J
	-	Decal	60534	1	
-	Decal, EAC Logo	2530118099	1		

- Items not shown.

Illinois Location:
 (847) 841-7867
 860 Church Rd Elgin, IL 60

Minnesota Location:
 (651) 758-7867
 330 Mill Bay South Suite 1
 Afton, MN 55001

PumpSupplyInc.com



PARTS LIST FOR D4 PLASTIC LIQUID END PVC, PVDF, BLACK POLY, H₂SO₄, SLURRY AND POLYMER- NPT / PVC, PVDF, BLACK POLY AND H₂SO₄-TUBING. (CONT.)

FIGURE NUMBER	ITEM NUMBER	DESCRIPTION	PART NUMBER	QUANTITY PUMP	REFERENCE CODE
12	290	Pan Head Screw, #10-24 X 3/4	61059	4	
	300	Flat Washer, #10 18.8SS	404000205	4	
	419	O-Ring, AFLAS	36103	2	E, F, G, H
	419	O-Ring, Viton	40905	2	I, J
	420	Ball Seat, 0.375, PTFE	39425	2	A, B, C, D, E, F
	420	Ball Seat, 3/8" Ball, CA-20	61316	2	G,H
	420	Ball Seat, 3/8" Ball, 316SS	61270	2	I
	421	O-Ring, AFLAS	39413	2	A, B, C, D, E, F
	422	Ball, 3/8" CERAMIC,+/- .001	10338	2	A, B, C, D, E, F
	422	Ball, 3/8" 316SS, Grade 50	4070014112	2	I
	422	Ball, 3/8" CA-20, Grade 50	4070014113	2	G,H
	422	Ball, 7/16" 316SS, P/O 22312, Item 425	CV102313	2	J
	424	Fitting, 1/4 PVDF - NPT	36106	2	E, G, I
	424	Fitting, 1/4 PVDF - TUBE	36081	2	F
	424	Fitting, 1/2 PVDF - TUBE	36138	2	H
	424	Check Valve Body, P/O 22312, Item 425	22313	2	J
	425*	Check Valve Assembly - NPT, 1/4"	36366	2	A, C
	425*	Check Valve Assembly - TUBE, 1/2"	36360	2	B, D
	425	Check Valve Assembly - PP	36306	2	E, F
	425	Check Valve Assembly - H2SO4	39461	2	G, H
	425	Check Valve Assembly - SLURRY	22312	2	J
	426	Cartridge, 0.375 PVDF	36116	2	E, F, G, H, I
	427	Washer	36107	2	E, F, G, H, I
-	Coupling Nut, 1/2"	10411	2	H	

- Items not shown

Illinois Location:
 (847) 841-7867
 860 Church Rd Elgin, IL 60

Minnesota Location:
 (651) 758-7867
 330 Mill Bay South Suite 1
 Afton, MN 55001

PumpSupplyInc.com



PARTS LIST FOR D4 PLASTIC LIQUID END PVC, PVDF, BLACK POLY, H₂SO₄, SLURRY AND POLYMER- NPT / PVC, PVDF, BLACK POLY AND , H₂SO₄-TUBING. (CONT.)

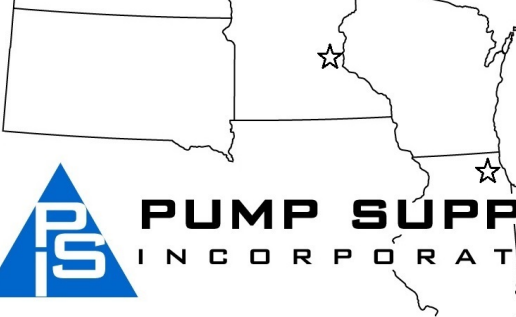

FIGURE NUMBER	ITEM NUMBER	DESCRIPTION	PART NUMBER	QUANTITY PUMP	REFERENCE CODE
12	428	Spring, Lee LC-016C-8-HAST-C, (Suction Only)	61275	1	I
	428	Retainer Sleeve	61071	1	J
	-	Coupling Nut	10299	2	F
	-	Ferrule, 1/4" OD	28663	2	F
	-	Liquid End Kit, PVC, PVDF, BLACK PP NPT / TUBE	RPM 102	1	A,B,C,D,E,F
	-	Liquid End Kit, H2SO4 NPT	RPM 173	1	G
	-	Liquid End Kit, H2SO4 TUBE	RPM 174	1	H
	-	Liquid End Kit, POLYMER	RPM 196	1	I
	-	Liquid End Kit, SLURRY	RPM 212	1	J

- Items not shown

Illinois Location:
(847) 841-7867
860 Church Rd Elgin, IL 60

Minnesota Location:
(651) 758-7867
330 Mill Bay South Suite 1
Afton, MN 55001

PumpSupplyInc.com

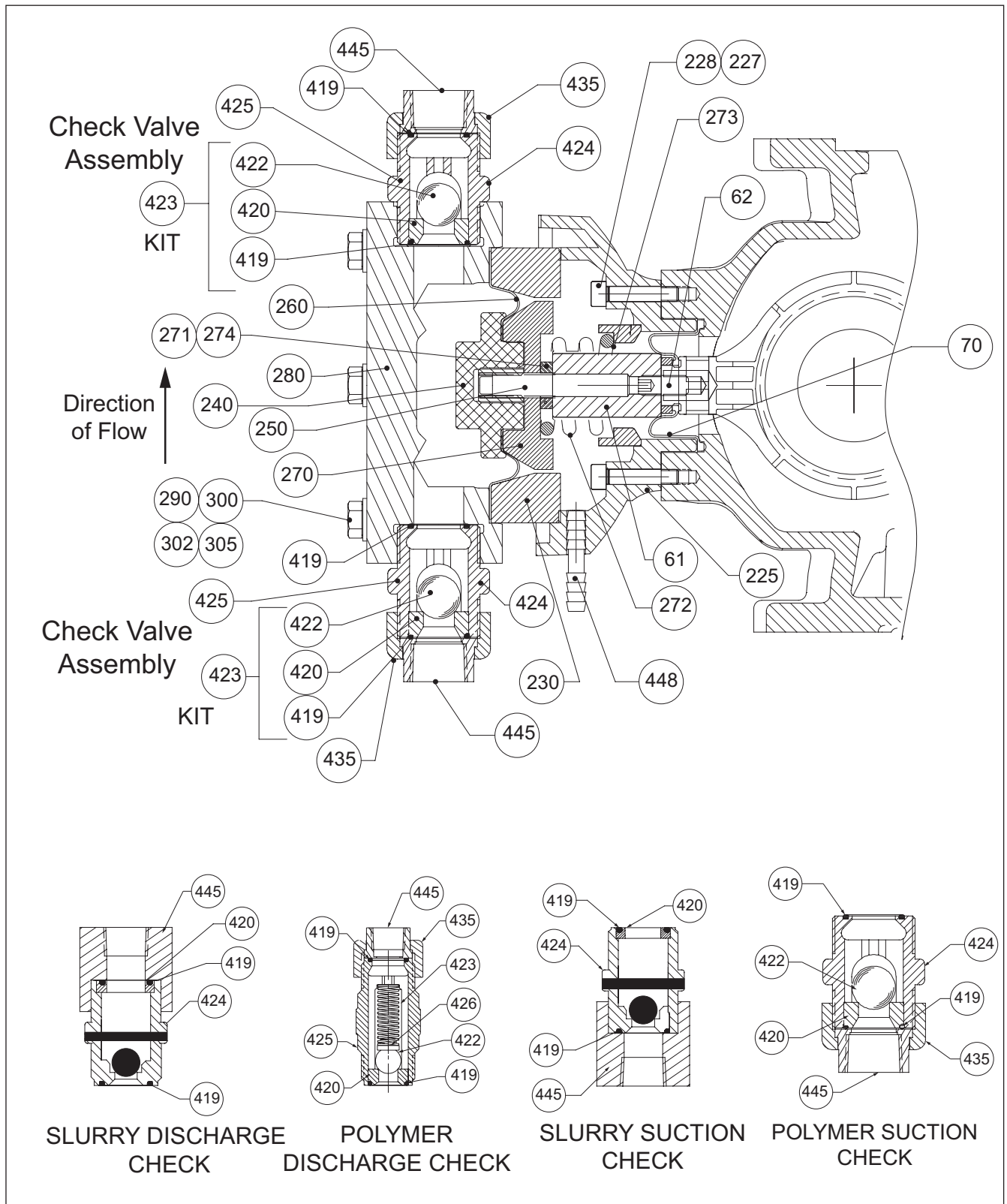

Figure 13. D7 & D8 Plastic Liquid End (1022819000)





5.6 PARTS LIST FOR D7 AND D8 PLASTIC LIQUID END PVC-NPT / TUBING, PVDF-NPT, BLACK POLYNPT, POLYMER-NPT, SLURRY-NPT & H₂SO₄-NPT.

Model: Reference Code:
 D7/D8__ 8P ____ A (PVC NPT)
 D7/D8__ 2P ____ B (PVDF NPT)
 D7/D8__ LP ____ C (SLURRY NPT)
 D7/D8__ NP ____ D (H2SO4 NPT)

Model: Reference Code:
 D7/D8__ PP ____ E (POLYMER NPT)
 D7/D8__ 4P ____ F (BLACK PP NPT)
 D7/D8__ 8T ____ G (PVC TUBE)

FIG. NO.	ITEM NO.	DESCRIPTION	D7 PART NO.	D8 PART NO.	QTY. PUMP	REFERENCE CODE
13	61	Adapter	61155	61155	1	
	62	Socket Head Set Screw, M8 X 20	4350016075N	4350016075N	1	
	70	Oil Seal Bellows	60048	60048	1	
	-	PTFE Seal Ring	61154	61154	1	
	225	Spacer	61156	61156	2	
	227	Socket Head Set Screw, M6 X 16, 304SS	4350003375N	4350003375N	2	
	228	Socket Head Set Screw, M6 X 30, 304SS	4350047395N	4350047395N	1	
	230	Diaphragm Support Ring	60035	60035	1	
	240	Diaphragm Cap - PVC	60628	60628	1	A, C, D, E,F, G
	240	Diaphragm Cap - PVDF	60630	60630	1	B
	250	Socket Set Screw, Dog PT M10 X 45	4350071284	4350071284	1	
	260	Diaphragm, PTFE	60618	60618	1	
	270	Support Nut	61065	61065	1	
	271	Hex Nut, M10 Thin, 316SS	61068	61068	1	
	272	Spring	70081	70081	1	
	273	Spring Cup	61153	61153	1	
	280	Head PVC	60033	60033	1	A, C, D, E,G
	280	Head PVDF	60031	60031	1	B
	280	Head Black Polypropylene	60882	60882	1	F
	281	Decal, Tighten MacRoy® Plastic	60534	60534	1	
282	Decal, EAC Logo	2530118099	2530118099	6		

- Items not shown.

* Items included as part of item number 425.



PARTS LIST FOR D7 AND D8 PLASTIC LIQUID END PVC-NPT / TUBING, PVDF-NPT, BLACK POLYNPT, POLYMER-NPT, SLURRY-NPT & H2SO4-NPT. (CONT.)

FIG. NO.	ITEM NO.	DESCRIPTION	D7 PART NO.	D8 PART NO.	QTY. PUMP	REFERENCE CODE
13	290	Hex Head Screw, M8 X 110mm, LG 304SS	4350001655	4350001655	6	
	300	Flat Washer, M8, Regular 304SS	4340005085	4340005085	1	A, B, C, D,E, G
	-	Back-up Plate	60754	60754	6	
	302	Split Washer M8, 304SS	4340009005	4340009005	6	
	-304	Nut Spacer	61152	61152	6	
	305	Hex Nut, M8, 304SS	4350000045	4350000045	4	
	419*	O-Ring, Viton, 2-117	4080068075	4080068075	4	A, C, D, E,F, G
	419*	O-Ring, PTFE, TEFLEX 2-117	40348	40348	2	B
	420*	Seat, PVDF	2240173078	2240173078	2	A, B, F, G
	420*	Slurry Seal Ring, 316SS	60819	60819	2	C
	420	Seat, 5/8" Ball 316SS	240173016	240173016	2	E
	420	Seat, 5/8" Ball CA20	60855	60855	2	D
	422	Ball, 14MM 316SS	60709	60709	2	C
	422*	Ball, 5/8 Ceramic	4070015171	4070015171	2	A, B, G
	422	Ball, 5/8 Ceramic	4070015171	4070015171	2	F
	422	Ball, 5/8 CA20	4070014173	4070014173	2	D
	422	Ball, 5/8 316SS	4070014172	4070014172	2	E
	422	Ball, 5/8 316SS		4070014172	2	F
	423	Spring, Hastelloy, (Discharge Only)	800123026	800123026	1	E
	423	Kit - Ball, Seat & O-Rings, PVC, Includes items 419, 420, and 422	3050879500	3050879500	2	A
	423	Kit - Ball, Seat & O-Rings, Includes items 419, 420, and 422	3050879700	3050879700	2	B
	423	Kit-Ball, Body, & Dowel Pin, Includes Items 422, 424 and 426	61238	61238	2	C
	424*	Cartridge Body, PVDF	60024	60024	2	A, B, D, E,F, G
424	Slurry Valve Body	30156071	30156071	1	E	

- Items not shown

* Items included as part of item number 425.





PARTS LIST FOR D7 AND D8 PLASTIC LIQUID END PVC-NPT / TUBING, PVDF-NPT, BLACK POLYNPT, POLYMER-NPT, SLURRY-NPT & H₂SO₄-NPT. (CONT.)

FIG. NO.	ITEM NO.	DESCRIPTION	D7 PART NO.	D8 PART NO.	QTY. PUMP	REFERENCE CODE
13	424	Ball Guide, PVC, Spring Loaded	60818	60818	2	C
	425	Check Valve Assembly, PVC, Includes Items 423 and 424	3050870007	3050870007	2	A
	425	Check Valve Assembly, PVDF Includes Items 423 and 424	3050870008	3050870008	2	B
	425	Check Valve Assembly, Slurry, Includes Items 419, 420 and 423	60827	60827	2	C
	-	Dowel Pin, 3/16 X 1.5, 416SS	60820	60820	2	C
	426	Poppet, PVDF	440090078	440090078	1	E
	435	Union Nut, 1/2" PVC	4320236038	4320236038	2	
	445	Union End, 1/2" NPT PVC	60117	60117	2	A, C, D,E, F, G
	445	Union End, 1/2" NPT PVDF	60119	60119	2	B
	-	Elbow 1" MPT X 1" BARB PVDF		61395	2	G
	-	Elbow 1/2" MPT X 1/2" BARB PVDF	61396		2	G
	448	Blow-Off Nozzle	470096073N	470096073N	1	
	-	Liquid End Kit, PVC-NPT / TUBE and Black PP NPT	RPM 135	RPM 105	1	A, F, G
	-	Liquid End Kit, PVDF NPT	RPM 136	RPM 106	1	B
	-	Liquid End Kit, Slurry NPT	RPM 215		1	C
	-	Liquid End Kit, Polymer NPT	RPM 211	RPM 210	1	E
	-	Liquid End Kit, H2SO4 NPT	RPM 175	RPM 183	1	D



- Items not shown.

* Items included as part of item number 425.

Illinois Location:
(847) 841-7867
860 Church Rd Elgin, IL 60

Minnesota Location:
(651) 758-7867
330 Mill Bay South Suite 1
Afton, MN 55001

PumpSupplyInc.com

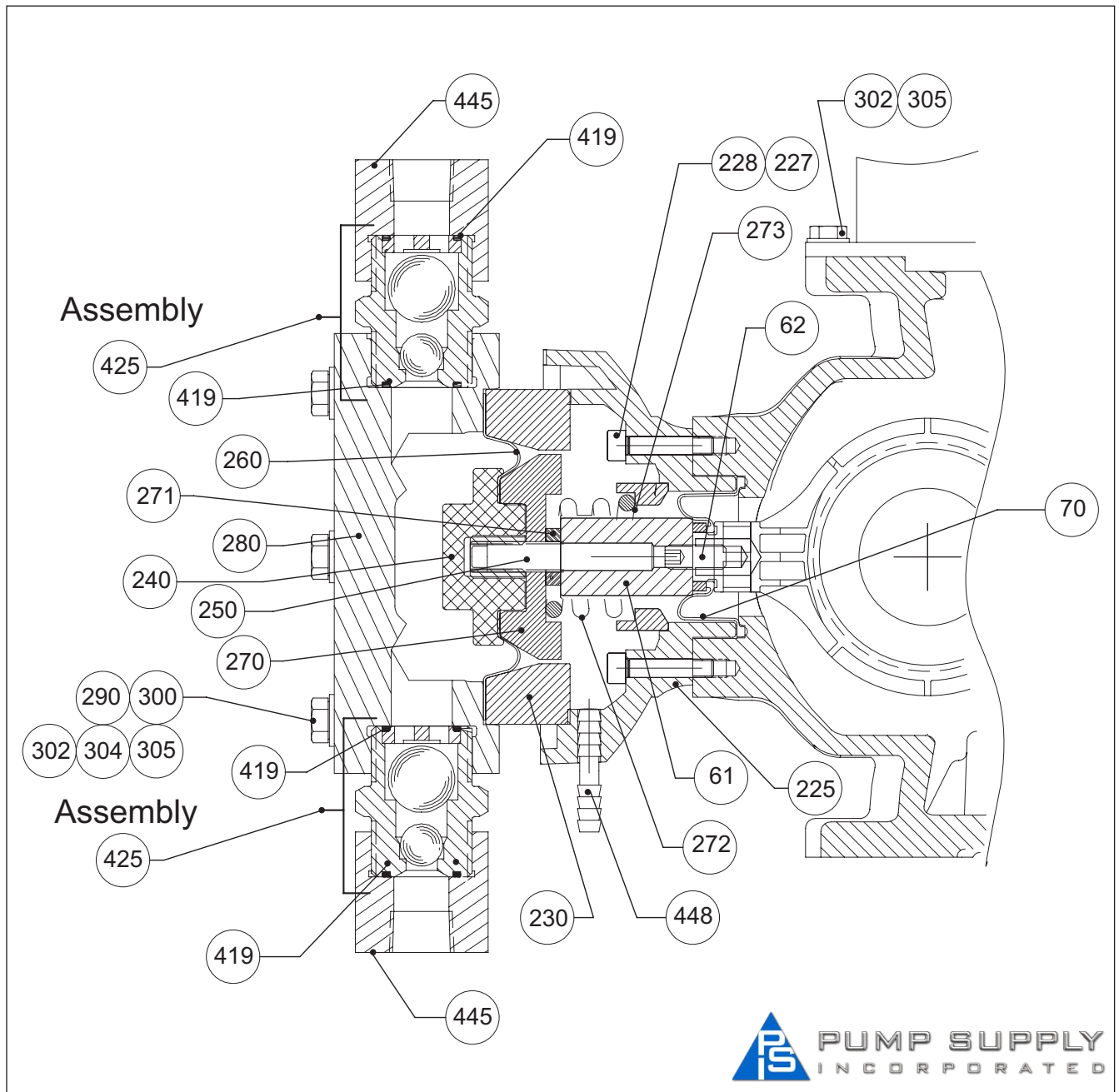



Figure 14. D7 & D8 316SS Liquid End (1022819000)

Illinois Location:
 (847) 841-7867
 860 Church Rd Elgin, IL 60

Minnesota Location:
 (651) 758-7867
 330 Mill Bay South Suite 1
 Afton, MN 55001

PumpSupplyInc.com



5.7 PARTS LIST FOR D7 AND D8 316SS-NPT LIQUID END

Model: D7 __ 7P _____ or D8 __ 7

FIG. NO.	ITEM NO.	DESCRIPTION	D7 PART NO.	D8 PART NO.	QTY. PUMP	REFERENCE CODE
14	61	Adapter	61155	61155	1	
	62	Socket Head Set Screw, M8 X 20	4350016075N	4350016075N	1	
	70	Oil Seal Bellows	60048	60048	1	
	210	PTFE Seal Ring	61154	61154	1	
	225	LE Adapter	61156	61156	1	
	227	Socket Head Set Screw, M6 X 16, 304SS	4350003375N	4350003375N	2	
	228	Socket Head Set Screw, M6 X 30, 304SS	4350047395N	4350047395N	2	
	230	Support Ring	60035	60070	1	
	240	Diaphragm Cap - 316SS	60631	60636	1	
	250	Socket Set Screw, Dog PT M10 X 45	4350071284	4350071284	1	
	260	Diaphragm, PTFE	60618	60624	1	
	270	Support Nut	61065	61146	1	
	271	Hex Nut, M10 Thin, 316SS	61068	61068	1	
	272	Spring	70081	70081	1	
	273	Spring Cup	61153	61153	1	
	280	Head, 316SS	210760016	61149	1	
	290	Hex Head Screw, M8 X 110mm, LG 304SS	4350001655	4350001655	6	
	300	Flat Washer, M8, Regular 304SS	4340005085	4340005085	6	
	302	Split Washer M8, 304SS	4340009005	4340009005	6	
	304	Nut Spacer	61152	61152	6	
	305	Hex Nut, M8, 304SS	4350000045	4350000045	6	
	419	O-Ring, 2-117 Viton	4080068075	4080068075	4	
	425	Check Valve Assembly	3050876602	3050876602	2	
445	Coupling, 1/2" NPT	60135	60135	2		
448	Blow-Off Nozzle	470096073N	470096073N	1		
-	RPM Kit, 316SS	RPM137	RPM107	1		

- Items not shown

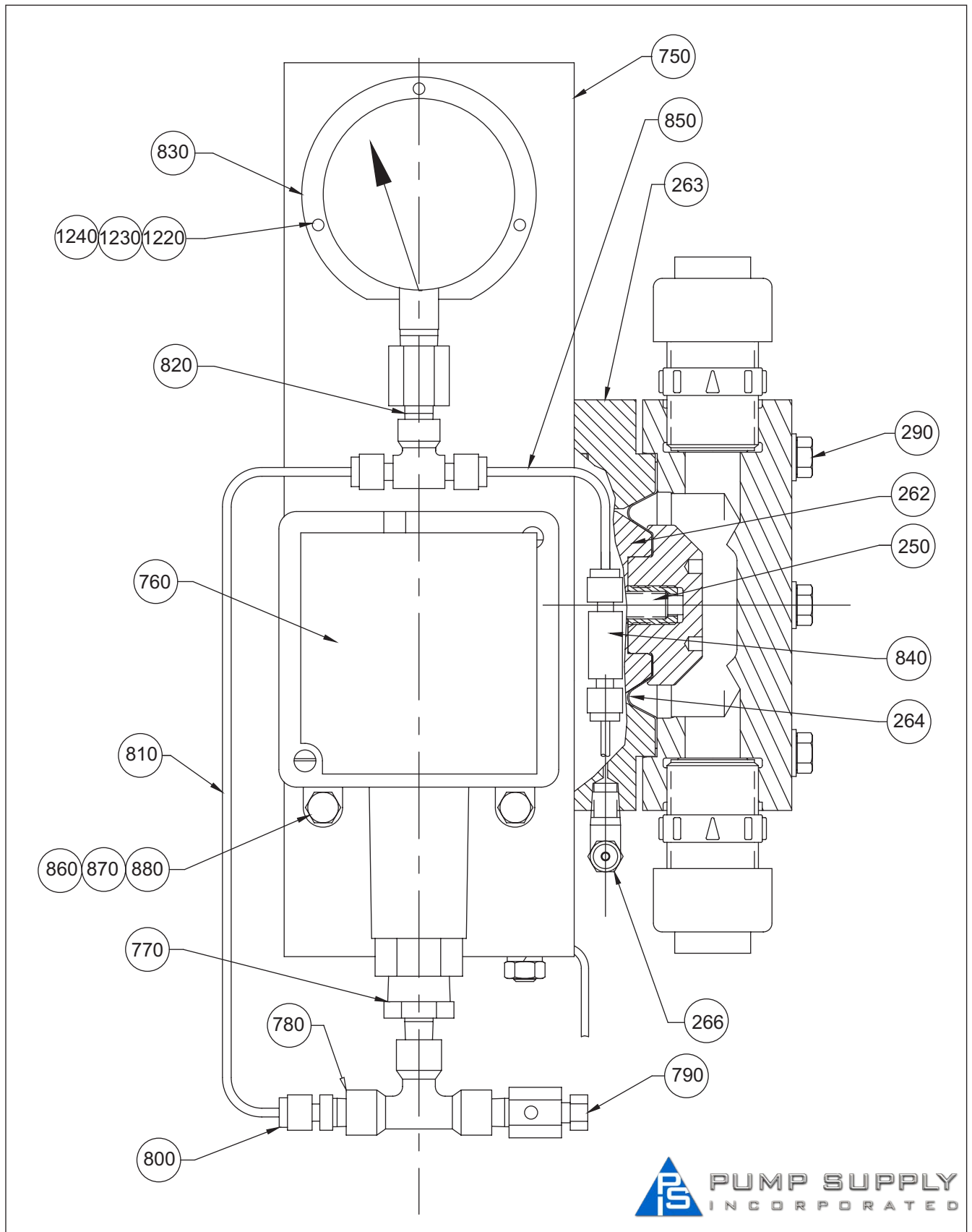

Figure 15. Leak Detection, Switch and / or Gauge (Optional) (10227280005)

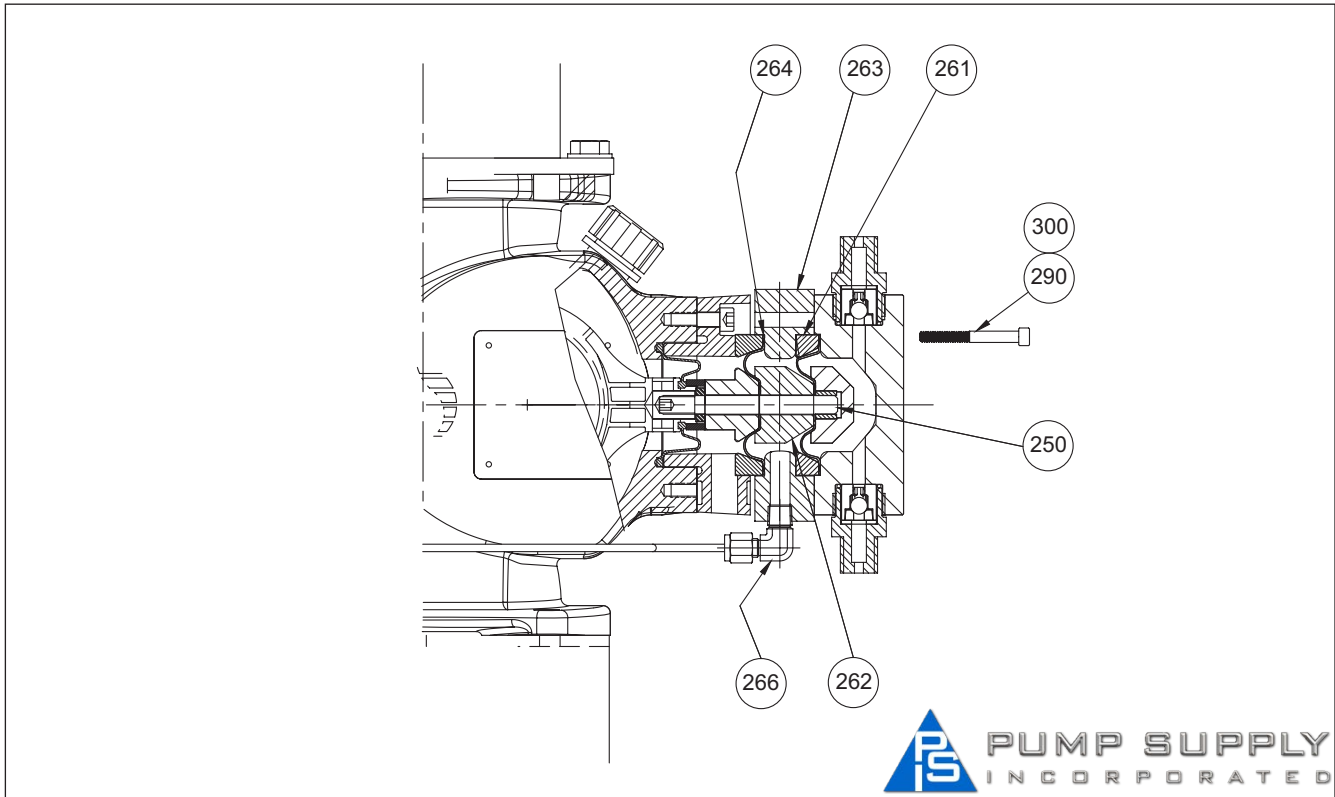

Figure 16. Double Diaphragm, D4 Pressure Type Configured (Optional) (10227280010)

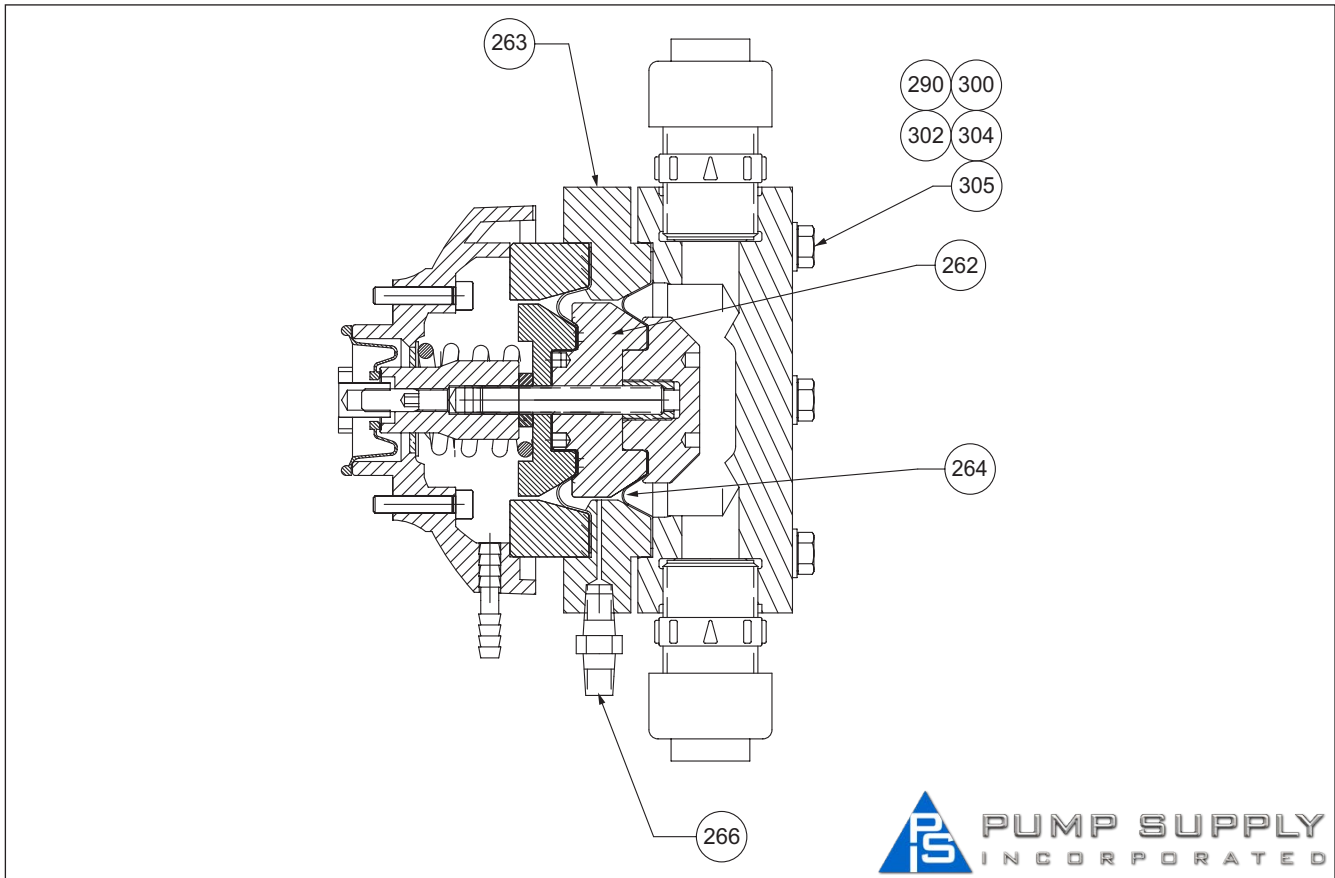

Figure 17. Double Diaphragm, D7 & D8 Pressure Type Configured (Optional) (10227280005)



5.8 LEAK DETECTION PARTS LIST

Model: Code:
 D2 _____ A
 D4 _____ B

Model: Code:
 D7 _____ C
 D8 _____ D

FIGURE NUMBER	ITEM NUMBER	DESCRIPTION	PART NUMBER	QUAN-TITY PUMP	REFERENCE CODE
15,16 & 17	250	Stud, Modified, 1/4 X 1-3/8	61379	1	A
	250	Set Screw, M8	61262	1	B
	250	Set Screw, Socket, Dog Pt. M10X70MM	4350071334	1	C, D
	252	Adapter, Double Diaphragm	61380	1	A
	261	Support Ring D4	61075	1	B
	262	Ring, Seat, Double Diaphragm	61386	1	A
	262	Spacer, Double Diaphragm, PVC	61258	1	B
	262	Spacer, Double Diaphragm, PVC	980367071	1	C
	262	Spacer, Double Diaphragm, PVC	980369071	1	D
	263	Ring, Spacer, Double Diaphragm	61256	1	B
	263	Ring, Intermed. - PVC	980366071	1	C
	263	Ring, Intermed. - PVC	980368071	1	D
	264	Diaphragm, PTFE	61381	1	A
	264	Diaphragm, PTFE	60995	1	B
	264	Diaphragm, PTFE	60618	1	C
	264	Diaphragm, PTFE	60624	1	D
	266	Connector, Male, 1/16 NPTM X 1/8 Tube	61378	1	A
	266	Nipple, Hex, 1/8NPT	40596	1	B
	266	Nipple, Hex, 1/4 NPT X 1/4 BSP	60208	1	C, D
	290	Screw, Panhead, 10-24 x 1-1/2	61385	4	A
290	Screw, Socket Head, #10 - 24 X 1-3/4	41069	4	B	

- Items not shown



**LEAK DETECTION PARTS LIST**

FIGURE NUMBER	ITEM NUMBER	DESCRIPTION	PART NUMBER	QUANTITY PUMP	REFERENCE CODE
15,16 & 17	290	Screw, Hex Head, M8 X 130 MM - 304SS	60206	6	C
	290	Screw, Hex Head, M8 X 140 MM - 304SS	61319	6	D
	300	Flat Washer, #10, 18.8SS, For PVDF Head	4040002053	4	A, B
	300	Flat Washer, M8, 304SS	4340005085	6	C, D
	302	Lock Washer, M8, 304SS	4340009005	6	C, D
	304	Spacer	61152	6	C, D
	305	Nut, M8, 304SS	4350000045	6	C, D
	750	Bracket	2040199006	1	
	760	Switch, NEMA 4 Pressure, 5 - 30 PSI	4060388001	1	
	760	Switch, NEMA 7 Pressure, 5 - 30 PSI	4060389001	1	
	770	Nipple, Reducing Hex 1/2 X 1/8 NPT	40064	1	
	780	Tee, 1/8 NPT Female, 316SS	40062	2	
	790	Valve, Bleed, 1/8 NPT, 316SS	40063	1	
	800	Connector, Tube, 1/8 TUBEX, NPT	40061	3	
	810	Tubing, Gauge to Switch	2490136016	1	
	820	Adapter, Reducing, 1/4F X 1/8M NPT	40067	1	
	830	Gage, Pressure, 0-400 PSI, (Dual Face)	40066	1	
	840	Check Valve, 1/8 Tube (1/3 PSI) - 316SS	40065	1	
	850	Tubing, Pump to Gauge - 316SS	2490137116	1	
	860	Screw, Hex Head, 1/4 - 20 X 3/4 18.8SS	4050016095	2	
870	Lock Washer, Spring, 1/4 - 18.8SS	4040039022	2		

- Items not shown





LEAK DETECTION PARTS LIST

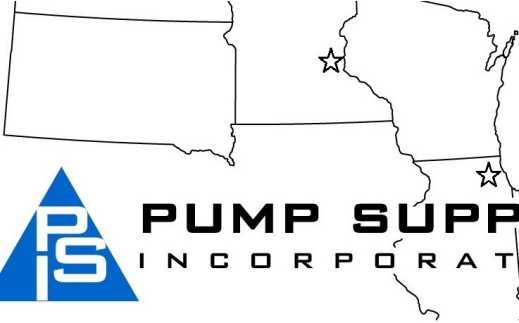

FIGURE NUMBER	ITEM NUMBER	DESCRIPTION	PART NUMBER	QUANTITY PUMP	REFERENCE CODE
15,16 & 17	880	Nut, Hex, 1/4-20 - 18.8SS	4050064012	2	A
	1220	Screw, Pan Head, #4-40 X 1/2	4050263050	3	
	1230	Lockwasher, Spring, #4, 18.8SS	4040095023	3	
	1240	Nut, Hex, #4 - 40, 18.8SS	4050182012	3	
	-	Liquid End Kit, PVC, PVDF, BLACK PP DD	RPM 161	1	A
	-	Liquid End Kit, 316SS, DD	RPM 162	1	A
	-	Liquid End Kit, PVC, PVDF, BLACK PP DD	RPM163	1	B
	-	Liquid End Kit, 316SS, DD	RPM 164	1	B

- Items not shown

Illinois Location:
 (847) 841-7867
 860 Church Rd Elgin, IL 60

Minnesota Location:
 (651) 758-7867
 330 Mill Bay South Suite 1
 Afton, MN 55001

PumpSupplyInc.com

PUMP SUPPLY
INCORPORATED

SECTION 6 - TROUBLESHOOTING

SYMPTOMS	POSSIBLE CAUSE	REMEDY
1. Pump motor won't operate	a) Low process liquid level in the tank.	a) Add liquid.
	b) Worn or dirty check valves.	b) Clean or replace.
	c) Blocked discharge line.	c) Clear line.
	d) Frozen liquid.	d) Thaw liquid throughout pumping system.
	e) Blown fuse	e) Replace fuse.
	f) Open thermal overload device in motor starter.	f) Reset device.
	g) Broken wire.	g) Locate and repair.
	h) Low voltage.	h) Investigate and correct (wiring may be too tight)
	i) Pump not primed	i) Allow suction line and pump head to fill with liquid before pumping against pressure.
	j) Capacity adjustment set at zero.	j) Readjust capacity.
2. Insufficient pump delivery.	a) Incorrect capacity adjustment.	a) Readjust capacity setting.
	b) Incorrect pump speed.	b) Match line voltage and frequency to pump motor data plate.
	c) Starved suction.	c) Increase piping size or suction head.
	d) Leaky suction piping.	d) Repair piping.
	e) High suction lift.	e) Rearrange equipment to decrease lift and / or install foot valve in suction line.
	f) Liquid near boiling.	f) Cool liquid or increase suction head.
	g) Leaky safety valve in discharge line.	g) Repair or replace valve.
	h) High liquid viscosity.	h) Reduce viscosity (e.g., heat or dilute liquid), or consult Milton Roy for a special check valve options.
	i) Worn or dirty check valve seats.	i) Clean or replace.
3. Erratic pump delivery	a) Leaky suction piping.	a) Repair piping.
	b) Leaky safety valve.	b) Repair or replace valve.
	c) Insufficient suction head.	c) Raise suction tank level and / or install foot valve in suction line.
	d) Liquid near boiling.	d) Cool liquid or increase suction head.
	e) Worn or dirty check valves.	e) Clean or replace.
	f) Clogged or dirty line strainer.	f) Clean strainer.

SYMPTOMS	POSSIBLE CAUSE	REMEDY
4. Motor and pump body hot	a) Normal operating temperature of both motor and pump body is frequently uncomfortable to the touch. However, neither should exceed 200°F (93°C).	a) N/A
	b) Power supply does not match electrical requirement of motor.	b) Insure proper matching of power supply and motor.
	c) Pump is being operated at greater than rated performance.	c) Reduce pressure or stroke speed. If this is not practical, contact service facility.
	d) Pump improperly lubricated.	d) Drain oil and refill with proper amount of recommended lubricant.
5. Pump still pumps even at zero capacity setting	a) Misadjusted capacity knob.	a) Readjust capacity setting.
	b) Insufficient discharge pressure.	b) Correct condition (e.g., install a back pressure valve).
6. Gear noise	a) Excessive backlash.	a) Consult service facility.
	b) Worn bearings.	b) Consult service facility.
	c) Wrong or insufficient lubricant.	c) Replace or replenish lubricant.
7. Loud knock with each stroke	a) Excessive gear set wear.	a) Consult service facility.
	b) Worn bearings.	b) Consult service facility.
8. Noisy operation in liquid end	a) Noise in check valves.	a) Ball checks move up and down with some force. A distinct "clicking" noise is normal, especially in metal piping systems.

Illinois Location:
 (847) 841-7867
 860 Church Rd Elgin, IL 60

Minnesota Location:
 (651) 758-7867
 330 Mill Bay South Suite 1
 Afton, MN 55001

PumpSupplyInc.com





PUMP SUPPLY
 INCORPORATED

Ingersoll Rand (NYSE:IR) advances the quality of life by creating comfortable, sustainable and efficient environments. Our people and our family of brands— including Club Car®, Ingersoll Rand®, Thermo King® and Trane®—work together to enhance the quality and comfort of air in homes and buildings; transport and protect food and perishables; and increase industrial productivity and efficiency. We are committed to a world of sustainable progress and enduring results.



Illinois Location:
(847) 841-7867
860 Church Rd Elgin, IL 60

Minnesota Location:
(651) 758-7867
330 Mill Bay South Suite 1
Afton, MN 55001

PumpSupplyInc.com

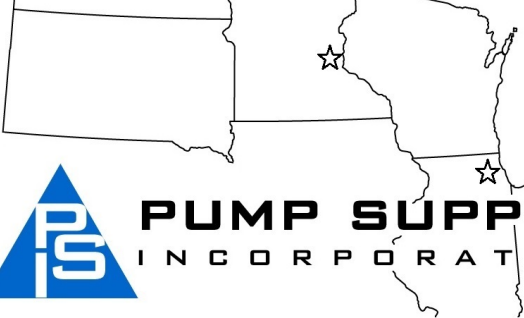
The logo for Pump Supply Incorporated, featuring a blue triangle with the letters 'PS' in white, followed by the text 'PUMP SUPPLY' in a bold, black, sans-serif font, and 'INCORPORATED' in a smaller, black, sans-serif font below it.

MacRoy® is a registered trademark of Milton Roy, LLC.
© 2019 Milton Roy, LLC.