

Product Manual | Installation, Parts & Maintenance

190-999 Rev H

WANNER™

HYDRA-CELL® PRO

METERING PUMP SOLUTIONS



Model MT8

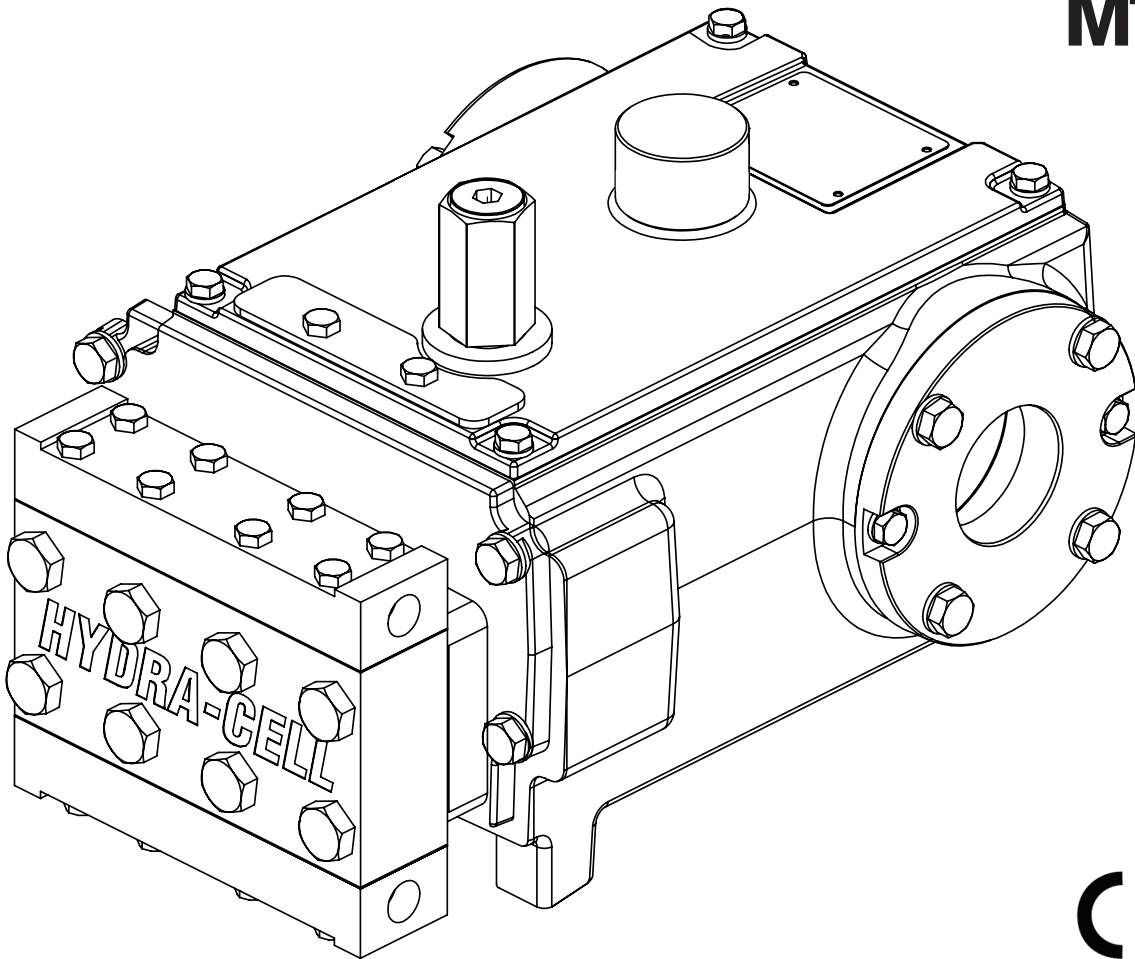

WANNER ENGINEERING, INC | HYDRA-CELL.COM

MT8 Contents



	Page
Operation	2
Specifications	2
Representative Drawings	5
Safety Precautions	6
Installation	7
Calibration	8
Maintenance	9
Fluid End Parts List	12
Hydraulic End Parts List	14
Drive End Parts List	15
Gearbox and Baseplate Parts List	17
Duplex Option	18
Manual Adjust Gearbox Parts List	19
Troubleshooting	20
Replacement Parts Kits	21
Manifold Pipe Plug Kits	21
Warranty	22

Component Identification

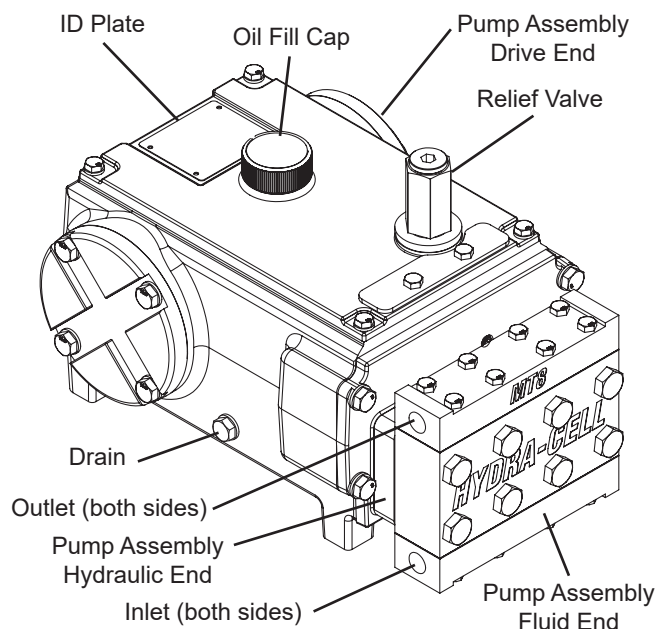

MT8 Operation

Hydra-Cell Metering Solutions Pumps are hydraulically actuated, hydraulically balanced diaphragm metering pumps that exceed API 675 performance standards of $\pm 1\%$ steady state accuracy, $\pm 3\%$ linearity and $\pm 3\%$ repeatability.

Due to their multiple diaphragm design, the MT Series metering pumps provide virtually “pulse-free” linear flow. Unlike conventional single diaphragm metering pumps, this linear flow reduces the need for pulsation dampeners and increases the reliability, performance, and safety of the metering pump system.

Pump operation and plunger activation are accomplished through a crankshaft.

MT Series pumps offer either mechanical flow adjustment or flow adjustment through a variable-frequency drive (VFD).

Pump pressure relief valve (54) is factory set to protect the pump from over pressurization. It is NOT to be used as a system pressure relief or regulator. Tampering with the relief valve will void manufacturer’s warranty.

Maximum flow rate listed on page 3 of IOM should not be exceeded. API flow compliance is rated up to 8 GPH (30.28 LPH). Running the pump at higher flow rates will not guarantee API flow compliance and could result in pump damage. Consult factory with questions regarding maximum flow rate.



MT8 Specification

Steady State Accuracy	$\pm 1\%$
Linearity	$\pm 3\%$
Repeatability	$\pm 3\%$
Maximum Discharge Pressure	
Metallic Heads:	3500 psi (241 bar)
Non-Metallic Heads:	350 psi (24 bar)
Maximum Inlet Pressure	
Metallic Heads:	500 psi (34 bar)
Non-Metallic Heads:	300 psi (21 bar)
Maximum Temperatures*	
Metallic Heads:	250°F (121°C)
Non-Metallic Heads:	140°F (60°C)
* Consult factory for correct component selection for temperatures from 160°F (71°C) to 250°F (121°C).	
Inlet Port	1/4 inch NPT or BSPT
Discharge Port	1/4 inch NPT or BSPT
Maximum Solids	200 microns
Suction Lift Capacity	20 feet (6.1 meters)
Shaft Rotation	Bi-directional
Oil Capacity	1-3/4 US quarts (1.7 liters)
Weight (less motor)	
Metallic Heads:	100 lbs (45.4 kg)
Non-Metallic Heads:	75 lbs (34 kg)
Flow Rate	0.06 - 8.0 GPH
Bolt Torque	See Pages 11,12,14,15,17,18



MT8 Specifications (Cont'd)

Performance Maximum Flow at Designated Pressure for Pumps with Electronic Gearbox Reducers - Imperial

Gearbox Part Number	All Pumps (gph)					Pump rpm	Gear Ratio	Motor rpm
	350 psi	500 psi	1500 psi	2500 psi	3500 psi			
112-400	0.479	0.473	0.429	0.387	0.349	18	100:1	1800
112-401	0.593	0.587	0.532	0.479	0.428	22.5	80:1	
112-402	0.784	0.776	0.703	0.635	0.567	30	60:1	
112-403	0.972	0.961	0.872	0.795	0.714	36	50:1	
112-404	1.189	1.177	1.089	0.985	0.888	45	40:1	
112-405	1.609	1.593	1.437	1.309	1.176	60	30:1	
112-407	2.336	2.312	2.105	1.924	1.727	90	20:1	
112-409	4.706	4.657	4.257	3.839	3.430	180	10:1	
112-410	6.218	6.156	5.556	5.064	4.464	240	7.5:1	
112-411	8.000*	8.000*	8.000*	7.320*	6.530*	360	5:1	

Required Motor hp: 1/2

* Flow rates above 8 gph not guaranteed to meet API 675 Performance Standards; therefore, pump speed should be limited to 315 rpm at 350 psi and 352 rpm at 1500 psi when using a 5:1 gear reducer and 1800 rpm motor. To reach 8 gph at pressures above 1700 psi with the same reducer and motor, the VFD will need to be programmed for operation above 60 Hz.

Performance Maximum Flow at Designated Pressure for Pumps with Electronic Gearbox Reducers - Metric

Gearbox Part Number	All Pumps (lph)					Pump rpm	Gear Ratio	Motor rpm
	24 bar	34 bar	103 bar	172 bar	241 bar			
112-400	1.567	1.492	1.353	1.221	1.101	15	100:1	1500
112-401	1.945	1.852	1.678	1.511	1.350	18.75	80:1	
112-402	2.570	2.448	2.218	2.003	1.789	25	60:1	
112-403	3.183	3.031	2.751	2.508	2.252	30	50:1	
112-404	3.899	3.713	3.435	3.107	2.801	37.5	40:1	
112-405	5.276	5.025	4.533	4.129	3.710	50	30:1	
112-407	7.658	7.293	6.640	6.069	5.448	75	20:1	
112-409	15.426	14.691	13.429	12.110	10.820	150	10:1	
112-410	20.390	19.419	17.526	15.974	14.082	200	7.5:1	
112-411	30.092*	28.659*	25.810*	23.091*	20.598*	300	5:1	

Required Motor kW: 0.37

* Flow rates above 30.28 lph are not guaranteed to meet API 675 Performance Standards. To reach a flow rate of 30.28 lph with a 5:1 gear box and 1500 rpm motor, the VFD will need to be programmed for operation above 50 Hz.

Note: Systems vary. The MT8 pump must be calibrated once installed to ensure optimum performance. The API 675 Performance Standard is achievable for flow rates as low as 0.06 gph (or 0.2271 lph). Please contact the factory for assistance.

Illinois Location:

(847) 841-7867

860 Church Rd Elgin, IL 60120

Minnesota Location:

(651) 758-7867

330 Mill Bay South Suite
Afton, MN 55001

PumpSupplyInc.com



190-999 Rev H

MT8 Specifications (Cont'd)



Performance Maximum Flow at Designated Pressure for Pumps with Manual Variable Speed Gearbox

Flow Rates in Gallons Per Hour (gph)

Manual Dial Setting	All Pumps		Metallic Pump Heads Only								Motor rpm
	350 psi		500 psi		1500 psi		2500 psi		3500 psi		
	Flow Rate	rpm	Flow Rate	rpm	Flow Rate	rpm	Flow Rate	rpm	Flow Rate	rpm	
1	1.85	70	1.85	71	1.62	70	1.44	70	1.28	70	1800
2	3.67	144	3.64	144	3.62	143	2.92	143	2.62	143	
3	5.56	213	5.51	214	4.90	213	4.40	212	3.93	211	
4	7.26	280	7.16	281	6.36	278	5.70	278	5.09	277	
5					7.75	343	6.94	342	6.17	341	
6									7.08	405	
Manual Dial Setting to achieve Maximum Flow Rate at pressures shown above											
	4.45		4.50		5.17		5.87		6.90		Motor pm
	8.00	310	8.00	315	8.00	354	8.00	399	8.00	462	1800

Required Motor hp: 1/2

- Minimum flow rate of 0.06 gph can be achieved at a Manual Dial setting of 0.1.
- Flow rates above 8 gph are not guaranteed to meet API 675 Performance Standards.
- Only use motors 1/2 hp with turndown ratios to match the appropriate range of application.

Flow Rates in Liters Per Hour (lph)

Manual Dial Setting	All Pumps		Metallic Pump Heads Only								Motor rpm
	24 bar		34 bar		103 bar		172 bar		241 bar		
	Flow Rate	rpm	Flow Rate	rpm	Flow Rate	rpm	Flow Rate	rpm	Flow Rate	rpm	
1	5.99	60	5.98	61	5.24	60	4.63	59	4.04	59	1500
2	11.53	121	11.39	121	10.21	120	9.24	120	8.11	120	
3	17.62	179	17.21	179	15.46	178	13.94	178	12.27	177	
4	23.04	234	22.64	235	20.31	233	18.28	232	16.12	231	
5	28.22	288	27.86	289	24.97	286	22.36	286	19.73	285	
6							26.09	339	23.23	338	
7							29.95	392	26.24	391	
8									29.59	444	
Manual Dial Setting to achieve Maximum Flow Rate at pressures shown above											
	5.42		5.50		7.00		7.10		8.10		Motor pm
	30.28	310	30.28	315	30.28	355	31.28	397	30.28	448	1500

Required Motor kW: 0.37

- Minimum flow rate of 0.227 lph can be achieved at a Manual Dial setting of 0.1.
- Flow rates above 30.28 lph are not guaranteed to meet API 675 Performance Standards.
- Only use motors 0.37 kW with turndown ratios to match the appropriate range of application.





MT8 Representative Drawings

Units of Measure: Inches (mm)

Metallic Pump Heads

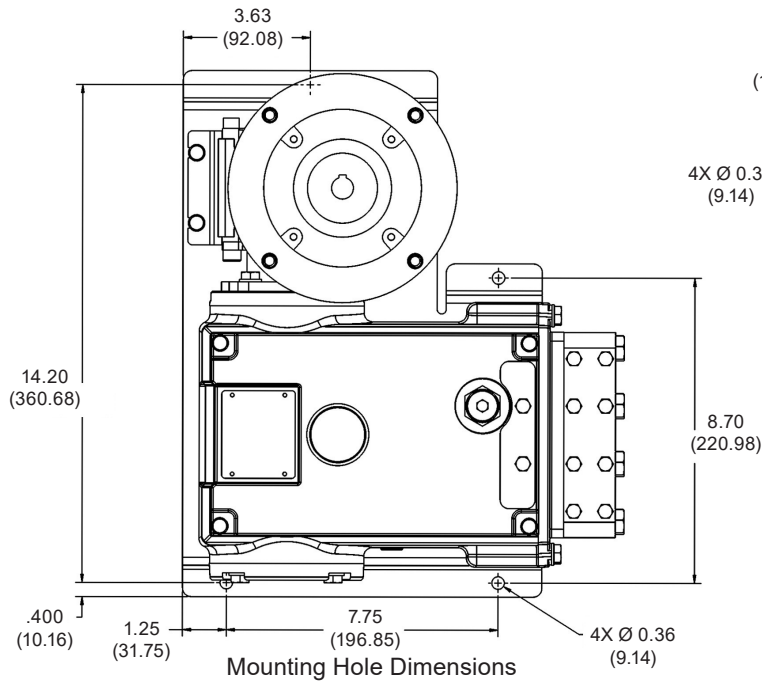

Metallic Heads with Manual Adjustment

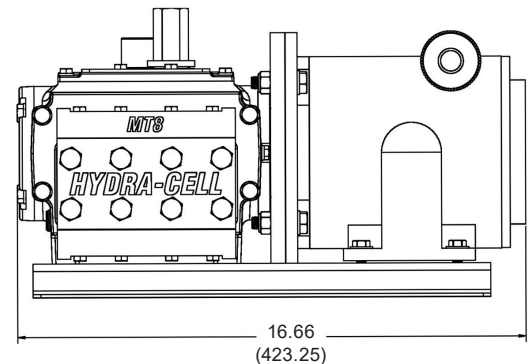
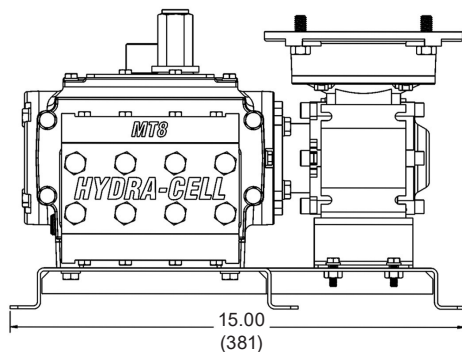
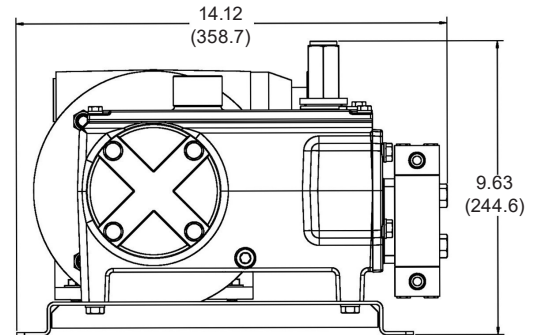
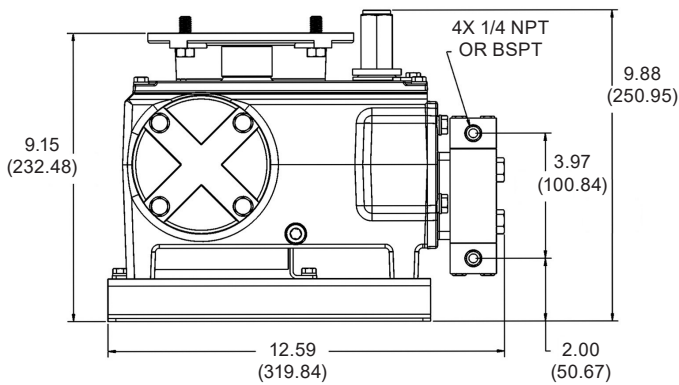
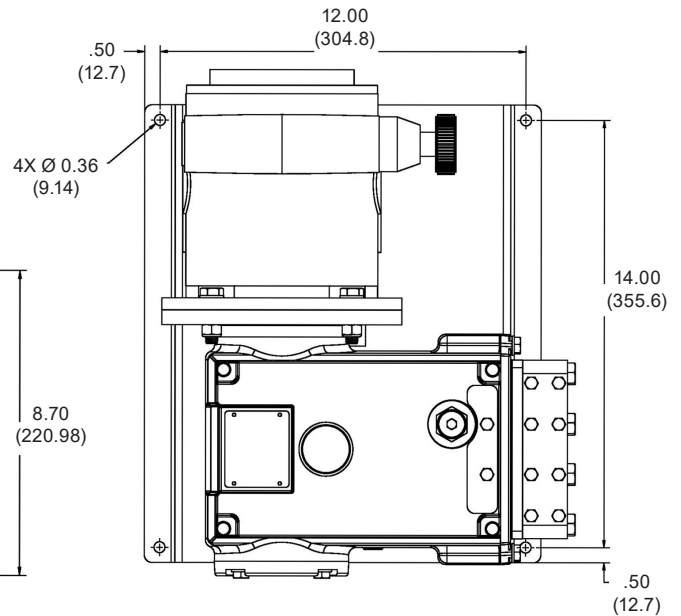

Note: These drawings are to be used for reference only. All dimensions are reference. Contact factory for additional drawings of specific models and configurations.



Safety Precautions

General Remarks

These safety / installation instructions contain fundamental information and precautionary notes and must be kept available to all associated with the operation of the pump. Please read them thoroughly prior to installation, electrical connection and commissioning of the unit. It is imperative that all other operating instructions relating to the components of individual units are followed.

These safety / installation instructions do not take local regulations into account. The operator must ensure that such regulations are observed by all, including the personnel carrying out the installation.

Each pump must be labeled by the end user to warn of any hazards that the system process may produce; e.g. corrosive chemicals or hot process etc.

All personnel involved in the operation, maintenance, inspection and installation of the pump must be fully qualified to carry out the work. The personnel's responsibilities, competence and supervision must be clearly defined by the operator. To the extent that if the personnel in question is not already in possession of the requisite know how, appropriate training and instruction must be provided. In addition, the operator is responsible for ensuring that the contents of the operating instructions are fully understood by all the responsible personnel.

When installing a Hydra-Cell pump in conjunction with a motor or motor and frequency controller the relevant manuals must be referred to for electromagnetic compatibility. The installation should conform to EN 61800 and EN 60204 as applicable.

All safety instructions in this manual and all relevant local health and safety regulations must be followed.

Attention must be paid to the weight of the pump before either lifting it manually or by selecting appropriate lifting equipment.

Inlet Piping

Provide for permanent or temporary installation of a compound pressure gauge to monitor the inlet pressure. To maintain maximum flow, the pump inlet should be under flooded suction conditions at all times. **Do not supply more than one pump from the same inlet line.**

Supply Tank

Use a supply tank that is large enough to provide time for any trapped air in the fluid to escape. The tank size should be at least twice the maximum pump flow rate.

Install a separate inlet line from the supply tank to each pump.

Place a cover over the supply tank, to prevent foreign objects from falling into it.

Hose Sizing and Routing

To minimize acceleration head and frictional losses, size the suction line at least one size larger than the pump inlet, and keep the suction line as short and direct as possible.

Recommendations:

- Keep inlet lines less than 3 ft. (1 m) long
- Use at least 3/8" (9 mm) I.D. inlet hose
- Minimize fittings (elbows, valves, tees, etc.)

Support the pump and piping independently.

Inlet Piping (Pressure Feed)

Provide for permanent or temporary installation of a compound pressure gauge to monitor the inlet pressure. To maintain maximum flow, the pump inlet should be under flooded suction conditions at all times. **Do not supply more than one pump from the same inlet line.**

Note: System back pressure must exceed the pump inlet pressure by at least 15 psi (1 bar) in order to prevent flow thru.

Discharge Piping

Hose and Routing

Use the shortest, most-direct route for the discharge line.

Select pipe or hose with a working pressure rating of at least 1.5 times the maximum system pressure. Example: Select a 1500 psi (103 bar) W.P. rated hose for a system to be operated at 1000 psi (69 bar) gauge pressure.

Support the pump and piping independently.

Pressure Regulation

Install a pressure relief valve in the discharge line. Bypass pressure must not exceed the pressure limit of the pump.

Size the valve so that, when fully open, it will be large enough to relieve the full capacity of the pump without over pressurizing the system.

Locate the valve as close to the pump as possible and ahead of any other valves. Adjust the pressure relief valve to no more than 10% over the maximum working pressure of the system. Do not exceed the manufacturer's pressure rating for the pump or valve.

Route the bypass line to the supply tank.

CAUTION: Never install shutoff valves in the bypass line or between the pump and pressure regulator or relief valve.

Provide for permanent or temporary installation of a pressure gauge to monitor the discharge pressure at the pump.

Minimum Discharge Pressure

To ensure proper capacity control, a minimum discharge pressure of 50 psi (3.5 bar) is required.



MT8 Installation

Location

Locate the pump as close to the supply source as possible.

Install the pump system in a lighted clean space where it will be easy to inspect and maintain.

Motor and Controller

The MT Series pump shaft can rotate in either direction, therefore direction of motor shaft rotation is not critical.

When flow rate is determined by motor speed, it is controlled using an inverter duty constant torque motor and VFD. Flow rate functions can also be easily controlled using the Hydra-Cell Control Freak and appropriate motor or by selecting the manual adjust option.

Accessories

Consult installation drawing below for typical metering fluid system components. Contact Wanner Engineering or the distributor in your area for more details.



Illinois Location:

(847) 841-7867

860 Church Rd Elgin, IL 60123

Minnesota Location:

(651) 758-7867

330 Mill Bay South Suite 1511 Afton, MN 55001

PumpSupplyInc.com

Important Precautions

Adequate Fluid Supply. To avoid cavitation and premature pump failure, be sure that the pump will have an adequate fluid supply and that the inlet line will not be obstructed.

Positive Displacement. This is a positive-displacement pump. Although the MT Series pump is equipped with the patented Diaphragm Position Control and internal relief system, it is recommended that an external pressure relief valve be installed downstream of the pump to avoid severe system damage if the discharge line ever becomes blocked.

Safety Guards. Follow all codes and regulations regarding installation and operation of the pumping system.

Shut-Off Valves. Never install shut-off valves between the pump and discharge pressure regulator or in the regulator bypass line.

Consult the Factory in the following situations:

- Extreme temperature applications (above 160°F or below 40°F)
- Ambient temperatures (above 110°F)
- Pressure feeding of pumps
- Viscous or abrasive fluid applications
- Chemical compatibility problems

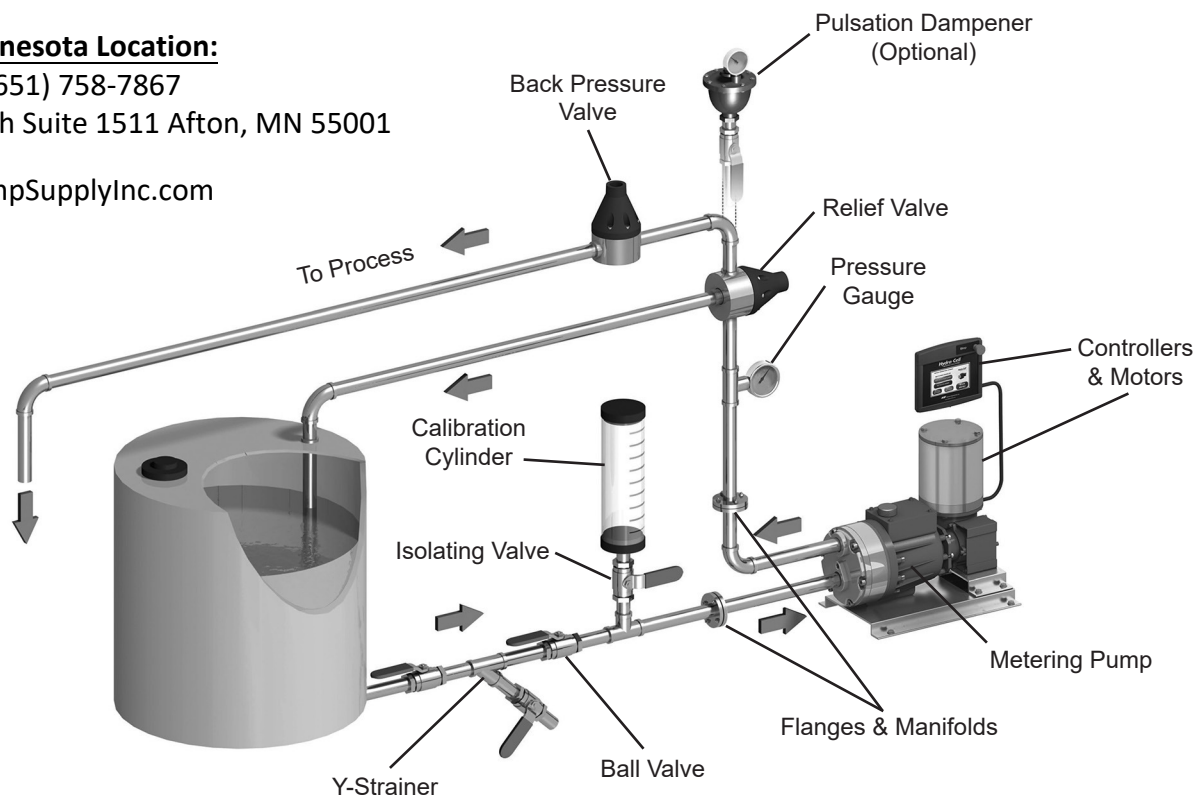



MT8 Installation (Cont'd)

Initial Start-Up Procedure

Before you start the pump, be sure that:

1. All shut-off valves are open, and pump has adequate supply of fluid.
2. All connections are tight.
3. The oil level is 1 in. (25 mm) from the top of the crankcase.
4. Open priming valve on system back pressure valve so pump starts under minimum pressure. See Typical Metering Installation drawing.
5. Be sure unused manifold ports are properly plugged.
Refer to **page 20** for appropriate plug kit.

Turn on power to pump motor and:

1. Check inlet pressure. To maintain maximum flow, pump inlet should be under flooded suction conditions at all times. Inlet pressure must not exceed 250 psi (17.3 bar).
2. Observe any erratic noise or flow.
3. Jog pump on and off until fluid coming from priming valve is air-free.
4. Close priming valve.
5. Perform pump calibration. See Calibration Procedure.

Tips for Priming

Do not inspect the diaphragms

This is often the first impulse, but it should only be the last resort. Disassembling the pump to inspect the diaphragms will cause a loss of prime in the hydraulic (power) end. A diaphragm repair kit will then be needed to replace the PTFE components.

Increase motor speed

Gearboxes with a ratio of 30:1 or higher tend to have more priming issues. In such cases, "overspeed" the motor—starting at 200 revolutions per minute (rpm) or more—so that the pump speed is approximately 150 revolutions per minute (rpm).

Alternatives to increasing motor speed

1. Start and stop the pump.
2. While the pump is running, remove the main pressure relief valve (PRV) to see if any air became entrapped in the hydraulic end during shipping.
3. Temporarily install a priming pump to feed the MT8 until it primes.

Different check valve materials

Wanner Engineering has determined that the inability to prime is because the PTFE O-rings inside the check valve are not sealing.

Contact factory for internal check valve O-rings in another material:

FKM (Viton®) – We will supply test check valves with FKM O-rings at no cost.

FFKM (Kalrez®) – We consider FFKM O-rings a good option for high gearbox ratios. Due to the expense of FFKM, however, there will be a cost.

Checklist of other solutions

- Do not try to prime against system pressure.
- Do not open any bypass valves.
- Make sure that the inlet conditions are proper, including NPSH.
- If priming outdoors, the pump temperature must be above 40 F (4.4 °C)
- Verify that the pump shaft is turning by removing the oil cap to view the crankshaft.
- The main PRV must be in place, or no fluid will pump.
- If it sounds like the gearbox is making a knocking sound, and the flow rate is low, then air is entrapped in the fluid end of the pump. (It is not the gearbox regardless of the sound.)

Calibration

Note: Each metering pump or pump system must be calibrated to determine the pump speed required for the desired flow rate.

Accurate calibration depends on pump discharge pressure and system conditions. When calibrating the pump or system, it is useful to plot capacity curves for future reference. Observe on the curve, that pump capacity decreases slightly as discharge pressure increases.

In order to achieve the best possible results, perform calibration under actual process conditions. Follow these steps:

1. Run pump for 20 minutes at actual process conditions. If process system cannot be used, circulate back to supply tank through pressure relief valve (see Typical Metering Installation drawing). If required system pressure is less than 50 psi (3.5 bar), a back pressure valve must be installed and set to produce minimum of 50 psi (3.5 bar) pressure at pump head.
2. Determine maximum pump speed required for all system conditions that need to be satisfied. Measure pump delivery at this maximum speed using system calibration cylinder, flow meter, or similar container. This is the "rated capacity" for pump.
3. Measure pump delivery at 100%, 75%, 50%, 25%, and 10% of maximum speed just determined. Let pump run for 5 minutes at each speed setting or manual adjust setting before taking capacity measurement.



Illinois Location:

(847) 841-7867

860 Church Rd Elgin, IL 60123

Minnesota Location:

(651) 758-7867

330 Mill Bay South Suite 1511 Afton, MN 55001

PumpSupplyInc.com

MT8 Maintenance



Periodically

CAUTION: Do not turn the drive shaft while the oil reservoir is empty.

CAUTION: Do not leave contaminated oil in the pump housing or leave the housing empty. Remove contaminated oil as soon as discovered and replace with clean oil.

1. Check inlet pressure periodically with gauge.
2. Change oil annually.
3. Change oil as follows:
 - a. Remove drain plug (60), and allow oil and contaminants to drain completely. Catch oil and dispose of properly. Reinstall drain plug.
 - b. Add suitable oil for the application and pump components.
 - c. Ensure oil level is 1 in. (25 mm) from the top crankcase.
4. Oil Capacity 1-3/4 US quarts (1.7 liters).

Change Oil Annually

Note: Minimum oil viscosity for proper hydraulic end lubrication is 16-20 CST (80-100 SSU). MT Series replacement parts kits (complete kits and diaphragm kits) include suitable oil for each MT Series pump configuration.

CAUTION: If you are losing oil but don't see any external leakage, or if the oil becomes discolored and contaminated, the diaphragm (18) may be damaged. Refer to the Fluid End Service and Troubleshooting Sections. Do not operate the pump with a damaged diaphragm.



Illinois Location:

(847) 841-7867

860 Church Rd Elgin, IL 60123

Minnesota Location:

(651) 758-7867



330 Mill Bay South Suite 1511 Afton, MN 55001

PumpSupplyInc.com

Illinois Location:
(847) 841-7867
860 Church Rd Elgin, IL 60123

Minnesota Location:
(651) 758-7867
330 Mill Bay South Suite :
Afton, MN 55001

PumpSupplyInc.com

PUMP SUPPLY
INCORPORATED



MT8 Maintenance (Cont'd)

This section explains how to disassemble and inspect all easily serviceable parts of the pump.

CAUTION: Disassembly of the hydraulic end of the pump should be performed only by a qualified technician. For assistance, contact Wanner Engineering (612-332-5681) or the distributor in your area.

When flow rate is determined by motor speed, it is controlled using an inverter duty constant torque motor and VFD. Flow rate functions can also be easily controlled using the Hydra-Cell Control Freak and appropriate motor or by selecting the manual adjust option.

CAUTION: If the pump is losing oil and no external leakage is visible, or if the oil becomes discolored and contaminated, the single diaphragm may be damaged.

IMPORTANT: Fluid such as engine oil, hydraulic fluid, coolants, grease, etc. must be disposed of in an environmentally safe manner. Some regulations require that certain spills and leaks on the ground must be cleaned in a specific manner. See local, state and federal regulations for the correct disposal method.

1. Changing Hydraulic End Oil

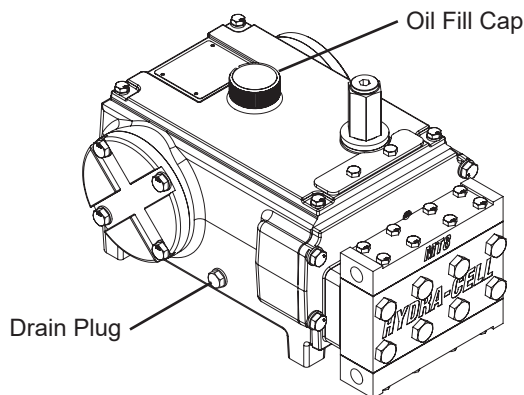

- If necessary, with the pump horizontal, remove drain plug and oil fill cap (56) (D03-039-1250). Allow all oil and contaminant to drain out.

Note: MT Series replacement parts kits (complete kits and diaphragm kits) include the correct oil for each specific MT Series pump configuration.

- Install drain plug.

CAUTION: Do not leave contaminated oil in the pump housing or leave the housing empty.

- Fill the reservoir per the specification table on page 2. Contact Wanner Engineering (612-332-5681) for more details.

Illinois Location:

(847) 841-7867

860 Church Rd Elgin, IL 60123

Minnesota Location:

(651) 758-7867

330 Mill Bay South Suite 1511 Afton, MN 55001

PumpSupplyInc.com

2. Hydraulic End Priming

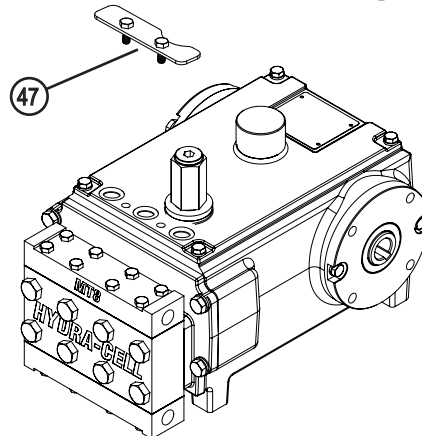

- Remove PRV port plate (Item 47) (190-047) exposing the three air bleed valve assemblies (Item 34) (190-901).

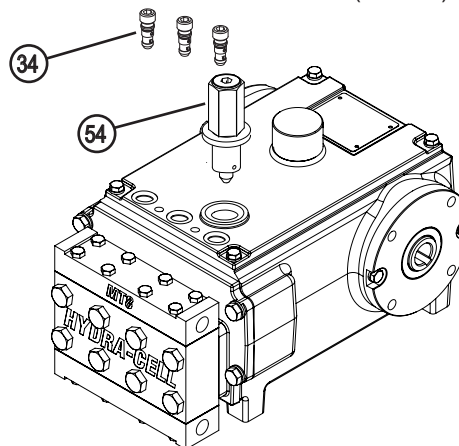

- Remove all three air bleed valve assemblies (Item 34) (190-901) and main PRV relief assembly (Item 54) (190-058).

- Using a pipette, drizzle oil from crankcase into all three air bleed valve assembly ports until full.

- Set motor control or manual adjust gearbox to no more than 50 pump RPM.

- Turn on motor.

- Bubbles will be observed coming from all three air bleed valve ports. Allow pump to run until no more bubbles are observed coming from ports. Oil may need to be added to one or more of the air bleed valve ports during this phase.

NOTE: DO NOT re-install main relief valve assembly.

- Once all three air bleed valve assemblies have been reinstalled, re-start pump. Bubbles will be observed coming from main relief valve port.

IMPORTANT: Run pump for a minimum of 10 minutes, or until no more bubbles can be seen escaping from main relief valve assembly port (this may take much longer than 10 minutes, but this step is crucial to making sure all the air is removed from hydraulic end of pump).

- Stop the pump.

- Re-install the main PRV assembly.

MT8 Maintenance (Cont'd)



3. Diaphragm Installation

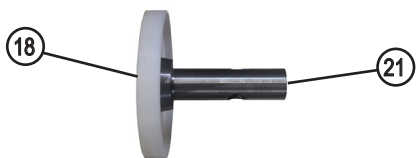

- a. Assemble diaphragm followers (21) (190-072) onto the diaphragms (18) (190-018-07) hand tight.

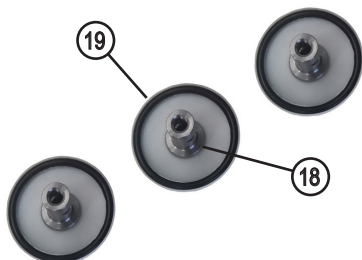

- b. Install one o-ring (19) (190-050-10) onto back side of diaphragms (18) (190-018-07).

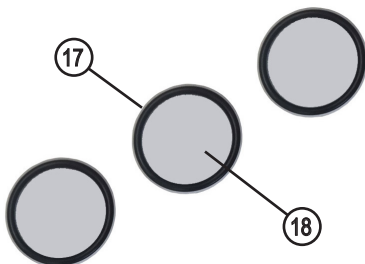

- c. Install one o-ring (17) (190-050-11) onto front of each diaphragm (18) (190-018-07).



- d. Seat each of the three diaphragm / O-ring assemblies into the diaphragm backer plate (20) (190-421) as shown.

4. Fluid End Service

CAUTION: If the bolts (6) that hold the manifold body (4) / (10)* in place are loosened or removed, a diaphragm kit will need to be ordered and installed because the diaphragms (18) will no longer seal properly and will need to be replaced.

CAUTION: If the bolts (2) / (16)* that hold the top manifold (1) / (13)* or bottom manifold (5) / (12)* in place are loosened or removed in order to inspect the check valves, then O-rings (7), O-rings (8) and crush rings (9) will all need to be replaced for the check valves to seal and function properly.

*For non-metallic pump heads

5. Maintenance Videos

Videos for Priming, Diaphragm Replacement and Check Valve Replacement.

<https://www.youtube.com/watch?v=UeM4y3-AcSk>

(Fluid End Priming)

<https://www.youtube.com/watch?v=Hgq-ghOcSVw>

(Hydraulic End Priming)

<https://www.youtube.com/watch?v=UbChCrUkb7U>

(Diaphragm Replacement)

<https://www.youtube.com/watch?v=Uh30nwD0KC8>

(Check Valve Replacement)





MT8 Fluid End Parts List

Metallic Pump Head

Non-metallic Pump Head

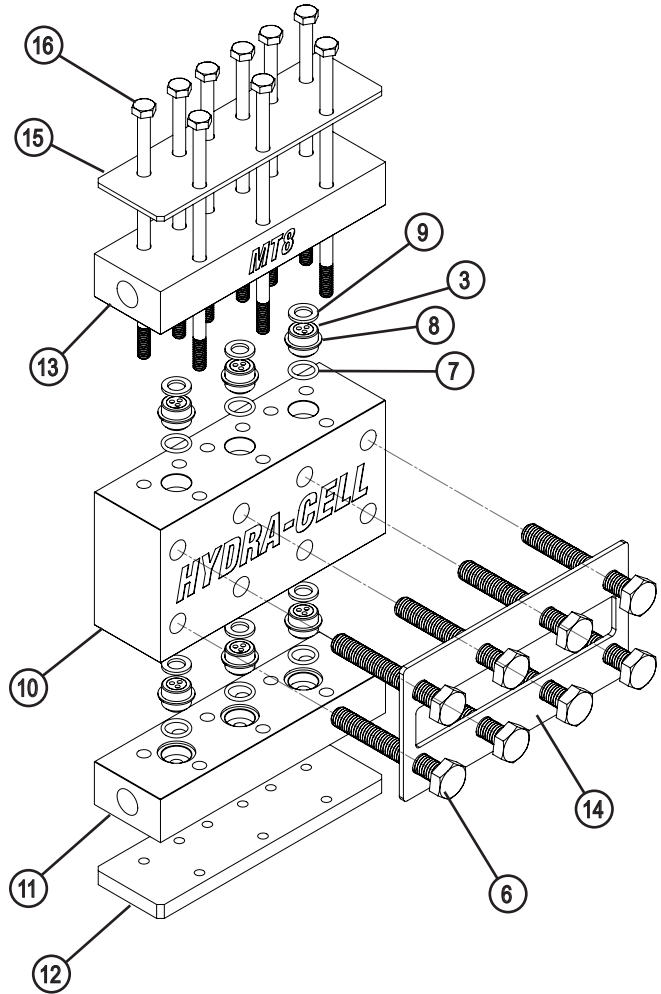
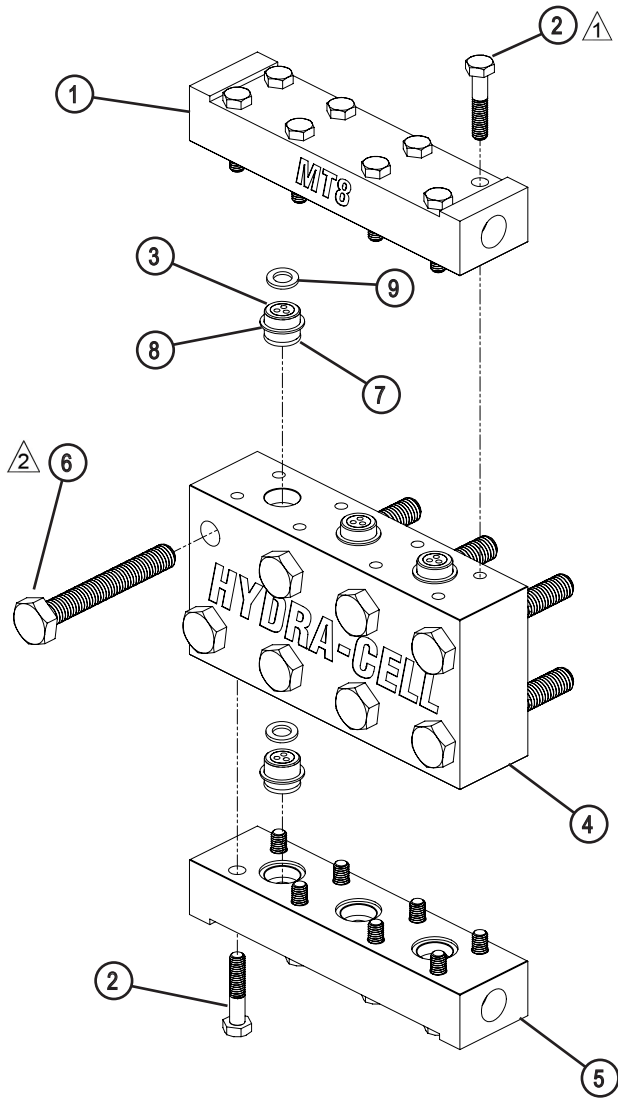

- ⚠ TORQUE TO 10 ± 2 FT/LBS
- ⚠ TORQUE TO 45 ± 3 FT/LBS

NOTE: For non-metallic pump heads, when torquing bolts do not over tighten! Torque until no gap remains between Items 10, 13, 11 & 20.



MT8 Fluid End Parts List (Cont'd)

Ref. No.	Part Number	Description	Quantity/ Pump
1	190-260-01	Manifold Top, 316 SST, NPT	1
	190-260-02	Manifold Top, Hastelloy, NPT	1
	190-260-03	Manifold Top, Alloy 20, NPT.....	1
	190-260-06	Manifold Top, 316 SST, BSPT.....	1
	190-260-07	Manifold Top, Hastelloy, BSPT.....	1
	190-260-08	Manifold Top, Alloy 20, BSPT	1
2	190-300	Bolt, Hex Head, M6	16
3	190-905-01	Check Valve Assembly, 316 SS	6
	190-905-02	Check Valve Assembly, Hastelloy C ...	6
	190-905-03	Check Valve Assembly, Alloy 20.....	6
4	190-258-01	Manifold Body, 316 SST.....	1
	190-258-02	Manifold Body, Hastelloy.....	1
	190-258-03	Manifold Body, Alloy 20.....	1
5	190-259-01	Manifold Bottom, 316 SST, NPT	1
	190-259-02	Manifold Bottom, Hastelloy, NPT	1
	190-259-03	Manifold Bottom, Alloy 20, NPT	1
	190-259-06	Manifold Bottom, 316 SST, BSPT	1
	190-259-07	Manifold Bottom, Hastelloy, BSPT	1
	190-259-08	Manifold Bottom, Alloy 20, BSPT.....	1
6	190-302	Bolt, Hex Head, M10	8
7	190-301	O-ring, PTFE	6
8	D40-047-2114	O-ring, PTFE Encapsulated	6
9	190-261	Ring, Crush, PTFE	6
10	190-110-01	Manifold, Body, PVC	1
	190-110-02	Manifold, Body, PVDF	1
11	190-111-01	Manifold, Bottom, PVC, 1/4" NPT	1
	190-111-02	Manifold, Bottom, PVDF, 1/4" NPT	1
	190-111-03	Manifold, Bottom, PVC, 1/4" BSPT	1
	190-111-04	Manifold, Bottom, PVDF, 1/4" BSPT	1
12	190-117	Plate, Manifold Bottom	1
13	190-112-01	Manifold, Top, PVC, 1/4" NPT	1
	190-112-02	Manifold, Top, PVDF, 1/4" NPT	1
	190-112-03	Manifold, Top, PVC, 1/4" BSPT	1
	190-112-04	Manifold, Top, PVDF, 1/4" BSPT	1
14	190-113	Plate, Manifold Front	1
15	190-114	Plate, Manifold Top.....	1
16	190-115	Bolt, HHCS, M6 18-8 SS	9



Illinois Location:

(847) 841-7867

860 Church Rd Elgin, IL 60123

Minnesota Location:

(651) 758-7867

330 Mill Bay South Suite 1511 Afton, MN 55001

PumpSupplyInc.com

MT8 Hydraulic End Parts List



Ref. No.	Part Number	Description	Quantity/ Pump
17	190-050-11	O-ring, PTFE	3
18	190-018-07	Diaphragm, MT8 Single	3
19	190-050-10	O-ring, BUNA	3
20	190-421	Plate, Diaphragm Backer	1
21	190-072	Follower, Diaphragm	3
22	190-028	Spring	3
23	190-022	Guide, Washer	3
24	190-032	Screw, PHMS, M5	3
25	190-009	Spool Valve	3
26	190-904	Washer, Underfill Valve	3
27	190-906	Assembly, Underfill Valve	3
28	177-905	Assembly, Overfill Valve	3
29	190-096	Bolt, Hex Head, M8	4
30	190-093	Washer, M8	4

Ref. No.	Part Number	Description	Quantity/ Pump
31	190-003-02	Hydraulic Plate	1
32	190-099	Plug, 1/16-27 NPT	2
34	190-901	Assembly, Air Bleed Valve	3
35	190-038	O-ring, FKM	3
36	C63-010-2111	O-ring, FKM	3
37	190-108	Backup Ring	3

Hydraulic End Service

CAUTION: Disassembly of the hydraulic end of the pump should be performed only by a qualified technician. For assistance, contact Wanner Engineering (612-332-5681) or the distributor in your area.

1 TORQUE TO 20 ± 2 FT/LBS

2 TORQUE TO 8 ± 1 FT/LBS



Illinois Location:

(847) 841-7867

860 Church Rd Elgin, IL 60123

Minnesota Location:

(651) 758-7867

330 Mill Bay South Suite 1511 Afton, MN 55001

PumpSupplyInc.com

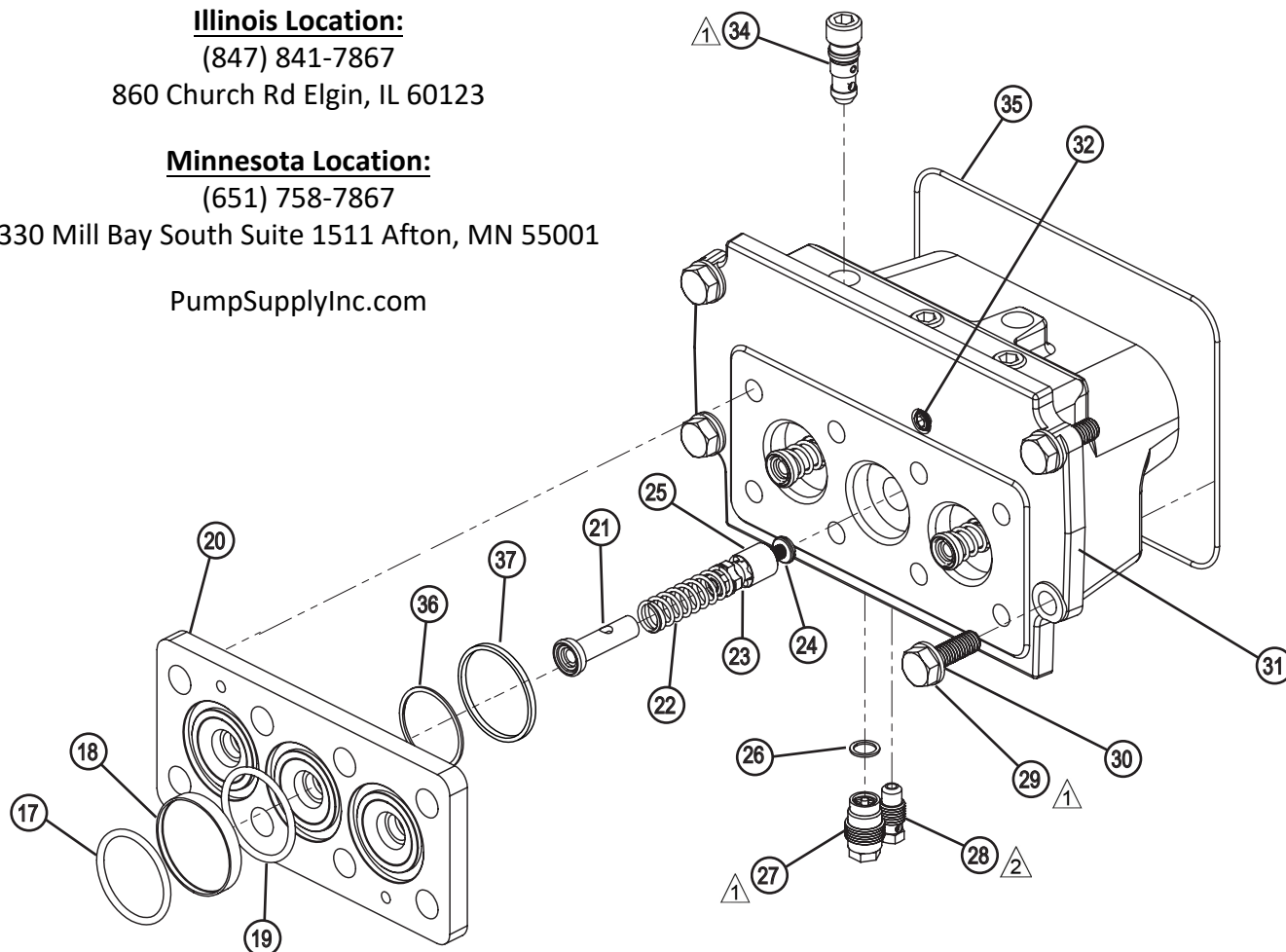



MT8 Drive End Parts List

- TORQUE TO 10 ± 2 FT/LBS
- TORQUE TO 20 ± 2 FT/LBS

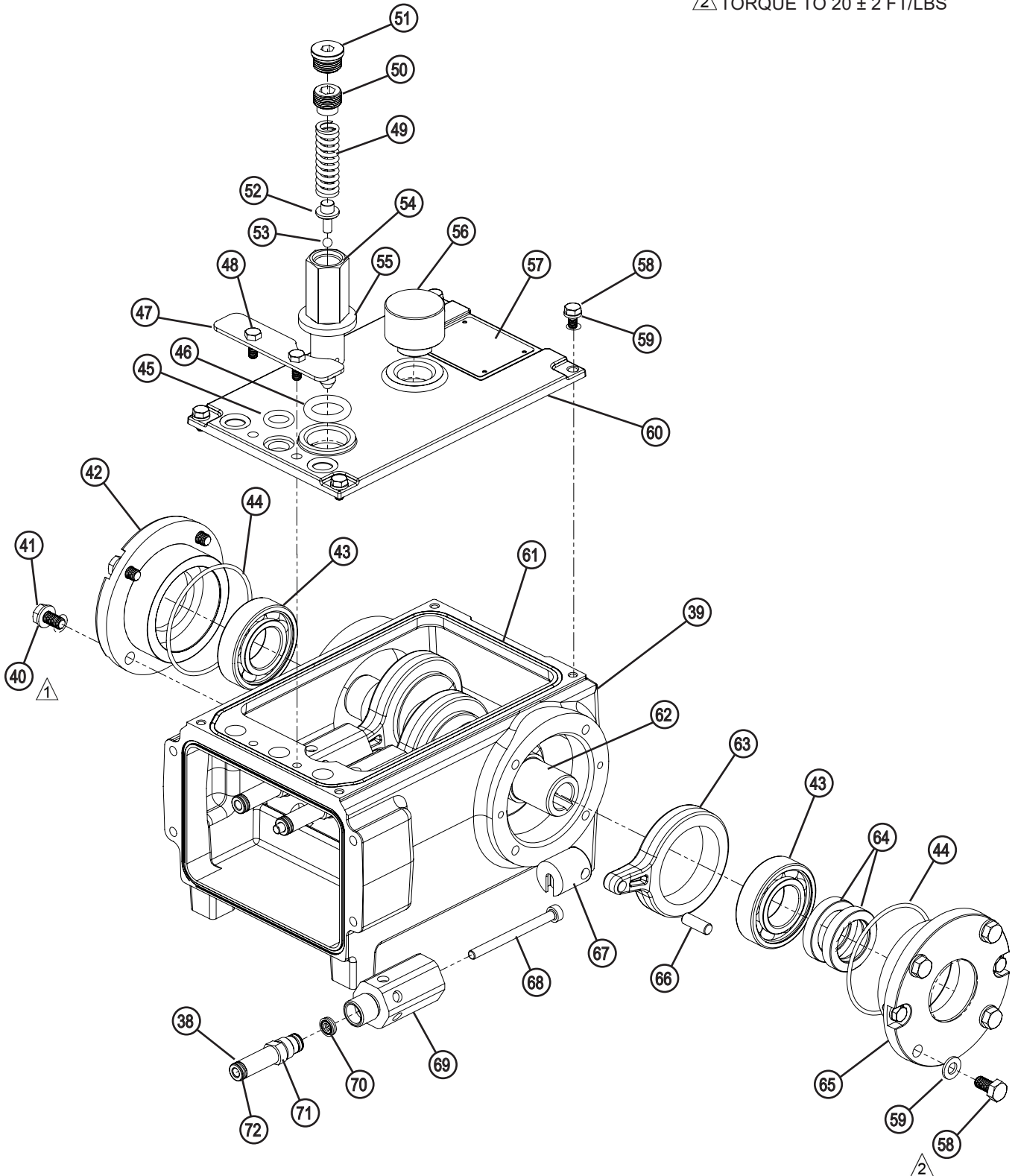

MT8 Drive End Parts List (Cont'd)



Ref. No.	Part Number	Description	Quantity/ Pump
38	190-223	Backup Ring, PTFE.....	6
39	190-001-02	Housing, Crankcase.....	1
40	190-093	Washer, M8	4
41	190-095	Bolt, HHCS, M8.....	4
42	190-090-03	Cover, Bearing, Closed End.....	1
43	D03-010-2910	Bearing, Front.....	2
44	190-043	O-ring, NBR	2
45	190-305	O-ring, FKM	3
46	190-083	O-ring, FKM	1
47	190-047	Plate, PRV Ports	1
48	190-014	Bolt, Hex Head, M6	2
49	190-061	Spring	1
50	190-304	Set-Screw, Half Dog.....	1
51	190-077	Plug, SAE 1/2 Tube	1
52	190-059	Valve Rod	1
53	D25-015-3010	Ball, 1/4" Diameter.....	1
54	190-058	Relief Valve Body	1
55	190-037	PRV Valve Shim	1
56	D03-039-1250	Assembly, Sealing Metal Oil Cap.....	1
57	190-013	Data Label	1
58	190-094	Bolt, HHCS, M6.....	6
59	190-092	Washer, M6	6
60	190-024-02	Cover, Crankcase.....	1
61	190-306	O-ring, FKM	1
62	190-002-05	Crankshaft.....	1
63	190-005-02	Connecting Rod	3
64	F20-031-2110	Seal, CR 11615.....	2
65	190-090-02	Cover, Bearing, Shaft End	1
66	190-029	Wrist Pin	3
67	190-008	Crosshead.....	3
68	190-006	Plunger	3
69	190-019	Cylinder Gland	3
70	190-020	Seal, Polypak	3
71	190-007	Cylinder	3
72	190-220	O-ring, NBR	6



Illinois Location:

(847) 841-7867

860 Church Rd Elgin, IL 60123

Minnesota Location:

(651) 758-7867

330 Mill Bay South Suite 1511 Afton, MN 55001

PumpSupplyInc.com

MT8 Gearbox and Baseplate Parts List

Ref. No.	Part Number	Description	Quantity/ Pump
73	190-900-N	Pump Assembly	1
	190-900-M	Pump Assembly	1
74	190-105	Weldment, Base Plate, MT8.....	1
	190-236	Weldment, Base Plate, MT8, SST	1
75	190-106	Weldment, Gearbox Support	1
	190-237	Weldment, Gearbox Support, SST	1
76	112-400	Gearbox / Ratio 100:1	1
	112-401	Gearbox / Ratio 80:1	1
	112-402	Gearbox / Ratio 60:1	1
	112-403	Gearbox / Ratio 50:1	1
	112-404	Gearbox / Ratio 40:1	1
	112-405	Gearbox / Ratio 30:1	1
	112-407	Gearbox / Ratio 20:1	1
	112-409	Gearbox / Ratio 10:1	1
	112-410	Gearbox / Ratio 7.5:1	1
	112-411	Gearbox / Ratio 5:1	1

Ref. No.	Part Number	Description	Quantity/ Pump
77	112-555	Input Flange Kit, NEMA 56C Adapter	1
	112-556	Input Flange Kit, 143/145 TC Adapter	1
	112-558	Input Flange Kit, IEC 63 Adapter	1
	112-559	Input Flange Kit, IEC 71 Adapter	1
	112-560	Input Flange Kit, IEC 80 Adapter	1
78	190-040	Shaft, MT8 Gearbox.....	1
79	190-092	Washer, M6	6
80	190-097	Screw, HHCS, M6	6
81	190-093	Washer, M8	8
82	190-095	Bolt, HHCS, M8.....	4
83	190-096	Bolt, Hex Head, M8	4
84	D25-085-2210	Key, 1/4 Sq x 1.40 LG.....	1
85	112-151	Key, 6 x 6 x 20 mm.....	1



⚠ TORQUE TO 10 ± 2 FT/LBS

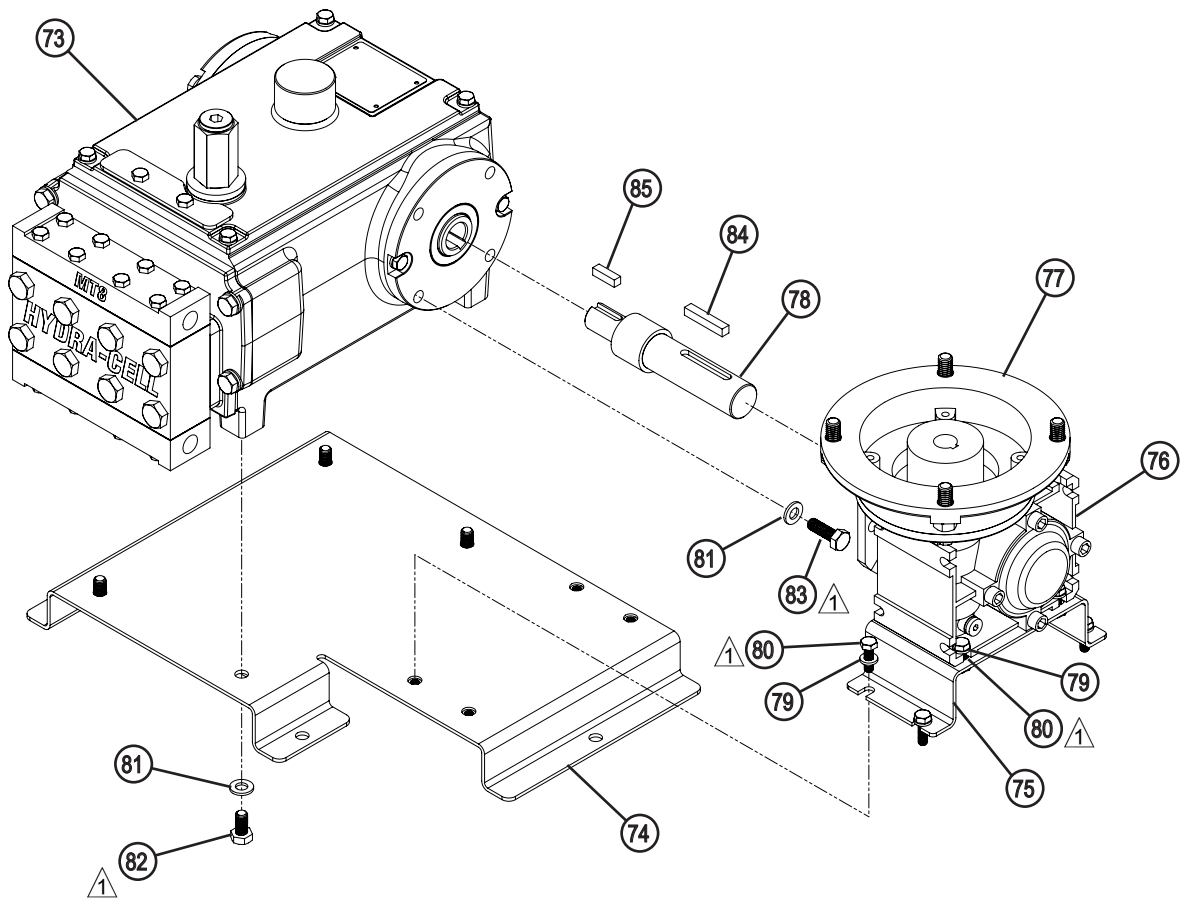

MT8 Duplex Option



Ref. No.	Part Number	Description	Quantity/ Pump
75	190-106	Weldment, Gearbox Support	1
	190-237	Weldment, Gearbox Support, SST	1
76	112-400	Gearbox / Ratio 100:1	1
	112-401	Gearbox / Ratio 80:1	1
	112-402	Gearbox / Ratio 60:1	1
	112-403	Gearbox / Ratio 50:1	1
	112-404	Gearbox / Ratio 40:1	1
	112-405	Gearbox / Ratio 30:1	1
	112-407	Gearbox / Ratio 20:1	1
	112-409	Gearbox / Ratio 10:1	1
	112-410	Gearbox / Ratio 7.5:1	1
	112-411	Gearbox / Ratio 5:1	1
77	112-555	Input Flange Kit, NEMA 56C Adapter	1
	112-556	Input Flange Kit, 143/145 TC Adapter	1
	112-558	Input Flange Kit, IEC 63 Adapter	1
	112-559	Input Flange Kit, IEC 71 Adapter	1
	112-560	Input Flange Kit, IEC 80 Adapter	1
	78	190-040	Shaft, MT8 Gearbox
79	190-092	Washer, M6	6
80	190-097	Screw, HHCS, M6	6
81	190-093	Washer, M8	16
82	190-095	Bolt, HHCS, M8	8

Ref. No.	Part Number	Description	Quantity/ Pump
83	190-096	Bolt, Hex Head, M8	8
84	D25-085-2210	Key, 1/4 SQ x 140 LG	1
85	112-151	Key, 6mm x 6mm x 17mm	2
96	190-240	Baseplate, MT8 Duplex, Painted Steel	1
	190-244	Baseplate, MT8 Duplex, SST	1
97	190-130	Shaft, MT8 Duplex	1
98	112-161	Retaining Ring, 1" External	1
99	112-162	Output Flange, FB40	1



Illinois Location:

(847) 841-7867
860 Church Rd Elgin, IL 60123

Minnesota Location:

(651) 758-7867
330 Mill Bay South Suite 1511 Afton, MN 55001

PumpSupplyInc.com

TORQUE TO 20 ± 2 FT/LBS

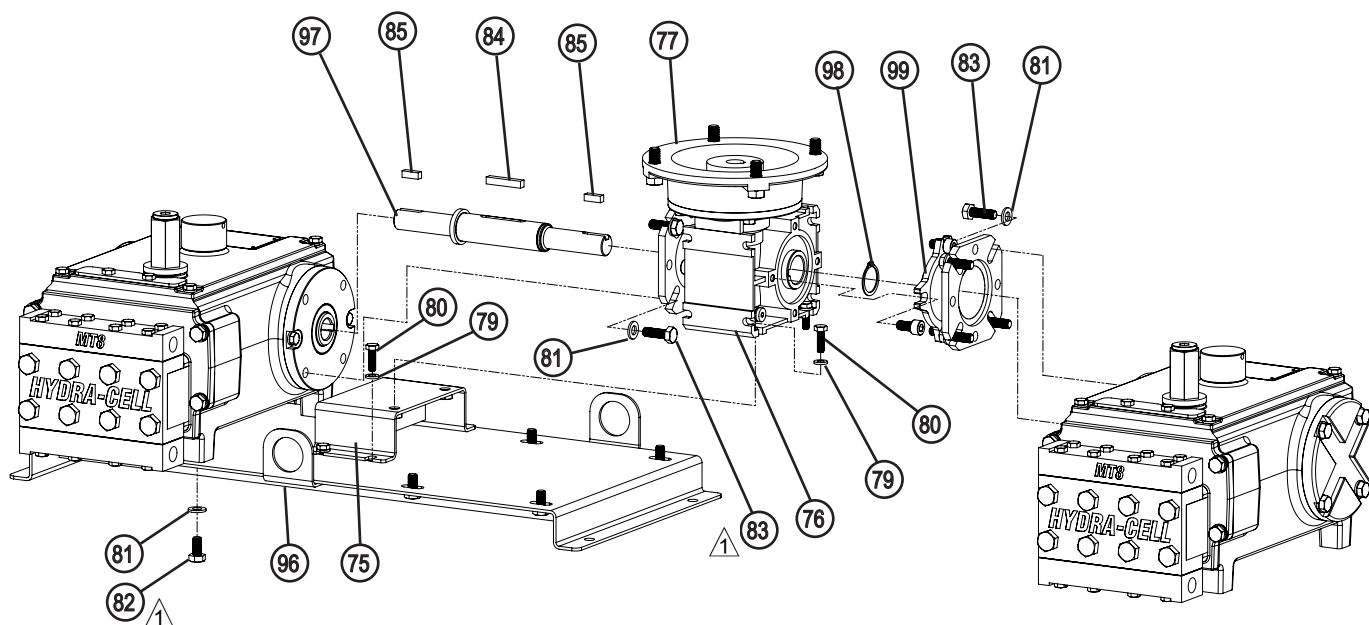

MT8 Manual Adjust Gearbox Parts List

Ref. No.	Part Number	Description	Quantity/ Pump
86	190-248	Base Plate, Painted, Mag.....	1
	190-251	Base Plate, SST, Mag.....	1
87	190-045	Adapter, Manual Adjust Gearbox.....	1
88	190-252	Bolt, Flat Head, M8.....	4
89	112-852	IEC 80 B14.....	1
	112-853	IEC 90 B14.....	1
	112-854	NEMA 56C.....	1
90	112-031	Washer, Flat 3/8 SST.....	8
91	101-749	Screw, HHCS, 3/8-16 SST.....	4
92	100-036	Locknut, 3/8-16 SST.....	4
93	100-915	Washer, Flat Special, 5/16.....	4
94	100-948	Screw, HHCS, 5/16-18.....	4
95	100-938	Locknut, 5/16-18.....	4



Illinois Location:

(847) 841-7867

860 Church Rd Elgin, IL 60123

Minnesota Location:

(651) 758-7867

330 Mill Bay South Suite 1511 Afton, MN 55001

PumpSupplyInc.com

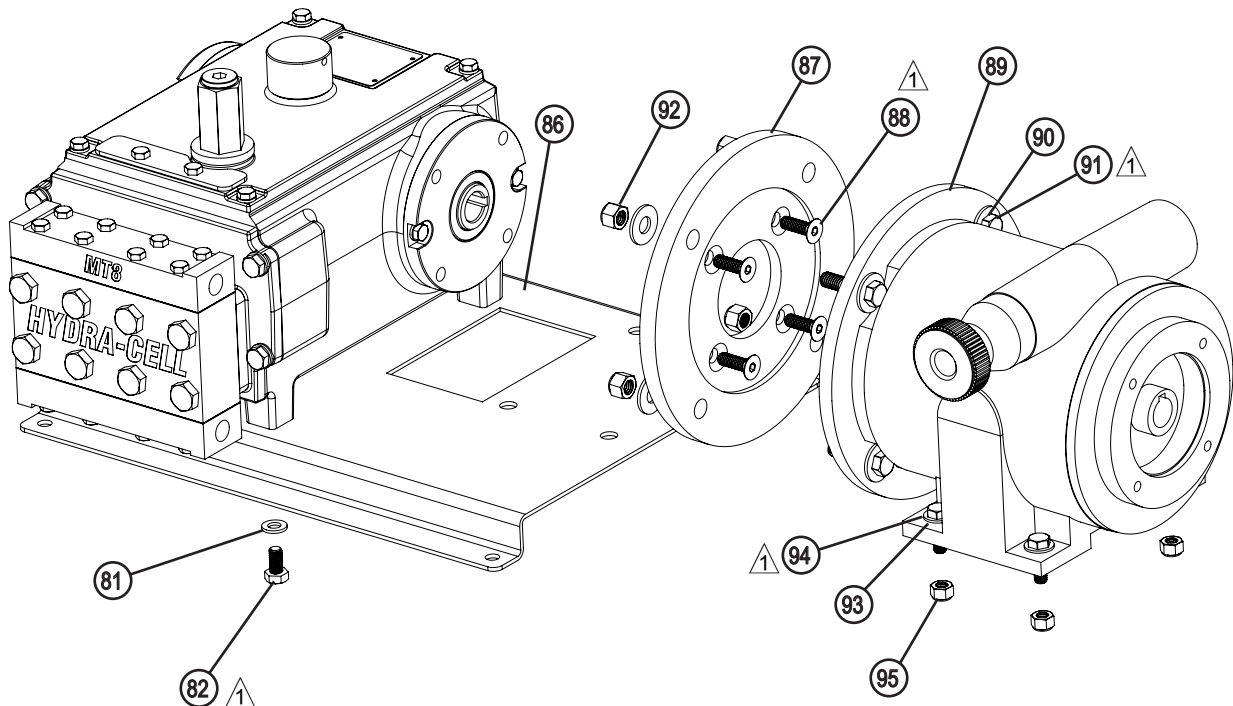

MT8 Troubleshooting



Problem	Probable Cause	Solution
Motor/Pump Does Not Operate	No power.	Supply correct power according to motor requirements.
	Blown fuse/tripped circuit breaker.	Replace/reset, eliminate circuit overload.
	Shaft coupling to pump not in place.	Install proper coupling hardware (see parts list).
	Current overload - motor.	Motor not rated for pump operating conditions - install proper motor.
	Thermal overload - motor.	Motor not rated for pump and/or ambient operating conditions - supply cooling system or install proper motor.
	Faulty motor drive/controller.	Repair/replace.
	Faulty motor.	Repair/replace.
	Low liquid level in supply tank (if low-level shut-off is used).	Fill tank.
No Delivery	Supply tank empty.	Fill tank.
	Loss of prime	Re-prime using Initial Start-Up Procedure.
	Inlet line or strainer clogged.	Clear debris and flush, or replace.
	Inadequate supply pressure at pump inlet.	Increase supply pressure by raising fluid level in tank, raising tank, or pressurizing suction tank.
	Inlet line too restrictive.	Increase inlet line diameter and/or decrease inlet line length.
	Fluid viscosity too high.	Reduce viscosity if possible (by heat or some other means). Increase inlet line diameter and/or decrease inlet line length. Increase supply pressure.
	Vapor lock/cavitation.	Increase inlet pressure. Decrease fluid temperature.
	Pump valves held open or worn out.	Clear debris and flush, or replace (see Fluid End Service)
	System relief valve actuating.	Adjust relief valve, or repair, clean, or replace with new relief valve.
Delivery Too Low and/or Erratic	Review all Probable Causes and Solutions in No Delivery section on previous page.	
	Air leak(s) in inlet line.	Locate all leaks and repair.
	System back pressure too low.	Adjust back pressure valve to higher setting. Install back pressure valve if none in system.
	Pumped fluid characteristics changed.	Monitor supply tank temperature to determine if fluid is too hot (leading to cavitation) or too cold (increasing fluid viscosity). Stabilize temperature at suitable level to resolve problem. Check for entrapped air in the fluid supply system.
	Inlet supply pressure changed.	Monitor inlet supply pressure (at the pump) to determine if it is too low, causing a starved condition/cavitation. Stabilize pressure at suitable level to resolve problem.
	Pump OK - Calibration system or flow meter error.	Evaluate components and repair/correct problem(s).
	Oil condition in pump hydraulic end changed.	Check oil level - if low evaluate for source of leakage. Consult factory for hydraulic end service.
Change oil per recommended guidelines in maintenance section.		
Delivery Too High and/or Erratic.	System back pressure too low.	Adjust back pressure valve to higher setting. Install back pressure valve if none in system.
	Inlet supply pressure changed.	Monitor inlet supply pressure (at the pump) to determine if it is too high, causing a "flow-through" condition. Stabilize pressure at suitable level to resolve problem.
	Pump OK - Calibration system or flow meter error.	Evaluate components and repair / correct problem(s).

MT8 Pump Series Replacement Parts Kits

TO ORDER REPLACEMENT PARTS KIT: A Replacement Parts Kit contains 11 digits corresponding to customer-specified design options.

1	2	3	4	5	6	7	8	9	10	11
---	---	---	---	---	---	---	---	---	----	----

Digit(s)	Order Code	Description
1-4	MT08	Pump Configuration For all MT8 Pumps
5	K D V	Kit Designator Complete Fluid End Kit Diaphragm Kit Valve Kit*
6-7	51	Pump Head Version Standard
8	J	Diaphragm & O-ring Material PTFE - No Leak Detection
9-10	SS TT AA XX	Check Valve Material 316 SST Hastelloy C Alloy 20 Not included in Diaphragm Kit
11	G K X	Hydraulic End Oil** 5W30 (Synthetic oil) Food contact oil Not included in Valve Kit

* Manifold body does not need to be removed to access check valve cartridges. If manifold body is removed, the diaphragms must be replaced.

** K & D kits include hydraulic end oil; oil not included in V kits.

MT8 Replacement Parts Kit Contents

Part Number*	Description	QTY	Kit Designator		
			K	D	V
190-905__	Check Valve Assembly	6	•		•
190-301	O-Ring (PTFE)	6	•		•
D40-047-2114	O-Ring (PTFE Ecapsulated)	6	•		•
190-261	Crush Ring	6	•		•
190-050-10	O-Ring (NBR)	3	•	•	
190-050-11	O-Ring (PTFE Ecapsulated)	3	•		•
190-018-07	Diaphragm	3	•		•

*Last two digits of part number with -__ refer to specific material of construction.

Optional plug kits available per page 8 for unused ports upon installation

MT8 Plug Kit Contents

Kit Number	Components	Description	QTY
190-910-01	190-120-01	Plug, 316 SST NPT	2
190-910-04	190-120-04	Plug, 316 SST BSPT	2
190-910-03	190-120-03	Plug, Alloy 20 NPT	2
190-910-06	190-120-06	Plug, Alloy 20 BSPT	2
190-910-02	190-120-02	Plug, Hastelloy NPT	2
190-910-05	190-120-05	Plug, Hastelloy BSPT	2

Each kit contains appropriate plugs above, 1 tube of thread sealant and 1 instruction card.



Illinois Location:

(847) 841-7867

860 Church Rd Elgin, IL 60123

Minnesota Location:

(651) 758-7867

330 Mill Bay South Suite 1511 Afton, MN 55001

PumpSupplyInc.com



MT8 - Warranty

Limited Warranty

Wanner Engineering, Inc. ("Wanner") extends to the original purchaser of equipment supplied or manufactured by Wanner and bearing its name, a limited one-year warranty from the date of purchase against defects in material or workmanship, under normal use and service, and provided the equipment is installed, operated and maintained in accordance with instructions supplied by Wanner. Wanner will repair or replace, at its option, defective parts without charge if: (a) you provide written notice of any defect within thirty (30) days from the discovery of the defect; (b) the claim is received by Wanner before the expiration of the warranty period; and (c) such parts are returned with transportation charges prepaid to Wanner Engineering, Inc., 1204 Chestnut Avenue, Minneapolis, Minnesota 55403. A return goods authorization must be received prior to the return of the defective part. No allowance will be made for repairs undertaken without Wanner written consent or approval.

Notwithstanding anything to the contrary, this warranty does not cover:

1. Electric motors (if applicable) not manufactured by Wanner. The warranties, if any, on such equipment are assigned to you by Wanner (without recourse) at the time of purchase.
2. Normal wear and/or damage caused by or related to abrasion, corrosion, abuse, negligence, accident, faulty installation or tampering which impairs normal operation.
3. Transportation costs.

This limited warranty is exclusive, and is in lieu of any other warranties (oral, express, implied or statutory) including, but not limited to, implied warranties of merchantability and fitness for a particular purpose; warranties of non-infringement; warranties arising from course of dealing or usage of trade or any other matter. Any descriptions of the equipment, drawings, specifications, and any samples, models, bulletins, or similar material used in connection with the sale of equipment are for the sole purpose of identifying the equipment and are not to be construed as an express warranty that the equipment will conform to such description. Any field advisory or installation support is advisory only. Every form of liability for direct, special, incidental or consequential damages or loss is expressly excluded and denied. All liability of Wanner shall terminate one (1) year from the date of purchase of the equipment.

Illinois Location:

(847) 841-7867

860 Church Rd Elgin, IL 60120

Minnesota Location:

(651) 758-7867

330 Mill Bay South Suite
Afton, MN 55001

PumpSupplyInc.com

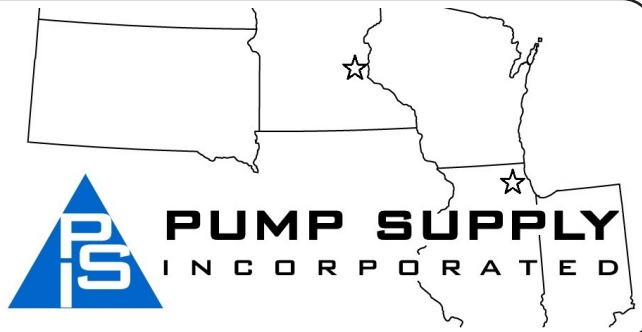



Wanner worldwide

GLOBAL SALES & TECHNICAL SUPPORT

WANNER ENGINEERING, INC.™

WORLD HEADQUARTERS &
MANUFACTURING

Minneapolis, Minnesota USA

t: 612-332-5681

e: sales@wannereng.com

Hydra-Cell.com

REGIONAL OFFICE

Wichita Falls, Texas USA

t: 940-322-7111

e: sales@wannereng.com

LATIN AMERICAN OFFICE

São Paulo, Brazil

t: +55 (11) 99582-1969

e: mmagoni@wannereng.com

Hydra-Cell-Pumps.com.br

WANNER INTERNATIONAL, LTD.™

UNITED KINGDOM

8 & 9 Fleet Business Park

Sandy Lane • Church Crookham

Hampshire UK GU52 8BF

t: +44 (0) 1252 816847

e: support@wannerint.com

Hydra-Cell.co.uk

WANNER PUMPS, LTD.™

Kowloon, HONG KONG

t: +852 3428 6534

e: sales@wannerpumps.com

WannerPumps.com

Shanghai, CHINA

t: +86-21-6876 3700

e: sales@wannerpumps.com

WannerPumps.com

Illinois Location:
(847) 841-7867
860 Church Rd Elgin, IL 60120

Minnesota Location:
(651) 758-7867
330 Mill Bay South Suite
Afton, MN 55001

PumpSupplyInc.com

The graphic shows a map of the United States with two stars: one in Illinois and one in Minnesota. Below the map is the Pump Supply Incorporated logo, which consists of a blue triangle with 'PS' inside, followed by the text 'PUMP SUPPLY INCORPORATED' in a bold, sans-serif font.

