

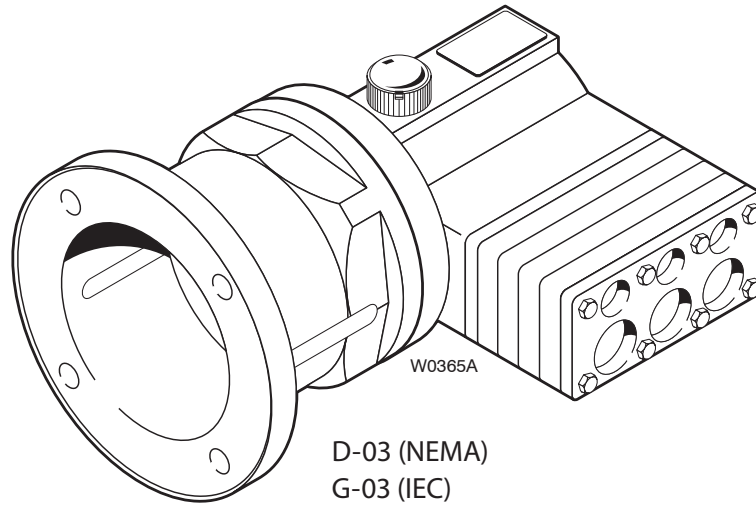

Pump/Motor Adapters

Adapter Kits for D/G-03



Part Number Description

A04-001-1202	D-03 Pump/Motor Adapter Kit for NEMA 56C, 143/145TC C-Face Motors
A04-002-1202	D-03 Pump/Motor Adapter Kit for NEMA 182/184TC, 213/215TC C-Face Motors
A04-003-1202	G-03 Pump/Motor Adapter Kit for IEC 80-90 B5 Flange Motors
A04-004-1202	G-03 Pump/Motor Adapter Kit for IEC 100-112 B5 Flange Motors

Dimensions

inches (mm)

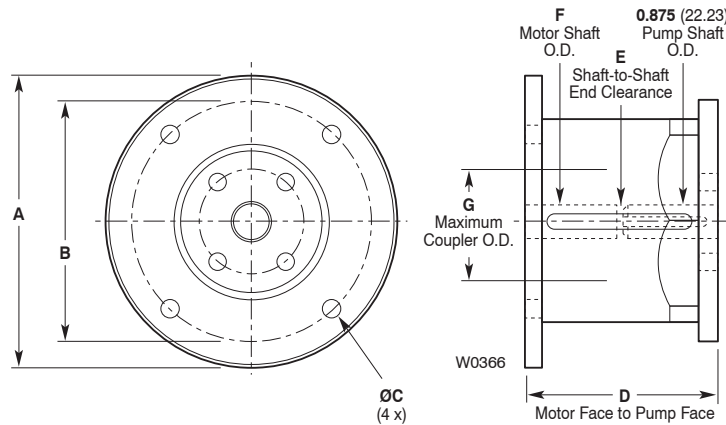

Adapter Kit Part Number	Adapter Kit Motor Size	Dimensions in (mm)							
		A	B	C	D	E	F	G	
A04-001-1202	NEMA 56C	7.00	5.875	0.422	4.45	0.15	0.625	4.33	
	NEMA 143/145TC	7.00	5.875	0.422	4.45	0.09	0.875	4.33	
A04-002-1202	NEMA 182/184TC	8.75	7.25	0.54	5.5	0.85	1.125	4.75	
	NEMA 213/215TC	8.75	7.25	0.54	5.5	0.10	1.375	4.75	
A04-003-1202	IEC 80 B5	(184)	(165)	(11.1)	(110)	(13.2)	(19)	(110)	
	IEC 90 B5	(184)	(165)	(11.1)	(110)	(3.3)	(24)	(110)	
A04-004-1202	IEC 100-112 B5	(244)	(215)	(12.7)	(125)	(12.4)	(28)	(121)	



WANNER ENGINEERING, INC.





Pump/Motor Adapters

Installation for D/G-03

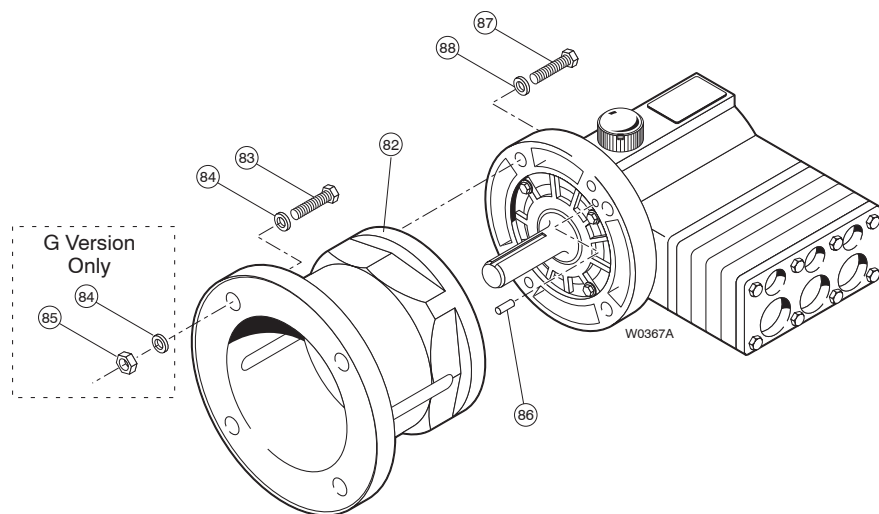

Installation:

Install motor shaft key and slide coupling (not included in Adapter Kit), over motor shaft.

Assemble adapter (82) to motor using cap screws (83) and lockwashers (84). IEC motors use additional lockwashers (84) and nuts (85).

Press/tap alignment pins (86) into adapter at 5 and 11 o'clock positions.

With coupling sleeve positioned on motor shaft hub and second coupling hub engaged to pump shaft and key, assemble pump onto motor adapter making sure to engage alignment pins into adapter flange holes.

Fasten pump to adapter using socket-head cap screws (87) with lockwashers (88).

Make any adjustments to the position of the coupling hubs through the access slots in the sides of the adapter. Tighten coupling set screws.

Adapter Kit Contents:

Ref No.	Description	D Versions (NEMA)		Quantity/Kit	G Versions (IEC)		Quantity/Kit
		A04-001-1202 56C-145TC Part Number	A04-002-1202 182-215TC Part Number		A04-003-1202 80-90 Part Number	A04-004-1202 100-112 Part Number	
82	Pump/Motor Adapter	A04-032-1000	A04-033-1002	1	A04-032-1001	A04-033-1003	1
83	Cap Screw,	D10-087-2010	M10-110-2000	4	G03-068-2010	A04-043-2010	4
		Hex-head, 3/8"	Hex-head, 1/2"		Socket-head, M10	Socket-head, M12	
84	Lockwasher	D10-048-2010	M10-111-2000	4	A04-044-2010	M10-111-2000	8
		3/8"	1/2"		M10	M12	
85	Nut	—	—		A04-047-2010	A04-045-2010	4
					M10	M12	
86	Pin	D03-026-2211	D03-026-2211	2	D03-026-2211	D03-026-2211	2
87	Cap Screw, socket-head, M10	G03-068-2010	G03-068-2010	4	G03-068-2010	G03-068-2010	4
88	Lockwasher, M10	G25-048-2010	G25-048-2010	4	G25-048-2010	G25-048-2010	4



Illinois Location:
(847) 841-7867
860 Church Rd Elgin, IL 60120

Minnesota Location:
(651) 758-7867
330 Mill Bay South Suite
Afton, MN 55001

PumpSupplyInc.com

