



## 316 SS MODELS: M154T, 154S/T, 204T, 204 S/T, 304 T

### OPERATING INSTRUCTIONS, INSTALLATION & MAINTENANCE MANUAL INCLUDING SPARE PARTS LIST



**Illinois Location:**

(847) 841-7867  
860 Church Rd Elgin, IL 60120

**Minnesota Location:**

(651) 758-7867  
330 Mill Bay South Suite  
Afton, MN 55001

PumpSupplyInc.com



ISO 9001 Certified



## LIFE IS PRECIOUS - THINK SAFETY

1. Most accidents can be avoided by using COMMON SENSE.
2. Please read the operation and maintenance instruction manual supplied with the pump. If you did not receive one, please call your local distributor before pump installation.
3. Do not wear loose apparel that may become entangled in the impeller or other moving parts.
4. Always use appropriate safety equipment, such as safety glasses, when working on the pump or piping.
5. Pumps build up heat and pressure during operation-allow time for pumps to cool before handling or servicing.
6. Only qualified service personnel should install, operate and repair pump.
7. Keep clear of suction and discharge openings. DO NOT insert fingers in pump with power connected.
8. Do not pump flammable or hazardous materials (gasoline, acids, alkalis, etc.)
9. Do not block or restrict discharge hose, as it may whip or burst catastrophically under pressure.
10. Make sure lifting handles/hooks are securely fastened each time before lifting.
11. Do not lift pump by the power cord under any circumstances.
12. Do not exceed manufacturer's recommendation for optimum performance, as this could cause the motor/pump to overheat and lead to premature wear or failure.
13. Secure the pump in its operating position so it does not tip over, fall or slide.
14. Keep away from impeller when power is connected.
15. Submersible Pumps are not approved for use in swimming pools, recreational water installations, decorative fountains or any installation where human contact with the pumped fluid is common.
16. Do not operate pump without adequate protection and safety devices in place.
17. Always replace safety devices that have been removed during service or repair.
18. To reduce risk of electrical shock, pump must be properly grounded in accordance with the National Electric Code and all applicable state and local codes and ordinances.
19. To reduce risk of electrical shock, always disconnect the pump from the power source before handling or servicing.
20. Any wiring of pumps should be performed by a qualified electrician.
21. Never operate a pump with a power cord that has frayed or brittle insulation.
22. Cable should be protected at all times to avoid punctures, cuts, and abrasions - inspect frequently.
23. Never handle connected - "hot" power cords with wet hands.
24. Never operate a pump with a plug-in type power cord without a ground fault circuit interrupter, adequate overload and short circuit protection.

**IMPORTANT !!!** MODY Pumps Inc. is not responsible for losses, injury, or death resulting from a failure to observe these safety precautions, misuse or abuse of pumps or equipment.

## GENERAL INFORMATION.

THE **"mody"** PORTABLE SUBMERSIBLE PUMPS CONSIST OF A SQUIRREL CAGE INDUCTION MOTOR DRIVING A CENTRIFUGAL PUMP. THE PUMP IMPELLER IS DIRECTLY MOUNTED ON THE MOTOR SHAFT EXTENSION, WITH A "SEAL MODULE" INCORPORATED BETWEEN THE PUMPING ELEMENT AND THE ELECTRIC MOTOR. THE PUMP CASING ENCOMPASSES THE MOTOR CASING, AND THE HEAT GENERATED IN THE MOTOR IS DISSIPATED BY THE WATER FLOWING PAST THE MOTOR CASING. THE DISCHARGE OUTLET OF THE PUMP IS 2" OR 3" SS NPT, DEPENDING ON THE HP. THE PUMPS CAN ALSO BE SUPPLIED WITH A SUITABLE ADAPTER FOR DIRECT CONNECTION TO A 2.5" OR 3" FIRE HOSE INSTANTANEOUS COUPLING.

THE MOTORS ARE RATED 5HP/3HP/2HP (MODEL M304T/M204T/M154T) SUITABLE FOR 230/460 VOLTS, 3 PHASE, 60 HZ POWER SUPPLY.(MOTORS ARE AVAILABLE FOR VARIOUS POWER SUPPLY CONFIGURATIONS -- PLEASE CHECK NAME PLATE ON THE PUMP VERY CAREFULLY TO CONFIRM THAT YOUR POWER SUPPLY MATCHES THE NAME PLATE DETAILS). ALL MOTORS ARE RATED CLASS "F" INSULATION. THE MOTOR CASING AND PUMP CASING ARE CAST/FABRICATED 316SS SECTIONS FOR MAXIMUM STRENGTH AND CORROSION RESISTANCE. THE IMPELLERS ARE TYPICALLY 410 HARDENED TO ENSURE MAXIMUM ABRASION RESISTANCE AND LONG LIFE. (IMPELLERS ARE ALSO AVAILABLE IN 316 STAINLESS STEEL WHICH ARE NORMALLY REQUIRED FOR CORROSION RESISTANT APPLICATIONS). IMPELLERS ARE OF MIXED FLOW DESIGN WITH A HIGH HYDRAULIC EFFICIENCY. THE 316 SS STRAINER IS RUGGED ENOUGH TO WITHSTAND ABRASIVE AND CORROSIVE APPLICATIONS.

ALL **"mody"** SUBMERSIBLE SUMP PUMPS INCORPORATE A UNIQUE SEALING SYSTEM. THE MODULAR CONSTRUCTION CONSISTS OF TWO MECHANICAL SEALS, ARRANGED IN TANDEM. THE COMPLETE PACKAGE IS WHOLLY ENCLOSED IN A PRESSURE COMPENSATED OIL BAG WHICH ACTS AS A SEALING DEVICE THAT ENSURES A MINIMAL PRESSURE DIFFERENTIAL ACROSS THE SEAL FACES IRRESPECTIVE OF THE DEPTH SETTING OF THE PUMP, OR THE HEAD AGAINST WHICH THE PUMP IS OPERATING.

ALL WEAR PARTS OF THE PUMPING UNIT ARE LINED WITH NITRILE RUBBER, MAKING THEM EXTREMELY RESILIENT AND ABRASION RESISTANT. THE SS MOTOR SHAFT IS EXTRA WIDE FOR ADDED STIFFNESS AND CAN WITHSTAND SEVERE RADIAL AND THRUST LOADS.

IT IS IN THE INTEREST OF THE USER THAT HE/SHE GO THROUGH THIS MANUAL IN DETAIL PRIOR TO USING THE PUMP. THIS MANUAL WILL HELP HIM/HER UNDERSTAND THE CONSTRUCTIONAL FEATURES AND TO OBTAIN TROUBLE FREE SERVICE FROM THE PUMP.

## OVERALL DIMENSIONS AND WEIGHT (M304T)

<b>OVERALL HEIGHT</b>	<b>28.5"</b>
<b>MAXIMUM DIAMETER</b>	<b>7.5"</b>
<b>MAXIMUM WEIGHT(EXCL. CABLE)</b>	<b>125 lbs.</b>

**Illinois Location:**  
(847) 841-7867  
860 Church Rd Elgin, IL 60120

**Minnesota Location:**  
(651) 758-7867  
330 Mill Bay South Suite  
Afton, MN 55001

PumpSupplyInc.com





**PUMP SUPPLY**  
INCORPORATED

## INSTALLATION.

- CHECK THAT THE SITE VOLTAGE CORRESPONDS WITH THAT OF THE PUMP.
- CHECK THAT FUSES ARE INTACT.
- USE SHORTEST POSSIBLE HOSE IN RECOMMENDED DIMENSION. AVOID SHARP BENDS, CREASES, AND CONTRACTIONS.
- NEVER LIFT OR PULL THE PUMP BY MEANS OF THE CABLE. SUSPEND THE PUMP BY A ROPE OR PREFERABLY PLACE IT ON A SOLID BASE.
- **THE MAXIMUM PUMP SUBMERGENCE RECOMMENDED IS 50 Feet.**
- **THE SPECIFIC GRAVITY OF THE PUMPED FLUID SHOULD NOT EXCEED 1.1 UNDER ANY CIRCUMSTANCES.**
- WINDING WITH RESPECT TO EARTH: MINIMUM INSULATION RESISTANCE SHOULD BE 5 MEGOHMS. WIRE THE PUMP TO THE MAINS CORRECTLY. ALWAYS USE A STARTER OR A PANEL BOARD. SEE INSTRUCTIONS UNDER "MOTOR PROTECTION" BELOW.
- AT THE STARTING MOMENT, THE PUMP SHALL MAKE A KICK, WHICH IS OPPOSITE TO THE DIRECTION OF ROTATION OF THE IMPELLER. SHIFT TWO PHASES IN THE POWER CONNECTION IF THE KICK IS IN THE WRONG DIRECTION. THE CORRECT DIRECTION IS INDICATED ON THE PUMP COVER AT THE TOP OF THE PUMP. (THIS IS NOT NECESSARY WITH SINGLE PHASE PUMPS, AS THEIR DIRECTION OF ROTATION IS FIXED AND CANNOT BE CHANGED. HOWEVER, ENSURE THAT THE CONNECTIONS WITH THE PANEL BOARD SUPPLIED WITH THE UNIT, ARE DONE AS PER COLOR CODE INDICATED IN THE PANEL/MOTOR LEADS). SINGLE PHASE MOTOR LEADS: RED-STARTING, BLUE/BLACK-RUNNING, YELLOW/WHITE-COMMON, GREEN-GROUND.
- THE DIRECTION OF ROTATION CAN BE ESTABLISHED BEFORE IMMERSING THE PUMP IN WATER. DO NOT HOWEVER, RUN THE PUMP FOR MORE THAN 60 SECONDS OUTSIDE THE WATER. IMMERSE THE PUMP AND ENERGISE THE UNIT. CHECK THE AMPERES DRAWN BY THE UNIT. THE AMPERAGE SHOULD BE LESS THAN OR EQUAL TO THE FULL LOAD AMPS AS INDICATED ON THE NAMEPLATE.

## H.R.C. FUSES ARE RECOMMENDED STRONGLY AS PER TABLE BELOW.

MAINS VOLTAGE AT SITE	HRC FUSE RECOMMENDED		
	M304T	M204T	M154T
230 VOLTS 3 PHASE	25 AMPS	16 AMPS	10 AMPS
460 VOLTS 3 PHASE	16 AMPS	10 AMPS	10 AMPS
230 VOLTS 1 PHASE	30 AMPS	20 AMPS	20 AMPS

## MOTOR PROTECTION

ADEQUATE MOTOR PROTECTION MUST BE PROVIDED FOR THE PUMPSET. OVERLOAD, SHORT CIRCUIT & SINGLE PHASE PROTECTION ARE VITAL FOR ANY INSTALLATION. WE STRONGLY RECOMMEND USING CONTROL PANELS INCORPORATING ALL THE NECESSARY PROTECTION. PLEASE CONTACT YOUR NEAREST DISTRIBUTOR OR AUTHORIZED MODOY SERVICE CENTER FOR PRICING AND DETAILS. WARRANTY IS VOID IF PUMPS ARE OPERATED WITHOUT ADEQUATE MOTOR PROTECTION

### Illinois Location:

(847) 841-7867  
860 Church Rd Elgin, IL 61

### Minnesota Location:

(651) 758-7867  
330 Mill Bay South Suite :  
Afton, MN 55001

PumpSupplyInc.com



TROUBLE GUIDE	CAUSE	REMEDY
	1.FUSES BLOWN.	1.REPLACE FUSES
	2.CABLE DAMAGED	2.SHORTEN/REPLACE CABLE
PUMP DOES NOT START.	3 NO POWER.	3.-
	4.BLOCKED IMPELLER.	4.CLEAN BOTTOM PARTS.
	5.STATOR WINDING BURNT.	5.REPLACE STATOR.
	1.BLOCKED IMPELLER.	1.CLEAN BOTTOM PARTS.
	2.IMPELLER ROT. WRONG	2.SHIFT TWO PHASE CONN.
PUMP STARTS BUT STOPS.	3.CONNECTED FOR WRONG VOLTAGE.	3.CHECK & RECONNECT.
	4.VOLTAGE TOO LOW/HIGH.	4.APPROACH POWER CO.
	1.IMPELLER ROT.BACKWARD.	1.SHIFT TWO PHASE CONN.
	2.PUMP WORN DOWN.	2.REPLACE IMPELLER.
PUMP GIVES TOO LITTLE WATER.	3.LONG HOSE AND DIAMETER TOO SMALL.	3.CHECK PRESSURE LOSSES
	4.PRESSURE HEAD TOO HIGH	4.INSTALL BIGGER PUMP.

### MAINTENANCE REQUIREMENTS.

THE SERVICE LIFE OF A SUBMERSIBLE PUMP DEPENDS MAINLY ON TWO THINGS: THE DEPENDABILITY OF THE SEALING SYSTEM AND THE WEAR RESISTANCE OF THE PUMP ITSELF.

- CHECK LEVEL AND CONDITION OF THE OIL AT SERVICE EVERY SIX MONTHS. IF THE OIL IS EMULSIFIED BY WATER THE SEAL PACKAGE MUST BE REMOVED FROM THE ROTOR SHAFT FOR FURTHER ACTION.
- THE SHAFT SEAL SHOULD BE CHECKED FOR WEAR EVERY 2500 HRS. OF OPERATION. IF SEAL FACES SHOW ANY SIGNS OF WEAR, THEY SHOULD BE RECONDITIONED/REPLACED. REFER SHEET 2 FOR SERVICE OF THE SEAL PACKAGE.
- ENSURE THAT THE PUMP IS PROPERLY TRIMMED AT ALL TIMES. AS THE IMPELLER GETS WORN OUT, THE CAPACITY OF THE UNIT WILL DROP, AND IT IS ESSENTIAL TO MAINTAIN THE ORIGINAL CLEARANCE BETWEEN THE IMPELLER AND DIFFUSER TO OBTAIN SATISFACTORY PERFORMANCE. THIS CAN BE ADJUSTED BY INSERTING METALLIC SHIMS BEHIND THE IMPELLER BOSS.
- PERIODICALLY (ONCE A MONTH) IT IS ADVISABLE TO DISMANTLE THE STRAINER AND TO CLEAN THE IMPELLER CAVITIES. FREQUENTLY FOREIGN MATTER WILL BE DEPOSITED WHICH SHOULD BE CLEANED FOR OPTIMUM PERFORMANCE.

#### Illinois Location:

(847) 841-7867

860 Church Rd Elgin, IL 60

#### Minnesota Location:

(651) 758-7867

330 Mill Bay South Suite  
Afton, MN 55001

PumpSupplyInc.com

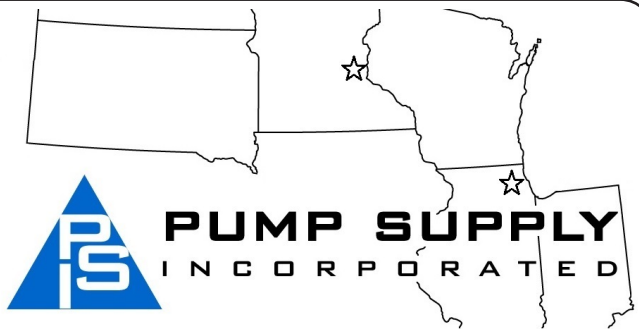

## **GENERAL OVERHAUL AND OIL CHECK. (ID NOS. ARE FOR MODEL M 304T/316SS)**

### **REFER DRAWINGS DWG/208/00 (SHEET 1 & 2) AT END OF MANUAL.**

- ALWAYS REPLACE O-RINGS WITH NEW ONES WHENEVER DISMANTLING AND RE- ASSEMBLING A PUMP. NEVER RE-USE OLD O-RINGS.
- UNSCREW BOLTS (69) - 4 NOS. AND REMOVE STRAINER (67)
- LOOSE NUTS (7) - 4 NOS. AND REMOVE DIFFUSER (66).
- THE IMPELLER IS NOW IN VIEW.
- PULL OUT OUTER CASING (33).
- LOOSEN IMPELLER LOCK NUT (65). REMOVE LOCK WASHER (64) AND SLIDE IMPELLER OFF THE KEY (62) ON THE SHAFT. REMOVE TRIMMING SPACERS (61) AND KEEP ASIDE. UNSCREW THE FOUR PH. HEAD SCREWS (54) AND REMOVE THE SAND GUARD (53) FROM THE SEAL HOUSING.
- THE SEAL CHAMBER CONTAINS APPROX. 1 LITER OF OIL. THE LEVEL AND CONDITION OF THE OIL SHOULD BE CHECKED EVERY SIX MONTHS. UNSCREW THE OIL PLUGS (45) AND POUR OUT SOME OIL. NOTE THAT THE OIL GETS A SLIGHTLY DARKER SHADE, BUT THIS IS NORMAL AND IS NO CAUSE FOR WORRY. IF THE OIL IS EMULSIFIED BY WATER, THE SEALS HAVE WORN OUT AND MUST BE REMOVED FROM THE ROTOR SHAFT FOR FURTHER ACTION.
- LOOSEN STUD ASSY. (60). TURN LARGE NUT PINNED ON STUD -- COUNTER CLOCKWISE AND UNSCREW THE SAME FROM STATOR CASING (34).
- TAP OFF WEAR PLATE (59).
- THE OIL DIAPHRAGM IS NOW IN VIEW. UNSCREW BOTH THE OIL PLUGS AND DRAIN OUT THE OIL FROM THE OIL CHAMBER. LOOSEN SCREWS AND NUTS (4&55) FROM THE BIG OIL CLAMP (56) AND REMOVE THE CLAMP. TURN OIL DIAPHRAGM INSIDE OUT AND REMOVE SMALL OIL BAG CLAMP (57) IN THE SAME FASHION. REMOVE OIL DIAPHRAGM. SLIDE OUT CAP FOR CIRCLIP (52) AND CIRCLIP (48) FROM ROTOR SHAFT. REMOVE LOWER MECHANICAL SEAL (47). BE VERY CAREFUL IN HANDLING THE SILICON CARBIDE SEAL FACE. LEAVE STATIONARY SILICON CARBIDE SEAT IN THE SEAL HOUSING (49). UNSCREW FOUR NUTS (50) AND PULL OUT SEAL HOUSING. THE STATIONARY SC FACE WILL COME OUT WITH THE SEAL HOUSING. THE UPPER MECHANICAL SEAL IS NOW IN VIEW. REMOVE THE UPPER SEAL IN THE SAME WAY AS THE LOWER SEAL. PLEASE HANDLE THE ROTATING SILICON CARBIDE SEAL FACE CAREFULLY. BY MEANS OF TWO SCREW DRIVERS PRY OUT THE LOWER BEARING BRACKET (44) FROM THE STATOR CASING (34). THE COMPLETE ROTOR ASSEMBLY WITH BEARING, BEARING COVER AND STATIONARY SC SEAT WILL COME OUT AS ONE ASSEMBLY. LOOSEN BOLTS (39) AND REMOVE BEARING COVER (41). PUSH OUT ROTOR WITH BEARING FROM LOWER BEARING BRACKET. (IF THIS IS DIFFICULT, USE A HAND PRESS TO REMOVE ROTOR FROM BEARING BRACKET). ENSURE THAT THERE IS NO DAMAGE TO THE SILICON CARBIDE STATIONARY SEAT IN THE BEARING BRACKET. THE SC SEAT CAN NOW BE PUSHED OUT BY HAND FROM THE BEARING SIDE. (DO NOT HAMMER THE SEAT).
- CHECK BOTH UPPER AND LOWER BEARINGS (37 & 42) FOR ANY RADIAL OR AXIAL PLAY OR ANY ABNORMAL NOISE WHILE SPINNING THE SAME. CHECK FOR ANY LEAKAGE OF GREASE THROUGH THE SHIELD OF THE BEARING. IF BEARING SEEMS WORN OUT OR ANY GREASE LEAKAGE IS OBSERVED, REPLACE BEARING. (DO NOT USE ANY STANDARD BEARING PROCURED FROM THE MARKET. THE PUMPS USE A SPECIAL BEARING WHICH IS PRE-FILLED WITH A SPECIAL HIGH TEMPERATURE GREASE WHICH ARE AVAILABLE FROM US READILY).

**Illinois Location:**

(847) 841-7867

860 Church Rd Elgin, IL 60120

**Minnesota Location:**

(651) 758-7867

330 Mill Bay South Suite  
Afton, MN 55001

PumpSupplyInc.com

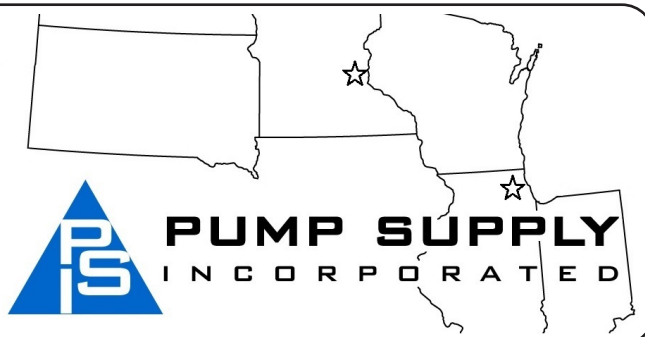

- LOOSEN SCREWS (4) AND REMOVE CABLE CLAMP (5). LOOSE NUTS (7) AND WITH THE HELP OF TWO SCREWDRIVERS, PRY OUT CABLE GLAND (8). THE GLAND BASE (13) WITH THE COMPLETE ASSEMBLY WILL BE EXPOSED. IF STATOR IS TO BE RE-WOUND/OVERHAULED SNIP OFF CABLE LEADS FROM WINDING LEADS. ALL RUBBER PARTS IN THE GLAND ASSEMBLY SHOULD BE REPLACED WHENEVER THE GLAND IS REMOVED FROM CAVITY.
- LOOSE BOLTS (20) - 4 NOS. AND PRY OFF TOP BRACKET FROM INNER CASING. IF TOOL KIT IS AVAILABLE USE STATOR PULLER (T8002) TO REMOVE TOP BRACKET FROM STATOR.
- THE STATOR IS SHRINK-FITTED IN THE INNER CASING. THE STATOR CAN NOW BE CHECKED FOR ANY ELECTRICAL FAULTS. MEG-OHM TEST THE WINDINGS AND PERFORM A LINE TO LINE RESISTANCE CHECK BETWEEN THE WINDINGS. IF THE STATOR IS WET BAKE IN AN OVEN FOR 4-5 HOURS AT 300F. HI-POT THE STATOR IF POSSIBLE AND CHECK INSULATION WITH RESPECT TO GROUND.
- THE REVERSE OF THE ABOVE PROCEDURE CAN BE FOLLOWED FOR RE-ASSEMBLY OF THE PUMP. PLEASE HOWEVER NOTE THE FOLLOWING:
  - A) ALWAYS REPLACE NEW O-RINGS AND DISCARD OLD ONES.
  - B) REPLACE NEW LOCK WASHER WHEN RE-ASSEMBLING.

### **OIL SPECIFICATIONS**

- A) SHELL TELLUS 29.
- B) EXXON UNIVOLT 60/N61
- C) CHEVRON SUPERLA FDA APPROVED WHITE OIL

APPROX. QUANTITY PER PUMP IS 1.0 LITER.  
USE NON-CONDUCTING, NON-FOAMING FDA APPROVED OIL ONLY

### **ORDERING OF SPARE PARTS.**

PLEASE NOTE THE MANUAL AND DRAWINGS REFER TO THE FOLLOWING MODELS OF PUMPS:

- A] M304T/316SS
- B] M204T/316SS
- C] M154T/316SS
- D] M204S/T/316SS
- E] M154S/T/316SS

WHEN ORDERING SPARE PARTS PLEASE CLEARLY INDICATE THE PART NO. DEPENDING ON THE MODEL OF THE PUMP AND THE OUTLET SIZE AND TYPE.

CONFIRM VOLTAGE AND FREQUENCY OF PUMP MODEL.

**Illinois Location:**  
(847) 841-7867  
860 Church Rd Elgin, IL 61

**Minnesota Location:**  
(651) 758-7867  
330 Mill Bay South Suite  
Afton, MN 55001

PumpSupplyInc.com



**PS** **PUMP SUPPLY**  
INCORPORATED

**RECOMMENDED SPARES FOR TWO YEARS (ALL MODELS)**

- 1 DIFFUSER
- 1 IMPELLER
- 1 WEAR PLATE
- 1 'O' RING SET
- 1 SET OF BEARINGS
- 1 SET OF MECHANICAL SEALS
- 1 CABLE GROMMET
- 1 CABLE LEAD GROMMET

**Illinois Location:**

(847) 841-7867  
860 Church Rd Elgin, IL 60120

**Minnesota Location:**

(651) 758-7867  
330 Mill Bay South Suite  
Afton, MN 55001

PumpSupplyInc.com

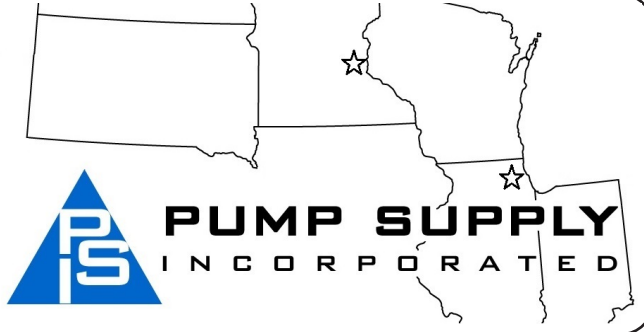



# MODY DUAL VOLTAGE, 3Ph-230/460v 9 LEAD WINDING DIAGRAM

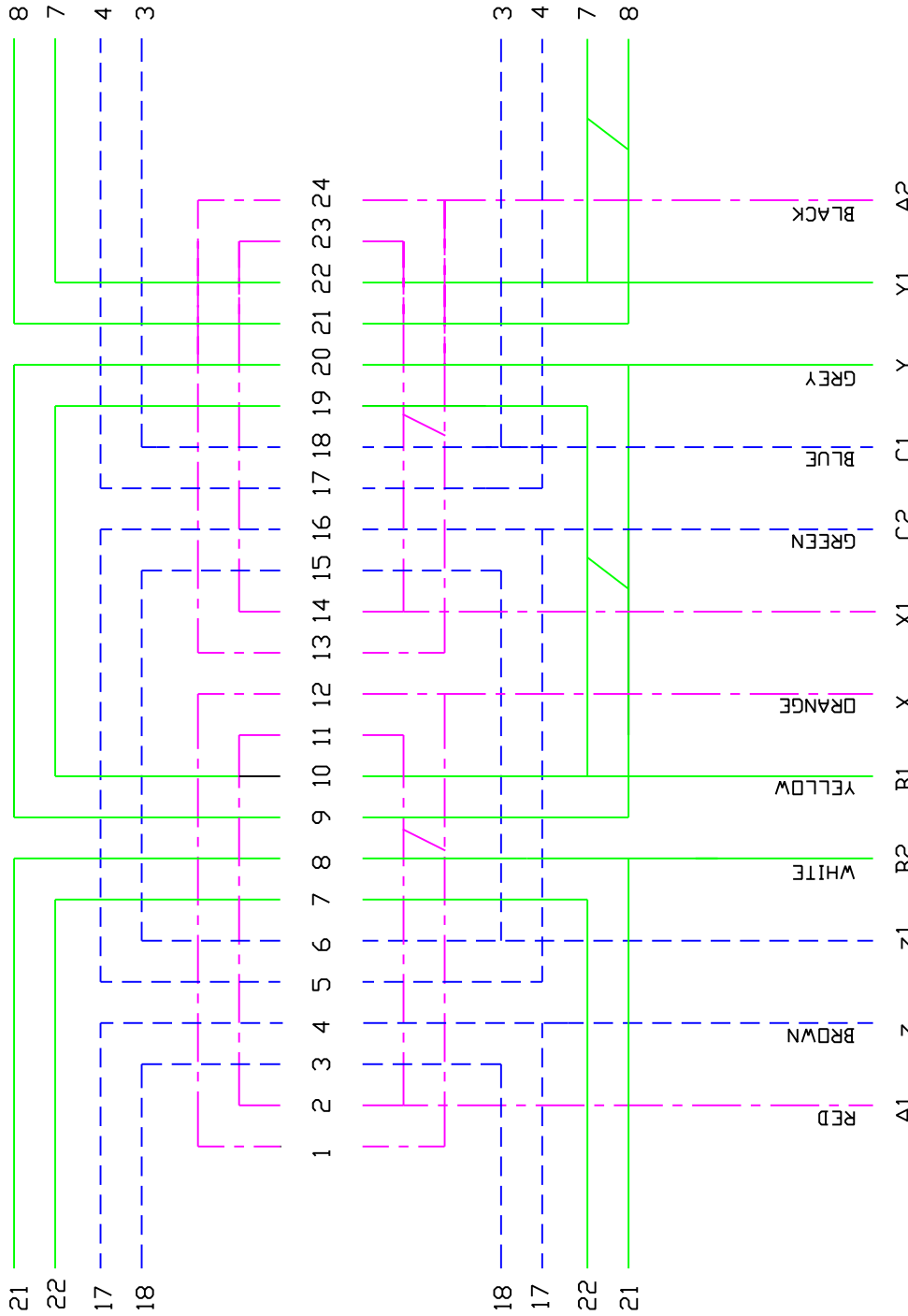

## 460 VOLT CONNECTION

JOIN A2 X - BLACK AND ORANGE  
 A2 Y - WHITE AND GREY  
 C2 Z - GREEN AND BROWN  
 POWER TO A1(RED), B1(YELLOW), C1(BLUE)

## 230 VOLT CONNECTION

SHORT XYZ  
 JOIN A1 A2 - RED AND BLACK-POWER  
 B1 B2 - YELLOW AND WHITE-POWER  
 C1 C2 - BLUE AND GREEN-POWER



POINTS X1 Y1 Z1 ARE PERMANENTLY SHORT CIRCUITED

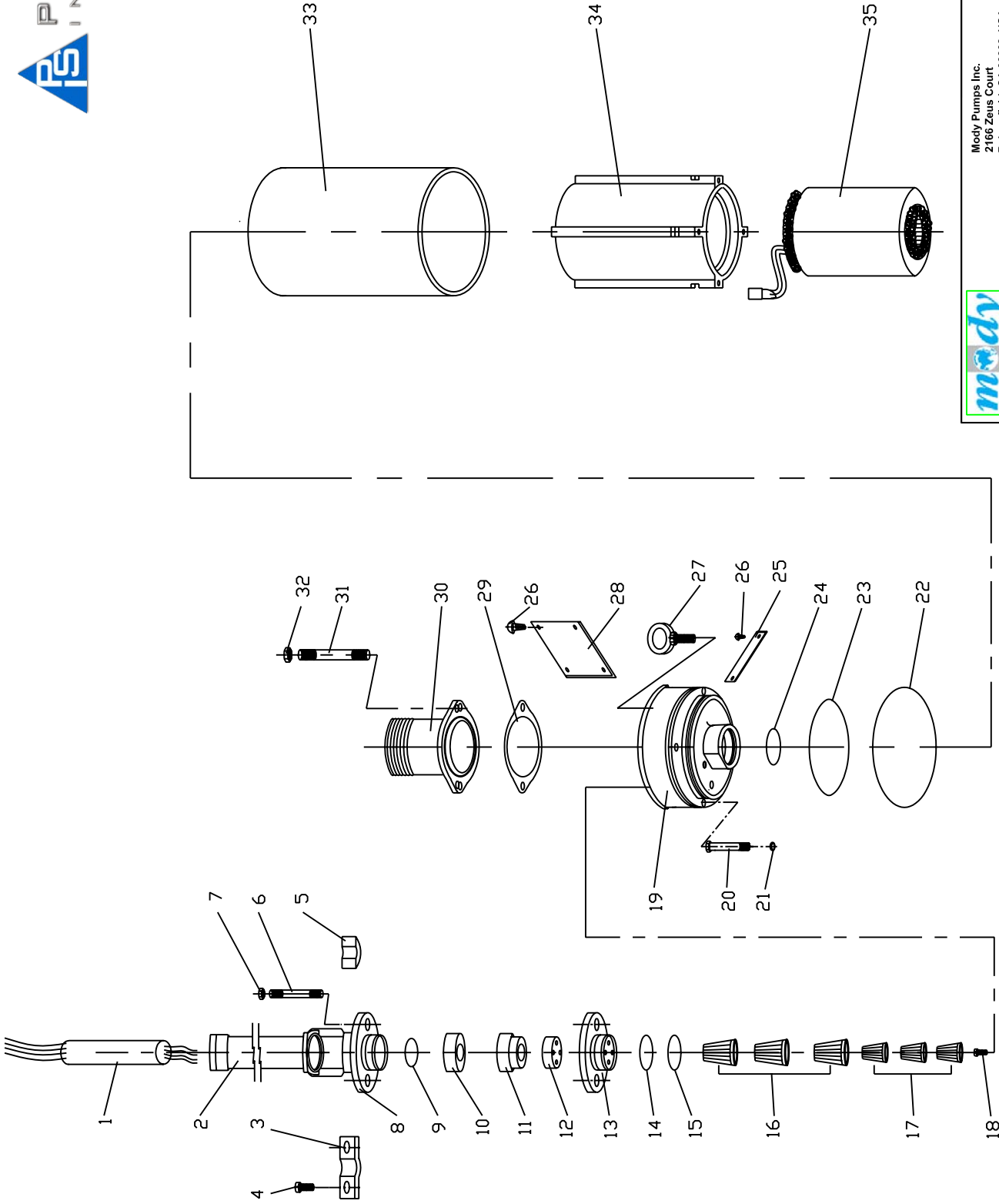

Moody Pumps Inc.  
2166 Zeus Court  
Bakersfield, CA 93308 USA  
Tel.: 661-392-7600 Fax: 661-392-7601  
www.moodypump.com

TYPE M304T/SS  
TITLE: EXPLODED VIEW WITH PART LIST OF MOODY SUBMERSIBLE PUMPS

DRN.	NAME	DATE
CHD.	D.M.GUTAL	8-9-2005
APPD.		
DRAWING No.		VER./REV
DW/208/00		1.0 / 00
		pt.

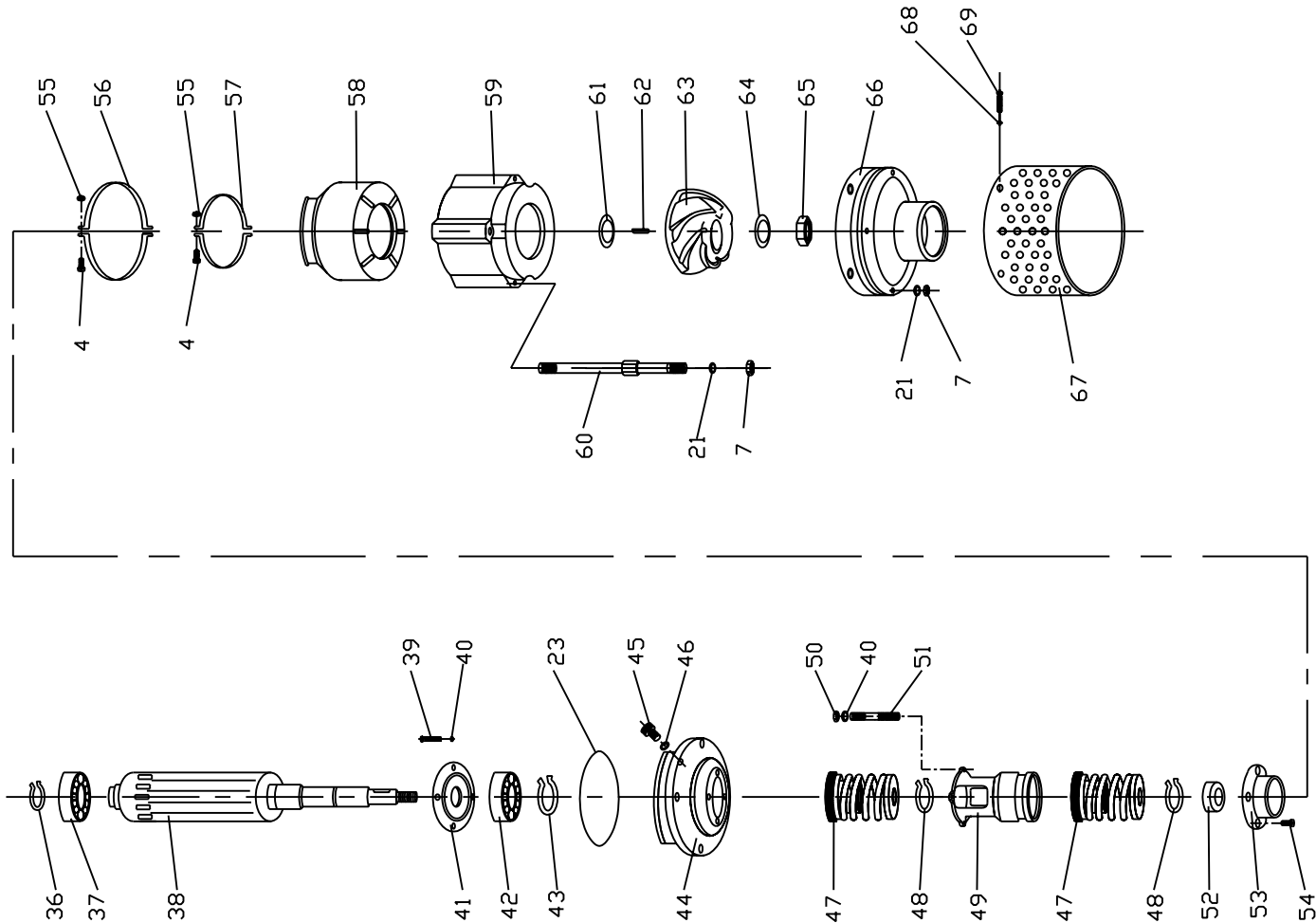

Mody Pumps Inc.  
2166 Zeus Court  
Bakersfield, CA 93308 USA  
Tel: 661-392-7600 Fax: 661-392-7601  
www.modypump.com

TYPE: M304T/SS  
TITLE: EXPLODED VIEW WITH PART LIST OF MODY SUBMERSIBLE PUMPS

DRN.	NAME	DATE
CHD.	D.M.GUTAL	8-9-2005
APPD.		
DRAWING No.		VER./REV
DW/208/00		1.0 / 00
		DT.

**MODY M304T/316SS VER 1.0**

<b>D.NO.</b>	<b>PART NO.</b>	<b>DESCRIPTION</b>	<b>QTY</b>
1	065-014-79	CABLE	50'
2	660-091-00	CABLE GRIP (order with grip)	1M
3	085-022-24	CABLE CLAMP	1
4	525-022-24	PH.PAN HD.SCREW	6
5	662-001-66	CABLE SUPPORT	1
6	650-013-24	STUD	2
7	370-006-24	HEX NUT	6
8	660-091-00	CABLE GLAND (order with grip)	1
9	380-006-66	"O" RING	1
10	260-035-66	CABLE GROMMET	1
11	600-016-24	CABLE GLAND SPACER	1
12	260-016-66	CABLE LEAD GROMMET	1
13	235-020-24	CABLE GLAND BASE	1
14	380-005-66	"O" RING	1
15	380-078-66	"O" RING	1
16	365-026-00	WIRE NUT CONNECTOR	3
17	365-027-00	WIRE NUT CONNECTOR	3
18	525-007-40	EARTHING SCREW	1
19	035-073-24	TOP BRACKET	1
20	045-015-24	HEX HD.BOLT	4
21	700-004-24	WASHER	12
22	380-030-66	"O" RING	1
23	380-025-66	"O" RING	2
24	380-012-66	"O" RING	1
25	635-010-21	ROTATION ARROW	1
26	465-006-21	RIVET	4
27	270-015-24	LIFTING HOOK	2
28	350-015-21	NAME PLATE	1
29	220-031-68	GASKET	1
30	405-095-24	OUTLET 3" NPT	1
31	650-012-24	STUD	2
32	370-006-24	HEX NUT	2
33	400-040-24	OUTER CASING	1
34	625-047-24	STATOR CASING	1
35	619-016-00	BARE STATOR (230/460v, 9 Lead)	1
36	080-003-80	CIRCLIP	1
37	020-002-07	UPPER BEARING	1
38	480-024-00	ROTOR COMPLETE	1
39	045-002-24	HEX HD BOLT	4
40	700-001-24	WASHER	8
41	037-002-24	BEARING COVER	1
42	020-006-07	LOWER BEARING	1
43	080-006-08	CIRCLIP	1
44	035-010-24	LOWER BEARING BRACKET	1
45	520-002-24	OIL PLUG	2
46	380-001-66	"O" RING	2
47a	535-015-00	MECHANICAL SEAL S/C vs S/C	2
48	080-005-24	CIRCLIP	2
49	545-011-24	SEAL HOUSING	1



**MODY M304T/316SS VER 1.0**

<b>D.NO.</b>	<b>PART NO.</b>	<b>DESCRIPTION</b>	<b>QTY</b>
50	370-004-24	HEX NUT	4
51	650-002-24	STUD	4
52	600-033-24	CAP FOR CIRCLIP	1
53	515-009-24	SAND GUARD	1
54	525-025-24	PH.PAN HD SCREW	4
55	370-002-24	HEX NUT	8
56	085-005-24	OIL BAG CLAMP BIG	1
57	085-004-24	OIL BAG CLAMP SMALL	1
58	150-003-66	OIL DIAPHRAGM	1
59	715-003-80	WEAR PLATE	1
60	660-039-00	STUD ASSY	4
61	600-012-24	TRIMMING SPACER	3
62	320-007-24	KEY	1
63	300-027-24	IMPELLER	1
64	695-004-24	LOCK WASHER	1
65	370-014-24	LOCK NUT	1
66	175-006-80	DIFFUSER	1
67	640-010-24	STRAINER	1
68	700-002-24	WASHER	4
69	045-003-24	HEX HD.BOLT	4

**Illinois Location:**

(847) 841-7867  
860 Church Rd Elgin, IL 61

**Minnesota Location:**

(651) 758-7867  
330 Mill Bay South Suite  
Afton, MN 55001

PumpSupplyInc.com





# LIMITED WARRANTY

On Behalf of *Mody Industries Pvt. Ltd.* (manufacturer) we warrant to our immediate customer and to the ultimate consumer that products of our manufacture will be free of defects in material and workmanship under normal use and service for the following time periods, when installed and maintained in accordance with our instructions.

PUMPS: One (1) year from date of installation or (18) months from date of shipment, whichever occurs first. As used herein, "the ultimate consumer" is defined as the purchaser who first uses the product after it's initial installation or, in the case for product designed for non-permanent installation, the first owner who uses the product. It is the purchaser's or any sub-vendor's obligation to make known to the ultimate consumer the terms and conditions of this warranty. This warranty gives you specific legal rights, and there may also be other rights which vary from state to state. In the event the product is covered by the Federal Consumer Product Warranties Law (1) the duration of any implied warranties associated with the product by virtue of said law is limited to the same duration as stated herein, (2) this warranty is a LIMITED WARRANTY, and (3) no claims of any nature whatsoever shall be made against us, until the ultimate consumer, his successor, or assigns, notifies us in writing of the defect, and delivers the product and/or defective part(s) freight prepaid to our facility or nearest authorized service station. Some states do not allow limitations on how long an implied warranty lasts, so the above limitation may not apply. **THE SOLE AND EXCLUSIVE REMEDY FOR BREACH OF ANY AND ALL WARRANTIES WITH RESPECT TO ANY PRODUCT SHALL BE TO REPLACE OR REPAIR AT OUR ELECTION, FOB POINT OF MANUFACTURE OR AUTHORIZED REPAIR STATION, SUCH PRODUCTS AND/OR PARTS AS PROVEN DEFECTIVE. THERE SHALL BE NO FURTHER LIABILITY, WHETHER BASED ON WARRANTY, NEGLIGENCE OR OTHERWISE.**

Unless expressly stated otherwise, guarantees in the nature of performance specifications furnished in addition to the foregoing material and workmanship warranties on a product manufactured by *Mody Industries Pvt. Ltd.*, if any, are subject to laboratory tests corrected for field performance. Any additional guarantees, in the nature of performance specifications must be in writing and such writing must be signed by our authorized representative. Due to inaccuracies in field testing if a conflict arises between the results of field testing conducted by or for user, and laboratory tests corrected for field performance, the latter shall control. Components or accessories supplied by us but manufactured by others are warranted only to the extent of and by the terms and conditions of the original manufacturer's warranty. **RECOMMENDATIONS FOR SPECIAL APPLICATIONS OR THOSE RESULTING FROM SYSTEMS ANALYSES AND EVALUATIONS WE CONDUCT, WILL BE BASED ON OUR BEST AVAILABLE EXPERIENCE AND PUBLISHED INDUSTRY INFORMATION. SUCH RECOMMENDATIONS DO NOT CONSTITUTE A WARRANTY OF SATISFACTORY PERFORMANCE AND NO SUCH WARRANTY IS GIVEN.**

This warranty shall not apply when damage is caused by (a) improper installation, (b) improper voltage, (c) lightning, (d) sand or other abrasive materials, (e) scale or corrosion build-up due to excessive chemical content. Any modification of the equipment will also void the warranty. We will not be responsible for loss, damage or labor cost due to interruption of service caused by defective parts. Neither will we accept charges incurred by others without our prior written approval. This warranty is void if our inspection reveals the product was used in a manner inconsistent with normal industry practice and/or our specific recommendations. The purchaser is responsible for communication of all necessary information regarding the application and use of the product. **UNDER NO CIRCUMSTANCES WILL WE BE RESPONSIBLE FOR ANY OTHER DIRECT OR CONSEQUENTIAL DAMAGES, INCLUDING BUT NOT LIMITED TO LOST PROFITS, LOST INCOME, LABOR CHARGES, DELAYS IN PRODUCTION, IDLE PRODUCTION, WHICH DAMAGES ARE CAUSED BY ANY DEFECTS IN MATERIAL, AND/OR WORKMANSHIP AND/OR DELAYS IN SHIPMENT. THIS WARRANTY IS EXPRESSLY IN LIEU OF ANY OTHER EXPRESS OR IMPLIED WARRANTY, INCLUDING ANY WARRANTY OF MERCHANTABILITY OR FITNESS FOR A PARTICULAR PURPOSE.**

No rights extended under this warranty shall be assigned to any person, whether by operation or otherwise, without our prior written approval.

**Mody Pumps Inc.:** 2166 Zeus Court, Bakersfield, CA 93308 Tel.: (661) 392-7600 Fax: (661) 392-7601