

**MP PUMPS HTW SERIES****TEMPUFLO****INSTRUCTION BULLETIN  
HTW300**

Read this bulletin in full before installing, operating or servicing this pump. If any of the warnings of this bulletin are ignored serious injury or death could occur.

**WARNING!**

If any of the items listed below are violated, serious injury or death from burns caused by hot water may occur.

Do not perform service or maintenance when pumping system is pressurized or hot.

Do not operate the pump in a manner that it was not intended to be used.

Do not install for use in an open environment where people are present.

Do not install in a rigid piping system that does not allow the pipe to expand and cause the pump to be strained.

Do not allow severe temperature changes to occur in a short time period within the pumping system.

Do not operate beyond the pressure or temperature limits stated in the product literature, see pressure temperature curve.

Do not mount pump in conditions that high piping loads exist on the pump flanges.

Do not continue to operate the pump when unusual noise or vibration occurs.

Do not continue to operate the pumping system when a known leak exists or the system starts to smoke.

**Illinois Location:**

(847) 841-7867  
860 Church Rd Elgin, IL 61

**Minnesota Location:**

(651) 758-7867  
330 Mill Bay South Suite  
Afton, MN 55001

PumpSupplyInc.com



# MP PUMPS HTW SERIES

## APPLICATION AND INSTALLATION INSTRUCTIONS

It is important that this Instruction Bulletin be read carefully to fully familiarize yourself with the pump assembly arrangement. The instructions contained herein pertain to installation and maintenance of the pump assembly only. Check unit carefully to make certain that no parts are missing or have been broken in shipment. Any questions call 800-563-8006 or visit [mppumps.com](http://mppumps.com)

### INSTALLATION

1. The pump must be installed in a horizontal shaft position.
2. The housing may be rotated to a horizontal or vertical discharge to fit the particular piping installation.
3. Rigid and supported piping must be used that will not strain the pump housing when temperature changes are made during the use of the pump.
4. The piping system must be free of foreign material before start up.
5. Pipe thread sealing compound must be used on the NPT flanges that is compatible with the fluid being pumped and is rated for the temperature requirements.
6. The installation should permit adequate circulation of air to provide proper cooling of the motor and pump seal.
7. Do not install in a sealed enclosure or insulate the pump adapter and motor. The motor and/or pump seal may fail from excessive heat.
8. A good installation will have an enclosure that provides adequate air flow of ambient air to the motor of the pump.

### OPERATION AND MAINTENANCE

Any system leak should be repaired immediately.

Ideal mechanical seal life is 20,000 hours. Reduced seal life may be experienced from extreme conditions.

Once disassembled check the impeller and other wear items for unusual wear. Replace if necessary.

When servicing the pump, care should be taken that the pump has cooled to a sufficient temperature to permit disassembly. Operating personnel should be warned to exercise care and utilize eye and skin protection when servicing the pump.

### START-UP

1. Fill pumping system with fluid before start-up.
2. Check for leaks before insulating the piping system.
3. Check for proper shaft rotation by jogging the power and observing the fan clamp. Rotation arrows are provided on the pump housing.
4. The seal cavity inside the pump will internally vent during fill and start-up.
5. A small amount of fluid may leak from the seal cavity at the shaft; this is normal for a new installation and will stop after approximately one hour.
6. Do not allow the pump to run dry, or continue to operate the pump when it is noisy, vibrating, or leaks are observed. These noticeable signs give a warning that something is wrong with the equipment and must be investigated to avoid possible damage or injury from burns caused by hot fluids.



**PUMP SUPPLY  
INCORPORATED**

#### **Illinois Location:**

(847) 841-7867

860 Church Rd Elgin, IL 60123

#### **Minnesota Location:**

(651) 758-7867

330 Mill Bay South Suite 1511 Afton, MN 55001

[PumpSupplyInc.com](http://PumpSupplyInc.com)

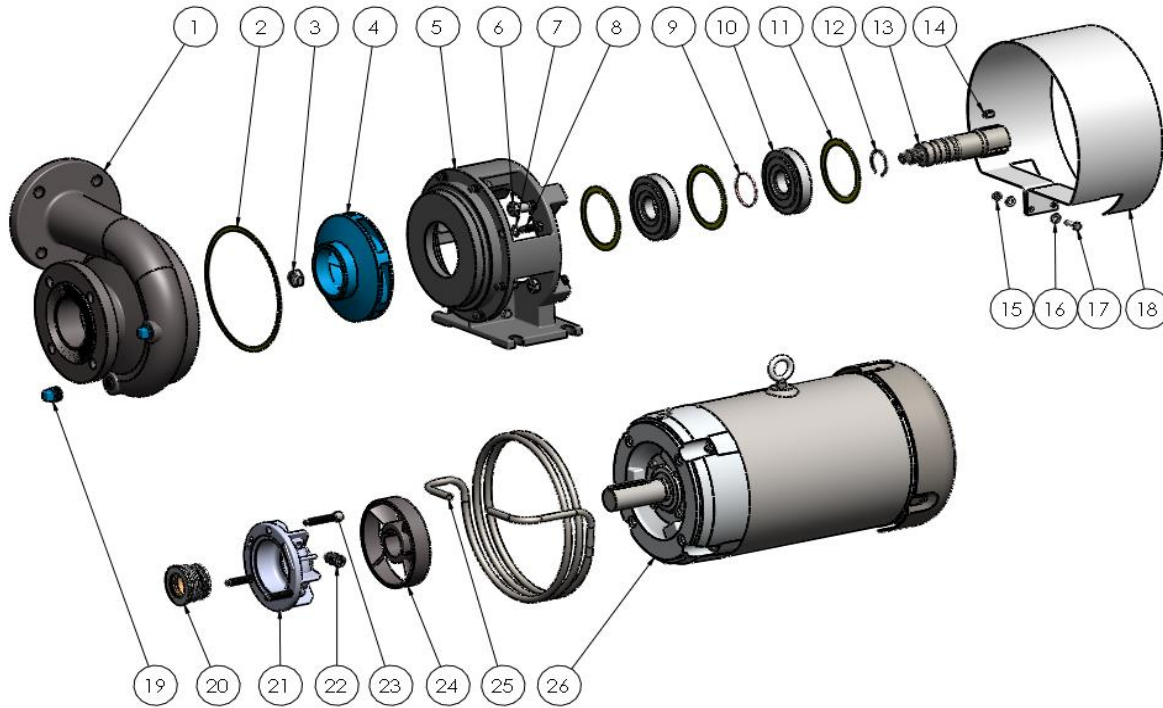

ITEM NO.	PART NUMBER	DESCRIPTION	MATERIAL	QTY.
1	26733	HOUSING	DUCTILE IRON	1
2	36662	GASKET	KLINGER TOP-SIL	1
3	25168	HEX JAM NUT 5/8-18	STEEL	1
4	30837	IMPELLER	CAST IRON	1
5	36660	ADAPTOR	DUCTILE IRON	1
6	41279	CAPSCREW 1/2-13X2	STEEL	4
7	30626	LOCKWASHER	STEEL	8
8	41256	CAPSCREW 3/8-16X1	STEEL	8
9	30841	O-RING	VITON	1
10	30842	ISOLATOR	CG	2
11	36661	GASKET	KLINGER TOP-SIL	3
12	29826	SNAP RING	STEEL	1
13	29822	DRIVE SLEEVE	303 STAINLESS	1
14	29831	SQUARE KEY	STEEL	1
15	21241	HEXNUT 1/4-20	304 STAINLESS	2
16	27261	WASHER	STEEL	4
17	33563	CAPSCREW 1/4-20X1	304 STAINLESS	2
18	36652	SHIELD	STEEL	1
19	41479	PIPE PLUG 1/2 NPT	CAST IRON	2
20	34933	SEAL ASSEMBLY	CSC/VITON	1
21	36639	HOUSING SEAL	DUCTILE IRON	1
22	36646	ADP FITTING	304 STAINLESS	2
23	39600	CAPSCREW 3/8-16X2	304 STAINLESS	3
24	29833	CLAMP FAN ASSEMBLY	DUCTILE IRON/STEEL	1
25	36635	HEAT EXCHANGER COIL	304 STAINLESS	1
26	31294	ELECTRIC MOTOR	TEFC	1



## MP PUMPS HTW SERIES

### ASSEMBLY INSTRUCTIONS

1. Lube the seal seat # 20 with MS-180 LUBRICANT, then press the seat into the seal housing # 21.
2. With the threaded end of the drive sleeve # 13 up, place the seal housing # 21 on the drive sleeve with the seal seat facing up.
3. Lubricate the rotating portion of the seal with MS-180 LUBRICANT and slide it over the drive sleeve.
4. Install the snap ring # 12 into the groove on the drive sleeve # 13.
5. Install the adapter fitting # 22 into the seal housing # 20. Use teflon based sealant on the threads.
6. Place housing # 1, suction down, and place the adapter # 5 into the housing. Instal the (3) gaskets # 11, (2) graphite isolators # 10 and o-ring # 9 onto the adapter.
7. Place the seal housing assembly into the adapter # 5 and install (3) capscrews # 23 thru the seal housing and into the adapter. Torque the capscrews to 20 ft. lbs. in increments of 5.
8. Apply Loctite onto the drive sleeve threads and install the impeller # 4 by threading it onto the drive sleeve. Make sure that the impeller shoulders against the sleeve.
9. Position the gasket # 2 onto the adapter # 5. Install the housing # 1 to the adapter using (8) cap-screws # 8 and (8) lockwashers # 7.
10. Place ferrule fitting side of # 22 onto both sides of heat exchanger coil # 25. Place heat exchanger and ferrule into both sides of the seal housing. Make sure that the coil shoulders up against the 1/8" NPT side of the ferrule fitting. Make the ferrule finger tight. Mark the ferrule nut in the 9 o'clock position, then rotate the ferrule 1-¼ turns so that the mark is in the 12 o'clock position.
11. Slide the fan clamp # 24 onto the sleeve with the blades closest to the seal housing. The pump end assembly (Pumpak) is complete.
12. Pumpak assembly to the motor as follows.
  - a. Slide the pumpak onto the motor and tighten (4) 1/2-13 capscrews on the motor flange.
  - b. Reaching through the inlet of the pump, push the impeller back towards the motor until it stops (impeller will contact the isolator to set the seal at the proper working height) movement is about .25 inches.
  - c. Tighten the capscrews in the fan clamp # 24 while holding the impeller in this position.
  - d. Rotate impeller to check for contact with stationary parts.

**Illinois Location:**  
(847) 841-7867  
860 Church Rd Elgin, IL 61

**Minnesota Location:**  
(651) 758-7867  
330 Mill Bay South Suite  
Afton, MN 55001

PumpSupplyInc.com





**PUMP SUPPLY**  
INCORPORATED

**Illinois Location:**  
(847) 841-7867  
860 Church Rd Elgin, IL 60120

**Minnesota Location:**  
(651) 758-7867  
330 Mill Bay South Suite  
Afton, MN 55001

PumpSupplyInc.com





**PS** **PUMP SUPPLY**  
INCORPORATED

**Illinois Location:**  
(847) 841-7867  
860 Church Rd Elgin, IL 60120

**Minnesota Location:**  
(651) 758-7867  
330 Mill Bay South Suite  
Afton, MN 55001

PumpSupplyInc.com



The logo for Pump Supply Incorporated features a blue triangle on the left containing the white letters 'PS'. To the right of the triangle, the words 'PUMP SUPPLY' are written in a large, bold, black sans-serif font, with 'INCORPORATED' in a smaller, spaced-out, black sans-serif font below it. The entire logo is overlaid on a map of Illinois and Minnesota, with a star in each state indicating a location.