

End Suction Centrifugal GS Series

EBARA Pumps Americas Corporation



Operating Instructions, Installation & Maintenance Manual

Illinois Location:

(847) 841-7867
860 Church Rd Elgin, IL 60123

Minnesota Location:

(651) 758-7867
330 Mill Bay South Suite 1511
Afton, MN 55001



PumpSupplyInc.com



Illinois Location:
(847) 841-7867
860 Church Rd Elgin, IL 60123

Minnesota Location:
(651) 758-7867
330 Mill Bay South Suite 1511
Afton, MN 55001

PumpSupplyInc.com



End Suction Centrifugal



Contents

- 1. INTRODUCTION.....4
- 2. SAFETY.....4
 - 2.1 PREPARATION AND TRAINING OF STAFF
 - 2.2 MAINTENANCE
- 3. TRANSPORT AND STORAGE.....5
- 4. SPECIFICATIONS.....5
- 5. OPERATING LIMITS.....6
- 6. INSTALLATION.....7
 - 6.1 INSTALLATION POINT
 - 6.2 LIFTING
 - 6.3 CEMENTED BASE
 - 6.4 PIPES
 - 6.5 ALIGNMENT
 - 6.6 ELECTRICAL SYSTEM
 - 6.6.1 ELECTRICAL CONNECTION
 - 6.6.2 ELECTRICAL MAINTENANCE
- 7. OPERATION.....12
 - 7.1 BEFORE STARTING THE PUMP
 - 7.2 STARTING THE PUMP
 - 7.3 STOPPING THE PUMP
- 8. MAINTENANCE.....13
 - 8.1 DAILY INSPECTION
 - 8.2 PRECAUTIONS DURING OPERATION
 - 8.3 PRECAUTIONS DURING STORAGE
 - 8.4 REPLACING PARTS
 - 8.5 TROUBLESHOOTING
 - 8.6 RESIDUAL RISKS
- 9. CONSTRUCTION.....20
- 10. DISMANTLING AND FITTING.....22
- 11. REPAIR AND WARRANTY.....22



End Suction Centrifugal



1. INTRODUCTION

Thank you for choosing this EBARA GS model pump. This operating manual describes the correct installation, operation and maintenance procedures of the product. EBARA pays great attention to the manufacturing of its products so that their use by end-users may be as safe as possible. However, using this pump improperly may reduce its operating performance and lead to personal injury and damage to property.

All our devices are delivered after being checked at our own plant and so they are in a condition to operate correctly after being connected to the power supply and the water system, as shown in this manual.

When this device is delivered:

1. Check the nameplates. It is very important to check the voltage rating for the pump. Also, check the value of the head, the capacity and the Rotation speed of the pumps, as well as the motor output.
2. Double check the equipment to make sure there is no damage generated during the startup and that there are no loose screws or mountings.
3. Check that all the accessories, spare parts and required options are included within the supply.

We recommend that you keep this manual in a safe place so that it may be consulted whenever needed.

2. SAFETY

This instruction and maintenance manual includes the basic instructions that should be taken into consideration during installation, operation and maintenance of the equipment.



Generic Hazard

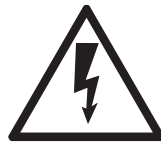

Electrical Voltage

It is essential that the worker/installer reads all the sections in this manual carefully before installation and operation. We recommend that you keep this manual in the place where you plan to install the equipment. In addition to the safety instructions found in this manual, it is also necessary to take into account the safety regulations and standards in force in the country where you want to use the equipment, in order to achieve greater protection.

Disregarding the safety instructions shown in this manual may lead to risks to persons and equipment.



EBARA PUMPS AMERICAS CORPORATION

www.pumpsebara.com

(t) 803.327.5005

(f) 803.327.5097

End Suction Centrifugal



2.1 PREPARATION AND TRAINING OF STAFF

The personnel involved in the installation, operation, maintenance and control of the equipment must be properly trained so as to carry out their tasks as effectively as possible. The responsibility, skills and supervision of the personnel fall within the remit of the employer. If the staff do not have the appropriate knowledge, they must be duly trained. If required, the employer may receive proper training directly from EBARA or from the distributor of this equipment.

2.2 MAINTENANCE

No technical or structural changes to the equipment are permitted without prior approval from EBARA. Only genuine spare parts and accessories authorized by EBARA are suitable for meeting safety standards. Rebuilding, modifying or using other spare parts may lead to the invalidation of your warranty.

Sound operation of the equipment depends on whether it is being used in accordance with the instructions given in this instruction manual. The working conditions and limits set out in this manual may not be exceeded in any way.

Always keep the nameplates legible and in good condition because the details shown will be needed for future reference or to request spare parts.

3. TRANSPORT AND STORAGE

If necessary, the equipment must be handled and stored in appropriate packaging. It must not be stored in damp environments with strong variations in temperature or in corrosive atmospheres. Condensates may attack the seal areas, metal parts and its electrical operation. In this case, any claims made under the warranty will be refused.

4. SPECIFICATIONS

Pump Tag:

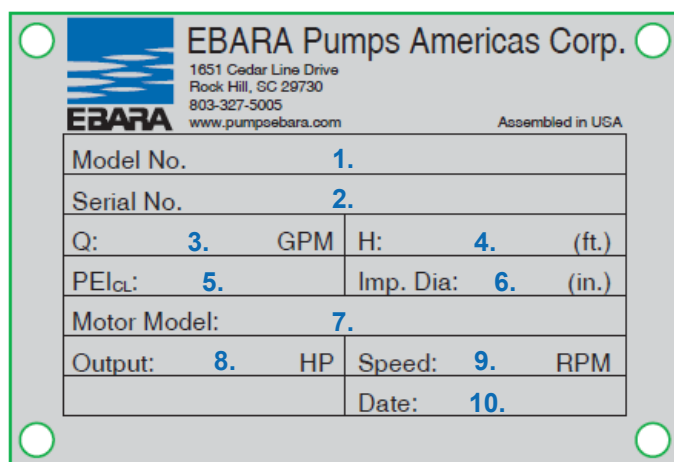

1. Product code
2. Serial number
3. Flow rate
4. Head
5. PEI Value
6. Impeller Diameter
7. Motor Model
8. Motor HP
9. Motor Rotational Speed
10. Assembly Date



End Suction Centrifugal



Its applications include climate control and building services, water supply, industry, etc. Other specifications are shown in the following table:

Pump body in cast iron ASTM A48 CL35

Description		Standard
		2 and 4 poles
Liquid	Temperature	14 to 212°F
	Density	in accordance with requirements
	Viscosity	in accordance with requirements
Maximum operating pressure		200 PSI (13.8 Bar)
Construction	Impeller	Closed
	Seal	Mechanical
		Carbon/Ceramic
Bearings		Shielded ball bearings
Flange		ANSI B16.1-125# FF
Material	Pump body	Cast iron ASTM A48 CL35
	Impeller	Cast iron ASTM A48 CL35
	Shaft	AISI 431 stainless steel
	Casing ring	420 SS
	O-ring/elastomer	Buna

5. OPERATING LIMITS

Unless EBARA has been previously notified, in general, the equipment must be mounted inside (below roof level), in adequately ventilated rooms and where access is restricted to authorized personnel, in addition to working within the following limits:

- **Ambient temperature:** must not exceed 104°F and the average temperature over 24 hours must not be above 95°F. The minimum air temperature in the space will be 39°F.
- **Humidity:** humidity must not exceed 50% and a temperature of 104°F. Higher humidity levels can be accepted at very low temperatures.
- **Pollution:** the air inside the aforesaid space must be clean and non-corrosive or, failing that, the pollution level must be low and electrically non-conductive through condensation.
- **Altitude:** the altitude where the pump is installed must not exceed 1000m/3300ft.

If the conditions of use are different from those indicated, EBARA must be notified of these conditions; such as installation outdoors or in places open to the public; any temperature, humidity, and altitude values other than those described; heavy pollution due to dust, fumes, vapors or salt; exposure to strong magnetic or electrical fields; locations exposed to risks of explosion, mechanical vibrations and significant shocks.



EBARA PUMPS AMERICAS CORPORATION

www.pumpsebara.com

(t) 803.327.5005

(f) 803.327.5097

6

rev. 03/22

End Suction Centrifugal



6. INSTALLATION

6.1 INSTALLATION POINT

- (1) Install the equipment in an easily accessible place in order to carry out overhauls and maintenance.
- (2) Prohibit access to unauthorized persons by using related closure points.
- (3) Place the equipment as close as possible to the water supply, making sure that the difference in height between the water surface and the pump shaft is minimal and that the length of the suction pipe is as short as possible.
- (4) The sum between the suction pressure and the gauge pressure of the pump must always be less than the minimum permissible pressure (see section 4 - Specifications).

6.2 LIFTING

In order to move the electric pump or the individual pump you must lift the load by means of straps, creating an angle of less than 60 degrees, as shown in the figure:

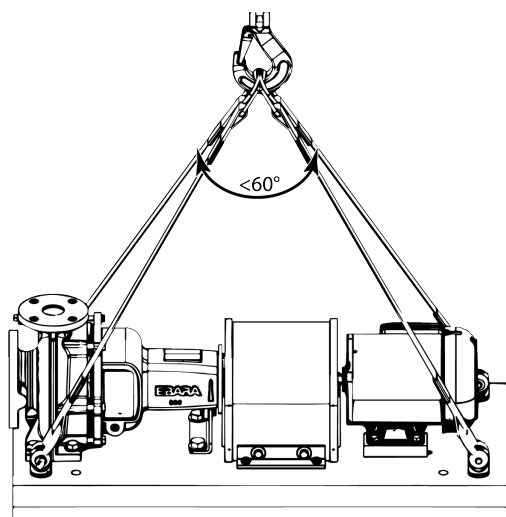

Ensure that there are no personnel exposed to danger during the operation. To lift the assembly, do not use the attachment points of the motor or the pump because they may not have been designed to bear the combined weight of the pump, motor and base.

6.3 CEMENTED BASE

One should note that electric pump units must be fixed in a stable and durable manner to a solid cemented base so that the axes of the pumps and the motors always remain correctly and securely aligned. The cement base must be sufficiently rigid, permanent and aligned, as well as being located on ground capable of bearing a permitted load of adequate support facilities. The top part of the unit must rest completely on the cemented base; once the top part has been secured, the alignment of the coupling needs to be checked again.

If you need to limit, as much as possible, the vibrations of the equipment by using elastic dampers, the latter should not be placed directly under the metal profiles, but instead, you will need to produce a solid plate with a weight of one and a half times or two times the overall weight of the unit, arranging the dampers under the assembly that combines the top part with the plate. There are several valid methods although this plate is typically made with concrete and its dimensions exceed those of the top by about 1.875" (0.2 meters) on all four sides.



EBARA PUMPS AMERICAS CORPORATION

www.pumpsebara.com

(t) 803.327.5005

(f) 803.327.5097

7

rev. 03/22

End Suction Centrifugal



Generally, an incorrect cement base is the cause of premature failure and this invalidates the warranty period.

6.4 PIPES

The installation must be done according to the arrangement shown in the Figure:

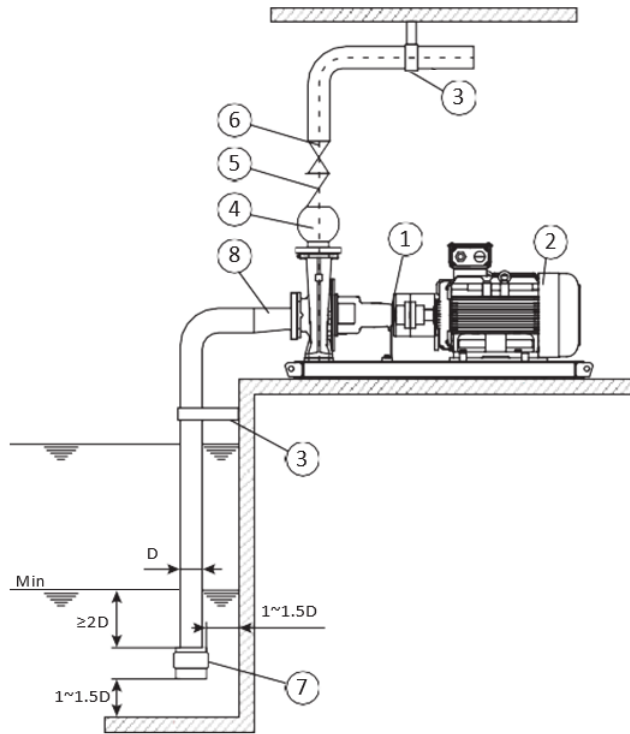

1	Pump
2	Motor
3	Mount
4	Elastic sleeve
5	Check valve
6	Shut-off valve
7	Bottom valve
8	Eccentric reduction

1. Make sure that the suction and delivery ducts do not transmit any stresses to the pump, by installing sufficiently strong supports. If this is not done, the pump could become misaligned and even break.
2. Fit any check valves (between the pump and the delivery valve) in the following cases:
 - In very long pipes.
 - If the head is high.
 - If the operation is automatic.
 - When you fill a tank under pressure.
 - When the operation is in parallel.
3. Mount air relief valves, if required, in those parts of the installation where it is impossible to avoid the formation of air bubbles. However, they must not be fitted at points where the pressure is less than atmospheric pressure since the valve would suck in air rather than expel it.
4. To reduce the effect of a water hammer, mount a check valve with spring.



EBARA PUMPS AMERICAS CORPORATION

www.pumpsebara.com

(t) 803.327.5005

(f) 803.327.5097

8

rev. 03/22

End Suction Centrifugal



5. Suction systems:

- The bottom end of the suction pipe must remain submerged and at a depth of at least twice the diameter of the pipe (2D) and at a distance from the bottom of 1 time to 1 and a half times the diameter (1~1.5 D).
- Fit a bottom valve with a filter at the beginning of the suction pipe to prevent the entry of any foreign bodies.
- The suction pipe will be installed with an upward gradient towards the pump (of more than 1%) to avoid the formation of air bubbles. The pipes and other accessories must be connected in such a way so as not to create any air intake between the different elements.
- Make sure that the suction pipe is as short and straight as possible and try to avoid any unnecessary curves or additional length. Do not install any shut-off valve in this section.
- Unless the installation project indicates something different, use the dimensions for the suction pipe and eccentric reduction recommended in this Table. The eccentric reduction will be installed with an upward gradient towards the pump to avoid the formation of air bubbles.

Suction x Discharge	2 Pole		4 Pole	
	Pipe Size	Reduction	Pipe Size	Reduction
50 x 32 2" X 1.25"	65 2.5"	65 x 50 2.5" x 2"	80 3"	80 x 50 3" x 2"
65 x 40 2.5" x 1.5"	80 3"	80 x 65 3" x 2.5"	100 4"	100 x 65 4" x 2.5"
65 x 50 2.5" x 2"	100 4"	100 x 65 4" x 2.5"	125 5"	125 x 65 5" x 2.5"
80 x 65 3" x 2.5"	125 5"	125 x 80 5" x 3"	150 6"	150 x 80 6" x 3"
100 x 80 4" x 3"	150 6"	150 x 100 6" x 4"	200 8"	200 x 100 8" x 4"
125 x 100 5" x 4"	200 8"	200 x 125 8" x 5"	250 10"	250 x 125 10" x 5"
150 x 125 6" x 5"	250 10"	250 x 150 10" x 6"	300 12"	300 x 150 12" x 6"

6. In systems where a booster pump is present:

- The installation of a shut-off valve is recommended in the suction pipe to facilitate dismantling and overhauls.
- Install the suction pipe with an upward gradient towards the pump to avoid the formation of air bubbles.



End Suction Centrifugal



6.5 ALIGNMENT

Pumps supplied with motors are connected to these through a simple elastic coupling or with a spacer. The pumps come on the market after being aligned within the production center; nevertheless, during installation, the top of the coupling assembly usually becomes misaligned due to anchoring with anchor pins. Therefore, the coupling needs to be adjusted by using shims underneath and aligning the pump while staying within the tolerances shown in the figure below.

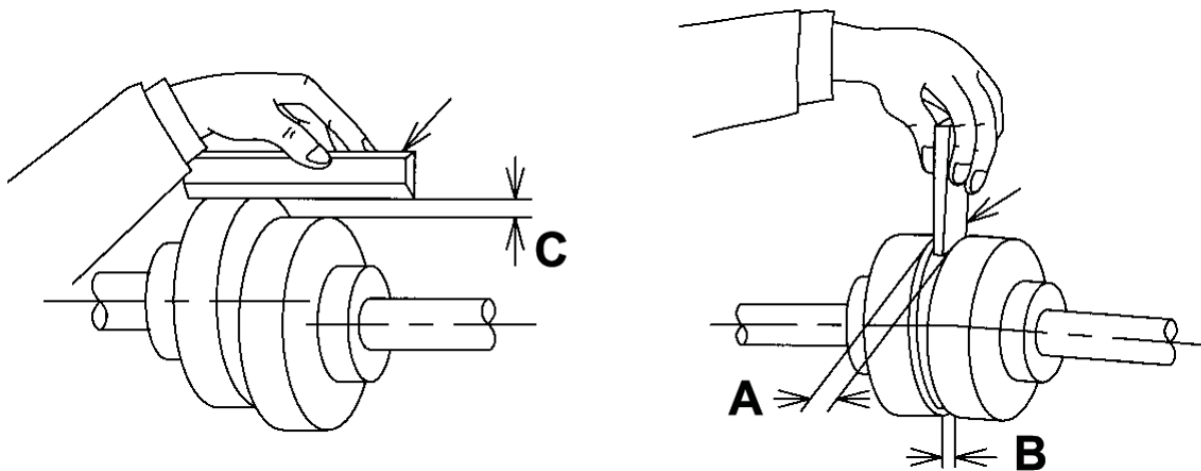

Dimension [mm]			
External diameter	C	A, B	A-B
1.85	< 0.063	0.03 - 0.13	< 0.03
2.32	< 0.063	0.04 - 0.16	< 0.04
2.6	< 0.063	0.05 - 0.18	< 0.05
3.13	< 0.063	0.06 - 0.22	< 0.06
3.65	< 0.063	0.06 - 0.22	< 0.06
4.48	< 0.094	0.08 - 0.23	< 0.08
5.42	< 0.094	0.1 - 0.28	< 0.1
6.63	< 0.094	0.12 - 0.35	< 0.12
8.13	< 0.094	0.14 - 0.43	< 0.14

size	B dimension	C		A, B [inch]		A-B [inch]
		inch	mm	Min	Max	
WE2	1.85	0.063	1.6	0.030	0.130	0.030
WE3	2.32	0.063	1.6	0.040	0.160	0.040
WE4	2.6	0.063	1.6	0.050	0.180	0.050
WE5	3.13	0.063	1.6	0.060	0.220	0.060
WE10	3.65	0.063	1.6	0.060	0.220	0.060
WE20	4.48	0.094	2.4	0.080	0.230	0.080
WE30	5.42	0.094	2.4	0.100	0.280	0.100
WE40	6.63	0.094	2.4	0.120	0.350	0.120
WE50	8.13	0.094	2.4	0.140	0.430	0.140



EBARA PUMPS AMERICAS CORPORATION

www.pumpsebara.com

(t) 803.327.5005

(f) 803.327.5097

End Suction Centrifugal



If the pump was purchased without a motor, but the intention is to connect one during installation, you will need to correct the shift of the coupling by inserting a plate under the feet of the motor, by adjusting the disparity according to the range shown in the Figure.

The alignment operation is achieved by removing the coupling guard, although this will need to be refitted carefully before starting up the pump.

The size of the coupling depends on the power and speed of the motor connected to the pump. For further information contact EBARA.

6.6 ELECTRICAL SYSTEM

Check that the motor is cooled properly, by leaving the air inlets and outlets unobstructed. Our recommendation is to install the equipment in a ventilated place away from any heat source.

The condensate drainage outlets must be located in the lower part of the motor. The drainage caps can only be removed when the motor is protected from the water.

6.6.1 ELECTRICAL CONNECTION

All electrical connections of the equipment must be carried out by qualified personnel with the power supply switched off.

- Use power supply cables that are adequately sized to carry the maximum current absorbed by the motor, in addition to the margin set by local requirements; this will avoid any overheating and/or voltage drops (voltage drops must be less than 5% during the start-up phase).
- Make sure the cables reach the terminal box with a curve that prevents water from getting in and running over them.
- The contact surfaces of the connections must be clean and protected against rust. Do not place any washers or nuts between the terminals on the motor and those providing access to the mains.
- Check the airtight sealing of the cable gland to ensure the degree of protection indicated on the nameplate.
- Avoid any mechanical stress being transferred to the motor terminals.
- Comply with the current and frequency limits indicated on the nameplate of the motor.
- A switch must be installed to prevent any accidents involving electrical discharges, and overload protection against power surges for motors with the aim of avoiding any damage due to overheating.



End Suction Centrifugal



6.6.2 ELECTRICAL MAINTENANCE

Any work on the motor must be carried out with the appliance switched off and after disconnecting the mains power supply.

- Check on a regular basis that the requirements regarding installation and electrical connections are complied with.
- It is recommended that bearings are replaced after three years.



7. OPERATION

7.1 BEFORE STARTING THE PUMP

1. Make sure that the pipes are flushed after the installation is completed, since any impurities may lead to faults, noise and excess wear around the mechanical closure and the other parts of the pump.
2. Check that the pump turns easily by spinning the shaft with your hand. If the movement is stiff or irregular, check the pump because the mechanical closure may be damaged, the gasket too tight or there might even be rust inside the pump.
3. Check the operating details of the motor, which are listed on the nameplate.
4. Do not operate the pump before priming it first. If the system is in suction mode, the pump and the suction pipe must be filled with water via the relevant device duly installed on the delivery pipe. If the suction is primed, the pump must be filled with water by opening the suction and delivery valves. Make sure that no air remains inside the pump, to do this, you need to rotate the shaft by hand.
5. Check the direction of rotation of the motor, as shown below:
 - Close the delivery and suction valves.
 - Switch on the motor for 1 or 2 seconds, then stop it.
 - Visually check that the direction of rotation is correct via the connection or the fan on the motor. The direction of rotation is indicated by an arrow on the pump body. Generally, it is clockwise (to the right) when the observer is facing the fan on the motor.
 - After removing the coupling guard, put it back immediately after checking the rotation.

Illinois Location:
 (847) 841-7867
 860 Church Rd Elgin, IL 60123

Minnesota Location:
 (651) 758-7867
 330 Mill Bay South Suite 1511
 Afton, MN 55001
 PumpSupplyInc.com

PUMP SUPPLY
 INCORPORATED



EBARA PUMPS AMERICAS CORPORATION

www.pumpsebara.com

(t) 803.327.5005

(f) 803.327.5097

12

rev. 03/22

End Suction Centrifugal



7.2 STARTING THE PUMP

1. Shut off the main delivery valve. Open the suction valve if it is closed.
2. Turn on and off the switch to start the motor once or twice, to ensure that there are no faults in the startup.
3. When the rotation speed remains stable at the nominal speed, gradually open the delivery valve.
4. Check that there are no significant variations in the pump pressure and in the current absorbed by the motor. Check that there are no significant vibrations and/or unusual noises.
5. Follow the same procedure during subsequent startups if the operating conditions are normal, observing the instructions in Chapter 8. Maintenance.

7.3 STOPPING THE PUMP

Before stopping the pump, you are advised to close the delivery valve gradually.

If the pump stops due to a sudden lack in the power supply, disconnect the motor switch. This will avoid the pump starting up again as soon as the power supply returns, thereby endangering staff.

8. MAINTENANCE

Maintenance operations must be performed by qualified personnel: an error may lead to damage caused by electrical discharge, fire or malfunctions that in turn could lead to an accident.

Make sure that the operating power switch is disconnected during maintenance; the pump could start up suddenly if it is in automatic mode.

If the liquid being pumped is hot water, keep at a safe distance until it has cooled down. Similarly, do not touch the surface of the motor without making sure that the temperature has dropped to a tolerable level.

8.1 DAILY INSPECTION

1. Significant variations in pressure, capacity, electricity, vibrations or noise may be a sign of a malfunction of the pump. Refer to section 8.5 "Troubleshooting". It is advisable to keep a daily register on the operating conditions to allow discovering any symptoms that may be the result of a potential failure.
2. The maximum temperature for the bearing is 104°F above the ambient temperature, with a maximum total limit of 176°F
3. Generally, the mechanical seal does not show any leaks. Sometimes, at the beginning of operation there is a small leak of water which then gradually decreases. If, during normal operation, there is a major leak of water, you need to replace the seal.

Illinois Location:
(847) 841-7867
860 Church Rd Elgin, IL 60123

Minnesota Location:
(651) 758-7867
330 Mill Bay South Suite 1511
Afton, MN 55001

PumpSupplyInc.com



PS **PUMP SUPPLY**
INCORPORATED



EBARA PUMPS AMERICAS CORPORATION

www.pumpsebara.com

(t) 803.327.5005

(f) 803.327.5097

13

rev. 03/22

End Suction Centrifugal



8.2 PRECAUTIONS DURING OPERATION

1. Operating the pump for a long period of time with the delivery valve closed may cause damage to some of the pump components due to overheating inside the pump.
2. Too many stops and starts can cause damage to the pump. Limiting the number of starts is recommended in line with the following:

$$N \leq 6 \quad \text{when} \quad P \leq 10 \text{ hp}$$

$$N \leq 4 \quad \text{when} \quad 15 \text{ hp} \leq P \leq 30 \text{ hp}$$

$$N \leq 3 \quad \text{when} \quad P > 30 \text{ hp}$$

N = startup/h

P = motor power

8.3 PRECAUTIONS DURING STORAGE

1. The pump body may fracture if the water inside freezes; insulate the pump or remove all the water from the inside.
2. If you have any spare pumps, you must perform test runs on them on a regular basis and keep them ready for use at all times.
3. When a pump remains off for a long period of time, you must take great care to prevent any oxidation on the surface of the bearing, shaft, coupling, etc.

8.4 REPLACING PARTS

Replace worn parts according to the following table:

Part	Condition	Replacement period
Mechanical seal	Water leakage	Yearly
Ball bearings	Excessive noise or vibration	Every 2 or 3 years
Pump body O-ring	After every dismantling	---
Coupling rubber parts	As soon as any signs of damage appear	Yearly

This replacement period is an average and refers to normal operating conditions.



EBARA PUMPS AMERICAS CORPORATION

www.pumpsebara.com

(t) 803.327.5005

(f) 803.327.5097

14

rev. 03/22

End Suction Centrifugal



8.5 TROUBLESHOOTING

Although the equipment usually functions according to the user's requirements, in some cases its operation may not come up to expectations due to problems with the system or the power supply. The following table may be useful in finding possible solutions in the event of failures or malfunctions:

PUMP

Fault	Causes	Measures to be taken
The motor will not start.	<ul style="list-style-type: none"> - The control panel is not working correctly. - Motor failure. - Faults in the power supply. - Friction on rotation shaft. - Pump clogged. 	<ul style="list-style-type: none"> - Check all conditions. - Repair the motor. - Check and repair. - Rotate it by hand. Reassemble. - Repair in specialist workshop. - Remove foreign bodies.
There is no priming.	<ul style="list-style-type: none"> - Foreign bodies in the bottom valve. - Malfunction in the bottom valve. - Water leakage from the suction pipe. - Air entering the suction pipe or seal. 	<ul style="list-style-type: none"> - Remove foreign bodies. - Replace the valve. - Check the suction pipe. - Check the suction pipe and mechanical seal.
The pump has no flow rate	<ul style="list-style-type: none"> - The pump does not turn. - The delivery valve is closed or half-closed. - The suction head is too low for the pump. 	<ul style="list-style-type: none"> - Check that the impeller is free. - Open the valve. - Check the project.
Low flow rate	<ul style="list-style-type: none"> - The direction of rotation is not correct. - Low rotation speed. - Low voltage. - Blocking in the bottom valve or in the filter. - Impeller is blocked. - Pipe clogged. - Air entering the system. 	<ul style="list-style-type: none"> - Correct the electrical connections. - Measure the RPM with a tachometer. - Check the power supply. - Remove foreign bodies. - Remove foreign bodies. - Remove foreign bodies. - Check and repair the suction pipe and shaft seal.



EBARA PUMPS AMERICAS CORPORATION

www.pumpsebara.com

(t) 803.327.5005

(f) 803.327.5097

15

rev. 03/22

End Suction Centrifugal



Fault	Causes	Measures to be taken
Low flow rate continued	<ul style="list-style-type: none"> - Leakage in the delivery pipe. - Impeller worn. - Significant head losses in the system. - Liquid temperature very high. The liquid is volatile. - Cavitation. 	<ul style="list-style-type: none"> - Check and repair. - Check the impeller. - Review the project. - Review the project. - Seek expert advice.
Water comes out initially and then stops abruptly.	<ul style="list-style-type: none"> - The pump has not been primed. - Air entering the system. - Air bubbles in the suction pipes. - The suction head is too high for the pump. 	<ul style="list-style-type: none"> - Prime the pump correctly. - Check and repair the suction pipe and shaft seal. - Vent the pipes. - Review the project.
Power surge	<ul style="list-style-type: none"> - The voltage is low or the imbalance between the phases is high. - The flow rate is too high or the head is too low. - Foreign bodies inside the pump. - The mechanical seal was not fitted correctly. - Bearings damaged. - Friction in the rotation areas. The shaft is bent. - The direction of rotation is not correct. - The density and/or viscosity level of the liquid is high. 	<ul style="list-style-type: none"> - Check the power supply. - Partially shut off the delivery valve. - Remove foreign bodies. - Fit it correctly. - Replace the bearings. - Repair in specialist workshop. - Check and correct the connection. - Review the project.
The bearings are overheating.	<ul style="list-style-type: none"> - Bearings damaged. - In operation for a long time with the valve closed or half-closed. 	<ul style="list-style-type: none"> - Replace the bearings. - Avoid such a situation; close the valve or stop the pump.



End Suction Centrifugal



Fault	Causes	Measures to be taken
Excessive operating vibration and noise.	<ul style="list-style-type: none"> - Fault in installation. - Bearings damaged. - Flow rate too high. - Flow rate too low. - Impeller is blocked. - The direction of rotation is not correct. - Friction in the rotation areas. The shaft is bent. - Cavitation. - Vibrations in the piping. 	<ul style="list-style-type: none"> - Check installation. - Replace the bearings. - Reduce the aperture of the delivery valve. - Increase the aperture of the delivery valve. - Remove foreign bodies. - Check and correct the connection. - Repair in specialist workshop. - Seek expert advice. - Reinforce the piping or fit an inverter
Excessive water leakage from the shaft seal.	<ul style="list-style-type: none"> - Defective fitting of the mechanical seal. - The mechanical seal is damaged. - Overpressure in delivery. - The shaft is bent. 	<ul style="list-style-type: none"> - Fit it correctly. - Replace the mechanical seal. - Review the project. - Repair in specialist workshop.

MOTOR

Fault	Causes	Measures to be taken
Motor does not start	<ul style="list-style-type: none"> - The winding is broken or has been cut. - Stator short-circuited. - Grounded. - The bearings are blocked. - The voltage is low. - Loss of phases in the power supply. 	<ul style="list-style-type: none"> - Repair in specialist workshop. - Repair in specialist workshop. - Repair in specialist workshop. - Repair the bearings. - Change the nominal voltage. - Check the power supply.



End Suction Centrifugal

GS Series

Fault	Causes	Measures to be taken
Abnormal noise or excessive vibrations.	<ul style="list-style-type: none"> - Operation without a phase. - Power surges. - Friction between the rotor and stator. - Obstructions in the cooling fan. - Fault in installing the motor. - Poor Star/Delta commutation. 	<ul style="list-style-type: none"> - Check the power supply. - Correct the power surges. - Align and/or replace the bearing. - Remove foreign bodies. - Connect the pump correctly. - Correct the cabling.
Motor overheating. Appearance of smoke and/or bad smell.	<ul style="list-style-type: none"> - High power surges. - Fan is blocked. - Wrong voltage. - The bearings are blocked. - Stator short-circuited. - Stator grounded. 	<ul style="list-style-type: none"> - Correct the power surges. - Release the fan. - Change the motor for one with the appropriate voltage. - Repair the bearings. - Repair in specialist workshop. - Repair in specialist workshop.
Low rotation speed.	<ul style="list-style-type: none"> - Low voltage. - Poor Star/Delta commutation. - Overloading. - Defective electrical connection. 	<ul style="list-style-type: none"> - Change the nominal voltage. - Correct the cabling. - Reduce the current. - Correct the electrical connections.

Illinois Location:
 (847) 841-7867
 860 Church Rd Elgin, IL 60123

Minnesota Location:
 (651) 758-7867
 330 Mill Bay South Suite 1511
 Afton, MN 55001

PumpSupplyInc.com





End Suction Centrifugal

GS Series

8.6 RESIDUAL RISKS



The use and maintenance of the following pieces of equipment may lead to risks beyond the capacity of the manufacturer and, therefore, the user must pay the utmost attention to maintenance work and the handling of the equipment. The following risks need to be considered:

Operation	Risk	Measures to be taken
Maintenance	<ul style="list-style-type: none"> - Burns - Damage caused due to it being empty or due to pressure - Damage caused by entrapment 	<ul style="list-style-type: none"> - Wait until the temperature goes down - Check the temperature before touching - Stop the pump and proceed very carefully - Stop the pump and proceed very carefully - Always fit protection guards - Keep your distance from rotating parts
Transport and lifting	- Impacts and falls	- Proceed with care

Illinois Location:
 (847) 841-7867
 860 Church Rd Elgin, IL 60123

Minnesota Location:
 (651) 758-7867
 330 Mill Bay South Suite 1511
 Afton, MN 55001

PumpSupplyInc.com

PUMP SUPPLY
INCORPORATED



End Suction Centrifugal



9. CONSTRUCTION

GSU Standard Construction Parts Reference

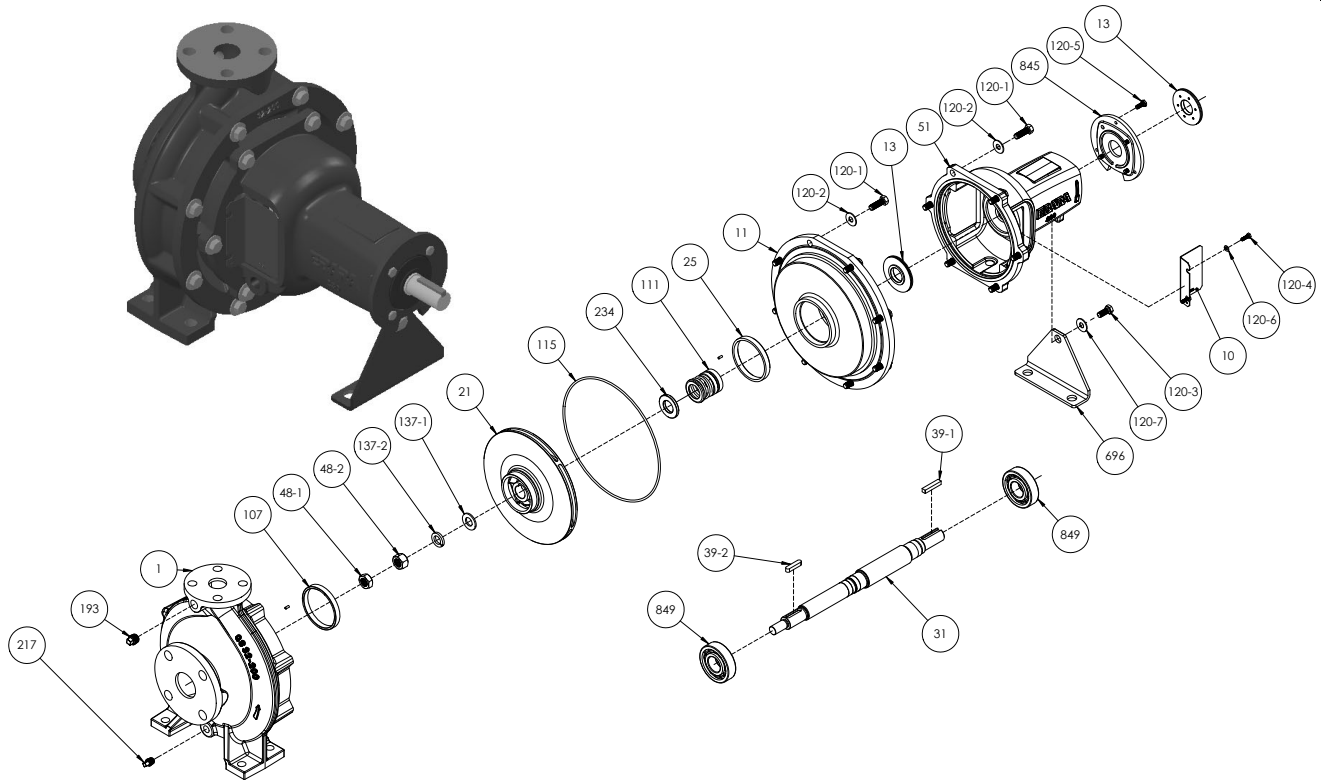

Num.	Name	Quant.
1	Casing	1
10	Pump Guard	2
11	Casing Cover	1
21	Impeller	1
31	Shaft	1
039-1	Key	1
039-2	Key	1
048-1	Impeller Nut	1
048-2	Impeller Nut	1
51	Bearing Housing	1
845	Bearing Cover	1
849	Ball Bearing	2
13	Deflector	2
696	Support Foot	1
107	Casing Wear Ring	1

Num.	Name	Quant.
25	Impeller Wear Ring	1
111	Mechanical seal	1
115	Casing O-ring	1
120-1	Casing Bolt	6
120-2	Nut and Washer	6
120-3	Bolt	1
120-4	Bolt	4
120-5	Bolt	1
120-6	Washer	4
137	Impeller washer	1
137-2	Lock Washer	1
234	Spacer Ring	1
193	Plug	1
217	Drain Plug	1
50	Spring Pin	2



EBARA PUMPS AMERICAS CORPORATION

www.pumpsebara.com

(t) 803.327.5005

(f) 803.327.5097

End Suction Centrifugal

GS Series

9. CONSTRUCTION ctd.



GSU Stud Type Construction Parts Reference

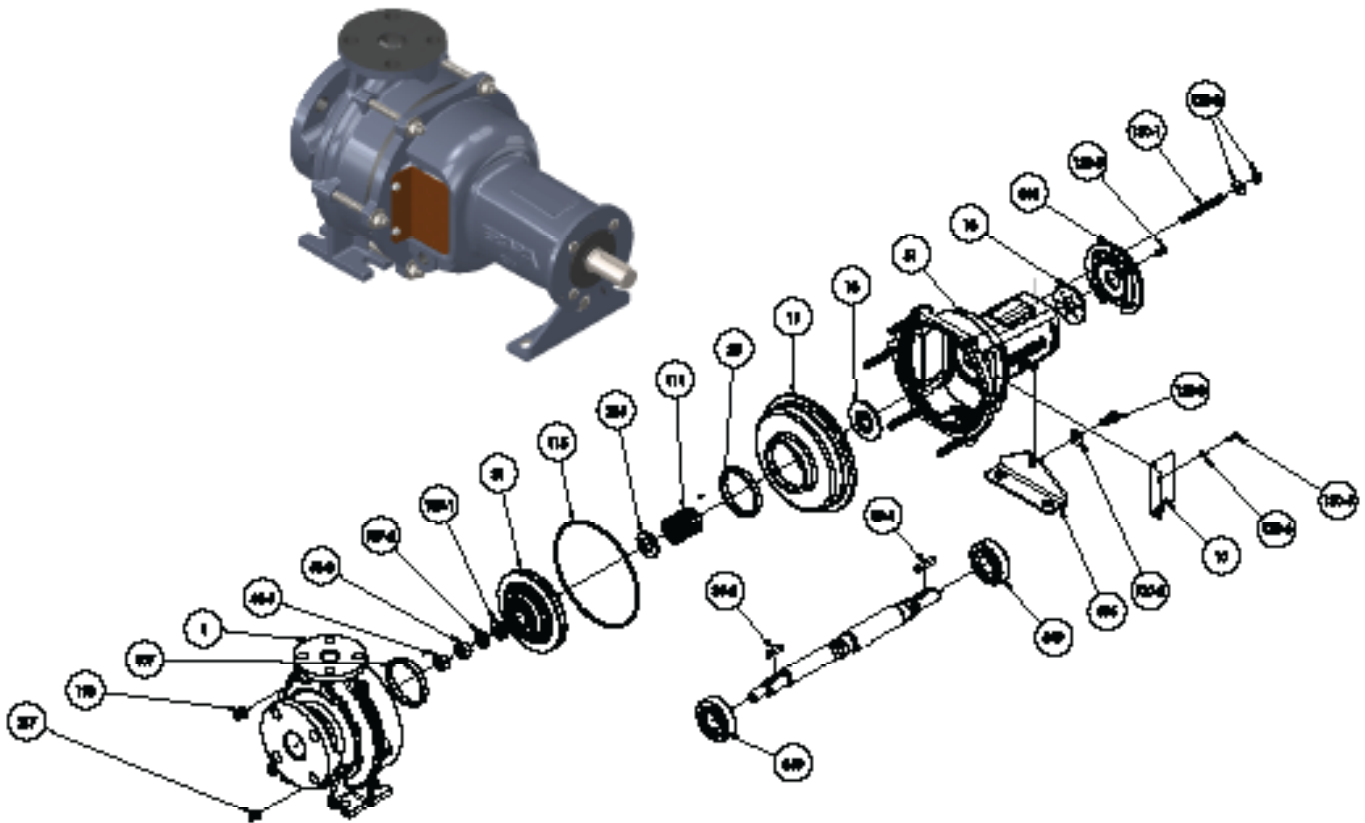

Num.	Name	Quant.
1	Casing	1
10	Pump Guard	2
11	Casing Cover	1
21	Impeller	1
31	Shaft	1
039-1	Key	1
039-2	Key	1
048-1	Impeller Nut	1
048-2	Impeller Nut	1
51	Bearing Housing	1
845	Bearing Cover	1
849	Ball Bearing	2
13	Deflector	2
696	Support Foot	1
107	Casing Wear Ring	1

Num.	Name	Quant.
25	Impeller Wear Ring	1
111	Mechanical seal	1
115	Casing O-ring	1
120-1	Stud	6
120-2	Nut and Washer	6
120-3	Bolt	1
120-4	Bolt	4
120-5	Bolt	1
120-6	Washer	4
137-1	Impeller washer	1
137-2	Lock Washer	1
234	Spacer Ring	1
193	Plug	1
217	Drain Plug	1
50	Spring Pin	2



EBARA PUMPS AMERICAS CORPORATION

www.pumpsebara.com

(t) 803.327.5005

(f) 803.327.5097

End Suction Centrifugal

GS Series

10. DISMANTLING AND ASSEMBLY

Assembly, disassembly, and repair of the pump, should only be performed by specialist maintenance technicians. Otherwise, error by personnel, can result in serious physical injury and/or equipment damage.



1. Before performing any installation or maintenance tasks:
 - Disconnect and lock-out power to the driver.
 - Make sure that all replacement parts, and tools are available
2. Use proper lifting method: The unit and the components can be heavy.
3. To prevent injury, allow all system and pump components to cool before handling.
4. To eliminate possible exposure to any hazardous or toxic fluids:
 - Identify contents in the pump.
 - Observe proper decontamination procedures.
 - Wear proper personal protective equipment (PPE).
 - Handle and dispose of pumped fluid in compliance with the applicable environmental regulations.
5. To avoid injury:
 - Wear appropriate gloves while handling parts. Some components can have sharp edges.



Illinois Location:
(847) 841-7867
860 Church Rd Elgin, IL 60123

Minnesota Location:
(651) 758-7867
330 Mill Bay South Suite 1511
Afton, MN 55001

PumpSupplyInc.com

Scan the QR Code to access the
Dismantling and Assembly Instructions



11. REPAIR AND WARRANTY

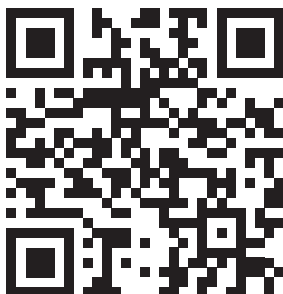

Illinois Location:
(847) 841-7867
860 Church Rd Elgin, IL 60123

Minnesota Location:
(651) 758-7867
330 Mill Bay South Suite 1511
Afton, MN 55001

PumpSupplyInc.com

Scan the QR Code to access the
EPAC Standard Warranty



EBARA PUMPS AMERICAS CORPORATION

www.pumpsebara.com

(t) 803.327.5005

(f) 803.327.5097

22

rev. 03/22