

EBARA



EBARA Pumps Americas Corporation

Submersible Wastewater, Sewage Pump

Model DLFU
Model DVFU
Model DDLFU



water | wastewater | flood control



Illinois Location:

(847) 841-7867
860 Church Rd Elgin, IL 60

Minnesota Location:

(651) 758-7867
330 Mill Bay South Suite 1
Afton, MN 55001

PumpSupplyInc.com

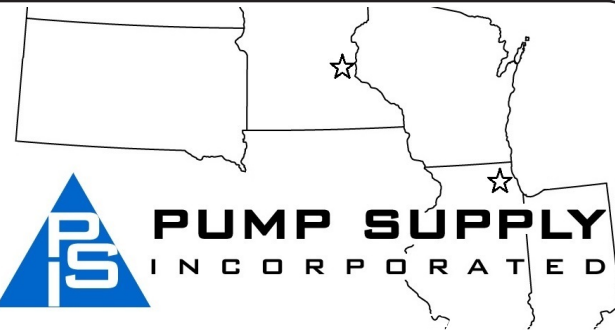

Model DLFU, DLKFU, DDLFU



Standard Specifications

Design	Discharge	2, 3, 4, 6, 8, 10, 12 inch
	Horsepower	2 to 60
	Capacity	13 to 4000 GPM
	Total head	7 to 243 feet
	Max.Liquid temp.	104°F/40°C
Speed		1800 RPM
Materials	Casing	Cast Iron
	Impeller	Cast Iron (2 to 60HP) Ductile Iron (150-300DLFU, 40 to 60HP)
	Shaft	403 Stainless Steel, 2 to 5HP 420 Stainless Steel, 7½ to 60HP
	Motor Frame	Cast Iron
	Fastener	304 Stainless Steel
Construction	Mechanical Seal	Double Mechanical Seal
	Material – Upper	Carbon/Ceramic <i>Optional:</i> Tungsten Carbide/Tungsten/Carbide
	Material – Lower	Silicon Carbide/Silicon Carbide, 2 to 60HP <i>Optional:</i> Tungsten Carbide/Tungsten/Carbide
	Impeller Type	Semi-open, 2 to 30HP Enclosed, 40 to 60HP
	Bearing	Prelubricated Ball Bearing
	Motor	2-5hp= Class F Insulation, 7.5-60hp= Class H Insulation <i>Optional:</i> FM Explosion Proof Class 1, Division 1, Group C, D
	Three Phase	208/230V, 460V
	Service Factor	1.15
	Motor Protection	Built-in Thermal Detector - Klixon Mechanical Seal Leakage - Float Switch
Submersible Cable		2 to 5HP - 33 ft. standard cable length 7½ to 60HP - 40 ft. standard cable length Optional _____ ft. (customer specified)
Accessories		Optional QDC System

K-Series, Model DLKFU – Features

Model DLKFU series pumps are designed to tackle clogging challenges with enhanced passage capabilities for handling of fibrous waste. The design features address the most common reasons for clogging caused by fibrous materials:

- Reduces material caught on the vane tips
- Increases inlet pressure which keeps debris moving instead of recirculating
- E-liminator groove disrupts the accumulation of fibrous debris.

DLFU selection chart

1	50DLFU61.5 2HP	34	100DLFU611 15HP
2	80DLMFU61.5 2HP	35	100DLFU615 20HP
3	80DLMFU62.2 3HP	36	100DLFU618 25HP
4	80DLMFU63.7 5HP	37	100DLFU622 30HP
5	80DLMFU65.5 7½HP	38	150DLFU630 40HP
6	80DLMFU67.5 10HP	39	150DLFU637 50HP
7	80DLCMFU611 15HP	40	150DLFU645 60HP
8	100DLFU61.5 2HP	41	150DLFU67.5 10HP
9	80DLFU61.5 2HP	42	150DLFU611 15HP
10	100DLMFU61.5 2HP	43	150DLFU615 20HP
11	80DLFU62.2 3HP	44	150DLFU618 25HP
12	100DLMFU62.2 3HP	45	150DLFU622 30HP
13	80DLFU63.7 5HP	46	200DLFU630 40HP
14	100DLMFU63.7 5HP	47	200DLFU637 50HP
15	80DLFU65.5 7½HP	48	200DLFU645 60HP
16	100DLMFU65.5 7½HP	49	200DLFU67.5 10HP
17	80DLFU67.5 10HP	50	200DLFU611 15HP
18	100DLMFU67.5 10HP	51	200DLFU615 20HP
19	80DLFU611 15HP	52	200DLFU618 25HP
20	100DLMFU611 15HP	53	200DLFU622 30HP
21	80DLFU615 20HP	54	250DLFU611 15HP
22	100DLMFU615 20HP	55	250DLBFU615 20HP
23	80DLFU618 25HP	56	250DLFU615 20HP
24	100DLMFU618 25HP	57	250DLFU618 25HP
25	80DLFU622 30HP	58	250DLFU622 30HP
26	100DLMFU622 30HP	59	250DLFU630 40HP
27	100DLFU630 40HP	60	250DLFU637 50HP
28	100DLFU637 50HP	61	250DLFU645 60HP
29	100DLFU645 60HP	62	300DLFU618 25HP
30	100DLFU62.2 3HP	63	300DLFU622 30HP
31	100DLFU63.7 5HP	64	300DLFU630 40HP
32	100DLFU65.5 7½HP	65	300DLFU637 50HP
33	100DLFU67.5 10HP	66	300DLFU645 60HP

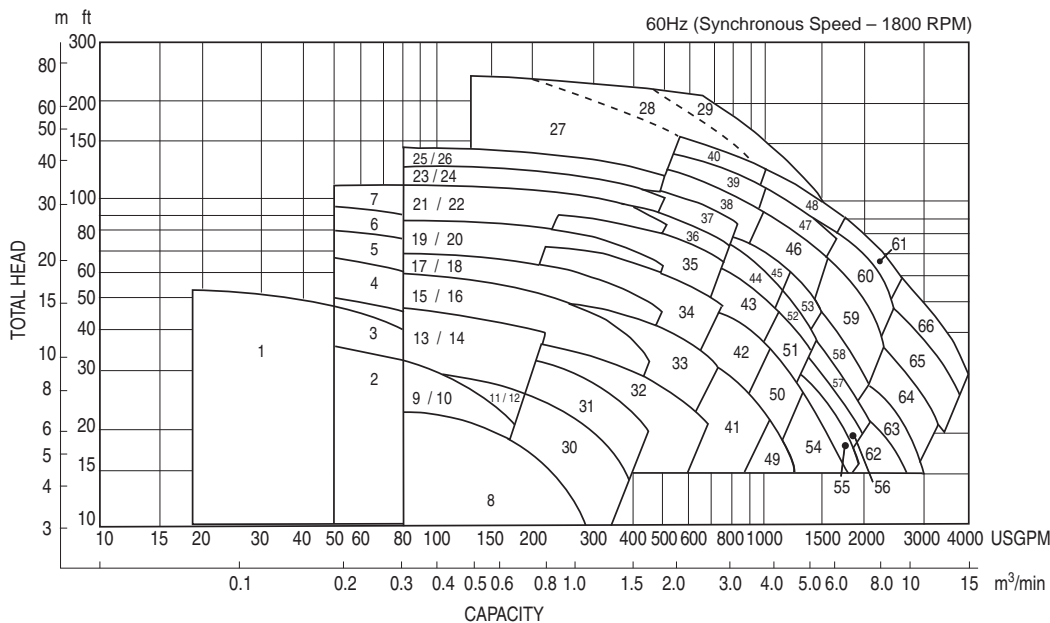

Please note: Overlap in coverage is designated by the two numbers; for example "9 / 10". Refer to the legend left for the specific model numbers.

Model DDLFU



Standard Specifications

Design	Discharge	4"×3", 6"×4", 8"×6", 8"×8", 10"×10", 12"×12"
	Horsepower	15 to 60HP
	Capacity	80 to 4000 GPM
	Total head	20 to 243 feet
	Max.Liquid temp.	104°F/40°C
Speed	1800 RPM	
Materials	Casing	Cast Iron
	Impeller	Cast Iron
	Shaft	420 Stainless Steel
	Motor Frame	Cast Iron
	Fastener	304 Stainless Steel
Construction	Mechanical Seal	
	Double Mechanical Seal – Tandem Arrangement	
	Material – Upper	Carbon/Ceramic
		<i>Optional:</i> Tungsten Carbide/Tungsten/Carbide
	Material – Lower	Silicon Carbide/Silicon Carbide
		<i>Optional:</i> Tungsten Carbide/Tungsten/Carbide
		Tungsten Carbide/Tungsten Carbide
		(200×150DDLFU and greater, 50 & 60 HP only)
	Impeller Type	Semi-open for 15 to 30HP
		Enclosed for 40 to 60HP
	Bearing	Prelubricated Ball Bearing
	Motor	2-5hp=Class F Insulation, 7.5-60hp=Class H Insulation
	<i>Optional:</i> FM Explosion Proof Class 1, Division 1, Group C, D	
	Three Phase	208/230V, 460V
	Service Factor	1.15
	Motor Protection	Built-in Thermal Detector - Klixon Mechanical Seal Leakage - Float Switch
Submersible Cable		40 ft. standard cable length, Optional 66 ft. Optional _____ ft. (customer specified)

DDLFU selection chart

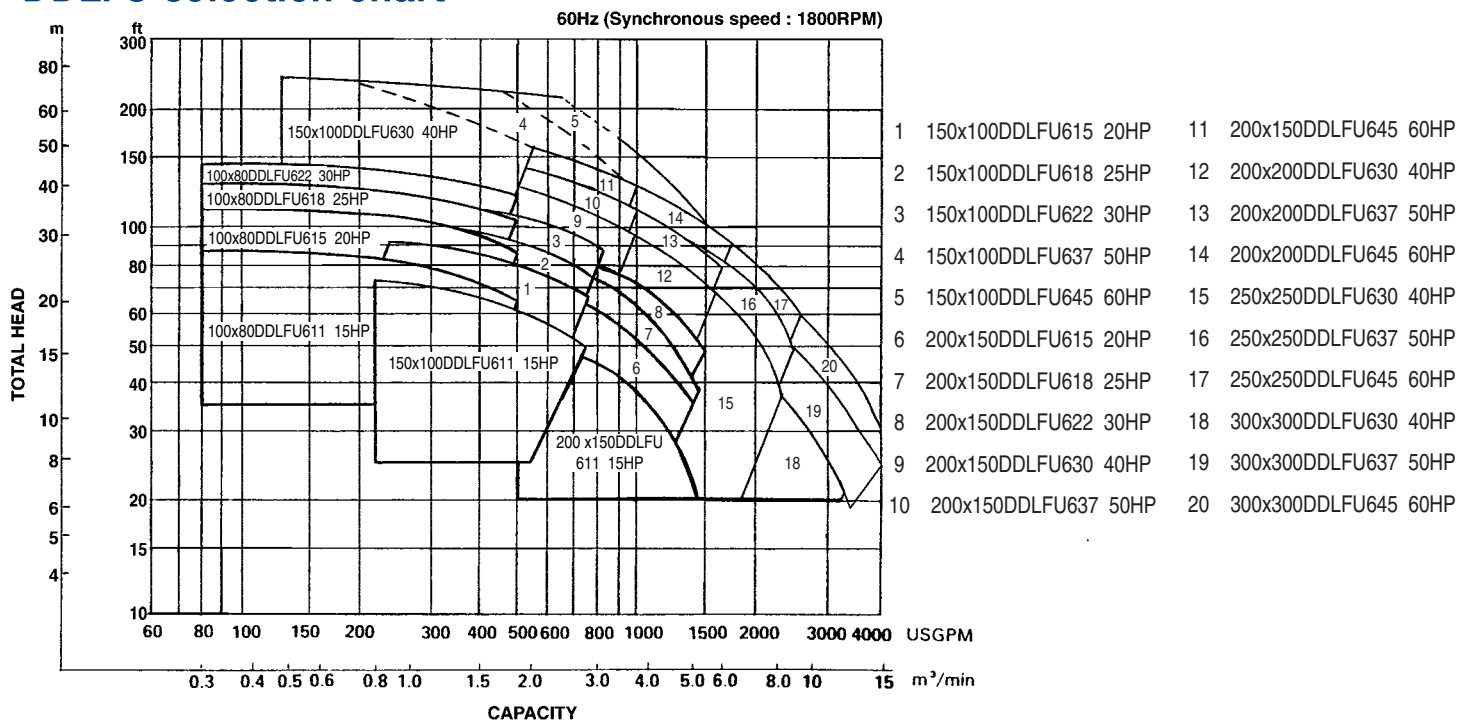

Model DLFU, DLKFU, DDLFU

Features

- **Watertight cable entry system** prevents capillary action and protects against moisture; reduces maintenance costs
- **Heavy duty, high efficiency, air filled** motor dissipates heat easily; thermal protection in each phase of windings protects; operates cooler with higher efficiencies; longer service life with lower operating costs
- **Self cooling jacket** (Model DDLFU) eliminates the need for external pumping devices or special heat transfer fluids; offers simplicity and high reliability by effectively dissipating heat in dry pit applications only
- **Single and double row thrust bearings** carries thrust loads with L-10 life of 60,000 hours; ensures long, dependable operation and lowers maintenance costs
- **Mechanically actuated float switch** provides early warning of mechanical seal failure; avoids costly motor repairs
- **Double mechanical seals – silicon carbide lower seals, carbon/ceramic upper –** hard faced upper and lower seals operate in an oil bath; providing longer service life and lower maintenance costs
- **High efficiency impellers** pass large solids with high outputs and reduces power consumption; impellers are optimized for hydraulic coverage; lowers operating costs

Model DLKFU series pumps are designed to tackle clogging challenges with enhanced passage capabilities for handling of fibrous waste. The design features address the most common reasons for clogging caused by fibrous materials: Reduces material caught on the vane tips, increases inlet pressure which keeps debris moving instead of recirculating and E-eliminators groove disrupts the accumulation of fibrous debris

- **Replaceable wear components** maintains working clearances while reducing casing and volute costs

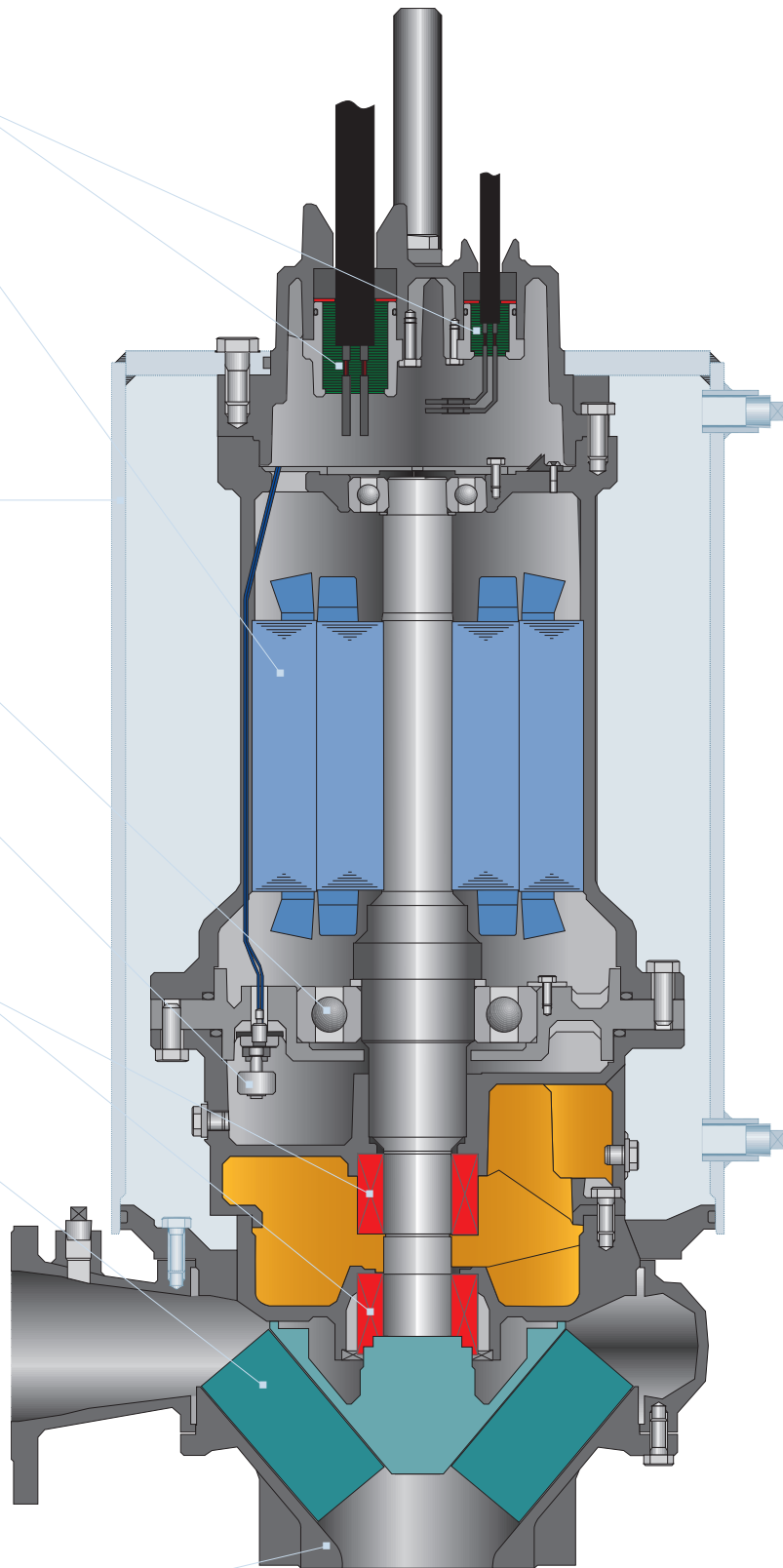

PUMP SUPPLY
INCORPORATED

Model DLFU, DLKFU, DDLFU

Cable Entry System

- Primary seal – grommet (NBR)
- Secondary sealing – O-rings (NBR)
- Epoxy resin – prevents capillary action
- Solid joint butt connector (copper)
- Cable gland (grey cast iron)
- Solid joint butt connector (copper)

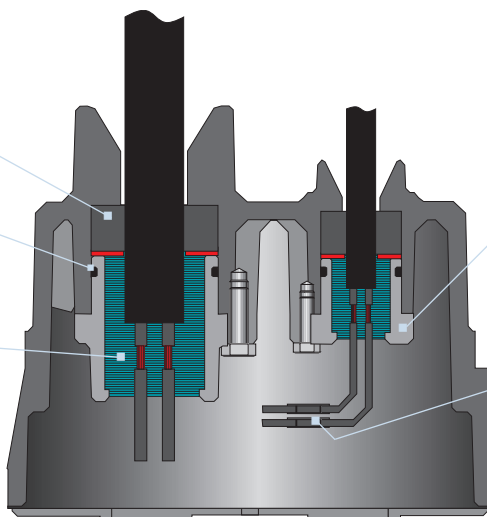

Note: Entry system is the same for both power and control cables.

QDC & Slide Rail System

DDLFU Dry Pit Design

- Motor cooling is provided by internal recirculation of pumpage through water jacket
- Mechanical seal oil chamber

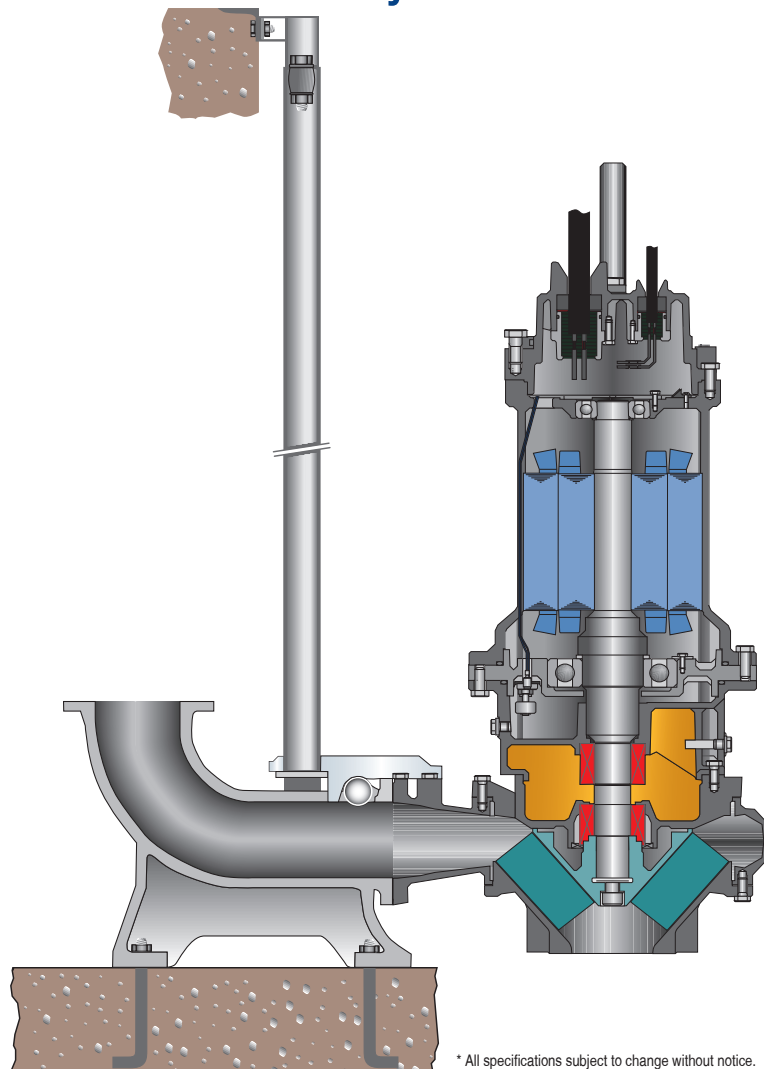
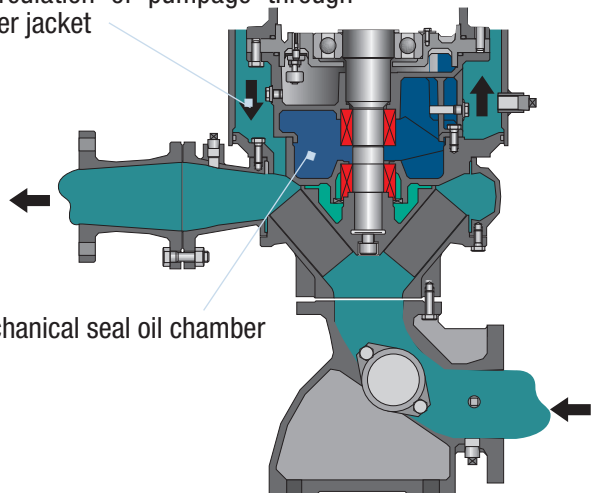

* All specifications subject to change without notice.



EBARA K-Series

An increased frequency of submersible wastewater pumps clogging due to an abundance of improperly disposed materials entering waste streams have plagued pump manufacturers and municipal wastewater facilities over the past decade. Efforts by municipalities to restrict occurrences of such materials entering the system are not always successful.

Ebara DLKF series pumps are designed to tackle these challenges. The Ebara K-series submersible sewage pump maintains the same quality and durability of the Ebara DLF line but with enhanced passage capabilities for handling of fibrous waste.



Adjustable wear plate with an E-eliminitor groove.

Modified vane profiles.

The Ebara K-series design features address the most common reasons for clogging caused by fibrous materials. This design:

- Reduces material caught on the vane tips
- Increases inlet pressure which keeps debris moving instead of recirculating
- E-eliminitor groove disrupts the accumulation of fibrous debris.

When applied as designed, Ebara submersible DLF-series pumps continue to offer superior solids handling for up to three-inch spherical solids. In most applications the standard D-series design can sufficiently handle your pumping requirements, but when the situation calls for something more, choose Ebara K-series.

K-series pumps are available for new equipment sales and as a conversion kit for installed Ebara pumps.



PUMP SUPPLY
INCORPORATED

Field Trials

have shown that the Ebara K-series pumps have dramatically reduced and in some cases eliminated clogging pumps.

South Carolina Municipality:

80DLMF (3 HP), multiple clogging occurrences per week pumps converted to 80DLMKF 9/24/09 – **no clogs as of 9/2/2010**

South Carolina Municipality:

80DLCMF (10 HP), two clogging occurrences per week pumps converted to 80DLCMKF 7/23/09 – **no clogs as of 9/2/2010**

South Carolina Municipality:

80DLMF (7 1/2 HP) multiple clogging occurrences per week, pumps converted to 80DLMKF 11/17/09 – **no clogs as of 9/2/2010**

Ohio Municipality:

100DLMF (15HP) , daily clogging occurrences upgraded to 100DLMKF 10/23/09 – **no clogs as of 9/2/2010**

Iowa Municipality:

100DLMF (10HP), multiple clogging occurrences per week, upgraded to 100DLMKF 11/12/09 – **no clogs as of 9/2/2010**

Florida Municipality:

150DLFU618 (25 HP) 11/5/09 two clogging occurrences per week, upgraded to 150DLKFU618 – **no clogs as of 9/2/2010**



EBARA Pumps Americas Corporation