



EBARA

Ahead  *Beyond*

Model DKEU/DKEXU

Submersible Pump with Anti-Clog Technology



Model DKEU/DKEXU

Features

- Improved efficiency & Flow and Head
- Heavy-duty, premium IE3 efficiency
 - motor operates cooler
 - 20 starts per hour
 - higher efficiency reduces operating costs
 - FM/FMC Explosion Proof Available
- Internal Cooling System (ICS)
 - SS Cooling Jacket
 - Standard for 7.5 hp - 30 hp
 - Optional for 2 hp - 5 hp
- Backswept Impeller works with a guide pin and suction cover groove for Anti-clog performance
- Double mechanical seals - operate in a glycol solution (ICS motors) or an oil bath (non-ICS motors) for longer service life and lower maintenance costs
- Single Multi-conductor cable for power & control
- Watertight cable entry system
- Stainless steel shaft
- Minimum 50,000 hours life with single and double row thrust bearings
- Oversized stainless steel lifting bail
- Easy replaceable wear components
- Easier maintenance, service, and adjustment
- Optional detachable casing legs

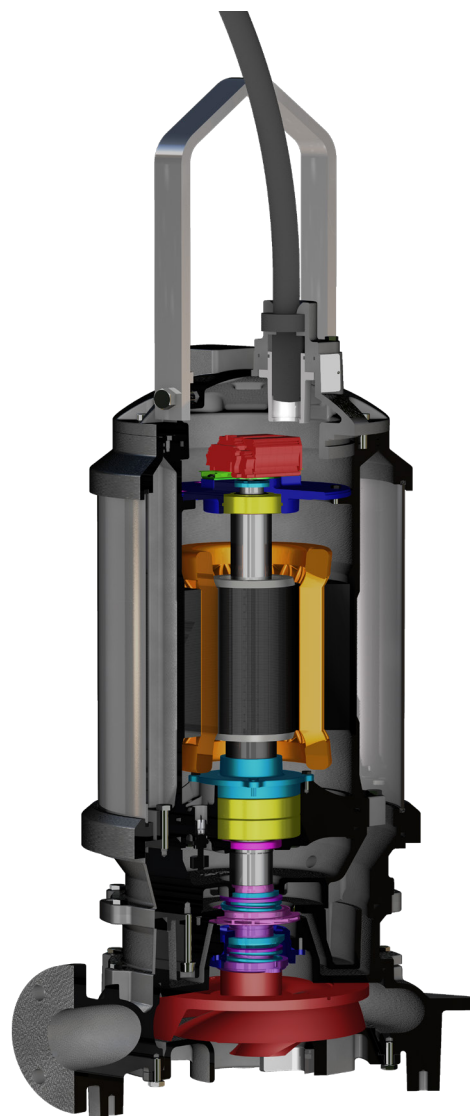

Specifications

- Discharge Size: 2" to 10"
- ANSI Flanges
- Power Range: 2 to 30 hp
- Capacity: 20 to 2800 gpm
- Head: 7 to 185 feet
- Max. liquid temperature: 104°F (40°C)
- FM/FMc Explosion Proof available

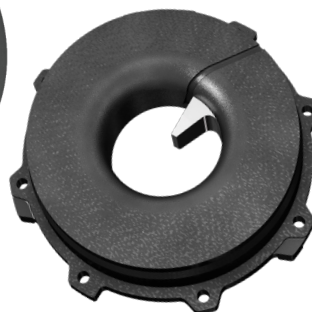
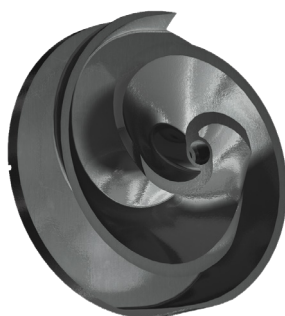

Detailed performance and technical data available
at www.pumpsebara.com/product/dkeu-dkexu/



Model DKEU/DKEXU

Standard Specifications

Construction and Materials Specifications			
Power	2hp - 5hp	7.5hp - 30hp	40hp - 60hp
Discharge	2", 3", 4"	3", 4", 6", 8", 10"	4", 6", 8", 10"
Application	Submersible (max 65ft)		
Installation	QDC or Stand Alone		
Flange	ANSI/Class 150		
Liquid Type	Wastewater and Sewage including fibrous materials		
Liquid Temp	32F-104F (0-40C)		
Motor Class	IE3 60Hz, Air Filled, 3-Phase, 4-Pole, H-Insulation		
Voltage	208V, 230/460V (Dual), 575V	460V, 575V	
Starting Method	DOL / Inverter Duty Rated		
Protection Class	IP68		
Explosion Proof	FM, FMC Class 1 Div. 1: Grp C&D / Temp Class: T3C		
Thermal Prot.	Built in Thermal Detector		
Leak Detection	Float Type Switch		
Cable	50ft - Single Cable w/ Power & Control together		
ICS System	Optional	Standard	
ICS Coolant	PG 50% Solution (-10C-100C)		
Casing/Volute	ASTM Class 35 Cast Iron	Ductile Cast Iron	
Impeller	ASTM Class 35 Cast Iron		
Motor Frame	ASTM Class 35 Cast Iron		
Cooling Jacket	304 Stainless Steel		
Shaft	403 Stainless Steel		
Mechanical Seal	Lower Seal-Liquid Side: SiC/SiC/NBR Upper Seal-Motor Side: Ceramic/Carbon/NBR		

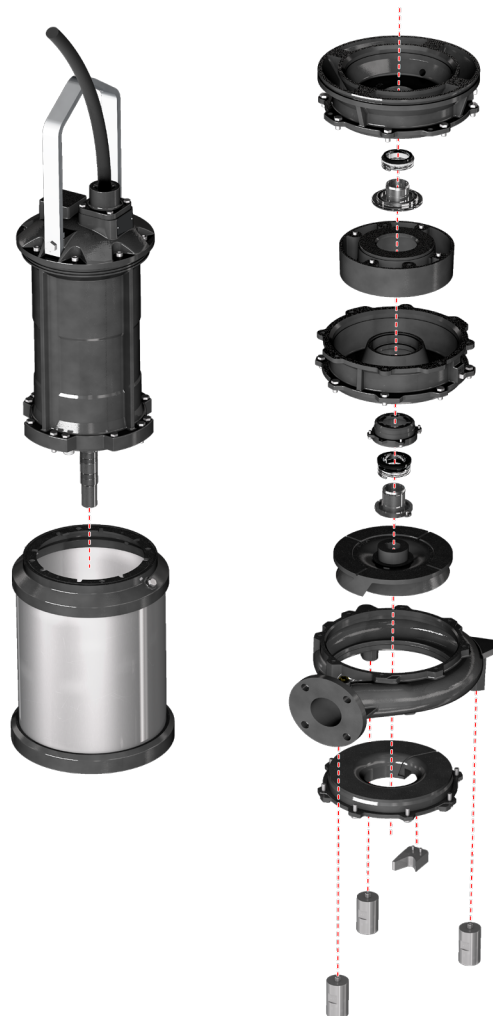

Performance Range

Three Phase 60Hz

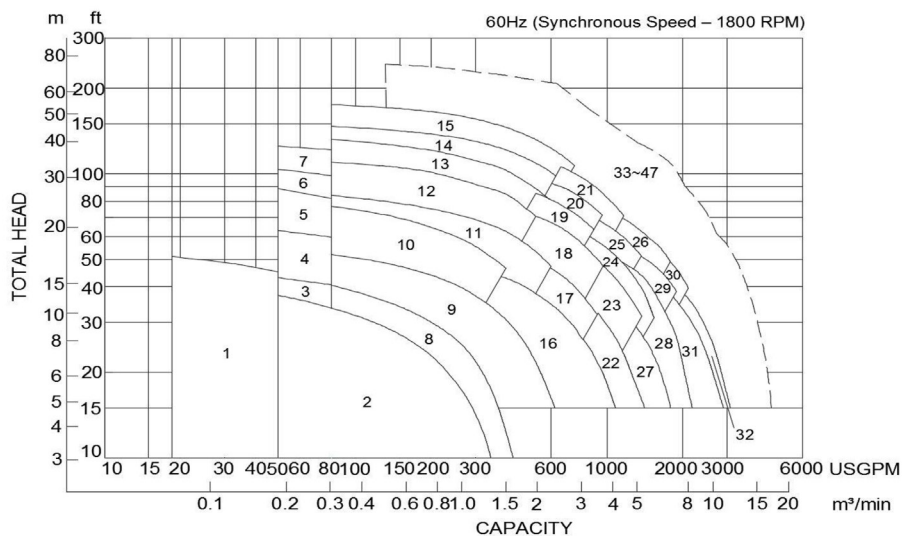

- | | |
|---------------------|--------------------|
| 1 50DKE(X)U461.5 | 17 100DKE(X)U467.5 |
| 2 80DKE(X)U461.5 | 18 100DKE(X)U4611 |
| 3 80DKE(X)U462.2 | 19 100DKE(X)U4615 |
| 4 80DKE(X)U463.7 | 20 100DKE(X)U4618 |
| 5 80DKE(X)U465.5 | 21 100DKE(X)U4622 |
| 6 80DKE(X)U467.5 | 22 150DKE(X)U467.5 |
| 7 80DKE(X)U4611 | 23 150DKE(X)U4611 |
| 8 100DKE(X)U462.2 | 24 150DKE(X)U4615 |
| 9 100DKE(X)U463.7 | 25 150DKE(X)U4618 |
| 10 100DKEB(X)U465.5 | 26 150DKE(X)U4622 |
| 11 100DKEB(X)U467.5 | 27 200DKE(X)U4611 |
| 12 100DKEB(X)U4611 | 28 200DKE(X)U4615 |
| 13 100DKEB(X)U4615 | 29 200DKE(X)U4618 |
| 14 100DKEB(X)U4618 | 30 200DKE(X)U4622 |
| 15 100DKEB(X)U4622 | 31 250DKE(X)U4618 |
| 16 100DKE(X)U465.5 | 32 250DKE(X)U4622 |





Applications

Municipal Wastewater • Sewage • Lift Stations • Packaged Pump Systems
 Storm Water and Flood Control • Industrial Wastewater

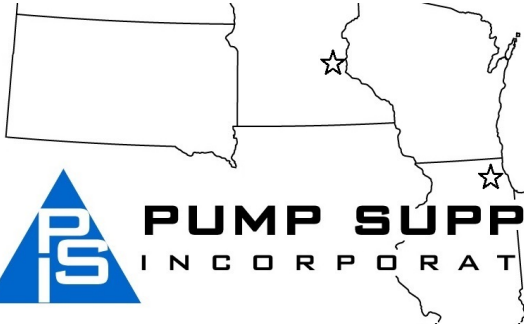
<p><u>Illinois Location:</u> (847) 841-7867 860 Church Rd Elgin, IL 60120</p> <p><u>Minnesota Location:</u> (651) 758-7867 330 Mill Bay South Suite : Afton, MN 55001</p> <p>PumpSupplyInc.com</p>	 <p>PS PUMP SUPPLY INCORPORATED</p>
---	--