

Technical Information

Contents

Section	Page
Material Specification	2-290
Impeller Design Data	2-291
Motor Protection DGUII, DLU, DVU Models	2-295
Thermal Protection DGFU, DLFU, DVFU, DDLFU Models	2-296
Leakage Detector DGFU, DLFU, DVFU, DDLFU Models	2-297
Cable Entry DGUII, DLU, DVU Models	2-298
Cable Entry DGFU, DLFU, DVFU, DDLFU Models	2-299
Paint Specifications	2-300
Mechanical Seal & Ball Bearing Data	2-301
Mechanical Seal Sectional DWG A-20, A-25, A-30	2-302
Mechanical Seal Sectional DWG A-40, A-45	2-303
Mechanical Seal Sectional DWG A-50	2-304
Mechanical Seal Sectional DWG A-60	2-305
Submergence	2-306
Capacitor Specification	2-307
QDC Lifting Chain	2-308
General Information	2-309



Technical Information

Project:

Model:

Chk'd:

Date:

Material Comparison Table

MATERIALS	JIS CODE	ASTM, AISI CODE
Cast Iron	G5501, FC20	ASTM A-48 Class 30
420 Stainless	G4303, SUS429J1	AISI 420
304 Stainless Steel	G4303, SUS304	AISI 304
Steel	G3101, SS41	ASTM A283 Grade D
Brass	H3201, BSP3	ASTM B36 No. 272



Technical Information

Project: _____ Model: _____ Chk'd: _____ Date: _____

Impeller Data

MODEL	TYPE	DESIGN	# VANES	BACK P.O. VANES
50DLU6.75	semi-open	radial	single	yes
50DLU61.5	semi-open	radial	single	yes
80DLU61.5	semi-open	radial	single	yes
80DLMU61.5	semi-open	radial	single	yes
80DLU62.2	semi-open	radial	2	yes
80DLMU62.2	semi-open	radial	single	yes
80DLU63.7	semi-open	radial	2	yes
80DLMU63.7	semi-open	radial	2	yes
100DLU61.5	semi-open	radial	2	no
100DLU62.2	semi-open	radial	2	no
100DLU63.7	semi-open	radial	2	no
50DVU6.75	semi-open	radial-recessed	8	yes
50DVU61.5	semi-open	radial-recessed	8	yes
50DVU62.2	semi-open	radial-recessed	8	yes
80DVU61.5	semi-open	radial-recessed	8	yes
80DVCU62.2	semi-open	radial-recessed	8	yes
80DVBU62.2	semi-open	radial-recessed	8	yes
80DVBU63.7	semi-open	radial-recessed	8	yes
80DVCU63.7	semi-open	radial-recessed	8	yes
100DVU63.7	semi-open	radial-recessed	8	yes
32DGUII61.5	semi-open	radial-recessed	10	yes
32DGFU61.5	semi-open	radial-recessed	10	yes
50DGFU62.2	semi-open	radial-recessed	10	yes
50DGFU63.7	semi-open	radial-recessed	10	yes
50DLFU61.5	semi-open	radial	single	yes
80DLFU61.5	semi-open	radial	single	yes
80DLMFU61.5	semi-open	radial	single	yes
80DLFU62.2	semi-open	radial	2	yes
80DLFMU62.2	semi-open	radial	single	yes
80DLFU63.7	semi-open	radial	2	yes
80DLMFU63.7	semi-open	radial	2	yes
80DLFU65.5	semi-open	mixed flow	2	yes
80DLMFU65.5	semi-open	mixed flow	2	yes
80DLFU67.5	semi-open	mixed flow	2	yes
80DLCMFU 67.5	semi-open	mixed flow	2	yes
80DLF611	semi-open	mixed flow	2	yes
80DLCMFU611	semi-open	mixed flow	2	yes



Technical Information

Project: _____ Model: _____ Chk'd: _____ Date: _____

Impeller Data

MODEL	TYPE	DESIGN	# VANES	BACK P.O. VANES
80DLFU615	semi-open	mixed flow	2	yes
80DLFU618	semi-open	mixed flow	2	yes
80DLFU622	semi-open	mixed flow	2	yes
100DLFU61.5	semi-open	radial	2	no
100DLFU62.2	semi-open	radial	2	no
100DLFU63.7	semi-open	radial	2	no
100DLFU65.5	semi-open	mixed flow	2	yes
100DLMFU65.5	semi-open	mixed flow	2	yes
100DLFU67.5	semi-open	mixed flow	2	yes
100DLFU611	semi-open	mixed flow	2	yes
100DLFU615	semi-open	mixed flow	2	yes
100DLFU618	semi-open	mixed flow	2	yes
100DLFU622	semi-open	mixed flow	2	yes
100DLFU630	enclosed	radial	2	yes
100DLFU637	enclosed	radial	2	yes
100DLFU645	enclosed	radial	2	yes
150DLFU67.5	semi-open	mixed flow	2	yes
150DLFU611	semi-open	mixed flow	2	yes
150DLFU615	semi-open	mixed flow	2	yes
150DLFU618	semi-open	mixed flow	2	yes
150DLFU622	semi-open	mixed flow	2	yes
150DLFU630	enclosed	mixed flow	2	yes
150DLFU637	enclosed	mixed flow	2	yes
150DLFU645	enclosed	mixed flow	2	yes
200DLFU67.5	semi-open	mixed flow	2	yes
200DLFU611	semi-open	mixed flow	2	yes
200DLFU615	semi-open	mixed flow	2	yes
200DLFU618	semi-open	mixed flow	2	yes
200DLFU622	semi-open	mixed flow	2	yes
200DLFU630	enclosed	mixed flow	2	yes
200DLFU637	enclosed	mixed flow	2	yes
200DLFU645	enclosed	mixed flow	2	yes
250DLFU611	semi-open	mixed flow	2	yes
250DLFU615	semi-open	mixed flow	2	yes
250DLFU618	semi-open	mixed flow	2	yes
250DLFU622	semi-open	mixed flow	2	yes
250DLFU630	enclosed	mixed flow	2	yes
250DLFU637	enclosed	mixed flow	2	yes
250DLFU645	enclosed	mixed flow	2	yes
300DLFU618	semi-open	mixed flow	2	yes
300DLFU622	semi-open	mixed flow	2	yes



Technical Information

Project: _____ Model: _____ Chk'd: _____ Date: _____

Impeller Data

MODEL	TYPE	DESIGN	# VANES	BACK P.O. VANES
300DLFU630	enclosed	mixed flow	2	yes
300DLFU637	enclosed	mixed flow	2	yes
300DLFU645	enclosed	mixed flow	2	yes
50DVF61.5	semi-open	radial-recessed	8	yes
50DVF62.2	semi-open	radial-recessed	8	yes
80DVF61.5	semi-open	radial-recessed	8	yes
80DVBF62.2	semi-open	radial-recessed	8	yes
80DVCF62.2	semi-open	radial-recessed	8	yes
80DVBF63.7	semi-open	radial-recessed	8	yes
80DVCF63.7	semi-open	radial-recessed	8	yes
80DVF65.5	semi-open	radial-recessed	8	yes
80DVF67.5	semi-open	radial-recessed	8	yes
80DVBF611	semi-open	radial-recessed	8	yes
80DVCF611	semi-open	radial-recessed	8	yes
80DVCF615	semi-open	radial-recessed	8	yes
80DVCF618	semi-open	radial-recessed	8	yes
80DVCF622	semi-open	radial-recessed	8	yes
100DVF63.7	semi-open	radial-recessed	8	yes
100DVF65.5	semi-open	radial-recessed	8	yes
100DVF67.5	semi-open	radial-recessed	8	yes
100DVBF611	semi-open	radial-recessed	8	yes
100DVCF611	semi-open	radial-recessed	8	yes
100DVDF611	semi-open	radial-recessed	8	yes
100DVCF615	semi-open	radial-recessed	8	yes
100DVDF615	semi-open	radial-recessed	8	yes
100DVDF618	semi-open	radial-recessed	8	yes
100DVDF622	semi-open	radial-recessed	8	yes
150DVBF611	semi-open	radial-recessed	8	yes
150DVBF615	semi-open	radial-recessed	8	yes
150DVBF618	semi-open	radial-recessed	8	yes
150DVCF618	semi-open	radial-recessed	8	yes
150DVBF622	semi-open	radial-recessed	8	yes
150DVCF622	semi-open	radial-recessed	8	yes
100x80DDLUFU611	semi-open	mixed flow	2	yes
100x80DDLUFU615	semi-open	mixed flow	2	yes
100x80DDLUFU618	semi-open	mixed flow	2	yes
100x80DDLUFU622	semi-open	mixed flow	2	yes
150x100DDLUFU611	semi-open	mixed flow	2	yes



Technical Information

Project: _____ Model: _____ Chk'd: _____ Date: _____

Impeller Data

MODEL	TYPE	DESIGN	# VANES	BACK P.O. VANES
150×100DDLDFU615	semi-open	mixed flow	2	yes
150×100DDLDFU618	semi-open	mixed flow	2	yes
150×100DDLDFU622	semi-open	mixed flow	2	yes
150×100DDLDFU630	enclosed	radial	2	yes
150×100DDLDFU637	enclosed	radial	2	yes
150×100DDLDFU645	enclosed	radial	2	yes
200×150DDLDFU611	semi-open	mixed flow	2	yes
200×150DDLDFU615	semi-open	mixed flow	2	yes
200×150DDLDFU618	semi-open	mixed flow	2	yes
200×150DDLDFU622	semi-open	mixed flow	2	yes
200×150DDLDFU630	enclosed	mixed flow	2	yes
200×150DDLDFU637	enclosed	mixed flow	2	yes
200×150DDLDFU645	enclosed	mixed flow	2	yes
200×150DDLDFU630	enclosed	mixed flow	2	yes
200×150DDLDFU637	enclosed	mixed flow	2	yes
200×150DDLDFU645	enclosed	mixed flow	2	yes
200×200DDLDFU630	enclosed	mixed flow	2	yes
200×200DDLDFU637	enclosed	mixed flow	2	yes
200×200DDLDFU645	enclosed	mixed flow	2	yes
250×250DDLDFU630	enclosed	mixed flow	2	yes
250×250DDLDFU637	enclosed	mixed flow	2	yes
250×250DDLDFU645	enclosed	mixed flow	2	yes
300×300DDLDFU630	enclosed	mixed flow	2	yes
300×300DDLDFU637	enclosed	mixed flow	2	yes
300×300DDLDFU645	enclosed	mixed flow	2	yes



Technical Information

Project:

Model:

Chk'd:

Date:

Motor Protection (Auto-Cut)

1. MODELS DLU, DVU, DGUII

2. CONSTRUCTION AND PRINCIPLES OF OPERATION

There are two different types of Auto-Cuts. One is a single pole model that is used for single phase motors and the other is a three pole model that is used for three phase motors. Figure 1 below illustrates the construction and operation of the three phase model.

Composition: 3 sets of contacts, 1 Snap-Acting Disk, 3 Heaters, 3 Terminals and 1 Calibration bolt and nut. The above parts are encased in a Bakelite housing.

FIGURE 1

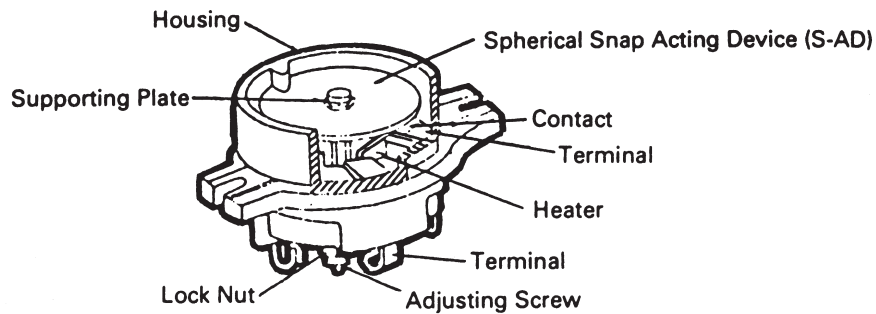

The Auto-Cut is installed directly over the winding of the motor, where it not only senses overheating of the winding but also excess amperage draw by each of the three windings.

Figure 2 shows the Auto-Cut in its normal operating condition (Contacts closed). When actuating temperature is reached, the Snap-Acting Disk snaps open to interrupt the circuits as shown in figure 3.

When the motor temperature cools down to the safe operating temperature, the Snap-Acting Disk resets automatically to the original position as shown in figure 2, and the motor restarts.

FIGURE 2

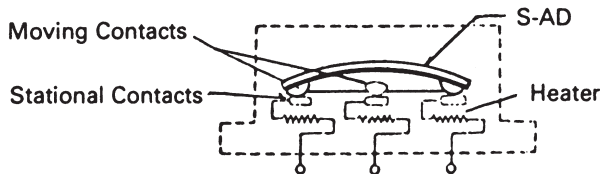
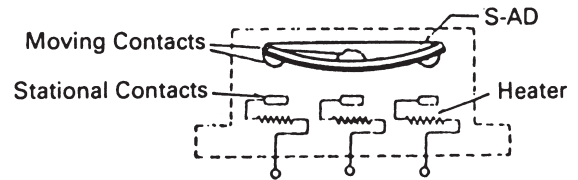

FIGURE 3



3. PROVIDES PROTECTION FROM THE FOLLOWING:

- Single Phasing
- Low Voltage
- Phase Imbalance
- Locked Rotor
- Run Dry

All of the above conditions will cause the motor protector to actuate.

Technical Information

Project: _____

Model: _____

Chk'd: _____

Date: _____

Thermal Protection

The motor shall be equipped with a protector such as automatic cut-off device and thermal protector. The motors described below shall incorporate Miniature Thermal Protectors (MTP) which are embedded in the windings.

When temperature of the winding raises and reaches the MTP acting point, the motor protection circuit is activated to protect motor from over heat.

1. Applicable model

Model: DGFU, DLFU, DVFU, DDLFU

2. MTP Specifications:

Model	KLIXON 9700K-66-215
Type of Contact	b (Normally-Closed contact Acting-open)
Acting Temperature	140±5 C (284±9°F)
Re-setting Temperature	85±10°C (185±18°F)
Capacity of Contact	

Voltage (V)	DC 24	AC 115	AC 230	AC 460
Amperage (A)	18	18	13	5.5

3. Installation:

MTP shall be embedded in the stator windings as shown at right—

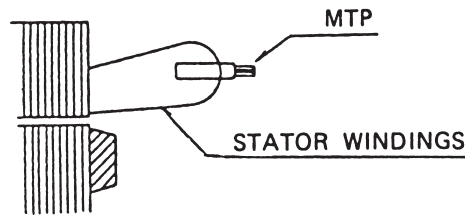

4. Construction:

Construction of the MTP is as shown below:

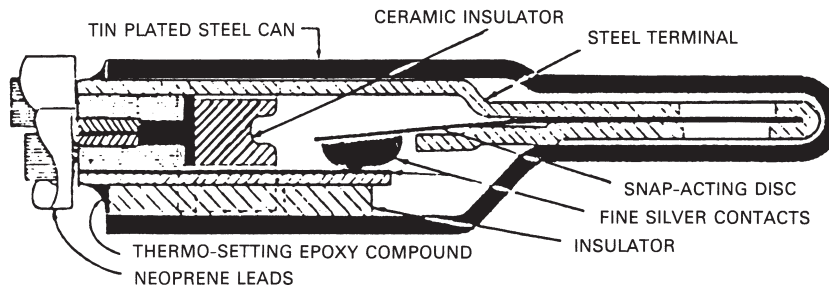

Technical Information

Project: _____ Model: _____ Chk'd: _____ Date: _____

Details of Leakage Detector

1. Applicable model

Model: DGFU, DLFU, DVFU, DDLFU

2. Construction:

Each switch has a magnet-containing float which senses the liquid level and magnetically actuates a dry reed switch encapsulated within a stem. The switch opens on rise of liquid.

3. Specifications

- Apply to 2 to 30HP

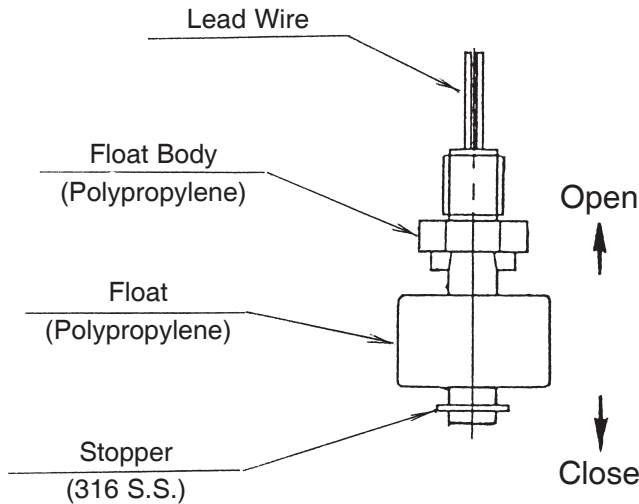

Breaking Capacity : AC50VA, DC50W

Max. Breaking Current : AC0.5A, DC0.5A

Max. Operating Voltage : AC300V, DC300V

- Apply to 40 to 60HP

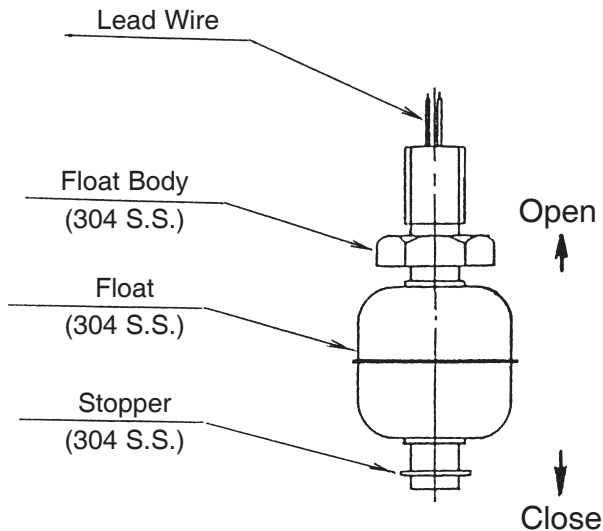

Breaking Capacity : AC12VA, DC10W

Max. Breaking Current : AC0.6A, DC0.5A

Max. Operating Voltage : AC200V, DC200V

Technical Information

Project: _____ Model: _____ Chk'd: _____ Date: _____

**Details of Cable Entry (1 of 2)
Applicable to Models DGUII, DLU, DVU**

①	Water cannot leak into motor even if the cable is cut or damaged because cable leads are soldered and then isolated by rubber sealing, thus preventing any capillary action past that point.
②	Thick moulded shoulders bolted to motor dome provide exceptional strength and form a strong compression seal.
③	Cable resists bending forces by increased cable diameter.
④	A Strain Relief Chain or Strain Relief Gland protects cable entry from pulling.

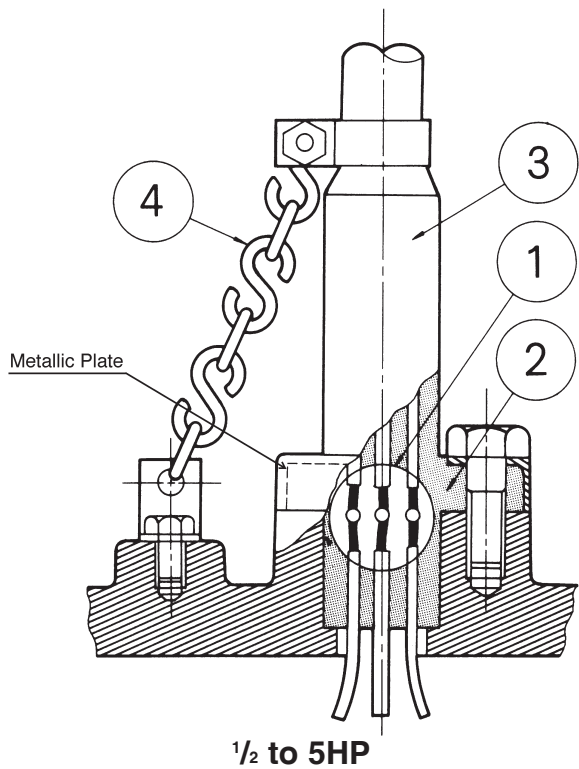

Technical Information

Project:

Model:

Chk'd:

Date:

Details of Cable Entry (2 of 2)

Applicable to Models DLFU, DVFU, DDLFU, DGFU

Based on their first years of experience, EBARA now provides the most dependable cable entry construction of any submersible pump. Its features are as follows:

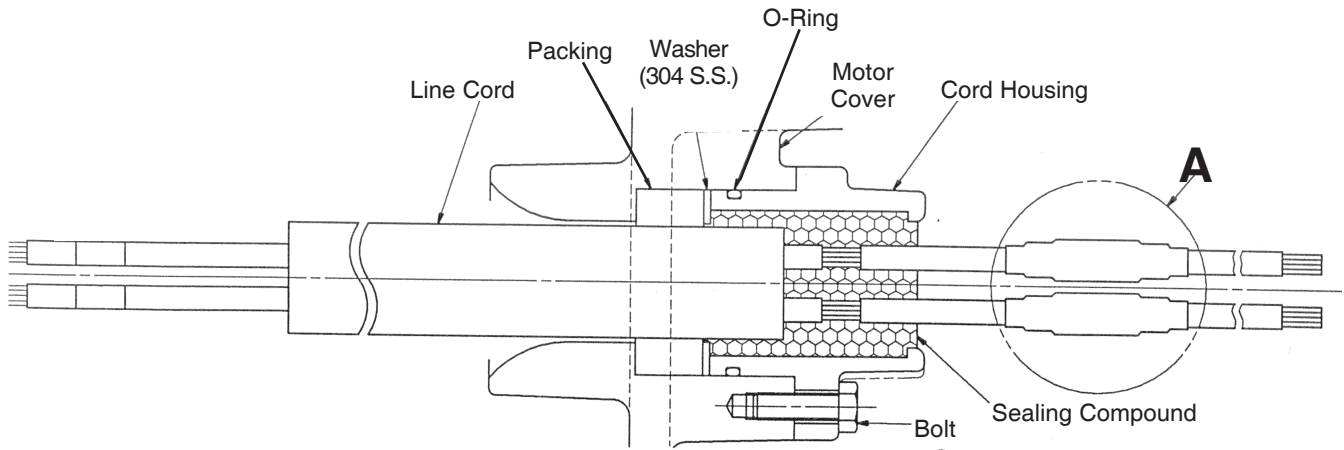

DETAIL "A"

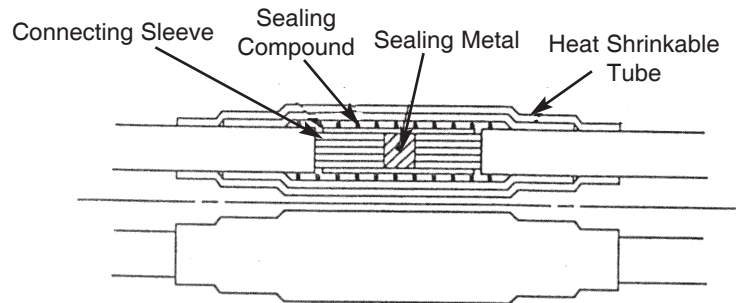

EBARA Submersible Pumps **DLU, DVU, DGUII, DGFU, DLFU, DVFU, DDLFU**

Technical Information

Project: _____ Model: _____ Chk'd: _____ Date: _____

Shop Painting Standards

1. Scope

This specification covers the methods for painting the following EBARA PUMPS in the shop.

EBARA Models: **DGUII, DLU, DVU, DGFU, DLFU, DVFU, DDLFU**

2. Surface Preparation

All surfaces to be painted shall be cleaned of oil, grease or other similar materials with solvent, and then shall be brushed and air blasted to remove rust or scale.

Prior to above preparation, mill scale, rust scale, chips and other foreign materials shall be removed in accordance with painting schedule.

3. Coating Procedure

Detailed coating procedures are as shown in each paint schedule.

Service	Painting Schedule			
	Surface Preparation		SPPC-VISI-SP-3-63	
External Surface	Coats	Type of Paint	Brand Name	Maker
	1st	Zinc-chromate primer	ZT-PRIMER	TAIYO PAINT CO., LTD.
	2nd	Coal Tar Epoxy	Hi-Build Tneme-Tar 46-413	TNEMEC CO., INC.

Final color: Black

Service	Painting Schedule			
	Surface Preparation		SPPC-VISI-SP-3-63	
Internal Surface	Coats	Type of Paint	Brand Name	Maker
	1st	Zinc-chromate primer	ZT-PRIMER	TAIYO PAINT CO., LTD.



EBARA Submersible Pumps DLU, DVU, DGUII, DGFU, DLFU, DVFU, DDLFU

Technical Information

Project: _____ Model: _____ Chk'd: _____ Date: _____

Mechanical Seal and Ball Bearing Data

MODEL	OUTPUT		MECHANICAL SEAL TYPE	LUBRICATING OIL CAPACITY		LUBRICATING OIL NAME	BALL BEARING	
	HP	kW		OZS	CC		BOTTOM	TOP
			DGUII			2		
DGFU	3	2.2	A-30	43	1200	6308ZZDR	6304ZZ	
	5	3.7	A-30	43	1200	6308ZZDR	6304ZZ	

MODEL	OUTPUT		MECHANICAL SEAL TYPE	LUBRICATING OIL CAPACITY		LUBRICATING OIL NAME	BALL BEARING	
	HP	kW		OZS	CC		BOTTOM	TOP
			DLU DLMU DVU DLFU DLMFU DVFU DDLFU			1		
2	1.5	A-25		40	930	6306ZZ	6204ZZ	
3	2.2	A-30		50	1380	6307ZZ	6205ZZ	
5	3.7	A-30		50	1380	6308ZZ	6205ZZ	
7½	5.5	A-40		90	2500	6309ZZ	6306ZZ	
10	7.5	A-40		90	2500	6309ZZ	6306ZZ	
15	11	A-40		120	3500	6313ZZ	6308ZZ	
20	15	A-45		210	6200	6315ZZ	6308ZZ	
25	18.5	A-45		210	6200	6315ZZ	6309ZZ	
30	22	A-45		210	6200	6315ZZ	6309ZZ	
40	30	A-45		220	6500	5314ZZDR	6309ZZ	
50	37	A-50		240	7000	5315ZZDR	6310ZZ	
†50	37	A-60		240	7000	5315ZZDR	6310ZZ	
60	45	A-50		240	7000	5315ZZDR	6310ZZ	
†60	45	A-60		240	7000	5315ZZDR	6310ZZ	

† Apply to 100DLFU and 150x100DDLFU only



EBARA Submersible Pumps DLU, DVU, DGUII, DGFU, DLFU, DVFU, DDLFU

Technical Information

Project: _____ Model: _____ Chk'd: _____ Date: _____

Mechanical Seal Sectional View

DOUBLE MECHANICAL SEALS with HARD seal face materials are provided on all EBARA "D Series" submersible pumps.

The double mechanical seal in oil chamber provides long life and friction-free sealing of the motor shaft.

Typical construction and materials are as follows:

- TYPE A-20, A-25, A-30
 DGUII, 2HP
 DGFU, 2 to 5HP
 DLU, 1 to 5HP
 DVU, 1 to 5HP
 DLFU, 2 to 5HP
 DVFU, 2 to 5HP

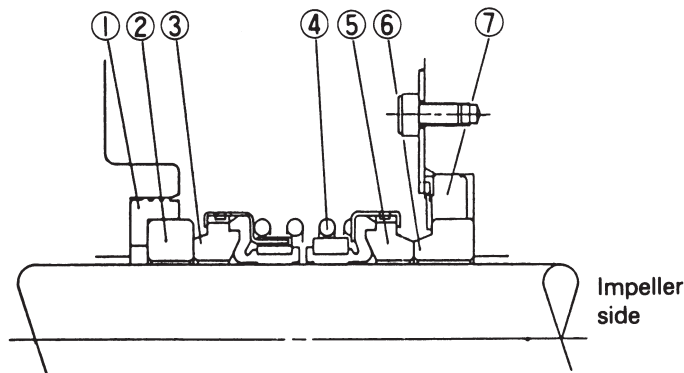

NO.	PART NAME	PART NAME	NO. FOR 1 SET
1	Packing	N.B.R.	1
2	Floating	Ceramic	1
3	Seal Ring	Carbon Graphite	1
4	Spring	304 SS	1
5	Seal Ring	Silicon Carbide	1
6	Floating Ring	Silicon Carbide	1
7	Packing	N.B.R.	1

EBARA Submersible Pumps DLU, DVU, DGUII, DGFU, DLFU, DVFU, DDLFU

Technical Information

Project: _____ Model: _____ Chk'd: _____ Date: _____

Mechanical Seal Sectional View

DOUBLE MECHANICAL SEALS in a tandem arrangement with HARD seal face materials are provided on all EBARA "D-Series" submersible pumps.

The double mechanical seal in oil chamber provides long life and friction-free sealing of the motor shaft.

Typical construction and materials are as follows:

- **TYPE A-40, A-45**
DLFU, 7½ to 40HP
DVFU, 7½ to 30HP
DDLFU, 15 to 40HP

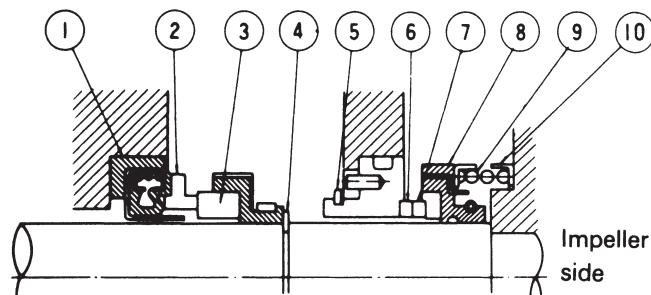

NO.	PART NAME	MATERIALS	NO. FOR 1 SET
1	Packing	N.B.R.	1
2	Seal Ring	Carbon Graphite	1
3	Floating Ring	Ceramic	1
4	Snap Ring	Spring Steel	1
5	Snap Ring	Spring Steel	1
6	Floating Ring	Silicon Carbide	1
7	Seal Ring	Silicon Carbide	1
8	Shock Absorbing Rubber	Fluorine Rubber	1
9	Spring	304SS	1
10	Spring Retainer	304SS	1

Technical Information

Project:

Model:

Chk'd:

Date:

Mechanical Seal Sectional View

DOUBLE MECHANICAL SEALS in a tandem arrangement with HARD seal face materials are provided on all EBARA "D-Series" submersible pumps.

The double mechanical seal in oil chamber provides long life and friction-free sealing of the motor shaft.

Typical construction and materials are as follows:

- **TYPE A-50**
DLFU, 50 to 60HP
DDLFU, 50 to 60HP
Except 100DLFU & 150x100DDLFU

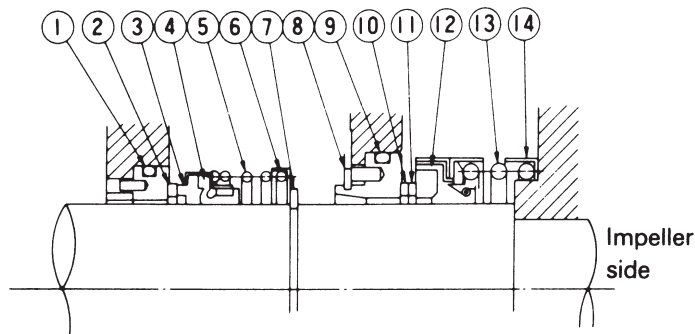

NO.	PART NAME	MATERIALS	NO. FOR 1 SET
1	O-Ring	N.B.R.	1
2	Floating Ring	304SS/Ceramic	1
3	Seal Ring	Carbon Graphite	1
4	Bellows	N.B.R.	1
5	Spring	304SS	1
6	Spring Retainer	304SS	1
7	Snap Ring	Spring Steel	1
8	Snap Ring	Spring Steel	1
9	O-Ring	N.B.R.	1
10	Floating Ring	Tungsten Carbide	1
11	Seal Ring	Tungsten Carbide	1
12	Shock Absorbing Rubber	Fluorine Rubber	1
13	Spring	304SS	1
14	Spring Retainer	304SS	1



Technical Information

Project:

Model:

Chk'd:

Date:

Mechanical Seal Sectional View

DOUBLE MECHANICAL SEALS in a tandem arrangement with HARD seal face materials are provided on all EBARA "D-Series" submersible pumps.

The double mechanical seal in oil chamber provides long life and friction-free sealing of the motor shaft.

Typical construction and materials are as follows:

- **TYPE A-60**
DLFU, 50 to 60HP
DDLFU, 50 to 60HP
100DLFU & 150x100DDLFU ONLY

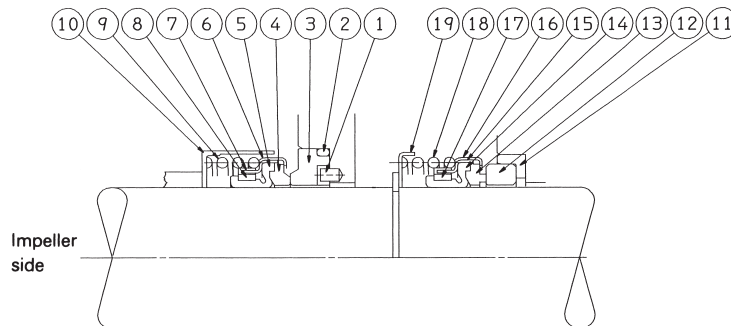

NO.	PART NAME	MATERIALS	NO. FOR 1 SET
1	Parallel Pin	316S.S.	1
2	O-Ring	N.B.R.	1
3	Stationary Ring	Silicon Carbide	1
4	Rotating Ring	Silicon Carbide	1
5	Bellows	N.B.R.	1
6	Case	304SS	1
7	Case	304SS	1
8	Drive Ring	304SS	1
9	Spring	304SS	1
10	Spring Retainer	304SS	1
11	Packing	N.B.R.	1
12	Rotating Ring	Carbon Graphite	1
13	Stationary Ring	Ceramic	1
14	Bellows	N.B.R.	1
15	Case	304SS	1
16	Case	304SS	1
17	Drive Ring	304SS	1
18	Spring	304SS	1
19	Spring Retainer	304SS	1



Technical Information

Project: _____ Model: _____ Chk'd: _____ Date: _____

Maximum Submergence of Pumps

EBARA submersible pumps shall be capable of continuous submergence under water without loss of watertight integrity to the following depths:

- 65 ft.



Technical Information

Project: _____ Model: _____ Chk'd: _____ Date: _____

Start and Operating Capacitor Specification

Model DGUII

Model	Start Capacitor			Operating Capacitor		
	Capacity	Voltage	Temp.	Capacity	Voltage	Temp.
32DGUII61.5S	161~193µF	250VAC	-4~+159°F	25µF	440VAC	-13~+156°F

Model DGFU

Model	Start Capacitor			Operating Capacitor		
	Capacity	Voltage	Temp.	Capacity	Voltage	Temp.
32DGFU61.5S	161~193µF	250VAC	-4~+159°F	25µF	440VAC	-13~+156°F
50DGFU62.2S	270~324µF	250VAC	-4~+159°F	35µF	440VAC	-13~+156°F
50DGFU63.7S	216~259µF	250VAC	-4~+159°F	55µF	440VAC	-13~+156°F

Model DLU/DLMU

Model	Start Capacitor			Operating Capacitor		
	Capacity	Voltage	Temp.	Capacity	Voltage	Temp.
50DLU67.5S	40µF	250VAC	-4~+159°F	20µF	440VAC	-13~+156°F
⁵⁰ / ₈₀ DLU61.5S	100µF	250VAC	-4~+159°F	30µF	440VAC	-13~+156°F
⁸⁰ / ₁₀₀ DLU62.2S	200µF	250VAC	-4~+159°F	35µF	440VAC	-13~+156°F
⁸⁰ / ₁₀₀ DLU63.7S	400µF	250VAC	-4~+159°F	40µF	440VAC	-13~+156°F
80DLMU61.5S	100µF	250VAC	-4~+159°F	30µF	440VAC	-13~+156°F
80DLMU62.2S	200µF	250VAC	-4~+159°F	35µF	440VAC	-13~+156°F
80DLMU63.7S	400µF	250VAC	-4~+159°F	40µF	440VAC	-13~+156°F

Model DVU

Model	Start Capacitor			Operating Capacitor		
	Capacity	Voltage	Temp.	Capacity	Voltage	Temp.
50DVU6.75S	40µF	250VAC	-4~+159°F	20µF	440VAC	-13~+156°F
⁵⁰ / ₈₀ DVU61.5S	100µF	250VAC	-4~+159°F	30µF	440VAC	-13~+156°F
⁵⁰ / ₈₀ DVCU ⁸⁰ / ₁₀₀ DVBU	200µF	250VAC	-4~+159°F	35µF	440VAC	-13~+156°F
⁸⁰ / ₁₀₀ DVCU ⁸⁰ / ₁₀₀ DVBU	400µF	250VAC	-4~+159°F	40µF	440VAC	-13~+156°F

Lifting chain

Project: _____ Model: _____ Chk'd: _____ Date: _____

Lifting Chain

The Ebara lifting chain is high tensile strength galvanized steel or stainless

Model	Size(A)		Material	Max. Load		Weight		B		Length (C)	
	Inch	mm		lbs	kg	lbs	kg	ft	m	ft	m
LCMG-6	1/4	6	Galvanized Steel	1200	544	12	5.44	2	0.61	20	6.1
LCMS-6	1/4	6	Stainless Steel	1200	544	12	5.44	2	0.61	20	6.1
LCMG-9	3/8	9	Galvanized Steel	2400	1089	24	10.89	3	0.91	20	6.1
LCLS-9	3/8	9	Stainless Steel	2400	1089	24	10.89	3	0.91	20	6.1

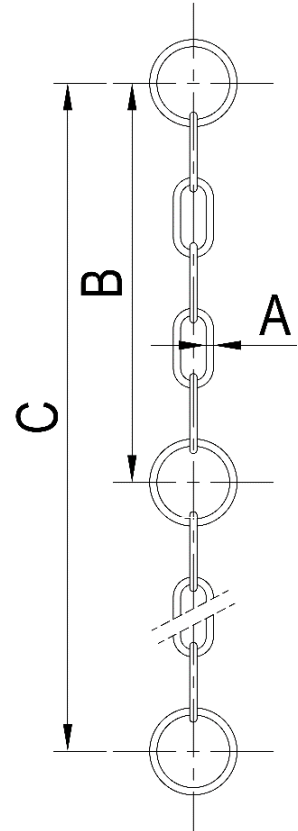

Application of QDC's Lifting Chain

QDC Model	Lifting Chain Model	
	Galvanized Steel	Stainless Steel
LM50	LCMG-6	LCMS-6
LM65		
LM80		
LL65	LCMG-9	LCLS-9
LL80		
LL100		
LL125		
LL150		
LL250U		
LL300U		
LL150YU		
LL200YU		
LL250YU		
LL300YU		
LME50	LCMG-6	LCMS-6
LME65		
LME80		
LLE65	LCMG-9	LCLS-9
LLE80		
LLE100		
LLE125		
LLE150		
LLE250U		
LLE300U		

Standard Lengths = 20ft (6m)

To Attach Chain:

1. Unbolt Pump bail
2. Slide open end ring over bail
3. Re-bolt bail to pump top.

For chain lengths longer than 20 ft.:
Use "quick links" or shackles to join 20 ft. lengths.

Technical Information

Project:

Model:

Chk'd:

Date:

Vortex Pumps – Model DVU, DVFU**1. PRINCIPLES OF VORTEX PUMP**

When the vortex impeller rotates in the casing, it generates primary vortex (B) and secondary vortex (A) as shown in the drawing, and then pumps up water:

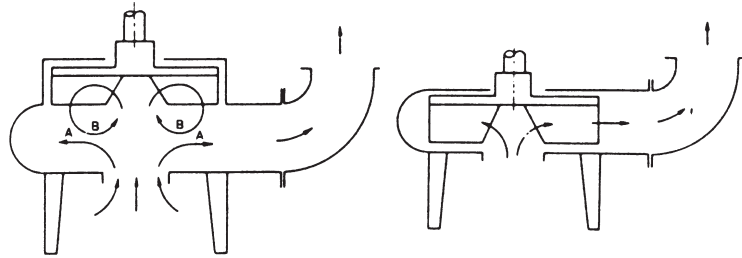

Vortex Pump

ORDINARY NON-CLOG PUMP

2. FEATURES

- a) As there is a large space between the impeller and the suction cover and there are no obstacles in the water passage, almost all sewage can be discharged without clogging.
- b) EBARA's unique hydraulic design of impeller and casing provide highly efficient performance which compares favorably with ordinary non-clog pump in spite of the large space.

Technical Information

Project: _____

Model: _____

Chk'd: _____

Date: _____

Clogging Phenomena and Prevention

From abundant experience, EBARA placed the following design concepts on sump and sewage pumps in order to prevent clogging.

CLOGGING PHENOMENA AT:

PREVENTION

1. Strainer Inlet

Choose a pump with a large strainer opening or pump without strainer.

2. Impeller Inlet

Shape inlet portion of the impeller blade as described below. The inlet edge of the impeller vanes are angled toward the impeller periphery so as to facilitate the release of objects that might otherwise clog the pump.

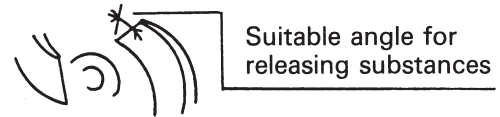

3. Clearance between Impeller and Suction Cover

Increase clearance – Model DVU, DVFU.

4. Casing Tongue

Provide large radius on tongue, or cut water.

5. Shaft End

Eliminate sharp points on impeller and impeller nut (use rounded impeller nut).

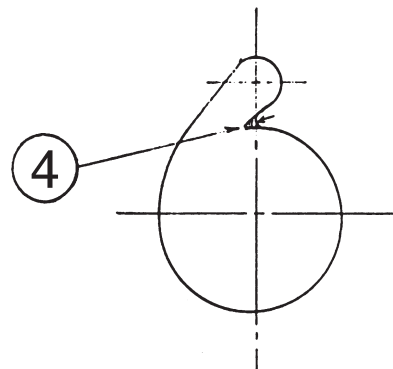
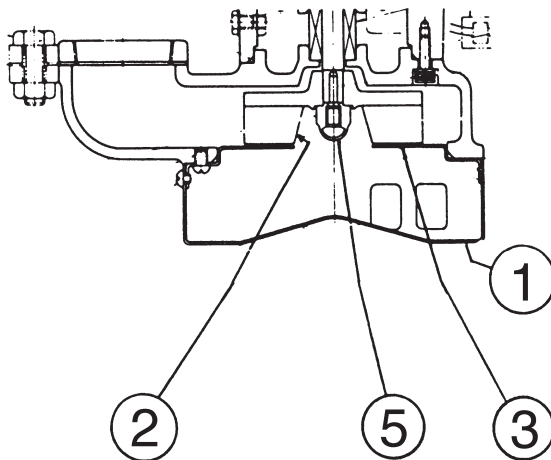

Technical Information

Project:

Model:

Chk'd:

Date:

Understanding Unbalance (1 of 5)

Three phase motors can be damaged by sustained application of unbalanced voltages. This problem can easily be more severe than application of balanced voltages above or below normal data plate ratings.

UNBALANCED PHASES

Unbalanced voltages applied to a 3 phase motor will adversely affect the motor operating characteristics. Motors will operate successfully where the variation in the supply voltage does not exceed plus or minus 10% of the name plate rating, but the voltages of a given 3 phase circuit should be evenly balanced as closely as can be read on the usually available commercial voltmeter. A relatively small unbalance in voltage will cause a considerable increase in temperature rise. For example, a 3.5% voltage unbalance will cause approximately 25% increase in temperature rise. The full load speed is reduced slightly when the motor operates on unbalanced voltages.

An unbalanced voltage will cause unequal currents to flow in the windings. If the motor is moderately or heavily loaded, currents in certain coils will exceed rating and overheat. Thermal cut-outs buried in the windings may detect this overheating and shut down the motor. If not, winding failure will result due to insulation damage.

A second type of damage is caused by rotor heating. This can occur without excessive coil current on a lightly loaded motor. Damaging currents at these frequencies will flow as a result of voltage unbalance. Rotors are not designed for such currents, especially those of recent design optimized by computer techniques. Rotor overheating is most likely to cause bearing or seal failure, again perhaps, after a long period of time. Thermal cut-outs in the stator seldom will detect this problem and starter failures have been charged to mechanical failure while the cause was actually voltage unbalance.

UNBALANCED CURRENTS

Questions relative to how much unbalance a motor can tolerate have been raised from time to time. This condition is generally due to voltage unbalance in the supply and can usually be corrected by working with the power company involved.

The effect of unbalanced phase currents is to increase the heating of the motor, thus reducing its efficiency. It might be said that unbalanced currents, as far as motor temperature rise is concerned, acts like additional load on the motor. For this reason the permissible loading decreases with increasing unbalance of phase currents.

Before a problem of this nature can be corrected, it is necessary to determine whether the source is with the **submersible motor** or with the **electrical supply furnished for its operation**. The following facts will assist in locating the source of the problem and will govern the steps to be taken in its correction.

Unbalanced amperage is generally caused by problems in either of the following areas:

- A. External power supply, including the pump control box.
- B. Internal problem with motor windings or stator leads to drop cable connection.

The following diagrams and explanation will present you with a method by which you can localize the problem as being caused by "A" or by "B". In other words, we are trying to find out whether the trouble lies in the area from the control back through the supply or whether it is a result of malfunction beyond the control down to and including the pump motor.



Technical Information

Project:

Model:

Chk'd:

Date:

Understanding Unbalance (2 of 5)

Assuming that the unit is connected to the supply so that the 3 phase motor is running in the **correct direction of rotation**, there are two other combinations of connection that will change phase connections but not change the rotation. This is accomplished by changing the position of **all three** drop cable leads at their termination in the control. It is important that all three leads be interchanged each time as the interchanging of only two leads will result in reversing the motor.

If any two pump cable power leads are interchanged in the control it will change the rotation of the motor.

If all three leads are interchanged in the control, the pump will continue to operate in the original rotation.

Once the three power leads in the pump cable are connected to the terminals in the control so that the pump is operating in the correct direction of rotation, there are two other possible combinations that will also operate the pump in the correct direction.

• EXAMPLE

Assuming that combination #1 is operating in correct rotation the 2nd and 3rd combination will also operate in the correct rotation.

If combination #1 shows unbalanced amperage readings, it is sometimes possible that one of the other two combinations above will operate at a lesser degree of unbalance.

Combination	T1	T2	T3
1st →	Red	Black	White
2nd →	Black	White	Red
3rd →	White	Red	Black

If the unbalanced leg follows the same wire in the drop cable from the pump, regardless of which position it is connected to on the control terminals the fault would most likely be found in the stator windings or in the stator leads to drop cable connections.

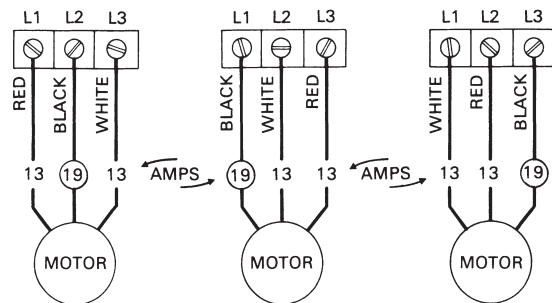

If the unbalanced leg remains related to the same terminal in the control box regardless of which wire is connected to it, the fault would most likely be found in the power supply or possibly poor connection in the control.

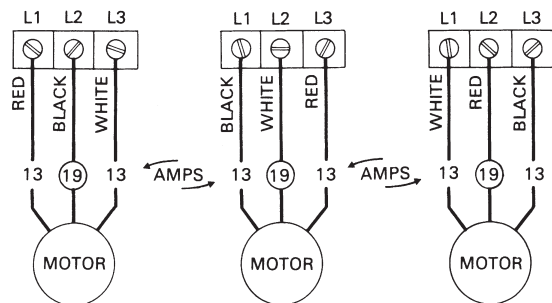

Technical Information

Project:

Model:

Chk'd:

Date:

Understanding Unbalance (3 of 5)

GENERAL CAUSES OF UNBALANCE

1. Extreme case as in Single Phasing of a 3 phase supply. The source may be in the control. Either a blown fuse, defective or poor contact point in contactor or any interruption in wiring or terminals.
2. Pulling single phase loads from the 3 phase supply in an unbalanced sequence. This can be especially true in a job shop where electrical load is unpredictable at any given time.

As we are speaking of Voltage and Amperage in terms of percentage of Unbalance, the question arises as to how to figure the % of unbalance in a three phase system. The formula reads as follows:

$$\frac{\text{Maximum Deviation from average}}{\text{Average of the 3 readings}} \times 100 = \text{Percentage of Unbalance}$$

• EXAMPLE

L1—L2 = 234V	Average of the 3 readings: 229V
L1—L3 = 230V	Maximum deviation from the average: 229—223=6V
L2—L3 = 223V	Voltage unbalance : 6/229 x 100 = 2.62%
L1 = 63.3 amps	Average of the 3 readings: 61.1 amps
L2 = 65.6 amps	Maximum deviation from the average: 61.1—54.4=6.7 amps
L3 = 54.4 amps	Amperage unbalance: 6.7/61.1 x 100 = 10.97%

Maximum permissible % of amperage unbalance allowed at motor full load is 5%. Permissible % of unbalance increases as motor load decreases. However, unless under specific conditions, the motor should, for safety, be considered to be operating at full load.

Maximum permissible % of Voltage unbalance allowed is 1%. Keep in mind that, especially with Delta wound motors, the true amperage unbalance is in the neighborhood of 6 to 10 times the voltage unbalance. The true amperage unbalance is not readily determined by the amperage readings taken in the supply lines. Excess circulating currents within the stator not recorded on your amp meter contribute to overheating of winding insulation.

The “maximum” percentages mentioned above are based on motors working at full load. Slightly higher maximums may be allowed at less than full load conditions but “good practice” and full warranty must necessarily be based on full load conditions especially with squirrel cage induction motors assigned to such variable conditions as is found in the pumping of liquids, etc.



Technical Information

Project:

Model:

Chk'd:

Date:

Understanding Unbalance (4 of 5)**EXPLANATION OF NEMA STANDARD MGI-1973-SECTION 14.34**

This standard presents guidelines on Voltage Unbalance.

While the voltages should be evenly balanced as closely as can be read on the usually available commercial voltmeter, it is recommended that any voltage unbalance at the Motor Terminals not exceed 1%.

Unbalanced Voltage can be broken into two opposing components, a positive sequence voltage and negative sequence voltage component. The positive sequence, operating the motor in its correct rotation, is opposed by the negative sequence, causing a build up of heat.

Unbalance causes extra motor losses and in turn heating of the Rotor and Windings. Increased motor losses increase power costs.

Line currents, as a result of unbalanced voltage, will be greatly unbalanced in the order of 6 to 10 times the voltage unbalance. This true value of the current unbalance will not be apparent on a normal reading, as part of the unbalance is in the form of circulating currents in the motor and does not show up in the line. It is recommended that any amperage unbalance at the motor terminals not exceed 5%.

In the phase with the highest current, the percentage increase in temperature rise will be approximately two times the square of the percentage of voltage unbalance.

• EXAMPLE

If voltage unbalance was 3%, percentage increase in temperature rise would be:

$$2 \ (3\%)^2 = 2 \ 9\% = 18\%$$



Technical Information

Project:

Model:

Chk'd:

Date:

Understanding Unbalance (5 of 5)

Any significant voltage unbalance notably reduces the margins that motors have at usual service conditions, i.e. Service Factor. Voltage Unbalance can be more harmful than short time overloading or moderate low voltage conditions.

• NOTE

If the unbalance condition cannot be corrected, it would then be advisable to reduce the motor load or oversize the motor.

EFFECT OF VOLTAGE VARIATION ON INDUCTION MOTOR CHARACTERISTICS

