

D10 PRO SERIES

Maximum Flow Rate: 8.8 gpm (33.4 l/min)

Maximum Pressure: 1500 psi (103 bar) for Metallic Pump Heads
350 psi (24 bar) for Non-metallic Pump Heads

WANNER™ HYDRA-CELL® PRO SEAL-LESS PUMP TECHNOLOGIES

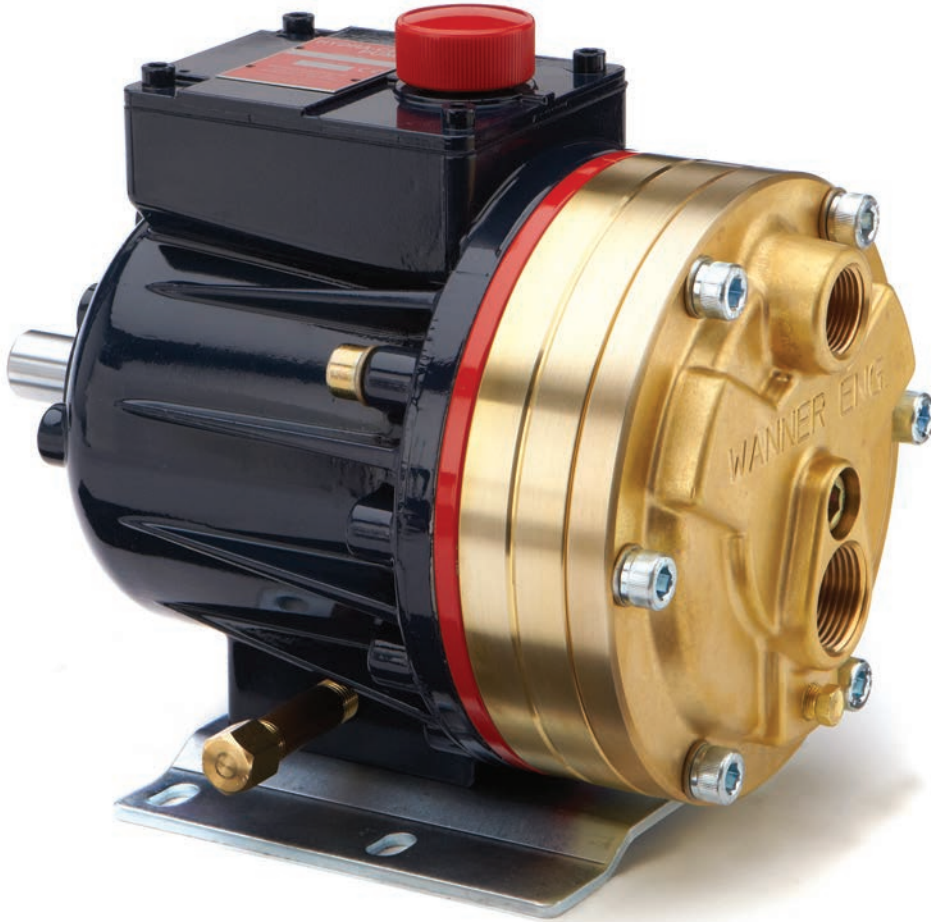

D10 Pro with brass pump head.

A higher standard of pump performance and efficiency.

- Integrates **Wanner Hydra-Cell® Pro** seal-less pump technologies for the highest levels of volumetric and energy efficiencies across a full rpm range.
- Seal-less design API 674 pumps that also exceed API 675 standards for accuracy, linearity and repeatability.
- True positive displacement pumping action achieves overall efficiency of >90%, targeting improvements at lower speeds and higher pressures.
- No mechanical dynamic seals, packing, or cups to leak, wear or replace – reduces maintenance, costs and downtime.
- Pumped liquid is 100% contained – prevents degradation, contamination and environmental risks.
- Patented ADPC (Advanced Diaphragm Position Control) and hydraulic oil management system protects diaphragms under closed or restricted inlet conditions.
- Can run dry indefinitely without damage to the pump.
- Reliably handles a wide range of viscosities and shear sensitivities, corrosive liquids, abrasives, slurries and particulates.
- Reduced ownership costs in acquisition, operation, service, maintenance, and energy use.

D10 Pro Series | Performance

Capacities

Model	Max. Input rpm	Max. Flow Capacities @1000 psi (69 bar)		Max. Inlet Pressure		Max. Discharge Pressure					
		gpm	l/min	psi	bar	Metallic Heads		Polypropylene Heads		PVDF Heads	
						psi	bar	psi	bar	psi	bar
D10-X	1450	8.1	30.6	250	17	1000	69	250	17	350	24
D10-E	1750	8.8	33.4	250	17	1000	69	250	17	350	24

Model	Max. Input rpm	Max. Flow Capacities @1500 psi (103 bar)		Max. Inlet Pressure		Max. Discharge Pressure Metallic Heads	
		gpm	l/min	psi	bar	psi	bar
D10-X	790	4.26	15.1	250	17	1500	103
D10-E	790	3.87	14.7	250	17	1500	103

Performance and specification ratings apply to D10 configurations unless specifically noted otherwise.

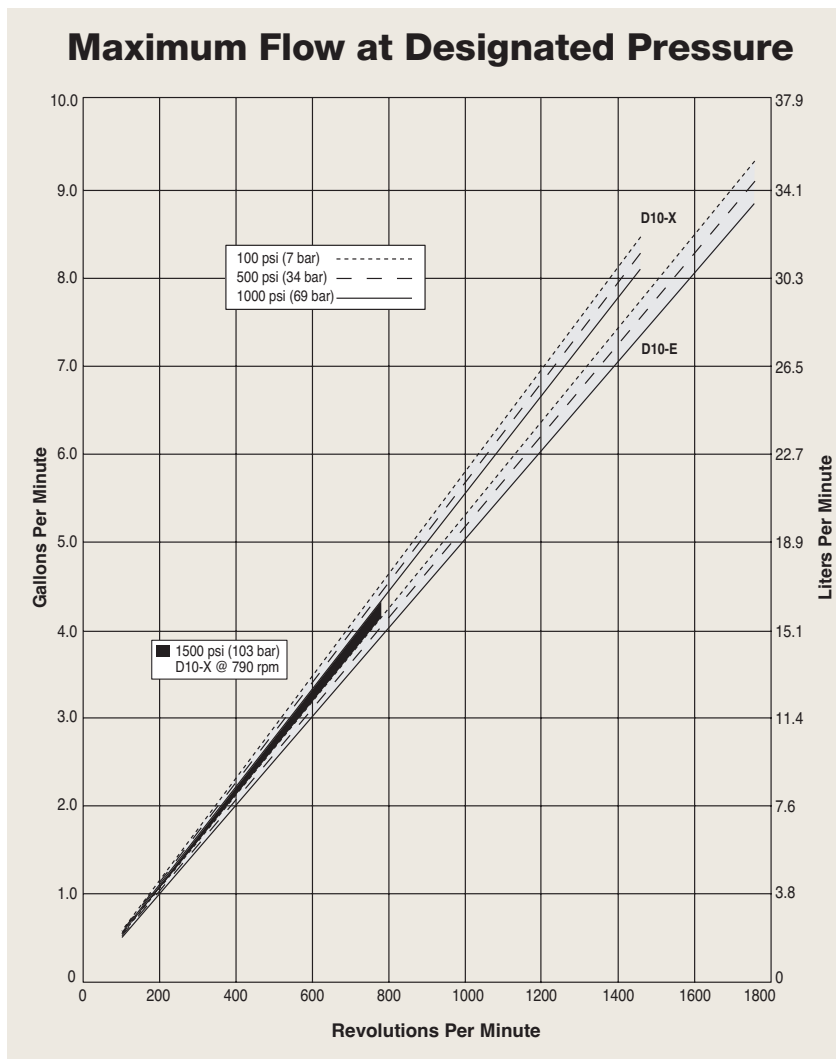

Due to the Wanner Engineering Continuous Improvement Program, specifications and other data are subject to change.

D10 Pro Series | Specifications

Flow Capacities @1000 psi (69 bar)

Model	rpm	gpm	l/min
D10-X	1450	8.10	30.6
D10-E	1750	8.83	33.4

Delivery @1000 psi (69 bar)

Model	gal/rev	liters/rev
D10-X	0.0056	0.0211
D10-E	0.0051	0.0191

Delivery @1500 psi (103 bar)

Model	gal/rev	liters/rev
D10-X	0.0054	0.0205
D10-E	0.0049	0.0186

Maximum Discharge Pressure

Metallic Heads:	1000 psi (69 bar) @1450 rpm (D10-X)
	1000 psi (69 bar) @1750 rpm (D10-E)
	1500 psi (103 bar) @790 rpm (D10-X)
Non-metallic Heads:	250 psi (17 bar) Polypropylene
	350 psi (24 bar) PVDF

Maximum Inlet Pressure 250 psi (17 bar)

Maximum Operating Temperature

Metallic Heads:	250°F (121°C)
	Consult factory for correct component selection for temperatures from 160°F (71°C) to 250°F (121°C).
Non-metallic Heads:	140°F (60°C)

Maximum Solids Size 500 microns

Inlet Port	1 inch NPT
	150lb ANSI RF flange

Calculating Required Power

$$\frac{15 \times \text{rpm}}{63,000} + \frac{\text{gpm} \times \text{psi}}{1,460} = \text{electric motor hp}$$

$$\frac{15 \times \text{rpm}}{84,428} + \frac{\text{l/min} \times \text{bar}}{511} = \text{electric motor kW}$$

Attention!

When using a variable frequency drive (VFD) controller, calculate the hp or kW at minimum and maximum pump speed to ensure the correct hp or kW motor is selected. Note that motor manufacturers typically de-rate the service factor to 1.0 when operating with a VFD.

Calculating Pulley Size

$$\frac{\text{motor pulley OD}}{\text{pump rpm}} = \frac{\text{pump pulley OD}}{\text{motor rpm}}$$

Due to the Wanner Engineering Continuous Improvement Program, specifications and other data are subject to change.

Discharge Port	3/4 inch NPT
	600lb ANSI RF flange

Shaft Diameter	7/8 inch (22.2 mm)
----------------	--------------------

Shaft Rotation	Reverse (bi-directional)
----------------	--------------------------

Bearings	Tapered roller bearings
----------	-------------------------

Oil Capacity	1.1 US quarts (1.05 liters)
--------------	-----------------------------

Weight

Metallic Heads:	48 lbs. (21.8 kg)
Non-metallic Heads:	35 lbs. (15.9 kg)

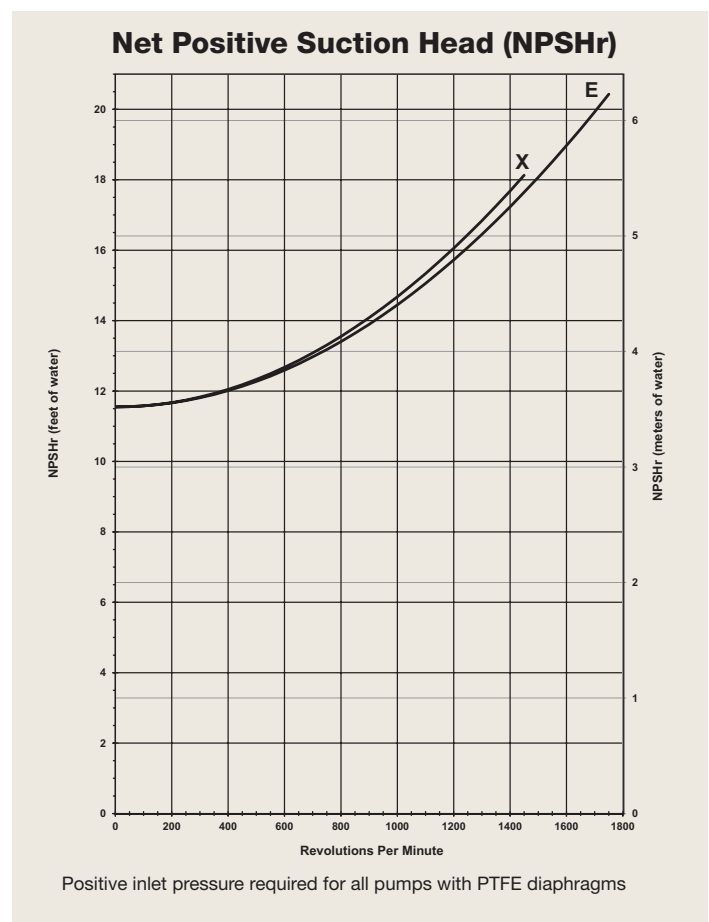

Suction Lift

Each Hydra-Cell pump has different lift capability depending on model size, cam angle, speed, and fluid characteristics. To ensure that your specific lift characteristics are met, refer to the inlet calculations regarding friction, and acceleration head losses in your Hydra-Cell Product Manual. Compare those calculations to the NPSHr curves above.

D10 Pro Series | Representative Drawings

D10 Models with Metallic Pump Head Inches (mm)

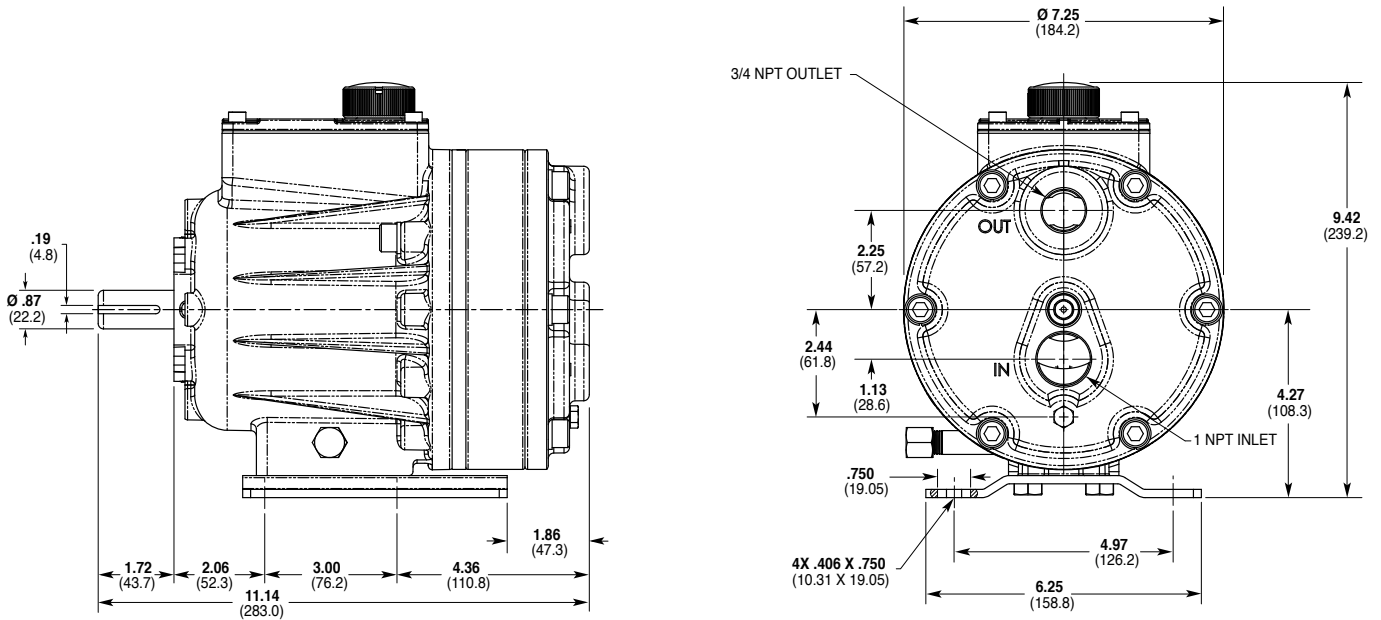

D10 Models with Non-metallic Pump Head Inches (mm)

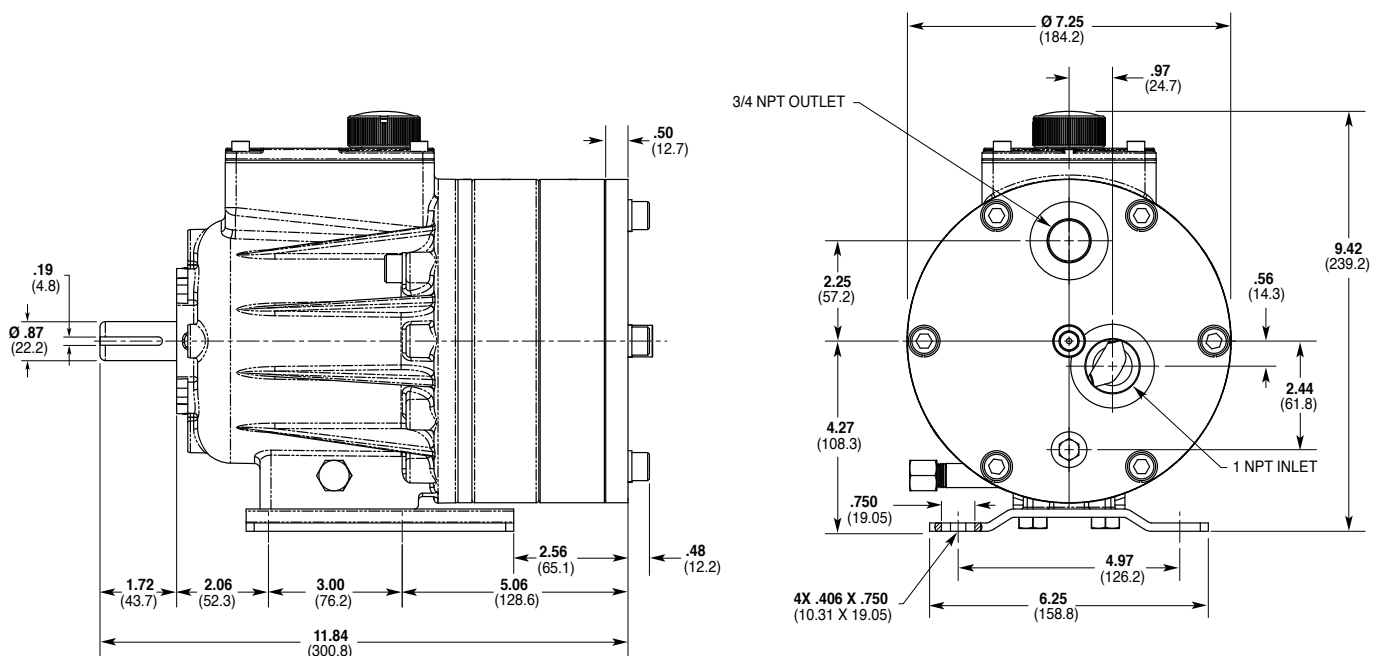

Note: Dimensions are for reference only. Contact factory for certified drawings.

D10 Pro Series | Adapters / Valves

Pump/Motor Adapter Inches (mm)

Part Number: A04-001-1200

For: 56C, 143TC and 145TC frame motors.

Metric adapter available - consult factory.

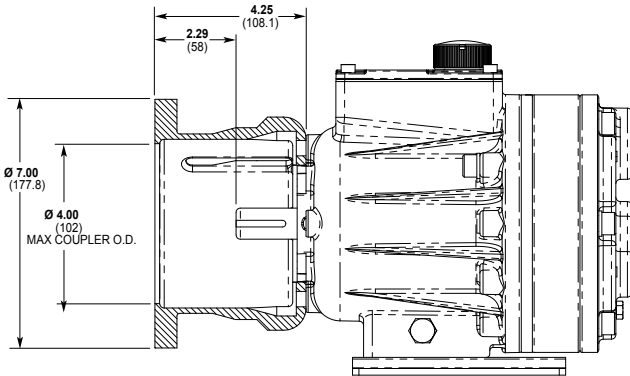

Part Number: A04-002-1200

For: 182TC, 184TC, 213TC and 215TC frame motors.

Metric adapter available - consult factory.

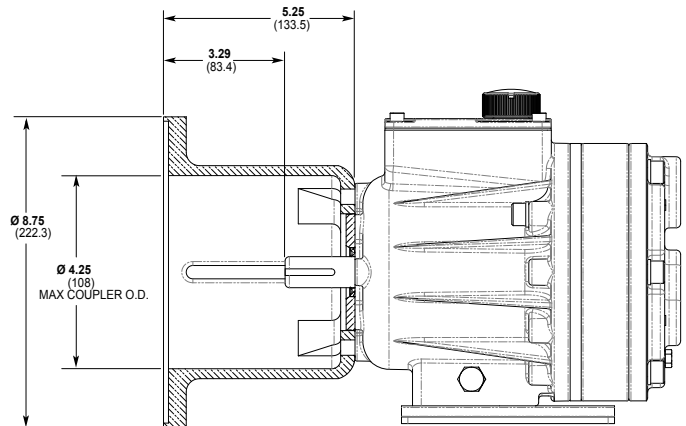

Note: Dimensions are for reference only. Contact factory for certified drawings.

Valve Selection

A seal-less **C62 Pressure Regulating Valve** is recommended for Hydra-Cell Pro D10 pumping systems, especially for high-pressure requirements or when handling dirty fluids.



A **C22 Pressure Regulating Valve** provides a capable, lower-cost alternative to C62 valves for Hydra-Cell Pro D10 pumping systems.



Skid-mounted D10 Pro.

For complete specifications and ordering information, consult the Hydra-Cell Master Catalog.

D10 Pro Series | Options

Consult the Hydra-Cell Master Catalog for:

- Motors, bases, couplings and other pump accessories
- Hydra-Oil selection and specification information
- Design considerations, installation guidelines, and other technical assistance in pump selection

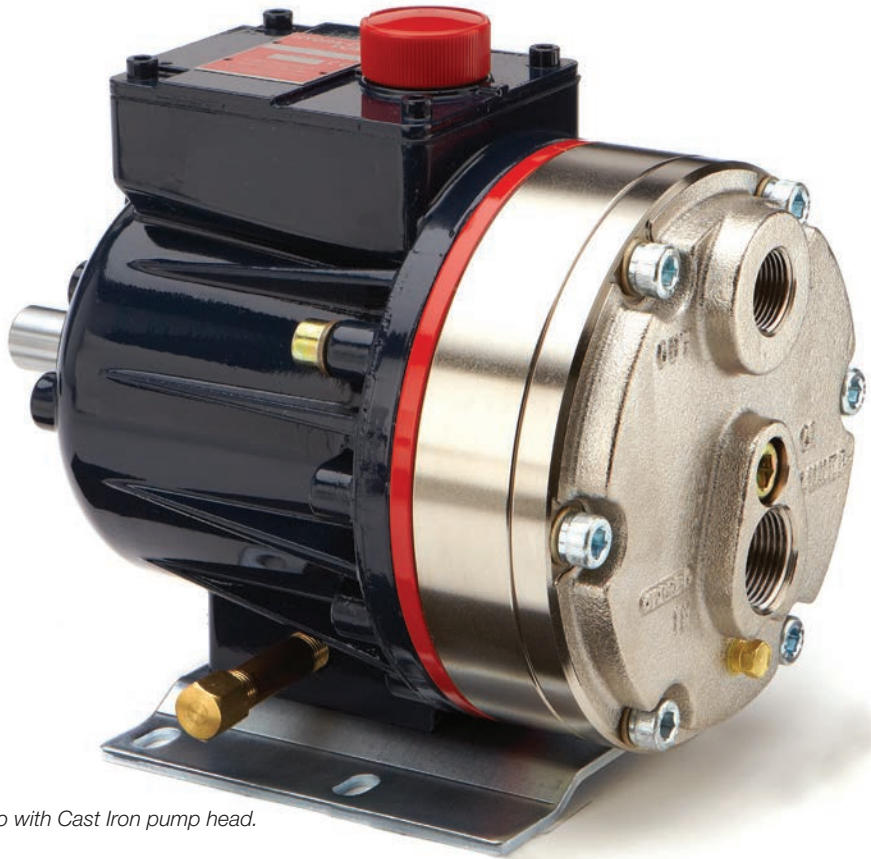

D10 Pro with Cast Iron pump head.



D10 Pro with Brass pump head.



D10 Pro with Polypropylene pump head.



D10 Pro with 316L Stainless Steel pump head and ANSI flanges.

D10 Pro Series | How to Order

Ordering Information

A complete D10 Series Model Number contains 12 digits including 8 customer-specified design and materials options, for example: D10XPCTHFECA.

1	2	3	4	5	6	7	8	9	10	11	12
D	1	0		P							

Digit	Order Code	Description
1-3	D10	Pump Configuration Shaft-driven (NPT Ports or ANSI Flanges)* *Pump/motor adapters ordered separately. See page 5.
4	X E	Hydraulic End Cam Max 8.1 gpm (30.6 l/min) @ 1450 rpm Max 8.8 gpm (33.4 l/min) @ 1750 rpm
5	P	Pump Head Version Hydra-Cell Pro
6	B C G M N R S T	Pump Head Material Brass Cast Iron (Nickel-plated) Duplex Alloy 2205 Stainless Steel (with Hastelloy C followers & follower screws) PVDF (with Hastelloy C followers & follower screws) Polypropylene (with Hastelloy C followers & follower screws) 316L Stainless Steel ANSI flange class 150 x 600 316L Stainless Steel Hastelloy CW12MW
7	A E G J P T	Diaphragm & O-ring Material Aflas diaphragm / PTFE O-ring EPDM (requires EPDM-compatible oil – Digit 12 oil code C) FKM PTFE (available with E cam only; 1200 rpm max.) Neoprene Buna-N
8	C D H S T	Valve Seat Material Ceramic Tungsten Carbide 17-4 Stainless Steel 316L Stainless Steel Hastelloy C

Digit	Order Code	Description
9	C D F N T	Valve Material Ceramic Tungsten Carbide 17-4 Stainless Steel Nitronic 50 Hastelloy C
10	E T	Valve Springs Elgiloy Hastelloy C
11	C H M P T Y	Valve Spring Retainers Celcon 17-7 Stainless Steel (used with metallic heads only) PVDF Polypropylene Hastelloy C (used with metallic heads only) Nylon (Zytel)
12	A B C E G H	Hydra-Oil 10W30 standard-duty oil 40-wt for continuous-duty oil (use with 316L SST or Hastelloy CW12MW pump head – standard) 30-wt EPDM-compatible oil Food-contact oil 5W30 cold-temp severe-duty synthetic oil 15W50 high-temp severe-duty synthetic oil

D10 Pump Housing is standard as Cast Aluminum.
Upgrade to Ductile Iron available.

Partners in over 70 countries





WANNER™
Global Sales and Technical Support



Americas

-  Minneapolis, Minnesota USA
-  Wichita Falls, Texas USA
-  São Paulo, Brazil
-  Buenos Aires, Argentina





EMEA | Australia

-  Hampshire, United Kingdom
-  Cairo, Egypt
-  Remagen, Germany

Asia | Pacific

-  Kowloon, Hong Kong
-  Shanghai, China
-  Jakarta, Indonesia

India

-  Mumbai, India
-  New Delhi
-  Bangalore
-  Gujarat

Wanner worldwide

GLOBAL SALES & TECHNICAL SUPPORT

WANNER ENGINEERING, INC.

WORLD HEADQUARTERS & MANUFACTURING

Minneapolis, Minnesota USA
t: 612-332-5681
e: sales@wannereng.com
Hydra-Cell.com

REGIONAL OFFICE

Wichita Falls, Texas USA
t: 940-322-7111
e: sales@wannereng.com

LATIN AMERICAN OFFICE

São Paulo, Brazil
t: +55 (11) 99582-1969
e: mmagoni@wannereng.com
Hydra-Cell-Pumps.com.br

WANNER INTERNATIONAL, LTD.

UNITED KINGDOM

Church Crookham,
Hampshire UK GU52 8BF
t: +44 (0) 1252 816847
e: support@wannerint.com
Hydra-Cell.co.uk

WANNER PUMPS, LTD.

Kowloon, HONG KONG
t: +852 3428 6534
e: sales@wannerpumps.com
WannerPumps.com

Shanghai, CHINA
t: +86-21-6876 3700
e: sales@wannerpumps.com
WannerPumps.com

WANNER INDIA PVT. LTD.

Mumbai, INDIA
t: +91 (22) 22044766
e: support@wannerindia.com
WannerIndia.com

