

**D-10 (NEMA)  
G-10 (IEC)**

**Adapter Kit:  
A04-001-1200  
A04-003-1200**

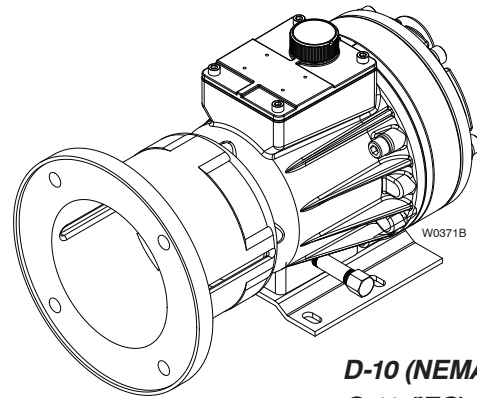

**D-10 (NEMA)  
G-10 (IEC)**

**Adapter Kit:  
A04-002-1200  
A04-004-1200**

Part Number Description

A04-001-1200 D-10 Pump/Motor Adapter Kit for NEMA 56C,143/145TC C-Face Motors

A04-002-1200 D-10 Pump/Motor Adapter Kit for NEMA 182/184TC and 213/215TC C-Face Motors

A04-003-1200 G-10 Pump/Motor Adapter Kit for IEC 80-90 B5 Flange Motors

A04-004-1200 G-10 Pump/Motor Adapter Kit for IEC 100-112 B5 Flange Motors

### Dimensions

inches (mm)

**Adapter: A04-001-1200; A04-003-1200**

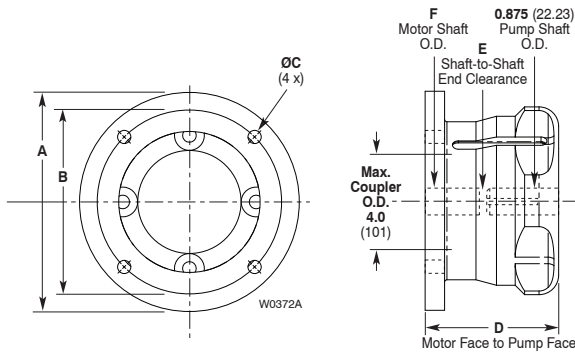

**Adapter: A04-002-1200; A04-004-1200**

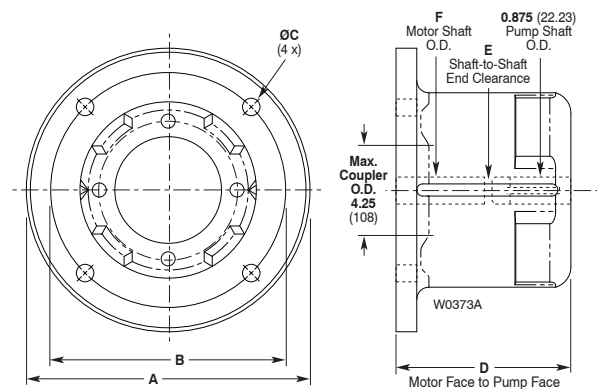

Kit Part Number	Adapter Kit Motor Size	Dimensions in (mm)					
		A	B	C	D	E	F
A04-001-1200	NEMA 56C	7.00	5.875	0.42	4.25	0.76	0.625
	NEMA 143/145TC	7.00	5.875	0.42	4.25	0.70	0.875
A04-002-1200	NEMA 182/184TC	8.75	7.25	0.54	5.30	1.12	1.125
	NEMA 213/215TC	8.75	7.25	0.54	5.30	0.37	1.375
A04-003-1200	IEC 80 B5 Flange	—	(165)	(10.7)	(108)	(31.8)	(19)
	IEC 90 B5 Flange	—	(165)	(10.7)	(108)	(21.7)	(24)
A04-004-1200	IEC 100-112 B5 Flange	(248)	(215)	(12.7)	(137)	(32.6)	(28)



**WANNER ENGINEERING, INC.**

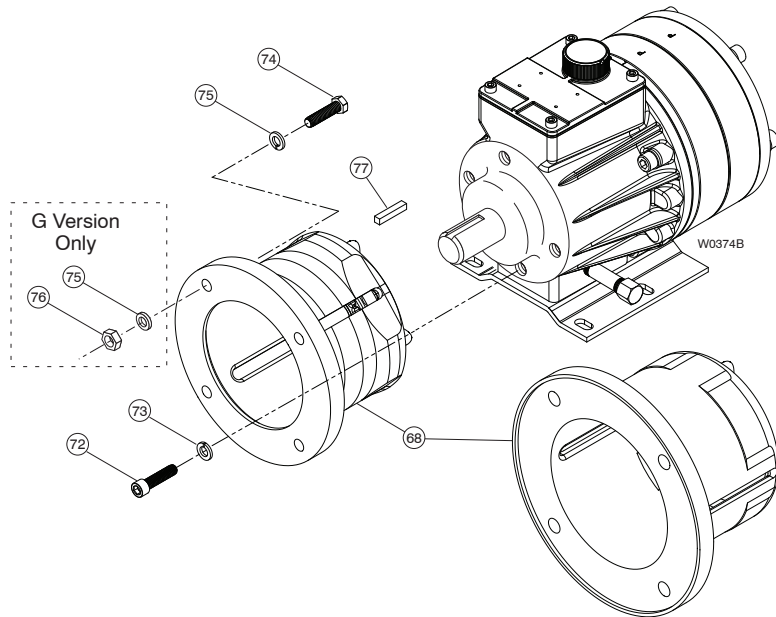

### Installation:

Fasten pump/motor adapter to pump using socket-head cap screws (72) with lockwashers (73).

Attach coupling hubs (not included in Adapter Kit), to pump and motor shafts. Slide coupling sleeve onto pump shaft coupling hub, then engage onto motor coupling hub.

Assemble adapter to motor using hex-head cap screws (74) and lockwashers (75). IEC motors use additional lockwashers (75) and nuts (76).

Make any adjustments to the position of the coupling hubs through the access slots in the sides of the adapter. Tighten coupling sleeve set screws.

### Adapter Kit Contents:

Ref No.	Description	A04-001-1200		Quantity/Kit	A04-003-1200		A04-004-1200	
		56C/145TC Part Number	182/215TC Part Number		80-90 Part Number	100-112 Part Number	Quantity/Kit	
68	Pump/Motor Adapter	A04-031-1000 <sup>1</sup> A04-032-1050 <sup>2</sup>	A04-030-1000 <sup>1</sup> A04-033-1050 <sup>2</sup>	1	A04-031-1001 <sup>1</sup> A04-032-1051 <sup>2</sup>	A04-030-1001 <sup>1</sup> A04-033-1051 <sup>2</sup>		1
69*	Adapter Baseplate	A04-025-1010 <sup>1</sup>	—	1	A04-025-1010 <sup>1</sup>	—		1
70*	Screw, Cap, Hex-hd, 3/8 in.	D10-029-2010 <sup>1</sup>	—	4	D10-029-2010 <sup>1</sup>	—		4
71*	Lockwasher, Internal tooth, 3/8 in.	D10-054-2010 <sup>1</sup>	—	4	D10-054-2010 <sup>1</sup>	—		4
72	Screw, Cap, Soc-hd, 3/8 in.	A04-041-2010 <sup>1</sup> G10-089-2010 <sup>2</sup>	A04-041-2010 <sup>1</sup> G10-089-2010 <sup>2</sup>	4	G10-089-2010 M10	G10-089-2010 M10		4
73	Lockwasher, Split, 3/8 in.	D10-048-2010 <sup>1</sup> G25-048-2011 <sup>2</sup>	D10-048-2010 <sup>1</sup> G25-048-2011 <sup>2</sup>	4	G25-048-2011 M10	G25-048-2011 M10		4
74	Screw, Cap, Hex-hd, 3/8 in.	D03-068-2010	M10-110-2000 1/2 in.	4	A04-046-2010 M10	A04-043-2010 M12		4
75	Lockwasher, Split, 3/8 in.	D10-048-2010	M10-111-2000 1/2 in.	4	A04-044-2010 M10	M10-111-2000 1/2 in.		8
76	Hex Nut	—	—		A04-047-2010 M10	A04-045-2010 M12		4
77	Short Key	A04-085-2210	A04-085-2210	1	A04-085-2210	A04-085-2210		1

<sup>1</sup> Used on D/G10 models prior to S/N 216283.

<sup>2</sup> Used on D/G10 models S/N 216283 and above.

\* Not shown.



## WANNER ENGINEERING, INC.

1204 Chestnut Avenue, Minneapolis, MN 55403

TEL: (612) 332-5681 FAX: (612) 332-6937

TOLL-FREE FAX [US only]: (800) 332-6812

www.hydra-cell.com email:sales@wannereng.com