

Champion Pump Company, Inc.

INSTALLATION MANUAL Submersible Effluent & Sewage

PLEASE FILL OUT THE START-UP REPORT/WARRANTY
REGISTRATION ON THE LAST PAGE

****REPORTS THAT ARE NOT RETURNED CAN DELAY
OR VOID THE WARRANTY****

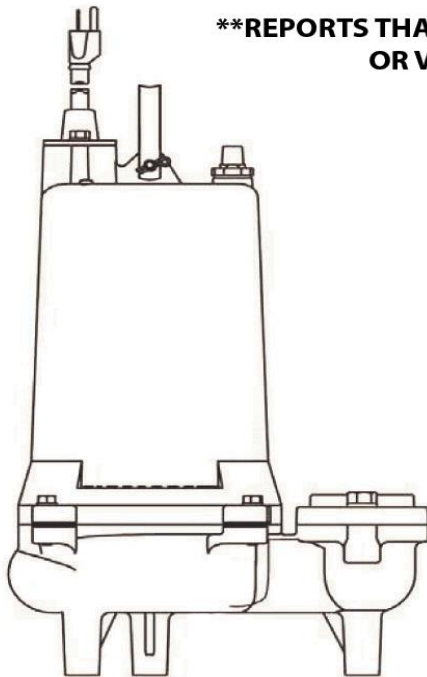

**CPSTEP5 Series
CPSTEP10 Series
CPSTEP15 Series
CPSTEP20 Series**

**CPSE/V5 Series
CPSE/V10 Series
CPSE/V15 Series
CPSE/V20 Series
CPSEVH20 Series**



**PUMP SUPPLY
INCORPORATED**

IMPORTANT! Read all Instructions in this manual before operating pump.
Champion Pump Company, Inc. reserves the right to change product
without written consent.

**Champion Pump Company, Inc.
P.O. Box 528
Ashland, OH 44805
Phone: 419-281-4500
Fax: 419-616-1100
www.championpump.com**

Rev. 04/20



SAFETY FIRST!

Please Read This Before Installing Or Operating Pump. This information is provided for **SAFETY and to PREVENT EQUIPMENT PROBLEMS**. To help recognize this information, observe the following symbols:



IMPORTANT! Warns about hazards that can result in personal injury or Indicates factors concerned with assembly, installation, operation, or maintenance which could result in damage to the machine or equipment if ignored.

CAUTION ! Warns about hazards that can or will cause minor personal injury or property damage if ignored. Used with symbols below.

WARNING ! Warns about hazards that can or will cause serious personal injury, death, or major property damage if ignored. Used with symbols below.



Hazardous fluids can cause fire or explosions, burns or death could result.



Extremely hot - Severe burns can occur on contact.



Biohazard can cause serious personal injury.



Hazardous fluids can Hazardous pressure, eruptions or explosions could cause personal injury or property damage.



Rotating machinery Amputation or severe laceration can result.



Hazardous voltage can shock, burn or cause death.

Only qualified personnel should install, operate and repair pump. Any wiring of pumps should be performed by a qualified electrician.



WARNING ! - To reduce risk of electrical shock, pumps and control panels must be properly grounded in accordance with the National Electric Code (NEC) or the Canadian Electrical Code (CEC) and all applicable state, province, local codes and ordinances.

WARNING! - To reduce risk of electrical shock, always disconnect the pump from the power source before handling or servicing. Lock out power and tag.

Prevent large articles of clothing, large amounts of chemicals, other materials or substances such as are uncommon in domestic sewage from entering the system.

During power black-outs, minimize water consumption at the home(s) to prevent sewage from backing up into the house.

Always keep the shut-off valve completely open when system is in operation (unless advised otherwise by the proper authorities). Before removing the pump from the basin, be sure to close the shut-off valve. (This prevents backflow from the pressure sewer.)

Keep the control panel locked or confined to prevent unauthorized access to it.

If the pump is idle for long periods of time, it is advisable to start the pump occasionally by adding water to the basin.



CAUTION! Pumps build up heat and pressure during operation-allow time for pumps to cool before handling or servicing.



WARNING! - **DO NOT** pump hazardous materials (flammable, caustic, etc.) unless the pump is specifically designed and designated to handle them.

Do not block or restrict discharge hose, as discharge hose may whip under pressure.



WARNING! - **DO NOT** wear loose clothing that may become entangled in the impeller or other moving parts.

WARNING! - Keep clear of suction and discharge openings. **DO NOT** insert fingers in pump with power connected.

Make sure lifting handles are securely fastened each time before lifting. Do not operate pump without safety devices in place. Always replace safety devices that have been removed during service or repair.

Do not exceed manufacturers recommendation for maximum performance, as this could cause the motor to overheat.

Secure the pump in its operating position so it can not tip over, fall or slide.

Cable should be protected at all times to avoid punctures, cut, bruises and abrasions - inspect frequently.



Never handle connected power cords with wet hands.

To reduce risk of electrical shock, all wiring and junction connections should be made per the NEC or CEC and applicable state or province and local codes. Requirements may vary depending on usage and location.



Submersible Pumps are not approved for use in swimming pools, recreational water installations, decorative fountains or any installation where human contact with the pumped fluid is common.

Do not remove cord and strain relief. Do not connect conduit to pump.



Products Returned Must Be Cleaned, Sanitized, Or Decontaminated As Necessary Prior To Shipment, To Insure That Employees Will Not Be Exposed To Health Hazards In Handling Said Material. All Applicable Laws And Regulations Shall Apply.



Bronze/brass and bronze/brass fitted pumps may contain lead levels higher than considered safe for potable water systems. Lead is known to cause cancer and birth defects or other reproductive harm. Various government agencies have determined that leaded copper alloys should not be used in potable water applications. For non-leaded copper alloy materials of construction, please contact factory.



IMPORTANT! - Champion Pump Company is not responsible for losses, injury, or death resulting from a failure to observe these safety precautions, misuse or abuse of pumps or equipment.

USER GUIDE

Congratulations on your purchase of a Champion Pump. With proper care and by following a few simple guidelines, your pump will give you many years of dependable service.

USE & CARE The Champion Effluent & Sewage pumps are designed to handle routine, domestic effluent & sewage. Solid waste materials should be thrown in the trash. While your station is capable of accepting and pumping a wide range of materials, regulatory agencies advise that the following items should not be introduced into any sewer either directly or through a kitchen waste disposal: glass; metal; diapers; socks, rags or cloth; plastic objects (e.g., toys, utensils, etc.) sanitary napkins or tampons.

In addition you must never introduce into any sewer: Explosives; flammable material; lubricating oil and or grease; strong chemicals; gasoline.

POWER FAILURE This pump cannot dispose of wastewater or provide an alarm signal without electrical power. If electrical power service is interrupted, keep water usage to a minimum.

WARRANTY Your pump is furnished with a warranty against defects in material or workmanship. A properly completed Start-Up/Warranty Registration form must be on file at the Champion factory in order to activate your warranty. In addition, your pump must be installed in accordance with the installation instructions. If you have a claim under the provisions of the warranty, contact your installer.

For future reference, record the following information:

<u>Pump Model #</u>	<u>Pump Serial #</u>	
<u>Installer</u>	<u>Installer Phone #</u>	<u>Date</u>
<u>Installed</u>		

RECEIVING / UNPACKING Upon receiving the pump, it should be inspected for damage or shortages. If damage has occurred, file a claim immediately with the company that delivered the pump. Unpack pump and record pump serial and model number before installing. If the manual is removed from the packaging, do not lose or misplace.

SHORT TERM STORAGE For best results, pumps can be retained in storage, as factory assembled, in a dry atmosphere with constant temperatures for up to six (6) Months.

LONG TERM STORAGE Any length of time exceeding six (6) months, but not more than twenty-four (24) months. The units should be stored in a temperature controlled area, a roofed over walled enclosure that provides protection from the elements (rain, snow, wind-blown dust, etc.), and whose temperature can be maintained between +40 deg. F and +120 deg.F. If extended high humidity is expected to be a problem, all exposed parts should be inspected before storage and all surfaces that have the paint scratched, damaged, or worn should be recoated with an air dry enamel paint. All surfaces should then be sprayed with a rust-inhibiting oil. Pump should be stored in its original shipping container. On initial start up, rotate shaft by hand to assure seal and motor rotate freely.



USER GUIDE

INSTALLATION Assemble discharge piping or hose assembly to the pump. Discharge piping should be as short as possible. Both a check valve and a shut off valve are required for each pump being used. The check valve is used to prevent backflow into the sump. Excessive backflow can cause flooding and /or damage to the pump. The shut-off valve is used to stop system flow during pump or check valve servicing. If pump is installed with a discharge hose rather than a moveable fitting assembly, make sure the discharge pipe has a 1/8" hole approximately 5" from the end nearest the volute and oriented towards the pump body.

ELECTRICAL CONNECTIONS

A **25-30 AMP** breaker is recommended for 1/2HP 115V and 2HP 230V Single phase models. 20 AMP for all others.

The quick connect cord assembly mounted to the pump must not be modified in any way except for shortening to a specific application. Any supply cables connections between the pump and the control panel must be made in accordance with the National Electric Code or the Canadian Electric Code and all applicable state, province and local electric codes. It is recommended that a junction box, be mounted outside the sump or be of at least Nema 4 (EEMAC-4) construction if located within the wet well. The ground wire of the pump is marked with an "E" for earth ground and/or is a blue/green color. If additional cord is required, consult a qualified electrician for proper wire size. **DO NOT USE THE POWER OR CONTROL CABLES TO LIFT PUMP!**

On single phase models, the type of in-winding overload protector used is referred to as an inherent overheating protector and operates on the combined effect of temperature and current. This means that the overload protector will trip out and shut the pump off if the winding becomes too hot, or the load current passing through them becomes too high. It will then automatically reset and start the pump up after the motor cools to a safe temperature. All three phase models are not automatically protected. They do have on winding thermal sensors accessed through the sensor cord (black and green wires) that need to be connected to an approved protection and alarm circuit in the control panel for winding thermal protection. **Thermal protection shall not be used as a motor overload device. A separate motor overload device must be provided in accordance with NEC Codes.** In the event of an overload, the source of this condition should be determined and rectified immediately. **DO NOT LET THE PUMP CONTINUE TO RUN IF AN OVERLOAD CONDITION OCCURS.**

OPTIONAL MOISTURE SENSOR: On single phase double seal models, a detector is installed in the pump seal chamber which will detect when moisture is present. It is recommended that this detector (Black & White wires) be connected in series to an alarm device or the motor starter coil to alert the operator that a moisture detect has occurred. In the event of a moisture detect, check the individual moisture sensor probe leads for continuity and the junction box/control box for moisture content. This situation may induce a false signal in the moisture detecting circuit. Normal resistance between leads is 33,000 OHMS indicating normal connection. When the resistance drops well below that, then moisture is present and the pump seals should be serviced. **IF A MOISTURE DETECT HAS OCCURRED, SCHEDULE MAINTENANCE AS SOON AS POSSIBLE.** On three phase double seal models connect the **single white wire** to the moisture detecting circuit terminal S1 and the other terminal S2 of the panel circuit should be wired or jumpered to ground (wire to be supplied by installer in field, not provided).

THREE PHASE INSTALLATION: Check proper rotation. Improper motor rotation can result in poor pump performance and pump failure. The power leads are the red, black and white wires. There should be approximately an equal ohm resistance between these leads. The blue-green color lead is the ground wire. Once the leads are connected to the power terminals then you are ready to check the rotation. Momentarily apply power to the pump with it laying on its side and impeller clear from obstruction. Observe "kickback" as it should always be in counter-clockwise direction as viewed from top of the motor housing or opposite to impeller rotation. If rotation is incorrect when power is supplied, then reverse two of the leads at the power terminal and try again. This should correct the rotation. Once pump is in operation the amperage of each leg of the power connection should be checked and recorded on the start up sheet. They should be close to the same value for each leg (within 5% of the average leg to leg value). If they are not, try advancing the connections to balance the readings, but do not lose proper rotation.

USER GUIDE

SERVICE Lubrication: Anytime the pump is removed from operation, the cooling oil in the motor housing should be checked visually for oil level and contamination.

Checking Oil: To check oil in the motor housing, set pump upright. Remove plug from motor housing. With a flashlight, visually inspect the oil in the motor housing to make sure it is clean and clear, light amber in color and free from suspended particles. Milky white oil indicates the presence of water. Oil level should be just above the motor when pump is in the vertical position.

Testing Oil: Place pump on it's side, remove plug from motor housing and drain oil into a clean, dry container. Check oil for contamination using an oil tester with a range to 30 Kilovolts breakdown. If oil is found to be clean and uncontaminated (measuring above 15KV. Breakdown), refill the motor housing. (See Replacing Oil below) If oil is found to be dirty or contaminated, the pump must be carefully inspected for leaks at the shaft seals, cord assemblies, O-rings, and plugs before refilling with oil. To locate the leak, perform a pressure test. After leak is repaired, dispose of old oil properly, and refill with new oil.

Replacing Motor Housing Oil: Drain all oil from motor housing and dispose of properly per local and environmental standards. Set unit upright and refill with new cooling oil. Fill to just above motor (see Table 2, Item #16) as an air space must remain in the top of the motor housing to compensate for oil expansion. Apply pipe thread compound to threads on plug and insert and tighten into housing.

Replacing Seal Chamber Oil: Drain all oil from seal chamber and dispose of properly per local and environmental standards. Set unit on its side, with plug upward, and refill with new oil. (approximately 13oz) Apply pipe thread compound to threads on plug and insert and tighten into housing.

WARNING! Do not overfill oil. Over filling of oil can create excessive and dangerous hydraulic pressure which can destroy the pump and create a hazard. Overfilling oil voids warranty.

DIELECTRIC COOLING OIL : BP – Enerpar SE100; Conoco – Pale Paraffin 22; Mobile – D.T.E. Oil Light; G&G Oil – Circulating 22; Imperial Oil – Voltesso-35; Shell Canada – Transformer-10; Texaco – Diala-oil-AX; Woxo – Premium 100, Shell 2210.

Pressure Test for pumps that have been disassembled.: If the pump has been disassembled, the oil should be drained before a pressure test. Remove plug from motor housing. Apply pipe sealant to a pressure gauge assembly and tighten into hole. Pressurize motor housing to 10 P.S.I. Use soap solution around the sealed areas and inspect joints for “air bubbles”. If, after five minutes, the pressure is holding constant, and no signs of leaks are observed, slowly bleed the pressure and remove the gauge assembly. Replace oil. If the pressure does not hold, then the leak must be located and repaired.

CAUTION! Pressure builds up extremely fast. Too much pressure will damage seal.

Impeller face Clearance: Proper Face clearance should come correctly preset from then factory. However, if the pump is serviced or not performing correctly, the face clearance should be checked. To obtain proper pumping performance the face clearance between the impeller (item 37) and the volute (item 39) should not exceed .03”. Shim gaskets (item 38) can be added or removed to adjust the face clearance. The gasket is approximately .01” thick.



TROUBLE SHOOTING

CAUTION! Always disconnect the pump from the electrical power source before handling.

If the system fails to operate properly, carefully read instructions and perform maintenance recommendations.

If operating problems persist, the following chart may be of assistance in identifying and correcting them:

MATCH "CAUSE" NUMBER WITH CORRELATING "CORRECTION" NUMBER.

NOTE: Not all problems and corrections will apply to each pump model.

PROBLEM	CAUSE	CORRECTION
Pump will not run.	1. Poor electrical connection, blown fuse, tripped breaker or other interruption of power, improper power supply. 2. Motor or switch inoperative (to isolate cause, go to manual operation of pump). 2a. Float movement restricted. 2b. Switch will not activate pump or is defective 3. Insufficient liquid level.	1. Check all electrical connections for security. Have electrician measure current in motor leads. If current is within +or-20% of locked rotor amps, impeller is probably locked. If current is 0, overload may be tripped. Remove power, allow pump to cool, then re-check current. 2a. Reposition pump or clean basin as required to provide adequate clearance for float. 2b. Disconnect level control. Set ohmmeter for a low range, such as 100 ohms full scale and connect to level control manually and check to see that ohmmeter shows zero ohms for closed switch and full scale for open switch. (Float Switch) 3. Make sure liquid level is at least equal to suggested turn-on point. 4. Re-check all sizing calculations to determine proper pump size.
Pump will not turn off.	2a. Float movement restricted. 2b. Switch will not activate pump or is defective 4. Excessive inflow or pump not properly sized for application. 9. Pump may be air locked. 14. H-O-A switch on panel is in "Hand" position.	5. Check discharge line for restrictions, including ice if line passes through or into cold areas. 6. Remove and examine check valve for proper installation and freedom of operation. 7. Open valve. 8. Check impeller for freedom of operation and condition. Clean impeller and inlet of any obstruction. 9. Loosen union slightly to allow trapped air to escape. Verify that turn-off level of switch is set so that the suction is always flooded. Clean vent hole. 10. Remove & examine for damage. Replace pump stator if required.
Pump hums but does not run	1. Incorrect voltage 8. Impeller clogged, loose on shaft, worn or damaged, inlet plugged.	11. Repair fixtures as required to eliminate leakage 12. Check pump temperature limits & fluid temperature. 13. replace portion of discharge pipe with flexible connector.
Pump delivers insufficient capacity	1. Incorrect voltage 4. Excessive inflow or pump not properly sized for application. 5. Discharge restricted. 6. Check valve stuck closed or installed backwards. 7. Shut-off valve closed. 8. Impeller clogged, loose on shaft, worn or damaged, inlet plugged. 9. Pump may be air locked. 10. Pump stator damaged / torn. 16. Improper impeller face clearance 17. Three Phase units rotating incorrectly	14. Turn to automatic position. 15. Check for leaks around basin inlet and outlets. 16. Check impeller to volute face clearance (See Service) 17. THREE PHASE UNITS: Check Proper Rotation
Pump cycles too frequently or runs periodically when fixtures are not in use.	6. Check valve stuck closed or installed backwards. 11. Fixtures are leaking 15. Ground water is entering basin.	
Pump shuts off and turns on independent of switch, (trips thermal overload protector). CAUTION: Pump may start unexpectedly. Disconnect power supply. High AMPS	1. Incorrect voltage 4. Excessive inflow or pump not properly sized for application. 8. Impeller clogged, loose on shaft, worn or damaged, inlet plugged. 12. Excessive water temperature 16. Improper impeller face clearance	
Pump operates noisily or vibrates excessively.	4. Operating at too high / low of pressure 5. Discharge restricted. 8. Impeller broken or clogged. 13. Piping attachments to building structure too rigid or too loose. 17. Three Phase units rotating incorrectly	

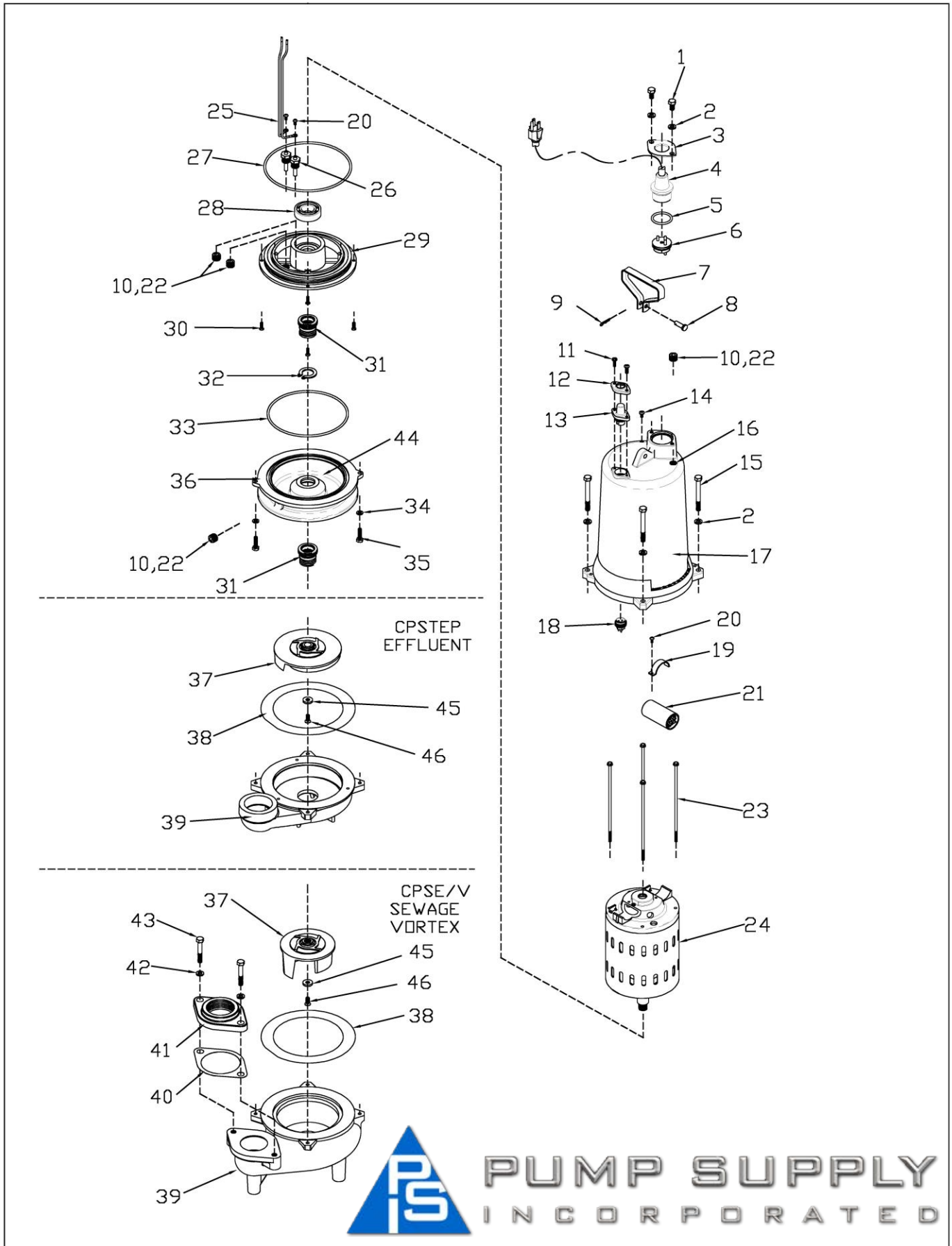

#	PART NUMBER	Q	DOUBLE SEAL	SINGLE SEAL
1	14-0007-1000 CAPSCREW	2	•	•
2	16-0002-1000 LOCKWASHER	6	•	•
+ 3	6-0005-1000 CORD PLATE	1	•	•
+ 4	SEE TABLE 1 POWER CORD	1	•	•
5	11-1003-2030 O-RING	1	•	•
6	SEE TABLE 1 ELECTRICAL TERMINAL	1	•	•
7	10-0003-1001 HANDLE	1	•	•
8	19-0003-1000 HANDLE PIN	1	•	•
9	19-0003-1001 HOLD PIN	1	•	•
10	20-0000-1000 PIPE PLUG	3		•
10	20-0000-1000 PIPE PLUG	2	•	
11	14-0002-1004 SCREW	2	•	3PH
◇ 12	6-0006-1000 CORD PLATE	1	•	3PH
◇ 13	20-0001-0000 SENSOR PLUG	1	•	3PH
◇ 13	SEE TABLE 1 SENSOR CORD	1	•	3PH
14	14-0002-1004 SCREW	1	•	•
15	14-0008-1000 CAPSCREW	4	•	•
15	14-0011-1000 CAPSCREW	4		•
16	21-0001-0000 OIL	TABLE 2	•	•
17	4-0004-3000 MOTOR HOUSING	1	•	•
18	22-0005-2020 ELEC. TERMINAL	1	•	•
* 19	SEE TABLE 2 CAPACITOR CLAMP	1	•	•
* 20	14-0009-1000 SCREW	2		•
* 20	14-0009-1000 SCREW	4	•	
* 21	SEE TABLE 2 START CAPACITOR	1	•	•
22	- PERMATAX 2C	-	•	•
* 23	14-0009-0001 1/2HP SCREW	4	•	•
* 23	14-0009-0000 1-2HP SCREW	4	•	•
* 24	SEE TABLE 2 MOTOR	1	•	•
25	22-0006-0000 SENSOR WIRE	2	•	
26	22-0003-0000 MOISTURE SENSOR	2	•	
27	11-1001-2030 O-RING	1	•	•

#	PART NUMBER	Q	DOUBLE SEAL	SINGLE SEAL
* 28	15-0002-0000 BEARING	1	•	•
29	6-0003-3000 BEARING/SEAL PLATE	1	•	•
30	14-0005-1000 SCREW	4	•	•
31	7-0002-2101 MECHANICAL SEAL	1		•
31	7-0002-2101 MECHANICAL SEAL	2	•	
32	19-0005-0000 RETAINER RING	1	•	
33	11-1002-2030 O-RING	1	•	
34	14-0006-1000 LOCKWASHER	5	•	
34	14-0006-1000 LOCKWASHER	3		•
35	16-0001-1000 CAPSCREW	5	•	
35	16-0001-1000 CAPSCREW	3		•
36	6-0004-3000 SEAL PLATE	1	•	
37	SEE TABLE 2 IMPELLER	1	•	
38	11-2001-1520 SHIM GASKET	A/R	•	•
39	2-0003-3003 EFF. VOLUTE	1	•	•
39	2-0006-3002 SEWAGE VOLUTE	1	•	•
39	2- -3002 VORTEX VOLUTE	1	•	•
40	11-2002-1510 FLANGE GASKET	1	•	•
41	15-0100-3000 2" FLANGE	1	•	•
41	15-0101-3000 3" FLANGE	1	•	•
42	16-0005-1000 LOCKWASHER	2	•	•
43	14-0012-1000 2" FLG CAPSCREW	2	•	•
43	14-0013-1000 3" FLG CAPSCREW	2	•	•
44	21-0001-0000 OIL	15.2oz	•	
45	16-0000-1000 RETAINER WASHER	1	•	•
46	14-0004-1000 SCREW	1	•	•

+ WHEN ORDERING ITEM 4; ITEM 3 IS INCLUDED
 ◇ WHEN ORDERING ITEM 13; ITEM 12 IS INCLUDED
 * WHEN ORDERING ITEM 24; ITEM 19,20,21,23 AND 28 ARE INCLUDED

POWER & CONTROL CABLES				3PH&DBLE SEAL ONLY	460 V
CABLE LENGTH	WIRES	ITEM 4	ITEM 6	ITEM 13	ITEM 4
20'	3	9-0020-1402	22-0002-2020	9-0021-1604	
50'	3	9-0050-1405	22-0002-2020	9-0051-1601	
20'	4	9-0021-1405	22-0003-2020	9-0021-1604	9-0020-1406
50'	4	9-0051-1405	22-0003-2020	9-0051-1601	9-0050-1406

MODELS			SINGLE SEAL	DOUBLE SEAL	EFFLUENT	SEWAGE	VORTEX		
EFFLUENT	SEWAGE	ITEM 16	ITEM 19	ITEM 21	ITEM 24	ITEM 24	ITEM 37	ITEM 37	ITEM 37
CPSTEP 512	CPSE/V512	70 OZ.	19-0004-0000	22-0004-0040	5-0004-0100	5-0004-0000	3-0008-3003	3-0004-3002	3-0022-3012
CPFSTEPF 512	CPSEF1/2HP		19-0004-0000	22-0004-0040	5-0004-0100	5-0004-0000	3-0013-3003	3.3" Dia	3.5" Dia
CPSTEP 522	CPSE/V522		19-0004-0000	22-0004-0020	5-0004-2100	5-0004-2000	3-0008-3003	3-0004-3002	3-0022-3012
CPFSTEPF522			19-0004-0000	22-0004-0020	5-0004-2100	5-0004-2000	3-0013-3003		3.5" Dia
CPSTEPF 1022	CPSE/V1022	68 OZ.	19-0004-0000	22-0004-0028	5-0005-2100	5-0005-2000	3-0010-3003	3-0005-3002	3-0022-3012
CPFSTEP 1022	CPSEF 1HP	66 OZ.	19-0006-0000	22-0004-0060	5-0007-2100	5-0007-2000	3-0009-3003	3.6" Dia	4.0" Dia
CPSTEP 1522	CPSE/V1522	66 OZ.	19-0006-0000	22-0004-0060	5-0007-2100	5-0007-2000	3-0011-3003	3-0006-3002	4.25" Dia
	CPSE/V2022	66 OZ.	19-0006-0000	22-0004-0060	5-0007-2100	5-0007-2000			4.5" Dia
CPSTEP 2022	CPSEVH2022	66 OZ.	19-0006-0000	22-0004-0060	5-0007-2100	5-0007-2000	3-0012-3003	3-0007-3002	5.0" Dia
CPSTEP 532/42	CPSE/V532/42	70 OZ.			5-0004-2103	5-0004-2003	3-0008-3003	3-0004-3002	3-0022-3012
CPFSTEPF532/42						5-0004-2103	5-0004-2003	3-0013-3003	3.5" Dia
CPSTEPF1032/42	CPSE/V1032/42	68 OZ.			5-0005-2103	5-0005-2003	3-0010-3003	3-0005-3002	3-0022-3012
CPSTEP 1032/42	CPSEF 2HP	66 OZ.			5-0007-2100	5-0007-2000	3-0009-3003	3.9" Dia	4.0" Dia
CPSTEP 1532/42	CPSE/V1532/42	66 OZ.			5-0007-2100	5-0007-2000	3-0011-3003	3-0006-3002	4.25" Dia
CPSTEP 2032/42	CPSE/V2032/42	66 OZ.			5-0007-2100	5-0007-2000	3-0012-3003	3-0007-3002	4.5" Dia
	CPSEVH2032/42	66 OZ.			5-0007-2100	5-0007-2000			5.0" Dia

Specifications

DISCHARGE.....CPSTEP 2"; CPSE/V...2"or3" NPT.
 SOLIDS HANDLING.....Effluent ¾" Sewage 2"
 LIQUID TEMP.....140 DEG. F. INTERMITTENT
 MOTOR HOUSING.....Cast Iron
 VOLUTE.....Cast Iron
 SEAL PLATE.....Cast Iron
 IMPELLER..... Cast Iron
 SHAFT.....416 Stainless Steel
 MOTOR..... (1 PHASE) 3450 RPM. 60 Hz
 Includes Overload Protection In The Motor
 Oil Filled, Class F Insulation
 PSC
 (3 PHASE) 3450 RPM 60 Hz
 Requires Overload Protection In Control Panel
 OPTIONAL SEAL FAILURE.....20' Length Standard
 UL / CSA (SJTW) 16/3 (.330OD)

SHAFT SEAL -(SINGLE SEAL)
 Carbon - Ceramic
 Buna-N-Elastomer
 300 Series Stainless Steel - Hardware
 SHAFT SEAL -(DOUBLE SEAL)
 Tandem Double Mechanical
 Upper & Lower Carbon - Ceramic
 Buna-N-Elastomer
 300 Series Stainless Steel - Hardware
 BEARING (UPPER & LOWER)
 Single Row, Ball. Oil Lubricated
 HARDWARE.....316 Series Stainless Steel
 O-RINGS.....Buna-N
 CORD.....20' Length Standard
 UL / CSA (SJOW) 14/3 (.375OD)
 UL / CSA (SO) 14 ga. (.60 OD) 460Volt

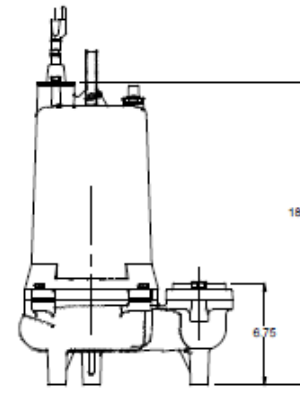
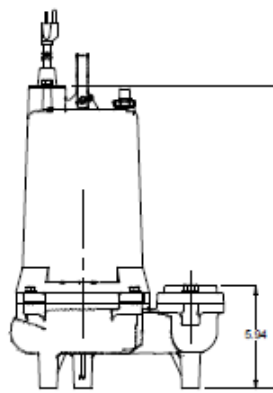
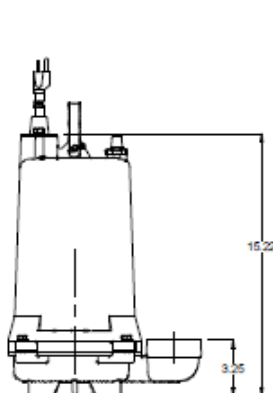
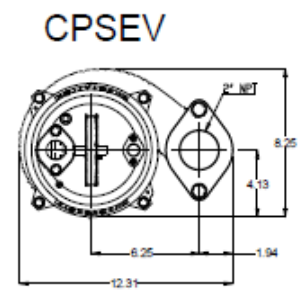
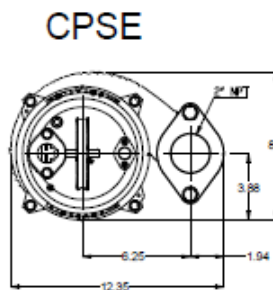
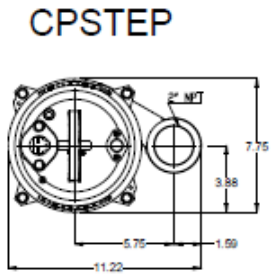

Champion Pump Company

Limited 3 Year Warranty

We warrant that products of our manufacture will be free of defects in material and workmanship under normal use and service for 3 years from the date of purchase when installed and maintained in accordance with our instructions.

This warranty gives you specific legal rights, and there may also be other rights which vary from state to state. In the event the product is covered by the Federal Consumer Product Warranties Law (1) the duration of any implied warranties associated with the product by virtue of said law is limited to the same duration as stated herein, (2) this warranty is a LIMITED WARRANTY, and (3) no claims of any nature whatsoever shall be made against us, until the ultimate consumer, his successor, or assigns, notifies us in writing of the defect, and delivers the product and/or defective part(s) freight prepaid to our factory or nearest authorized service station. Some states do not allow limitations on how long an implied warranty lasts, so the above limitation may not apply. **THE SOLE AND EXCLUSIVE REMEDY FOR BREACH OF ANY AND ALL WARRANTIES WITH RESPECT TO ANY PRODUCT SHALL BE TO REPLACE OR REPAIR AT OUR ELECTION, F.O.B. POINT OF MANUFACTURE OR AUTHORIZED REPAIR STATION, SUCH PRODUCTS AND/OR PARTS AS PROVEN DEFECTIVE. THERE SHALL BE NO FURTHER LIABILITY, WHETHER BASED ON WARRANTY, NEGLIGENCE OR OTHERWISE.** Unless expressly stated otherwise, guarantees in the nature of performance specifications furnished in addition to the foregoing material and workmanship warranties on a product manufactured by us, if any, are subject to laboratory tests corrected for field performance. Any additional guarantees, in the nature of performance specifications must be in writing and such writing must be signed by our authorized representative. Due to inaccuracies in field testing if a conflict arises between the results of field testing conducted by or for user, and laboratory tests corrected for field performance, the latter shall control. **RECOMMENDATIONS FOR SPECIAL APPLICATIONS OR THOSE RESULTING FROM SYSTEMS ANALYSES AND EVALUATIONS WE CONDUCT WILL BE BASED ON OUR BEST AVAILABLE EXPERIENCE AND PUBLISHED INDUSTRY INFORMATION. SUCH RECOMMENDATIONS DO NOT CONSTITUTE A WARRANTY OF SATISFACTORY PERFORMANCE AND NO SUCH WARRANTY IS GIVEN.**

This warranty shall not apply when damage is caused by (a) improper installation, (b) improper voltage (c) lightning (d) excessive sand or other abrasive material (e) scale or corrosion build-up due to excessive chemical content. Any modification of the original equipment will also void the warranty. We will not be responsible for loss, damage or labor cost due to interruption of service caused by defective parts. Neither will we accept charges incurred by others without our prior written approval.

This warranty is void if our inspection reveals the product was used in a manner inconsistent with normal industry practice and/or our specific recommendations. The purchaser is responsible for communication of all necessary information regarding the application and use of the product. **UNDER NO CIRCUMSTANCES WILL WE BE RESPONSIBLE FOR ANY OTHER DIRECT OR CONSEQUENTIAL DAMAGES, INCLUDING BUT NOT LIMITED TO LOST PROFITS, LOST INCOME, LABOR CHARGES, DELAYS IN PRODUCTION, IDLE PRODUCTION, WHICH DAMAGES ARE CAUSED BY ANY DEFECTS IN MATERIAL AND/OR WORKMANSHIP AND/OR DAMAGE OR DELAYS IN SHIPMENT. THIS WARRANTY IS EXPRESSLY IN LIEU OF ANY OTHER EXPRESS OR IMPLIED WARRANTY, INCLUDING ANY WARRANTY OF MERCHANTABILITY OR FITNESS FOR A PARTICULAR PURPOSE.**

No rights extended under this warranty shall be assigned to any other person, whether by operation of law or otherwise, without our prior written approval.

Champion Pump Company, Inc.
P.O. Box 528
Ashland, Ohio 44805
PH: 419-281-4500 FAX: 419-616-1100

Start-Up Report / Warranty Registration

Please fill out the following questions as completely and accurate as possible. Please mail to Champion Pump Company, Inc. – P. O. Box 528 – Ashland, OH 44805.

REPORTS THAT ARE NOT RETURNED CAN DELAY OR VOID WARRANTY.

Pump Owner's

Name: _____

Address: _____

Location of installation: _____

Phone: _____

Purchased from: _____

Pump Model _____ Serial # _____ Date Code: _____

Date Installed: _____

Does impeller turn freely by hand? YES _____ NO _____

Condition of cord jacket? Good _____ Fair _____ Poor _____

Was equipment stored? _____ How long? _____

Liquid being pumped _____

Debris in bottom of station? _____ Was debris removed in your presence? _____

Discharge pipe size? _____ Length of pipe? _____ Static lift? _____

Does station appear to operate at the proper rate? _____ Pump down time? _____

Voltage At Wiring Terminal L1-L2 _____ L2-L3 _____ L1-L3 _____

Run Amps L1 _____ L2 _____ L3 _____

3 Phase Models – Check Proper Rotation? Yes / NO

Difficulties during start up:

I certify this report to be accurate (start up person) _____

Employed by _____ Date: _____

