

Champion Pump



PUMP SUPPLY
INCORPORATED

SUBMERSIBLE SOLIDS HANDLING PUMP

Series: CPSE

1.5 & 2 HP / 1750 RPM

Discharge: 3"

Spherical solids handling: 2½"



DISCHARGE

3" NPT female, vertical, bolt on flange.

LIQUID TEMPERATURE

104 °F (40 °C).

VOLUTE

Cast iron ASTM A-48 class 30.

MOTOR HOUSING

Cast iron ASTM A-48 class 30.

SEAL PLATE

Cast iron ASTM A-48 class 30.

IMPELLER

Design: 2 vane, open, with vanes on back side.

Material: cast iron ASTM A-48 class 30.

SHAFT

416 series stainless steel.

HARDWARE

300 series stainless steel.

SQUARE RINGS

Buna-N.

PAINT

Air dry enamel, water based.

SEAL

Design: inboard, single mechanical, oil filled chamber.

Material: silicon carbide, Buna-N elastomer and stainless steel hardware.

CORD ENTRY

25 ft of neoprene cord SJO 14/3, sealed against moisture.

BEARINGS

Upper: ball, single row, oil lubricated, for radial load.

Lower: ball, single row, oil lubricated, for radial and thrust load.

MOTOR

Single phase: NEMA L, permanent split capacitor, 200/230 volts, 60 Hz, 1750 RPM, oil filled, with overload protection in motor.

Three phase: NEMA B, 200/230 & 460 volts, 60 Hz, 1750 RPM, oil filled. Requires overload protection to be included in control panel.

OPTIONAL EQUIPMENT

Additional cord.

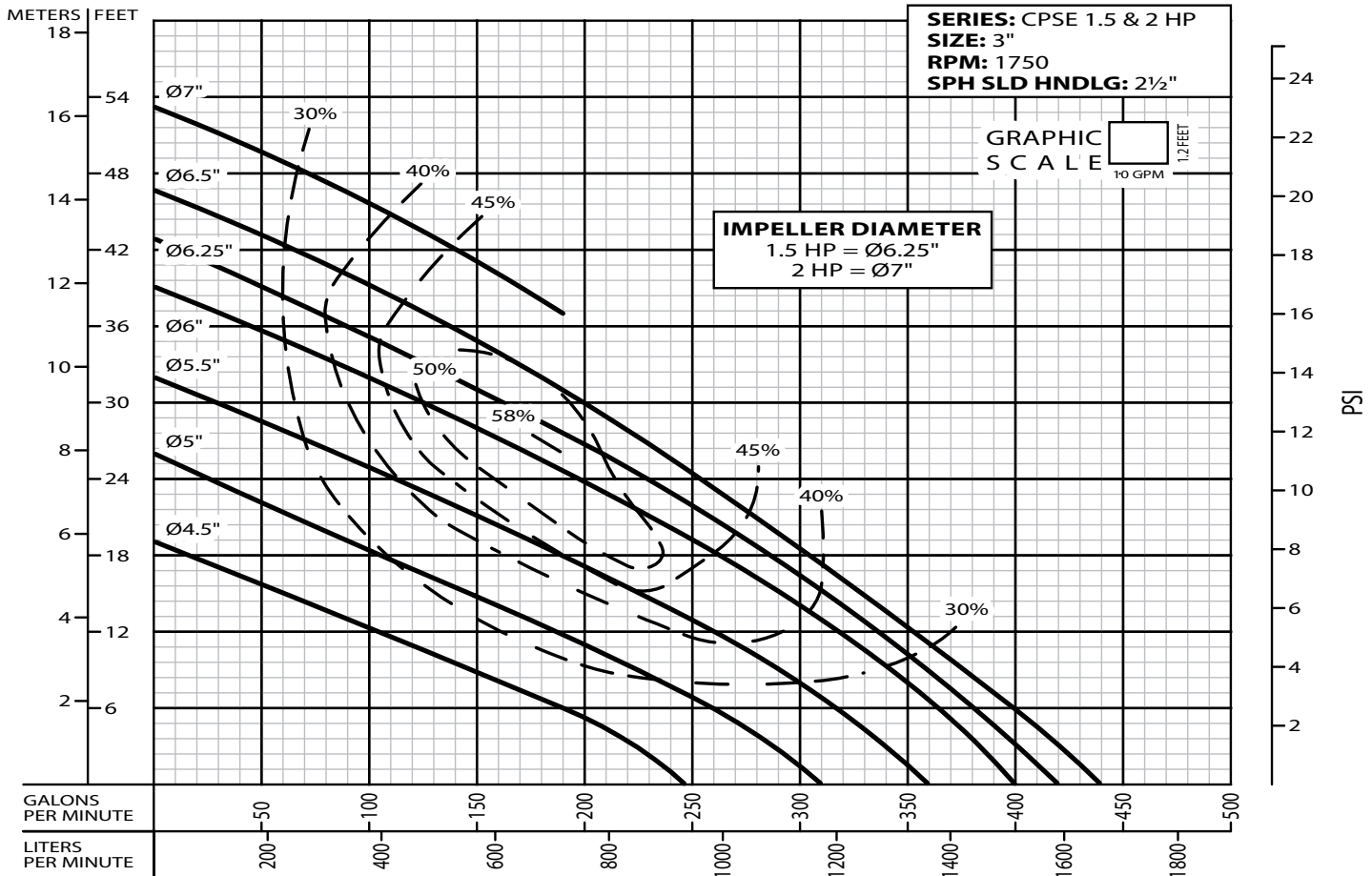
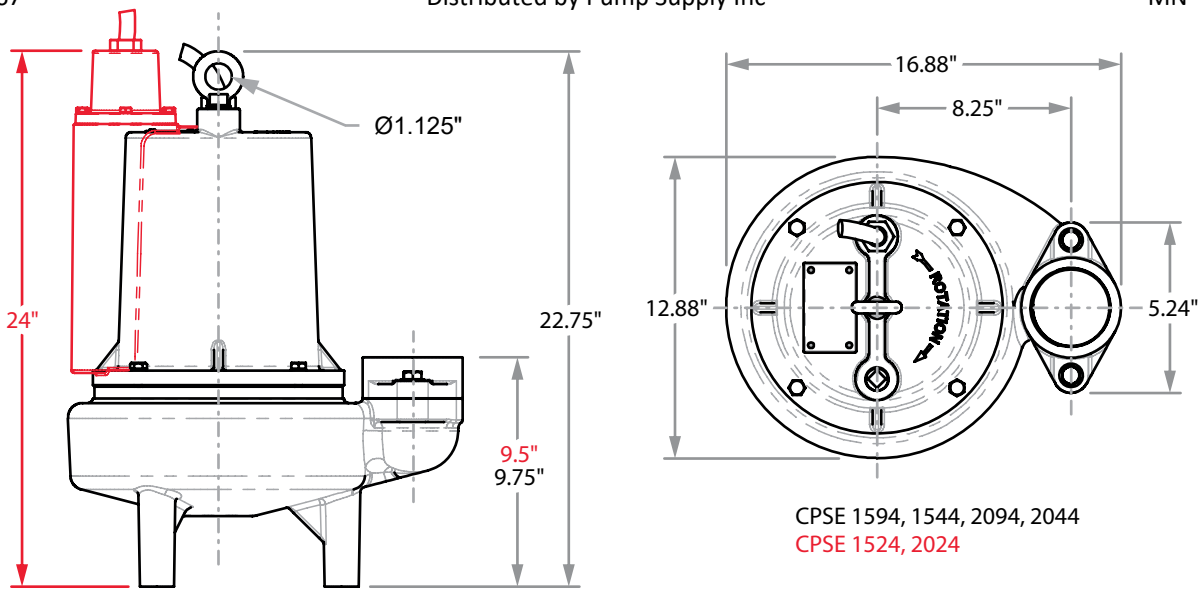

MODEL	HP	VOLTS	PHASE	RPM	MAX AMPS	LOCKED ROTOR AMPS	NEMA CODE	CORD SIZE	CORD TYPE	CORD LENGTH	WEIGHT
CPSE1524	1.5	200/230	1	1750	16	23	B	10/3	SJO	25'	225
CPSE1594	1.5	200/230	3	1750	11.6	36	H/L	10/4	SJO	25'	207
CPSE1544	1.5	460	3	1750	5.8	17.5	L	10/4	SJO	25'	207
CPSE2024	2	200/230	1	1750	19	29	B	10/3	SJO	25'	229
CPSE2094	2	200/230	3	1750	14	50.8	J/M	10/4	SJO	25'	207
CPSE2044	2	460	3	1750	7	25.4	M	10/4	SJO	25'	207

IMPORTANT!

1. Never use this pump to handle explosive liquids. 2. This pump is not approved to be used in swimming pools, recreational installations or any application where human contact may be common. 3. Pump may be operated "dry" for extended periods without damage to motor &/or seals. 4. Testing is performed with water specific gravity of 1.0 @ 68 °F (20 °C); other fluids may vary performance.