

Champion Pump



PUMP SUPPLY INCORPORATED

SUBMERSIBLE SOLIDS HANDLING PUMP

Series: CP6NC
30-60 HP / 1750 RPM
Discharge: 6"
Spherical solids handling: 3"



DISCHARGE

6", 125 lb, flange horizontal.

LIQUID TEMPERATURE

104°F (40°C) continuous.

VOLUTE

Cast iron ASTM A-48 class 30.

WEARING RING

Bronze.

MOTOR HOUSING

Cast iron ASTM A-48 class 30.

SEAL PLATE

Cast iron ASTM A-48 class 30.

IMPELLER

Design: 3 vanes, closed, with vanes on back side.

Material: cast iron ASTM A-48 class 30.

SHAFT

416 series stainless steel.

SQUARE RINGS

Buna-N.

PAINT

Air dry enamel, water based.

DIAPHRAGM

Buna-N.

HARDWARE

300 series stainless steel.

SEAL

Design: double, mechanical, oil filled chamber.

Material: silicon carbide outboard seal, carbon ceramic inboard seal, Buna-N elastomer and stainless steel hardware.

CORD ENTRY

25 ft of neoprene cord 2/4 G, sealed against moisture.

BEARINGS

Upper: ball, single row, oil lubricated, for radial load.

Lower: ball, single row, oil lubricated, for radial and thrust load.

MOTOR

NEMA B, three phase, 200/230 & 460 volts, 60 Hz, 1750 RPM, oil filled. Requires overload protection to be included in control panel.

MOISTURE SENSOR

Normally open (N/O) included.

TEMPERATURE SENSOR

Normally closed (N/C) included.

OPTIONAL EQUIPMENT

Impeller trimming, additional cord, tungsten carbide seal, slide rail coupling (SRC-6).

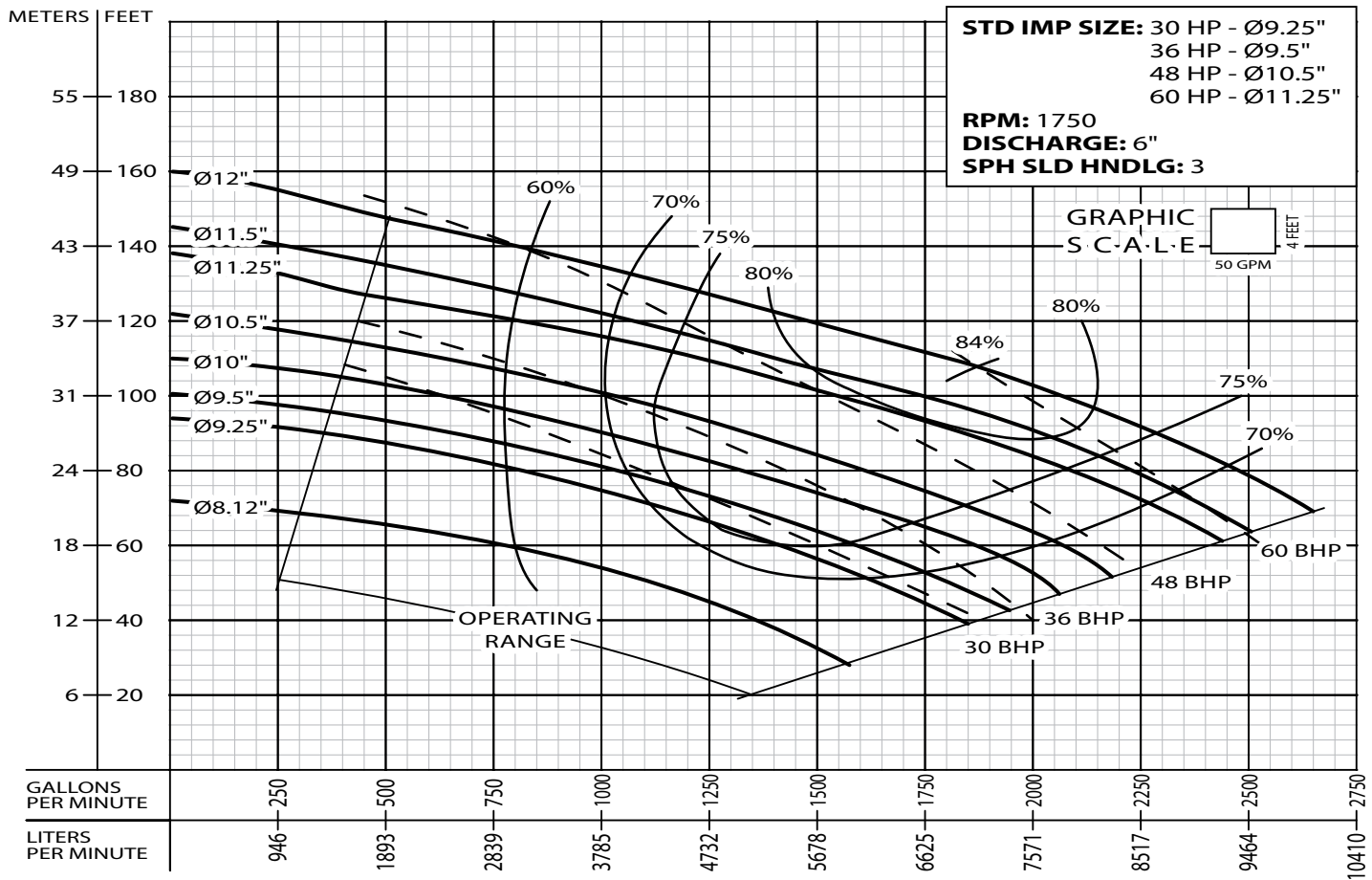
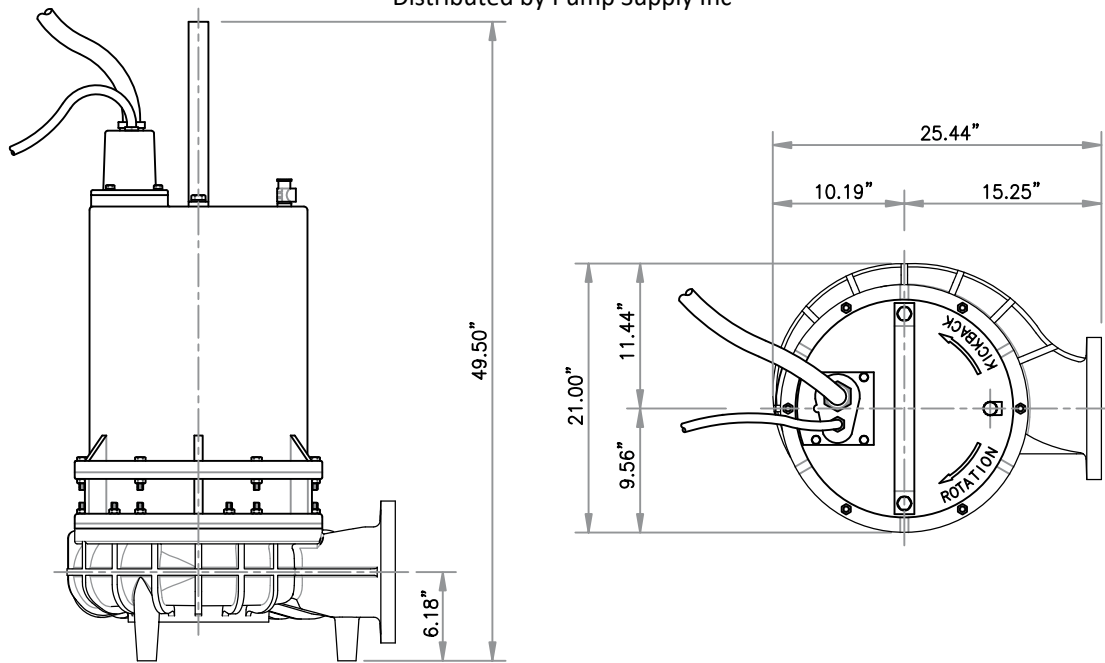

MODEL	HP	VOLTS	PHASE	RPM	MAX AMPS	LOCKED ROTOR AMPS	NEMA CODE	CORD SIZE	CORD TYPE	CORD LENGTH	WEIGHT
CP6NC30034H	30	230	3	1750	76	364	F	2/3	G	25'	957
CP6NC30044H	30	460	3	1750	38	182	F	2/3	G	25'	957
CP6NC36034H	36	230	3	1750	90	434	E	2/3	G	25'	963
CP6NC36044H	36	460	3	1750	45	217	F	2/3	G	25'	963
CP6NC48044H	48	460	3	1750	65	290	E	2/3	G	25'	974
CP6NC60044H	60	460	3	1750	78	363	E	2/3	G	25'	1005

IMPORTANT!

1. Never use this pump to handle explosive liquids. 2. This pump is not approved to be used in swimming pools, recreational installations or any application where human contact may be common. 3. Pump may be operated "dry" for extended periods without damage to motor &/or seals. 4. Testing is performed with water specific gravity of 1.0 @ 68 °F (20 °C); other fluids may vary performance.