

Champion Pump



PUMP SUPPLY
INCORPORATED

SUBMERSIBLE SOLIDS HANDLING PUMP

Series: CP6NC
9-30 HP / 1150 RPM
Discharge: 6"
Spherical solids handling: 3"



DISCHARGE

6", 125 lb, flange horizontal.

LIQUID TEMPERATURE

104 °F (40 °C) continuous.

VOLUTE

Cast iron ASTM A-48 class 30.

WEARING RING

Bronze.

MOTOR HOUSING

Cast iron ASTM A-48 class 30.

SEAL PLATE

Cast iron ASTM A-48 class 30.

IMPELLER

Design: 1 vane, closed, with vanes on back side.

Material: cast iron ASTM A-48 class 30.

SHAFT

416 class stainless steel.

SQUARE RINGS

Buna-N.

PAINT

Air dry enamel, water based.

DIAPHRAGM

Buna-N.

HARDWARE

300 series stainless steel.

SEAL

Design: double, mechanical, oil filled chamber.

Material: silicon carbide outboard seal, carbon ceramic inboard seal, Buna-N elastomer and stainless steel hardware.

CORD ENTRY

25 ft of neoprene cord 2/4 G, sealed against moisture.

BEARINGS

Upper: ball, single row, oil lubricated, for radial load.

Lower: ball, single row, oil lubricated, for radial and thrust load.

MOTOR

NEMA B, three phase, 230 & 460 volts, 60 Hz, 1150 RPM, oil filled. Requires overload protection to be included in control panel.

MOISTURE SENSOR

Normally open (N/O) included.

TEMPERATURE SENSOR

Normally closed (N/C) included.

OPTIONAL EQUIPMENT

Impeller trimming, additional cord, tungsten carbide seal, slide rail coupling.

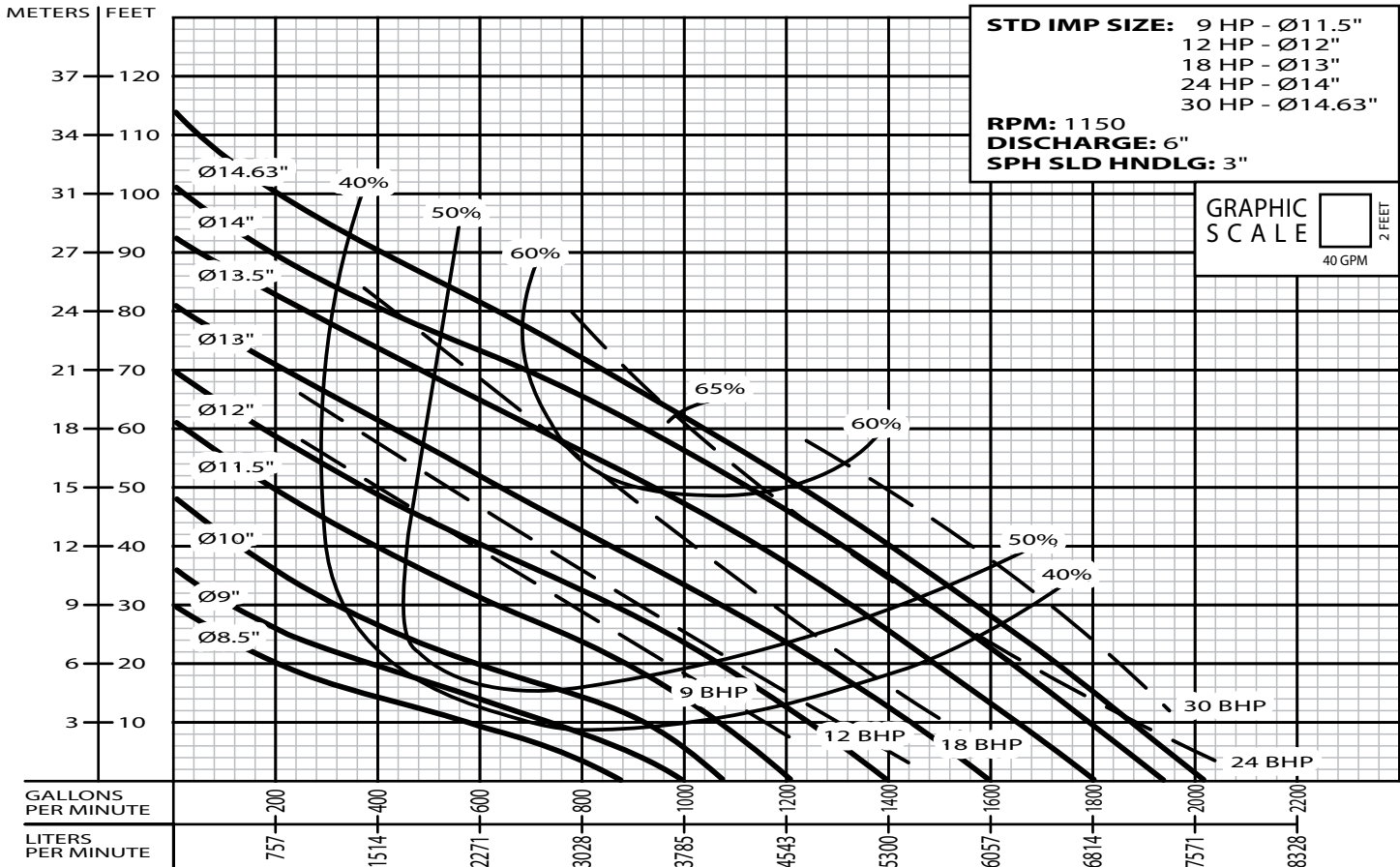
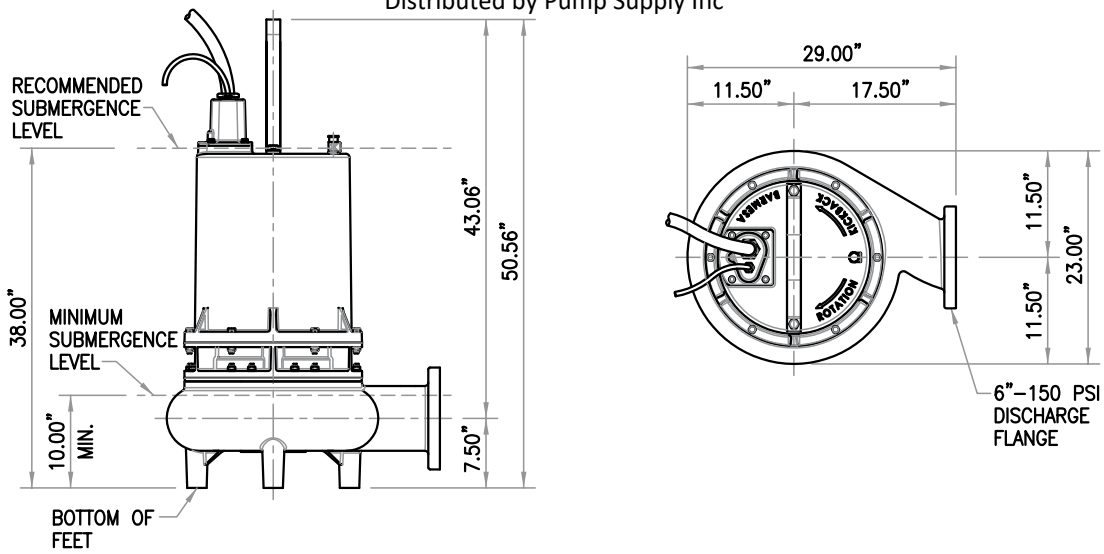

MODEL	HP	VOLTS	PHASE	RPM	MAX AMPS	LOCKED ROTOR AMPS	NEMA CODE	CORD SIZE	CORD TYPE	CORD LENGTH	WEIGHT
CP6NC9096	9	230	3	1150	26	162	F	2/3	G	25'	897
CP6NC9046	9	460	3	1150	13	81	J	2/3	G	25'	897
CP6NC12096	12	230	3	1150	36	162	D	2/3	G	25'	902
CP6NC12046	12	460	3	1150	18	81	F	2/3	G	25'	902
CP6NC18096	18	230	3	1150	50	232	C	2/3	G	25'	917
CP6NC18046	18	460	3	1150	25	116	F	2/3	G	25'	917
CP6NC24096	24	230	3	1150	64	290	C	2/3	G	25'	961
CP6NC24046	24	460	3	1150	32	145	E	2/3	G	25'	961
CP6NC30096	30	230	3	1150	82	364	C	2/3	G	25'	1008
CP6NC30046	30	460	3	1150	41	182	E	2/3	G	25'	1008

IMPORTANT!

1. Never use this pump to handle explosive liquids. 2. This pump is not approved to be used in swimming pools, recreational installations or any application where human contact may be common. 3. Pump may be operated "dry" for extended periods without damage to motor &/or seals. 4. Testing is performed with water specific gravity of 1.0 @ 68 °F (20 °C); other fluids may vary performance.