

Wilfley

**Centrifugal
Acid
Pump**

Operating Handbook

Model AG

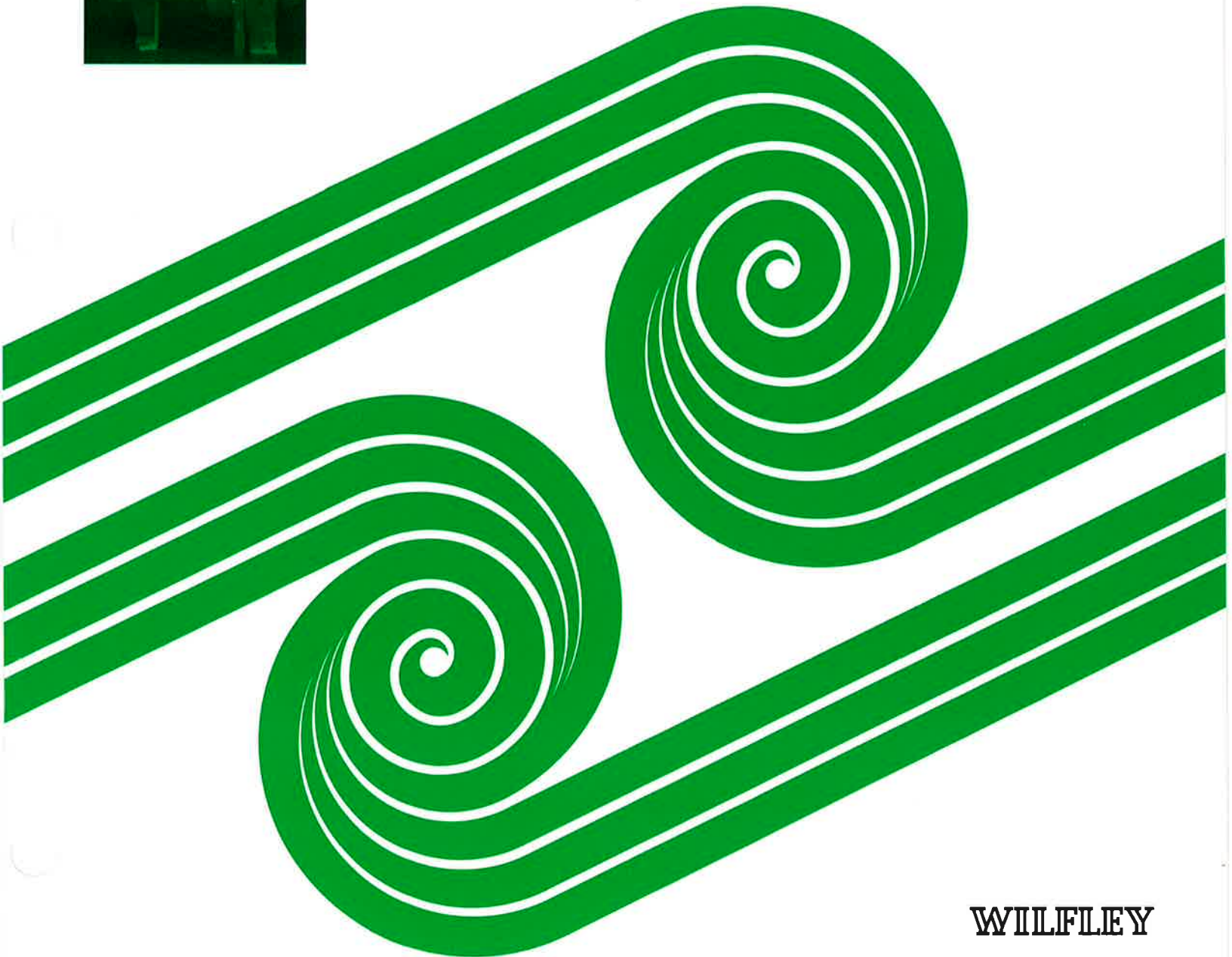
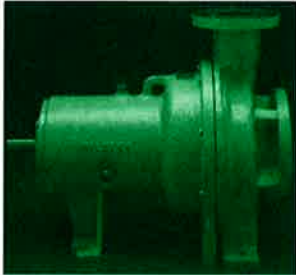

WILFLEY



Model AG Operating Handbook

Illinois Location:

(847) 841-7867

860 Church Rd Elgin, IL 60123

Minnesota Location:

(651) 758-7867

330 Mill Bay South Suite 1511 Afton, MN 55001

Table of Contents

Safety Precautions	2
General Installation	3
Operating and General Servicing Recommendations	4
General Repair and Part Replacement Instructions	5
Pump Assembly Instructions	6
Final Assembly-Metal Pumps	8
Final Assembly-Non-Metallic Pumps	10
Frame 1 Metal	11-12
parts list	
pump cut-a-way	
Frame 2 Metal	13-14
parts list	
pump cut-a-way	
Frame 3 Metal	15-16
parts list	
pump cut-a-way	
Frame 4 Metal	17-18
parts list	
pump cut-a-way	
Frame 1 and 2 Non-Metallic	19-20
parts list	
pump cut-a-way	
Pump System Trouble Shooting	21
Spare Parts Ordering	25

HYDROVOIR®

All Wilfley process pumps can be equipped with a Hydrovoir seal. This seal provides additional leakage protection in severe services. The Hydrovoir can be retrofitted to your existing model AG and AF pumps and is available on new Wilfley pumps. For complete details on the Hydrovoir or additional information about Wilfley pumps call or write our office in Denver, or the representative in your area. Please do not hesitate to contact us concerning any aspect of our products and services.

WILFLEY

A. R. Wilfley & Sons, Inc./P.O. Box 2330/Denver, Colorado 80201
 Telex: 054-543 Fax: 303-779-1277
 1-303-779-1777 1-800-525-9930



Safety Precautions

Illinois Location:

(847) 841-7867

860 Church Rd Elgin, IL 60123

Minnesota Location:

(651) 758-7867

330 Mill Bay South Suite 1511 Afton, MN 55001

Throughout this manual, references are made concerning specific pump configurations corresponding to specific frame sizes. We have provided detailed cutaways for both metal and non-metallic models to show general configurations. To identify the frame size of your pump please refer to the table below. The frame size is also embossed on the side of the frame on some models, as well as the serial number plate.

Characteristics	Frame	Dimension-Inches	mm
Height-base to shaft	1	5 ¼ (5.25)	133
	2	8 ¼ (8.25)	210
	3	10 (10.0)	254
	4	14 ½ (14.5)	368
Frame Dia. at Rear	1	6 ¾ (6.62)	168
	2	8 (8)	203
	3	9 (9)	229
	4	12 ⅝ (12.31)	313
Shaft Dia. at Coupling End	1	¾ (.875)	22.2
	2	1 ⅛ (1.125)	28.6
	3	1 ¼ (1.125)	28.6
	4	2 ¾ (2.375)	60.3
Impeller Hub Dia.	1	1 ⅝ (1.31)	33.4
	2	1 ¾ (1.75)	44.5
	3	1 ⅞ (1.88)	47.6
	4	3 ⅞ (3.437)	87.3

Special Service

Your Wilfley AG pumps may be returned to the factory, at any time, for complete overhaul and repair. Each pump is completely disassembled and worn or inoperable parts are replaced. All rebuilt pumps are subjected to the same testing procedures as newly constructed units. Wilfley can also rebuild seal housing assemblies. (See Spare Parts Ordering.)

For more information on rebuilding, contact A.R. Wilfley and Sons
1-303-779-1777 / 1-800-525-9930

Like all machinery, centrifugal pumps can be dangerous if used improperly. Any of the following list of misuses may result in a pump which does not function properly. A pump which does not function properly may be a hazard and could cause damage or injury.

For maximum safety and reliability use only factory supplied parts and closely follow all maintenance and operating recommendations and instructions.

Do not change the pumping conditions or installation of a Wilfley pump without consulting A.R. Wilfley & Sons, Inc. first to ascertain if the pump is capable of handling the new conditions and/or fluid.

It is not possible to list all the conceivable misuses. Therefore, the following list is not meant to be complete and is provided only as a guide and as examples of the types of misuse which can damage a pump and cause injury. The list will also give a good idea of the kinds of misuses which will void any and all warranties.

1. Do not run a pump with the discharge valve closed.
2. Do not run a pump in the reverse direction.
3. Do not start a pump which is "windmilling" in the reverse direction due to fluid flowing back down the discharge pipe.
4. Do not continue to operate a pump when there are indications that something is rubbing, binding or knocking.
5. Do not continue to run a pump which gives an indication of overheating.

6. Do not operate a pump with the belt or coupling guard removed. Make sure the guard fits snugly around the belts or couplings so there are no openings.
7. Do not operate a pump if the governor weights are of different sizes.
8. Do not operate a pump that is vibrating, surging or making abnormal noise.
9. Do not work on a pump unless the drive system is locked out and the pump is disconnected from the drive system.
10. Do not connect the pump to the drive system without first checking to see that the drive system is running in the correct direction.
11. Do not rely on the factory's alignment of pump and the drive system. Alignment may have changed during shipment.
12. Do not put a cold liquid in or on a hot pump or a hot liquid in or on a cold pump.
13. Do not hit a pump with any object.
14. Do not use worn or faulty parts.
15. Do not stick hands, arms, legs or any other object into the discharge or intake or any other opening of a pump.
16. Do not weld attachments to the pump.
17. Do not apply external heat to the pump.
18. Do not lift the pump by its case only.
19. Do not examine a pump without using proper eye and face protection.



General Installation

Illinois Location:

(847) 841-7867

860 Church Rd Elgin, IL 60123

Minnesota Location:

(651) 758-7867

330 Mill Bay South Suite 1511 Afton, MN 55001

Inspection upon Arrival

Your pump has been carefully inspected and tested prior to shipment to assure that it meets your requirements. Please inspect the pump upon arrival for any damage which may have occurred during shipment. Report any damage immediately to the carrier. Leave all shipping covers attached to the pump unit until it is ready for installation. If installation is to be delayed more than 15 days, the pump shaft should be rotated by hand once a week to lubricate the bearings and prevent rusting.

Choosing Pump Location

The following recommendations may be helpful when choosing the best location for your pump.

- a. Locate the pump as close to the liquid source as practical so that the intake pipe is short and direct with a minimum of elbows, fittings and valves.
- b. Place the pump in a location so that the unit is accessible for inspection during operation as well as for maintenance operations involving removal and disassembly.

Foundation

The foundation should be sufficient to absorb any vibration and to form a permanent, rigid support for the sub-

base. This is important in maintaining the correct alignment of the direct connected unit. A concrete foundation on a solid base is satisfactory. Foundation bolts of the proper size should be embedded in the concrete located by the outline drawing.

Alignment

The pump and motor are aligned at the factory before shipment. Realignment may be necessary after the complete unit has been leveled on the foundation and after the foundation bolts have been tightened. Procedures for checking and aligning the pump components may be found in the Hydraulic Institute Standards.

Piping

Both intake and discharge pipes should be supported independently near the pump so that when the flange bolts are tightened no strain will be transmitted to the pump casing.

Pipe flanges connected to non-metallic plastic pumps must be flat faced and completely gasketed from the solution being pumped.

Discharge Piping

A valve should be installed in the discharge line to prevent fluid from flowing back through the pump when it is shut down. The valve should block the discharge line during maintenance.

Intake Piping

Care should be taken in sizing and locating suction piping to prevent cavitation. A valve should be installed in the intake line to prevent fluid from flowing into the pump when it is shut down.

Auxiliary Piping-Purge Plumbing

When required, purge piping is supplied with the pump. External connection should be made at the pump so that purge flow can be varied as required by valving and the pressure can be monitored. Piping, fittings and gauges must be corrosion resistant to the fluid being pumped.

Steam Jacketed Pump

Wilfley Model "AG" steam jacketed pumps are supplied with a jacketed case and/or a stationary seal ring housing. The jacketed parts have two pipe connections for steam inlet and outlet. Steam pressure should be regulated to 150 psi maximum at the pump.

Locations of all steam connections are defined on appropriate outline dimension drawings supplied with your pump.



Operating and General Servicing Recommendations

Illinois Location:

(847) 841-7867

860 Church Rd Elgin, IL 60123

Minnesota Location:

(651) 758-7867

330 Mill Bay South Suite 1511 Afton, MN 55001
Pump Storage

If the pump is inoperative for a long period of time, it is recommended that the pump be flushed and drained to minimize corrosion. It is also advisable to drain the lines and case if there is a possibility of freezing. If the pump is to be stored for more than 15 days, the pump should be rotated once a week to lubricate and to prevent rusting of the bearings.

Pre-starting Recommendations

Please perform the following operations before attempting to start the pump.

- a. Visually check all main and auxiliary piping to insure that all connections have been properly made.
- b. The Oil level in the frame should be to the middle of the glass. If oil is low, fill with clean oil.
- c. Check voltage, fuse, starter amperage ratings and frequency on the motor nameplate against the electrical supply characteristics.
- d. Visually inspect all electrical connections to the motor and control circuit.

e. CHECK THE ROTATION OF THE MOTOR BY MOMENTARILY STARTING THE MOTOR WITH THE MOTOR DISCONNECTED FROM THE PUMP ASSEMBLY. DIRECTION OF ROTATION MUST BE AS SHOWN BY THE ARROW ON THE PUMP CASE AND THE DIRECTION OF ROTATION PLATE ON THE TOP OF THE FRAME. STARTING OR RUNNING PUMP BACKWARDS WILL CAUSE DAMAGE TO INTERNAL PARTS.

Starting

Before starting the pump, it is advisable to have the pump casing and suction line filled with liquid. However, because no rubbing components are contained in this pump such as seals or packing, no damage will result if started dry. It is normal to have the discharge valve momentarily closed when the pump is started since much less horsepower is required under these conditions.

DO NOT OPERATE THE PUMP IN A DEAD-HEADED (NO-FLOW) CONDITION.

Shutdown

Close the suction valve and discharge valve, then stop the pump.

General Servicing

Your Wilfley Model "AG" pump is designed to provide long and trouble-free service with a minimum of maintenance. It is recommended that the pump be inspected at regular intervals. It is also suggested that a service record be kept for the pump.

Motor

Please refer to the manufacturer's motor manual for recommended service instructions. It is recommended that the motor be well ventilated when in operation.

Periodic Servicing

The following table contains recommended service checks which should be performed on a periodic basis.

	Upon Installation	After First Start-Up	Every Week	Every Month	Every 6 Months
Flow, pressure and temperature (a)		●	●		
Oil level (b)	●	●	●		
Visual (c)		●	●		
Noise/vibration		●	●		
Oil change					●

a. Flow, Pressure and Temperature: All flow pressure and temperature gauges should be monitored to ensure that the pump is operating within specified limits. If the frame bearing temperatures are monitored, this temperature should not exceed 220°F (104°C).

b. Oil level: A window sight glass (item 21) is provided for easy monitoring of oil level. The oil supply should be visible in the middle of the window sight glass. Add clean oil when needed. Oil should be periodically checked to be sure lubricant is clean.

c. Visual: Periodic visual inspection should be made of the pump and its installation. This inspection should include the following:

1. All mountings supports should be secure.
2. All external nuts, bolts and fittings should be tight.
3. All suction and discharge piping should be secure.
4. All surfaces and joints show no signs of leakage.



General Repair and Part Replacement Instructions

Illinois Location:

(847) 841-7867

860 Church Rd Elgin, IL 60123

Minnesota Location:

(651) 758-7867

330 Mill Bay South Suite 1511 Afton, MN 55001

The "Oil viscosities and temperature ranges for ball bearing lubrication" table below will specify proper lubricant for your application.

Oil Viscosities and Temperature Ranges for Ball Bearing Lubrication

Range, Degrees F.	Viscosity
+30 to +100	SAE 10
+30 to +200	SAE 30

For colder temperatures down to -40°F use synthetic oil, SAE 30

Oil Capacity

(Approximate)

	Oz.	cc
Frame 1	11	320
Frame 2	35	1020
Frame 3	45	1325
Frame 4	82	2420

General

The section views for each type of Model "AG" pump shows the parts in their proper relationship and should be used as guides for disassembly and reassembly. Part numbers are listed in approximate order of assembly sequence. Before disassembling the unit, thoroughly drain fluid out of the case and expeller cavities. Disassemble the pump only to the extent necessary to repair.

Inspection

Visually inspect all metal and plastic parts for cracks, fractures, burrs, scoring, excessive wear or other visually detectable faults. Check o-rings, seals and gaskets for cuts, tears, deterioration and loss of resilience. Replace as required.

Parts Handling and Cleaning

Always use the proper tools for the job. Clean all parts. Protect each part from contamination. If parts are not to be reinstalled in a short time, protect them from rust and corrosion.

Special Disassembly Instructions

External Plumbing

If your pump uses purge piping or has a steam-jacketed stationary seal ring housing, the connection nipples through the frame openings must be removed before the case plate assembly can be removed.

Seal Housing Unit

After the impeller (item 48) has been unscrewed from the shaft (item 1) the entire seal housing assembly, containing the check valve seals and the secondary expeller, may be removed as a unit for inspection, repair or unitary replacement (kit #7300). Use the groove provided on the outside diameter of the metal case plate (item 32) to pry out this assembly if necessary.

Bearing Unit and Frame:
If shaft removal is necessary, remove the retaining cap screws (item 13) and carefully tap the impeller end of the shaft with a rubber-faced mallet to force the shaft bearing assembly out of the frame (item 11). DO NOT discard bearing retainer housing shims which maintain the impeller clearance. Impeller clearance shall be checked after the installation of new frames, shafts, bearings or wear parts.

NOTE: When externally cleaning or storing the bearing unit, make sure that the governor sleeve (item 28) remains on the shaft. Removal of the governor sleeve exposes the front bearing to the outside and creates the potential for bearing contamination.

Bearings:

Bearings should not be removed from the shaft unless replacement is certain.

PLEASE KEEP BEARING AS CLEAN AS POSSIBLE.



Pump Assembly Instructions

Illinois Location:

(847) 841-7867

860 Church Rd Elgin, IL 60123

Minnesota Location:

(651) 758-7867

General

Assembly of each pump should be essentially in the sequence of numbers shown on the section view for that unit. Where total disassembly has not been performed, reassembly should start at the appropriate point and continue as necessary.

Permanently attached items such as name tags, serial number plates and direction of rotation plates do not require replacement and should never be removed.

Inspection

Every part should be carefully inspected before reinstallation for general wear, corrosive attack and damage. Where critical, inspection instructions have been given, and these may include a sketch for clarity.

Bearing Unit Assembly (items 1 to 9)

Inspection:

a. Shaft (item 1): The threaded end of the pump shaft should not show any signs of corrosion or chemical attack. The drive end of the shaft should be free of all rust or burrs. The shaft should not be bent.

b. Bearings (items 2 & 5): There should be no signs of rusting or contamination by dirt, chips or metal particles. When slowly rotated, there should be no points of drag, hangup, or looseness.

Assembly: The clamp ring (item 4) must be slipped on the shaft between the bearings before pressing on the final bearing. Bearings (items 2 and 5) should be preheated to 200° - 260°F. in a clean fluid or on a demagnetizing bearing heater and pressed on the shaft (item 1).

A properly sized pressing ring should be used to insure that the force is only applied on the inner race of the bearing. Make sure that all bearings are firmly seated against the shaft shoulder and the bearing lock nut is tight-

ened immediately after the bearings are pressed on the shaft. The lock nut should be retightened after the shaft and bearings have cooled to room temperature. There should be no clearance or looseness in the duplex bearing set when properly assembled.

CAUTION

Angular contact duplex thrust bearings **MUST** be mounted back-to-back. Internal loading and loss of clearance with normal heat generation can result in damage if mounted improperly.

Angular Contact Duplex Bearing Mountings

Thin outer races must oppose each other

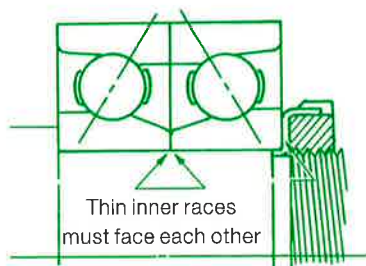
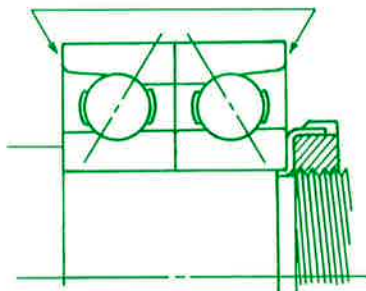

If unsure of correct bearing mounting, contact your local bearing supplier or A.R. Wilfley & Sons.

330 Mill Bay South Suite 1511 Afton, MN 55001

The rear oil seal (item 9) should be pressed into the counterbore of the bearing retainer housing (item 6) until flush. The bearing retainer housing should then be slipped carefully over the rear duplex thrust bearings and attached with the appropriate screws and lock-washers to the clamp ring.

Frame Assembly (items 11 to 24)

Inspection:

a. Frame (item 11): The front case plate pilot must be free of rust and corrosion. The internal oil cavity should be clean and free of dirt, rust, corrosion, sand particles, metallic chips and particles.

b. Frame O-Ring (item 12): The frame o-ring should be free of any nicks or abrasions.

c. Front Bearing Oil Seal (item 17): Carefully inspect the oil seal for damage. The seal lips must be free of cracks, abrasion, wear and hardening. Replace if damaged.

d. Window Sight Glass (item 21): The window sight glass should be wiped clean to allow accurate monitoring of oil levels.

Assembly: Lubricate the frame o-ring generously with grease so that it will be retained in its groove while the shaft assembly is installed.

NOTE: In a Frame 3 bearing unit, the frame o-ring groove is located on the outside diameter of the bearing retainer housing. For all other frames the groove is located in the bore of the frame.

Carefully fit the oil seal into the front of the frame. Open end containing spring goes towards the bearing.



Illinois Location:

(847) 841-7867

860 Church Rd Elgin, IL 60123

Minnesota Location:

(651) 758-7867

330 Mill Bay South Suite 1511 Afton, MN 55001

Insert the threaded end of the shaft assembly into the frame and guide the shaft out through the front bore so as not to damage the oil seal. Rotate the bearing retainer housing so that the embossed part number and the word "Top" is located at the top of the frame. Secure loosely with the correct screws and lock washers. Install the window sight glass, drain plug and fill plug into the frame.

Governor Sleeve Assembly (item 28 through 30):

- a. Governor Sleeve (item 28): The end of the governor sleeve and the internal o-ring grooves should be free of burrs, nicks, rust or corrosive attack. The governor weight pin hole should be round, not elongated.
- b. Governor Sleeve O-Ring (item 29): The governor sleeve o-ring should be soft, pliable and free of nicks.
- c. Governor Weights (item 30): Insure that the governor weights swing freely without binding. Visually inspect the nose of the governor weights for excessive wear or flat spots. Replace if damaged.

Governor Weight Nose
Smooth and No Wear

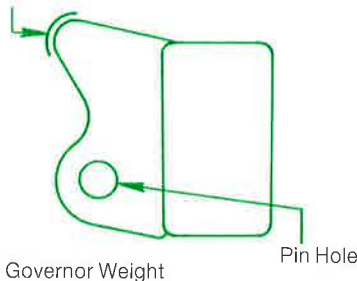

Assembly: Lubricate the governor sleeve o-ring and install into the groove in the bore of the governor sleeve assembly. Carefully slide the governor sleeve assembly onto the shaft and through the oil seal in the frame. Rotate the governor sleeve until the weights are positioned in a horizontal plane and noses is away from shaft.

Seal Housing Assembly (Metal Pump Only) (items 32 to 46)

NOTE: The wetted end assembly procedures of metal and non-metallic pumps are different. The following instructions are for metal pumps only. See Page 10 for non-metallic pump assembly instructions.

Inspection:

- a. Case Plate (item 32): The case plate should be inspected for unusual wear or corrosive attack. Replace if necessary. Carefully inspect the case and case plate gasket surfaces for scratches, dents or cracks.
- b. Expeller (item 33): The outer diameter of the expeller hub (side with the lead-in chamfer) must be smooth and polished. If scratches, corrosion or deposits exist, this surface may be reworked by lightly polishing. To increase part life polish only enough to remove imperfections. Do not exceed minimum allowable hub diameters (See Table #1).

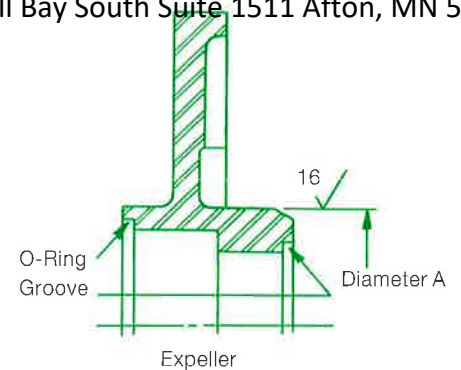

- c. Rotary Seal Housing (item 34): The flange face of the rotary seal housing must be free of marks, scratches and chemical attack. The flange face may be turned on a lathe to a maximum depth of .015 inch. Polish to 32 RMS. The bore ID that positions the rotary seal housing seal must also be smooth and free of scratches.
- d. Rotary Seal Ring (item 37): Both side faces of the rotary seal ring must be smooth and scratch free. The minimum allowable width of the seal ring is .125-inch. The faces of the rotary seal ring may be polished on a lap plate or crocus cloth laid on a flat surface.

Rotary Seal Housing

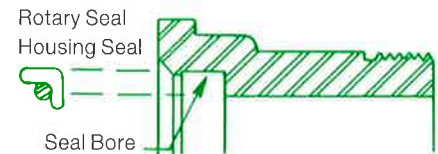

Table #1

Frame Size	(Min. Allowable - See Diameter A in following sketch)	
	Inches	mm
1	1.864	47.35
2	2.240	56.90
3	3.075	78.11
4	3.815	96.90



Illinois Location:

(847) 841-7867

860 Church Rd Elgin, IL 60123

Minnesota Location:

(651) 758-7867

330 Mill Bay South Suite 1511 Afton, MN 55001

e. Actuator Body (item 43): Visually inspect the area between the drive slots and lugs where the governor weights press. There should be no noticeable scuffing, dimpling or wear.

NOTE: On all units except some frame 1 metal pumps, the governor weights may be rotated 90° from the original position to obtain a new clean working surface.

f. Stationary Seal Ring Housing (item 39): The seal ring seat and the gasket surface of the housing must be smooth, crack-free and polished (see sketch). The seal seat surface (B in following sketch) may be turned on a lathe to a maximum permissible counterbore depth B (see following Table #2).

Table #2
(Maximum Allowable Depth of Seal Seat - see B in the following sketch)

	Inches	mm
1AG	.261	6.63
2AG	.240	6.10
3AG	.200	5.08
4AG	1.016	25.81

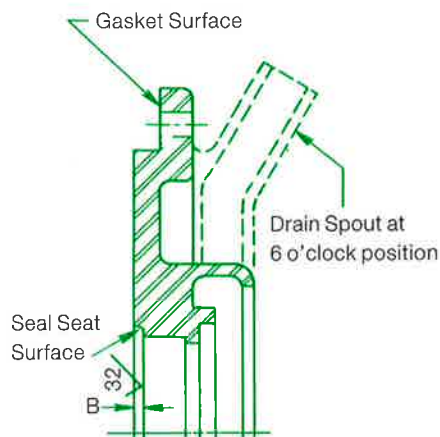

Seal Housing Assembly

NOTE: The seal housing assembly and final assembly instructions for the Frame 4 metal pumps can be found on page 9. All other metal AG pumps use the following instructions.

Assembly: Lubricate the rotary seal housing seal with grease and install in the rotary seal ring housing. Install the seal carefully into the groove with your fingers, pushing the body of the seal into the bore of the rotary housing until it is below retaining lips.

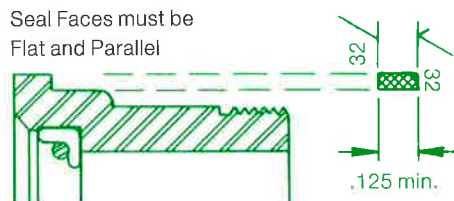

Slide rotary seal ring onto the rotary seal housing (see sketch).

Insert the rotary seal housing (item 34) through the stationary seal ring housing (item 39) so that the rotary seal ring (item 37) seals properly in the counterbore of the stationary seal ring housing.

Lubricate the threads of the rotary seal ring housing with an anti-seize compound and screw onto the actuator body.

NOTE: The Frame 1 actuator body is attached to the rotary seal housing with two #10 screws. DO NOT USE LOCK WASHERS.

Carefully insert the governor spring (item 42) inside the rotary seal housing. Be careful not to damage the rotary seal housing seal.

Lay the expeller in the open cavity of the case plate with the vanes facing upward.

Position the case plate gasket (item 38) on the case plate.

Position the stationary seal housing assembly over the end of the expeller hub. Carefully push down on the assembly so that the rotary seal engages and slides over the expeller hub compressing the governor spring.

Attach stationary seal housing cap screws (item 41).

To test the completed assembly press down on the end of the actuator body and release quickly. The parts should immediately snap back when pressure is removed. The housing should slide at least 1/16 in.

Final Assembly: Impeller (item 48), Case (item 50) Seal Housing Assembly and Frame Assembly Lubricate the expeller o-ring (item 46) with grease. Slide the o-ring over the threaded end of the pump shaft and up against the exposed end of the governor sleeve.

Rotate the actuator body within the seal housing assembly so that the retaining slots for the governor weights are at right angles to the drain spout.

Governor weights must be horizontal and pushed back toward the bearing housing. Slide the seal housing assembly into the bore of the frame.

Grease and install the impeller o-ring (item 47) in the groove between the exposed end of the expeller and shaft.

Start the threads of the impeller (item 48) onto the pump shaft. TIGHTEN THE IMPELLER ON THE SHAFT BY TURNING THE DRIVE END OF THE SHAFT WHILE HOLDING THE IMPELLER STATIONARY TO PREVENT THE IMPELLER O-RING FROM SLIDING AND POPPING OUT OF ITS GROOVE.

Attach the case (item 50) to the frame and screw with case bolts, nut washers. See page 11 for instructions on setting the Impeller clearance.



Illinois Location:

(847) 841-7867

860 Church Rd Elgin, IL 60123

Minnesota Location:

(651) 758-7867

Special Assembly Instructions for the Frame 4 Model AG Pumps.

The Frame 4 Model AG pumps require special final assembly instructions. Follow instructions in the AG Operating Handbook pages 6 through 9 (Item 5) and continue the final assembly with the instructions listed below.

1. Insert the rotary seal housing (Item 34) with its seal (Item 36) and rotary seal ring (Item 37) through the stationary seal housing (Item 39), be sure that the rotary seal housing seats properly in the counterbore of the stationary seal housing.
2. Lubricate the rotary seal housing threads. Screw the actuator body (Item 43) and the rotary seal housing together.
3. Slide this assembly onto the shaft.
4. Slip the governor spring (Item 42) onto the shaft.
5. Lubricate the impeller o-ring (Item 47) and expeller o-ring (Item 46) and place them into their pockets in the expeller.
6. Install the expeller (Item 33) on the shaft so as not to pinch the o-rings.
7. Thread the shaft assembly tool onto the shaft. This tool pushes the expeller hub under the rotary seal housing seal and compresses the governor spring.
8. Place the case plate gasket (Item 38) into its bore in the case plate (Item 32).
9. Position the case plate assembly on the stationary seal housing.
10. Clamp the case plate onto the frame with 2 c-clamps placed approximately diametrically opposite one another.
11. Remove the shaft assembly tool.

12. Screw the impeller (Item 48) onto the shaft by holding the impeller still and turning the shaft. The shaft can be easily turned by using a Wilfley shaft wrench or any standard wrench. Before using a standard wrench, slide the coupling hub onto the shaft, to avoid damaging it, and place the wrench across the flats on the hub.
13. Press the case wear ring (Item 70) closed into the case (Item 50).
14. Remove the clamps.
15. Attach the case assembly on the pump and secure with bolts, nuts and washers. See page 10 for instructions on setting the Impeller clearances.

Seal Housing and Final Assembly (Non-Metallic Pump Only)

NOTE: The seal housing and final assembly procedures of metal and non-metallic pumps are different. The following instructions are for non-metallic pumps only. See page 8 for metal pump assembly instructions.

Pipe flanges that are connected to non-metallic pumps must be flat faced and completely gasketed from the solution being pumped.

Inspection:

a. Rotary Seal Housing (item 34): The flange face of the rotary seal housing must be free of marks, scratches and chemical attack. The bore ID that positions the rotary housing seal must be smooth and free of scratches.

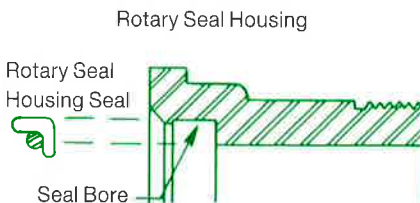

b. Stationary Seal (Item 35): The seal face must be smooth and free of scratches.

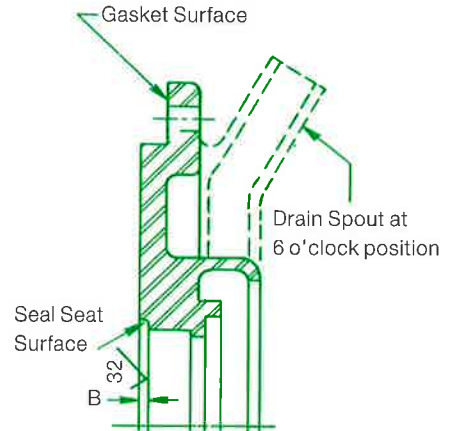

c. Actuator Body (item 43): Visually inspect the area between the drive slots and lugs where the governor weights press. There should be no noticeable scuffing, dimpling or wear in the area.

Assembly: Lubricate the rotary seal housing seal (Item 36) with grease and install in the bore of the rotary seal ring housing (Item 34). Install the seal carefully with your fingers. Be sure the seal seats securely below the retaining lip.

Press the stationary seal ring (item 35) into the housing (item 39).

Insert the rotary seal housing (item 34) through the stationary seal ring housing (item 39) and screw into the actuator body (Item 43).



Illinois Location:

(847) 841-7867

860 Church Rd Elgin, IL 60123

Minnesota Location:

(651) 758-7867

330 Mill Bay South Suite 1511 Afton, MN 55001

**Table #7
Clearance Settings**

Frame Size	Metallic Pumps	Non-Metallic Pumps
1	.020 - .025	.020 - .025
2	.020 - .025	.025 - .030
3	.020 - .025	
4	.035 - .040	

**Table #8
Shim Thickness Table**

Blue	.005
Brown	.010
Orange	.030

For example, on a metallic frame 4 pump the gap between frame and bearing retainer housing = .140 inch
 Subtract from Table #7 - .035 inch
 Shim set thickness .105

The shim thickness table shows 3 orange shims, one brown shim and one blue shim equals a thickness of .105. Install these shims and tighten the bearing retainer housing cap screws (item 13).

Rotate the shaft to ensure there is no metal to metal rubbing. The shaft should have uniform seal rubbing throughout its rotation.

Adjustment With No Case

1. Case plate must be tight to the frame
2. Impeller must be tight on the shaft
3. Always set to a smaller gap per given shim (expeller/case)

Final Assembly: (Non-metallic Pumps Only)

NOTE: If the final assembly is to be performed on a bench, tip the pump frame back, the remaining parts will nest into the frame.

Inspection:

a. Case Plate (item 32): The case plate should be inspected for unusual wear or corrosive attack. Replace as necessary. Carefully inspect the case and case plate gasket surfaces for scratches, dents or cracks.

b. Expeller (item 33): The outer diameter of the expeller hub (side with the lead-in chamfer) must be smooth.

Assembly: Seat the seal housing assembly into the bore of the frame.

Slide the governor spring (Item 42) into the bore of the rotary seal housing. Be sure that it seats properly and does not damage the rotary seal ring.

Lubricate the expeller o-ring (Item 46) and install in the groove on the hub of the expeller (Item 33). Slide the expeller onto the shaft. Be careful not to pinch or damage the expeller o-ring during assembly. Push the expeller on the shaft to be sure that it engages and compresses the spring. Place the impeller seal (Item 47) on the hub of the expeller.

Place the rear case plate (Item 42) in the bore of the stationary seal housing. Spring tension may prevent a case plate from fully seating in the stationary seal housing. These parts will be drawn together once the case is placed on the pump.

Screw the impeller (Item 48) on the shaft. Once the impeller has been securely tightened, turn the shaft to be sure the entire assembly turns easily.

Place the case gasket (Item 49) on the shoulder of the case plate. Slide the case (Item 50) carefully over the impeller and case plates and attach with appropriate case bolts, nuts and washers to the frame.

Pump Clearances:

The Impeller clearance must be set for the pump to operate at its peak performance. The clearance is set and maintained by shims placed between the frame (item 11) and the bearing retainer housing (item 6).

The Impeller clearance should be checked after the installation of new frames, shafts, bearings or wear parts.

Setting Clearances:

Install a 5/16-18 UNC screw into the threaded hole in the bearing retainer housing (Item 6). Tighten the screw, drawing the housing cover from the frame until the internal wetted and parts rub. This contact can be detected by turning the shaft until rubbing occurs. It is important to distinguish between the constant drag from the seals and the increasing drag caused by internal contact. Measure the gap between the frame and the rear bearing housing flange. Subtract the clearance gap required for your pump. See table 7. Build a shim pack to equal the remaining gap. See table 8. Install the shims between the frame and bearing retainer housing. Tighten the bearing housing to the frame. Turn the shaft to be sure that only the rubbing of the seals is present.

Frame 1 Model AG Metal Pump

Illinois Location:

(847) 841-7867
860 Church Rd Elgin, IL 60123

Minnesota Location:

(651) 758-7867
330 Mill Bay South Suite 1511 Afton, MN 55001

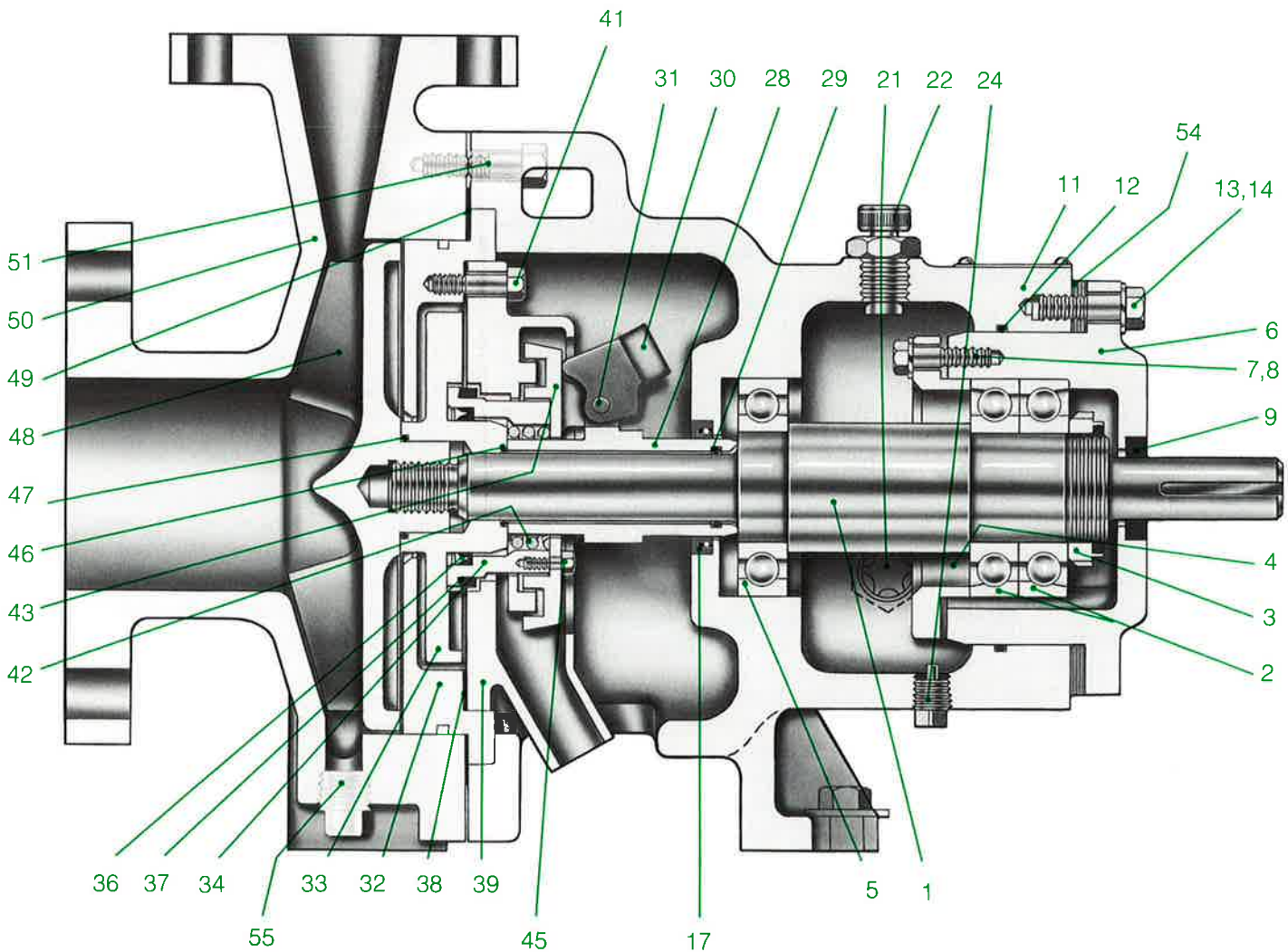

Part numbers are listed in approximate order of assembly sequence.



Parts List and Recommended Spare Parts

Illinois Location:

(847) 841-7867
860 Church Rd Elgin, IL 60123

Minnesota Location:

(651) 758-7867
330 Mill Bay South Suite 1511 Afton, MN 55001

	#7000	#7100	#7300	#7400	#7450		
Item Number	Number Required	Spare Parts Kit	Shaft Assembly Kit	Seal Housing Kit	Pump Gasket Kit	Wet End Gasket Kit	Description
1	1		1				Shaft
2	2	2	2				Rear Bearing
3	1		1				Rear Bearing Locknut
4	1		1				Clamp Ring
5	1	1	1				Front Bearing
6	1						Bearing Retainer Housing
7	4						Clamp Ring Lockwasher
8	4						Clamp Ring Cap Screw (5/16-18 unc x 1)*
9	1				1		Bearing Retainer Housing Oil Seal
11	1						Frame
12	1				1		Frame O-Ring (2-157)*
13	4						Bearing Retainer Housing Cap Screw 3/8-16 unc x 1-1/4)*
14	4						Bearing Retainer Housing Cap Screw Lock Washer
17	1				1		Front Bearing Oil Seal
21	1						Window Sight Glass
22	1						Oil Filler Plug
23	1						Closure Plate (not illustrated)
24	1						Oil Drain Plug
25	1						Oil Lubrication Plate (not illustrated)
26	1						Serial Number Plate (not illustrated)
27	12						Plate Drive Screw (not illustrated)
28	1						Governor Sleeve
29	1						Governor Sleeve O-Ring (2-120)*
30	2						Governor Weight
31	2						Governor Weight Pin
32	1	1		1			Case Plate
33	1	1		1			Expeller
34	1	1		1			Rotary Seal Housing
36	1			1	1	1	Rotary Seal Housing Seal
37	1	2		1			Rotary Seal Ring
38	1			1	1	1	Case Plate Gasket
39	1		1				Stationary Seal Ring Housing
41	4			4			Stationary Seal Ring Housing Cap Screw (5/16-18 unc x 1)*
42	1	1		1			Governor Spring
43	1			1			Actuator Body
45	2			2			Actuator Body Cap Screw (#10-24 unf x 1/2)*
46	1				1	1	Expeller O-Ring (2-022)*
47	1				1	1	Impeller O-Ring (2-027)*
48	1	1					Impeller
49	1				1	1	Case Gasket
50	1	1					Case
51	8						Case Cap Screw (3/8-16 unc x 1-1/2)*
52	1						Rotation Plate (not illustrated)
54	1	1					Bearing Retainer Housing Shim (Set)
55	1						Case Drain Plug (optional)

* These numbers refer to the size of the part. They may be obtained locally but special care must be taken to duplicate the original material.
All other parts should be obtained from A.R. Wilfley and Sons.

Frame 2 Model AG Metal Pump

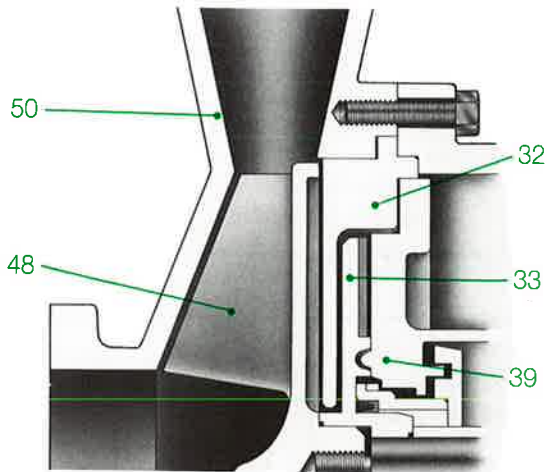

Detail of special case plate configuration for modified expellers

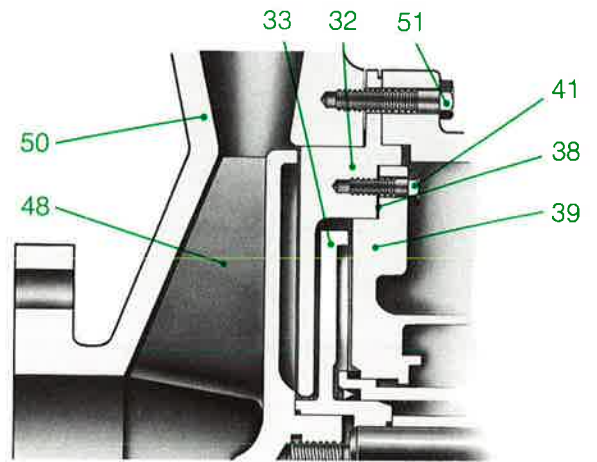

Detail of special case plate configuration for 10" diameter impellers

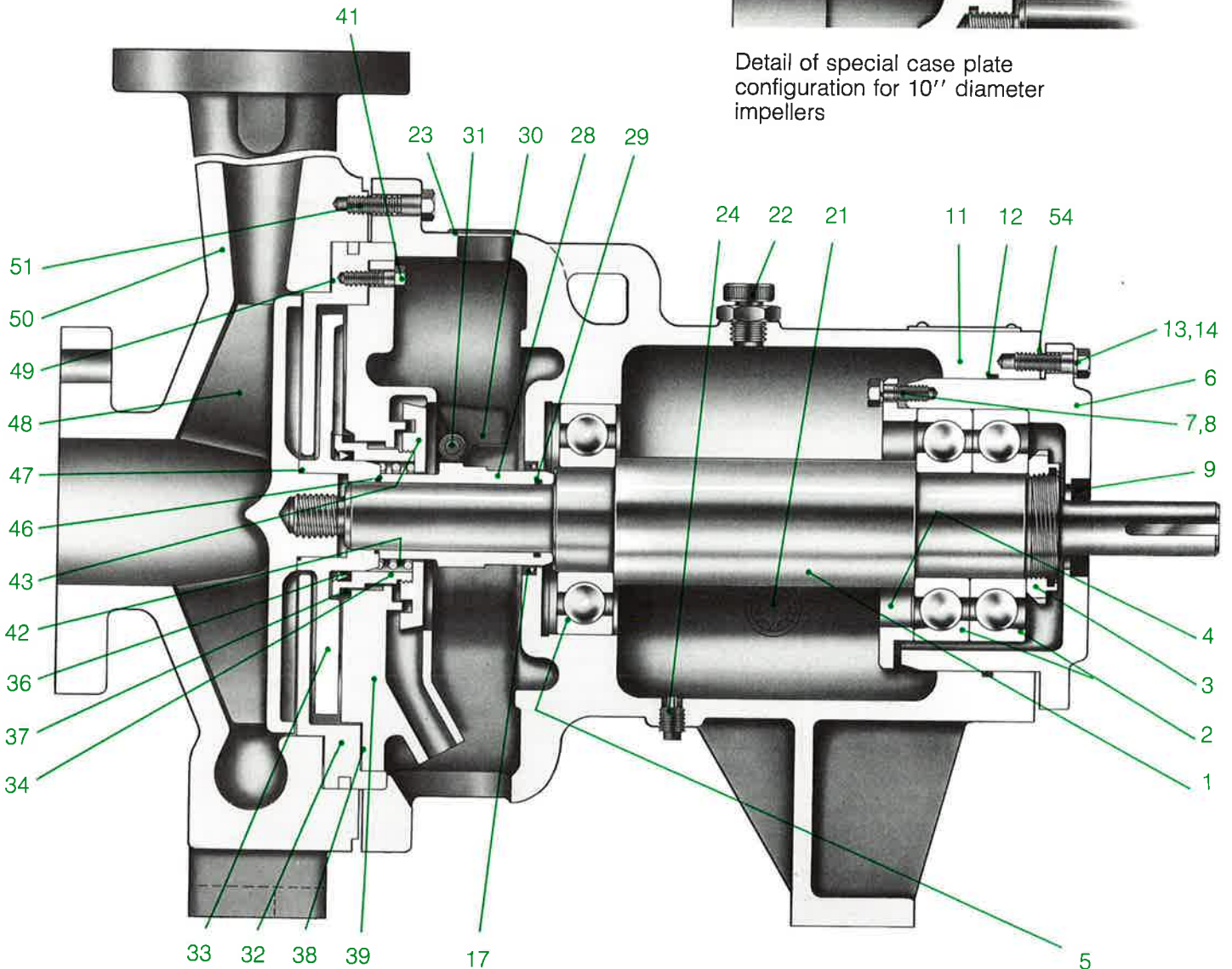

Part numbers are listed in approximate order of assembly sequence.



Parts List and Recommended Spare Parts

Illinois Location:

(847) 841-7867
860 Church Rd Elgin, IL 60123

Minnesota Location:

(651) 758-7867
330 Mill Bay South Suite 1511 Afton, MN 55001

	#7000	#7100	#7300	#7400	#7450		
Item Number	Number Required	Spare Parts Kit	Shaft Assembly Kit	Seal Housing Kit	Pump Gasket Kit	Wet End Gasket Kit	Description
1	1		1				Shaft
2	2	2	2				Rear Bearing
3	1		1				Rear Bearing Locknut
4	1		1				Clamp Ring
5	1	1	1				Front Bearing
6	1						Bearing Retainer Housing
7	4						Clamp Ring Lockwasher
8	4						Clamp Ring Cap Screw (5/16-18 unc x 1)*
9	1				1		Bearing Retainer Housing Oil Seal
11	1						Frame
12	1				1		Frame O-Ring (2-163)*
13	4						Bearing Retainer Housing Cap Screw 3/8-16 unc x 1-1/4)*
14	4						Bearing Retainer Housing Cap Screw Lock Washer
17	1				1		Front Bearing Oil Seal
21	1						Window Sight Glass
22	1						Oil Filler Plug
23	1						Closure Plate
24	1						Oil Drain Plug
25	1						Oil Lubrication Plate (not illustrated)
26	1						Serial Number Plate (not illustrated)
27	12						Plate Drive Screw (not illustrated)
28	1						Governor Sleeve
29	1				1		Governor Sleeve O-Ring (2-126)*
30	2						Governor Weight
31	2						Governor Weight Pin
32	1	1		1			Case Plate
33	1	1		1			Expeller
34	1	1		1			Rotary Seal Housing
36	1			1	1	1	Rotary Seal Housing Seal
37	1	1		1			Rotary Seal Ring
38	1			1	1	1	Case Plate Gasket
39	1	1		1			Stationary Seal Ring Housing
41	10			10			Stationary Seal Ring Housing Cap Screw (5/16-18 unc x 1)*
42	1	1		1			Governor Spring
43	1			1			Actuator Body
46	1				1	1	Expeller O-Ring (2-028)*
47	1				1	1	Impeller O-Ring (2-031)*
48	1	1					Impeller
49	1				1	1	Case Gasket
50	1	1					Case
51	8						Case Cap Screw (3/8-16 unc x 1-1/2)*
52	1						Rotation Plate (not illustrated)
54	1	1					Bearing Retainer Housing Shim (Set)
55	1						Case Drain Plug (optional)
63	1						Drain Hose (not illustrated)
64	1						Drain Hose Clamp (not illustrated)

* These numbers refer to the size of the part. They may be obtained locally but special care must be taken to duplicate the original material. All other parts should be obtained from A.R. Wilfley and Sons.

Frame 3 Model AG Metal Pump

Illinois Location:

(847) 841-7867

860 Church Rd Elgin, IL 60123

Minnesota Location:

(651) 758-7867

330 Mill Bay South Suite 1511 Afton, MN 55001

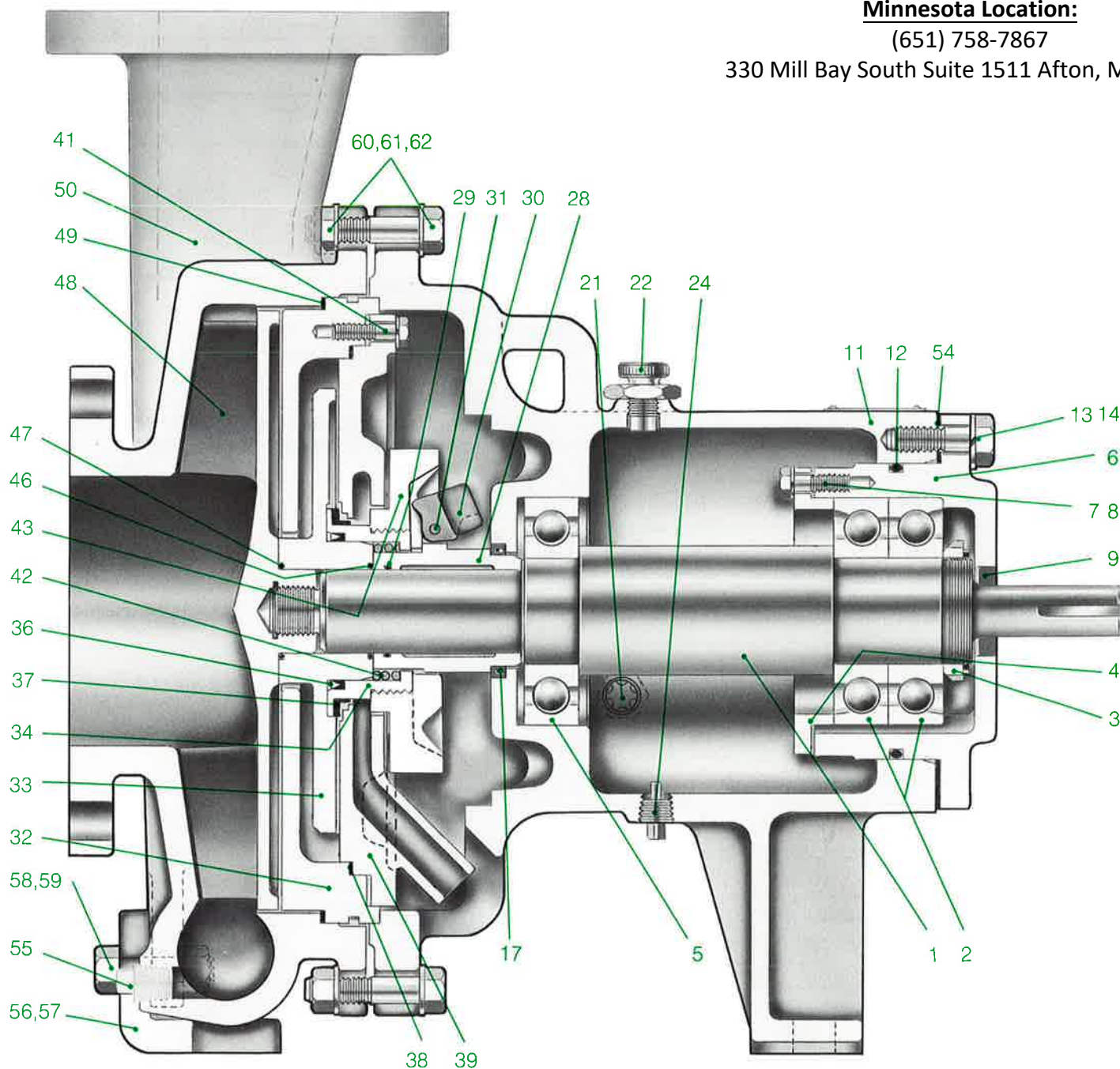

*These numbers refer to the size of the part. They may be obtained locally but special care must be taken to duplicate the original material. All other parts should be obtained from A. R. Wilfley and Sons.

Part numbers are listed in approximate order of assembly sequence.



Parts List and Recommended Spare Parts

Illinois Location:

(847) 841-7867
860 Church Rd Elgin, IL 60123

Minnesota Location:

(651) 758-7867
330 Mill Bay South Suite 1511 Afton, MN 55001

	#7000	#7100	#7300	#7400	#7450		
Item Number	Number Required	Spare Parts Kit	Shaft Assembly Kit	Seal Housing Kit	Pump Gasket Kit	Wet End Gasket Kit	Description
1	1		1				Shaft
2	2	2	2				Rear Bearing
3	1		1				Rear Bearing Locknut
4	1		1				Clamp Ring
5	1	1	1				Front Bearing
6	1						Bearing Retainer Housing
7	4						Clamp Ring Lockwasher
8	4						Clamp Ring Cap Screw (3/8-16 unc x 1-1/4)
9	1				1		Bearing Retainer Housing Oil Seal
11	1						Frame
12	1				1		Frame O-Ring (2-362)*
13	4						Bearing Retainer Housing Cap Screw (5/8-11 unc x 1-1/2)*
14	4						Bearing Retainer Housing Cap Screw Lock Washer
17	1				1		Front Bearing Oil Seal
21	1						Window Sight Glass
22	1						Oil Filler Plug
23	1						Closure Plate (not illustrated)
24	1						Oil Drain Plug
25	1						Oil Lubrication Plate (not illustrated)
26	1						Serial Number Plate (not illustrated)
27	12						Plate Drive Screw (not illustrated)
28	1						Governor Sleeve
29	1				1		Governor Sleeve O-Ring (2-134)*
30	2						Governor Weight
31	2						Governor Weight Pin
32	1	1		1			Case Plate
33	1	1		1			Expeller
34	1	1		1			Rotary Seal Housing
36	1			1	1	1	Rotary Seal Housing Seal
37	1	2		1			Rotary Seal Ring
38	1			1	1	1	Case Plate Gasket
39	1	1		1			Stationary Seal Ring Housing
41	10			10			Stationary Seal Ring Housing Cap Screw (3/8-16 unc x 1-1/4)*
42	1	1		1			Governor Spring
43	1			1			Actuator Body
46	1				1	1	Expeller O-Ring (2-134)*
47	1				1	1	Impeller O-Ring (2-134)*
48	1	1					Impeller
49	1				1	1	Case Gasket
50	1	1					Case
52	1						Rotation Plate (not illustrated)
54	1	1					Bearing Retainer Housing Shim (Set)
55							Case Drain Plug (optional)
56	1						Left Foot
57	1						Right Foot
58	2						Foot Attachment Bolt (1/2-13 unc x 1-1/2)*
59	2						Foot Attachment Nut
60	12						Case Bolt (5/8-11 unc x 2/1/2)*
61	12						Case Nut
62	24						Case Washer
63	1						Drain Hose (not illustrated)

Frame 4 Model AG Metal Pump

Illinois Location:

(847) 841-7867

860 Church Rd Elgin, IL 60123

Minnesota Location:

(651) 758-7867

330 Mill Bay South Suite 1511 Afton, MN 55001

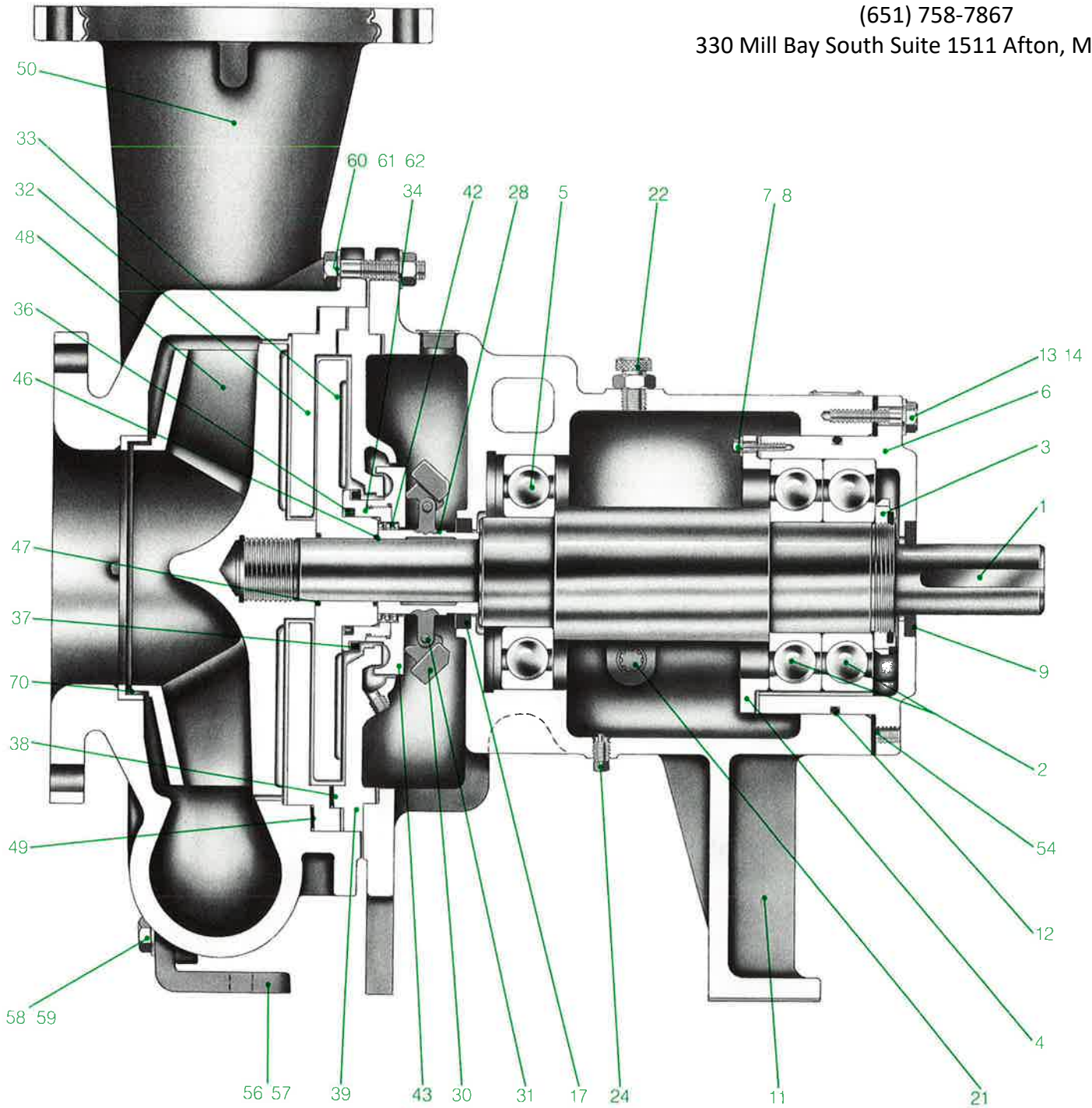



Parts List and Recommended Spare Parts

Illinois Location:

(847) 841-7867
860 Church Rd Elgin, IL 60123

Minnesota Location:

(651) 758-7867
330 Mill Bay South Suite 1511 Afton, MN 55001

	#7000	#7100	#7300	#7400	#7450		
Item Number	Number Required	Spare Parts Kit	Shaft Assembly Kit	Seal Housing Kit	Pump Gasket Kit	Wet End Gasket Kit	Description
1	1		1				Shaft
2	2	2	2				Rear Bearing
3	1		1				Rear Bearing Locknut
4	1		1				Clamp Ring
5	1	1	1				Front Bearing
6	1						Bearing Retainer Housing
7	4						Clamp Ring Lockwasher
8	4						Clamp Ring Cap Screw
9	1				1		Bearing Retainer Housing Oil Seal
11	1						Frame
12	1				1		Frame O-Ring
13	4						Bearing Retainer Housing Cap Screw
14	4						Bearing Retainer Housing Cap Screw Lock Washer
17	1				1		Front Bearing Oil Seal
21	1						Window Sight Glass
22	1						Oil Filler Plug
24	1						Oil Drain Plug
28	1						Governor Sleeve
30	2			1			Governor Weight
31	2						Governor Weight Pins
32	1	1		1			Case Plate
33	1	1		1			Expeller
34	1	1		1			Rotary Seal Housing
36	1			1	1	1	Rotary Seal Housing Seal
37	1	2		1			Rotary Seal Ring
38	1			1	1	1	Case Plate Gasket
39	1	1		1			Stationary Seal Ring Housing
42	1	1		1			Governor Spring
43	1			1			Actuator Body
46	1				1	1	Expeller O-Ring
47	1				1	1	Impeller O-Ring
48	1						Impeller
49	1						Case Gasket
50	1						Case
54	1		1				Bearing Retainer Housing Shim (Set)
56	1						Left Foot
57	1						Right Foot
58	2						Foot Bolt
59	2						Foot Nut
60	12						Case Bolt
61	12						Case Nut
62	24						Case Washer
70	1						Case Wear Ring

Frame 1 & 2 Non-Metallic

Important:
Please insure that pump and pipe flanges are aligned. Mis-alignment will cause a sideways deflection of the flange liner which may result in leakage between the liner and the metal case shell. The flange liner is self centering.

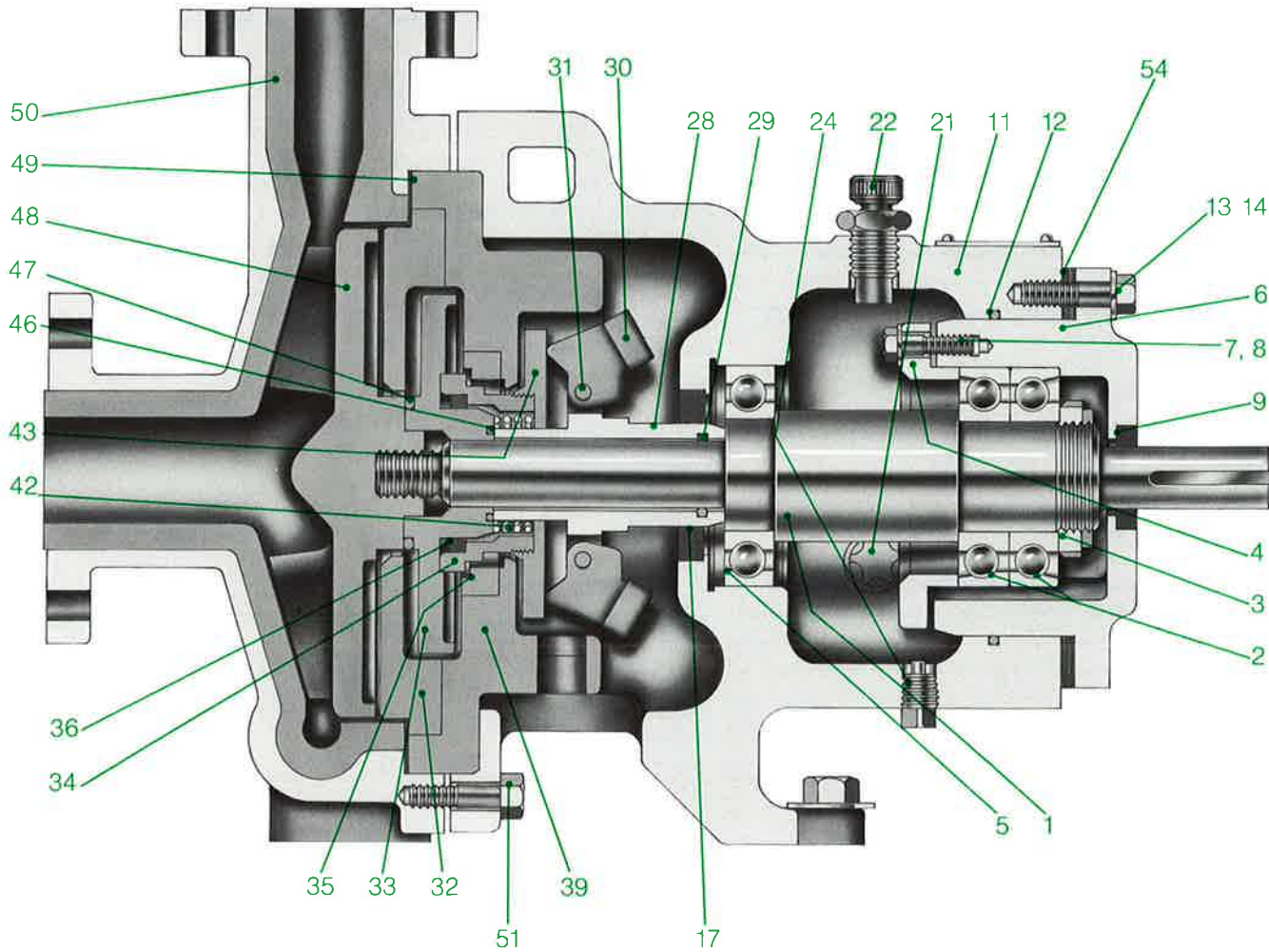
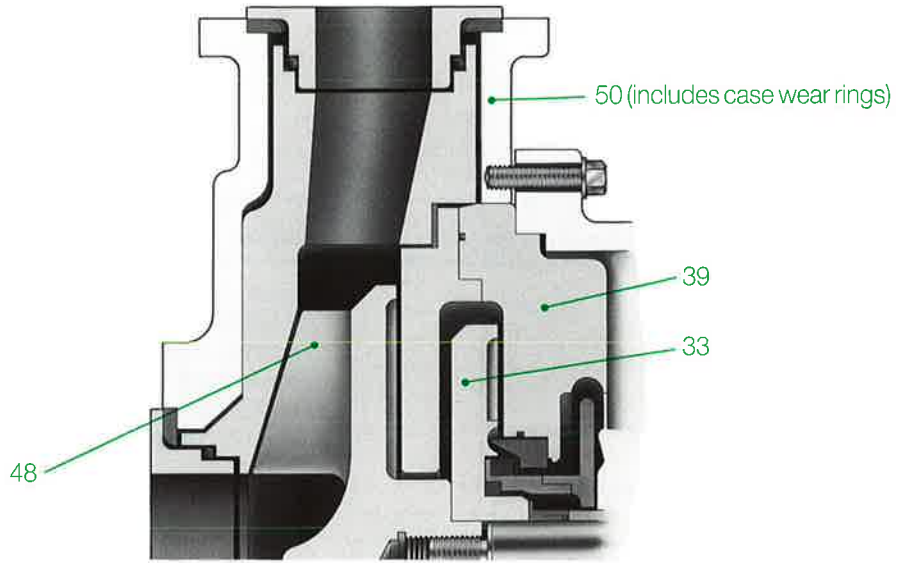



Parts List and Recommended Spare Parts

Illinois Location:

(847) 841-7867

860 Church Rd Elgin, IL 60123

Minnesota Location:

(651) 758-7867

330 Mill Bay South Suite 1511 Afton, MN 55001

	#7000	#7100	#7300	#7400	#7450		
Item Number	Number Required	Spare Parts Kit	Shaft Assembly Kit	Seal Housing Kit	Pump Gasket Kit	Wet End Gasket Kit	Description
1	1		1				Shaft
2	2	2	2				Rear Bearing
3	1		1				Rear Bearing Locknut
4	1		1				Clamp Ring
5	1	1	1				Front Bearing
6	1						Bearing Retainer Housing
7	4						Clamp Ring Lockwasher
8	4						Clamp Ring Cap Screw
9	1				1		Bearing Retainer Housing Oil Seal
11	1						Frame
12	1				1		Frame O-Ring (2-157)*
13	4						Bearing Retainer Housing Cap Screw
14	4						Bearing Retainer Housing Cap Screw Lock Washer
17	1				1		Front Bearing Oil Seal
21	1						Window Sight Glass
22	1						Oil Filler Plug
23	1						Closure Plate (not illustrated)
24	1						Oil Drain Plug
25	1						Oil Lubrication Plate (not illustrated)
26	1						Serial Number Plate (not illustrated)
27	12						Plate Drive Screw (not illustrated)
28	1						Governor Sleeve
29	1				1		Governor Sleeve O-Ring
30	2						Governor Weight
31	2						Governor Weight Pin
32	1	1		1			Rear Case Plate
33	1	1		1			Expeller
34	1	2		1			Rotary Seal Housing
35	1	2		1			Stationary Seal Ring
36	1		1	1		1	Rotary Seal Housing Seal
39	1	1		1			Stationary Seal Ring Housing
42	1	1		1			Governor Spring
43	1			1			Actuator Body
46	1				1	1	Expeller O-Ring
47	1				1	1	Impeller Seal
48	1	1					Impeller
49	1				1	1	Case Gasket
50	1						Case Assembly
51	8						Case Cap Screw
52	1						Rotation Plate (not illustrated)
54	1	1					Bearing Retainer Housing Shim (Set)



Pump System Troubleshooting

Problem	Test	Test Results	Indicates	Action to Take
No Flow or Low Flow	1 Rotate motor shaft by hand.	Rotates freely		Proceed to number 3
		Shaft won't turn, or rubbing noise.	Pump or motor failure.	Proceed to number 2
	2 Remove coupling, rotate motor and pump shafts by hand.	Pump shaft won't turn.	Pump Problem.	Remove pump & repair. Proceed to number 3
		Motor shaft won't turn.	Motor bearing problem.	Replace motor. Proceed to number 3
	3 Start motor, check direction of rotation.	Rotation correct.	Motor wiring reversed.	Proceed to number 4
		Rotation incorrect.		Correct hookup.
	4 Check pump shaft speed.	Pump speed OK.		Proceed to number 6
		Pump speed incorrect.		Proceed to number 5
	5 If pump gearbox or v-belt driven-check motor speed.	Motor speed OK.	Sheaves or gear ratio wrong.	Correct speed ratio.
		Motor speed incorrect.	Wrong speed motor or low voltage.	Correct as required.
	6 Install pressure gauges at pump inlet and discharge-pump not running.	Inlet pressure OK.		Proceed to number 7
		Inlet pressure low or missing.	Inlet valve closed or blocked.	Open valve or free blockage. Proceed to number 7
	7 Start pump and motor-check inlet pressure.	Inlet pressure OK.		Proceed to number 8
		No inlet pressure.	Unit cavitating or not primed.	Bleed pump case. Check valves and piping.
		Low inlet pressure.	Inlet line restricted or air leaks in inlet piping, excessive vapors (low NPSH), foaming of fluid.	Use defoamer, eliminate air leaks. Correct NPSH problems.
	8 Check discharge pressure and compare with head-flow curve.	Pressure at pump OK.	Faulty flow instrumentation.	Proceed to number 9
		Pressure higher than normal.	Discharge valve or piping blocked.	Correct blockage.
		Pressure lower than normal.	Excessive impeller clearance or impeller damage. (Could indicate excessive pump flow & delivery. Proceed to number 9.)	Remove pump & repair.
	9 Check flow instrumentation vs. physical Measurement.	Measurements do not correspond	Instrumentation Error	Check valving, instrumentation and piping



Pump System Troubleshooting

Problem	Test	Test Results	Indicates	Action to Take
Noise & or Vibration	1 Visually check for loose or missing screws or bolts from coupling or tie-down points.	Bolt and screws OK.	Improper or incomplete assembly	Proceed to number 2
		Loose or missing bolts.		Replace and tighten bolts
	2 Rotate unit by hand.	Unit free and clear. Scraping, clunking or other unusual noise heard.		Proceed to number 3 Proceed to number 4
		or Unit won't turn free & easily.		Proceed to number 4
	3 With unit running, monitor type & location of noise. Use stethoscope or screwdriver held against pump & motor housing over bearings.	Grinding, scraping, rubbing noise heard from pump only.	Impeller or expellers rubbing inside case.	Remove & repair. Check clearances.
		Scraping or rubbing noise heard from motor only.	Possibly motor fan blades loose or bent.	Consult motor manual.
		Thumping or clicking noise or excessive vibration.	Bad bearings, damaged coupling or pump/motor misalignment.	Proceed to number 4
	4 Drop drive coupling. Push & pull pump & motor shafts in both radial & axial direction.	No shaft movements observed.	Bearing OK	Proceed to number 5
		Shaft wiggles or moves.	Failed bearings.	Remove & repair. Proceed to number 6
	5 With coupling removed, turn on motor and listen for noise.	Motor quiet.		Proceed to number 6
		Noisy	Motor failure	Remove & Replace
	6 Check pump and motor shaft alignment with dial indicator.	Axial alignment & squareness within .005-inch.	Correct alignment	Proceed to number 7
		Axial alignment & squareness not within .005-inch.	Poor alignment	Align units.
	7 Remove pump frame oil drain plug. Check for metallic particles on drain plug magnet.	No metal chips or particles found	Bearing OK	Recheck tests.
		Metallic chips or particles found.	Bearing failure.	Remove pump & repair.



Pump System Troubleshooting

Problem	Test	Test Results	Indicates	Action to Take
Motor Runs Hot or Throws Breaker	1 With motor & pump not running, verify units rotate freely by hand without noise or drag.	Shaft turns freely-no noise	Mechanical Problem	Proceed to number 2
		Shaft drag or noise heard		Go to section on noise & vibration #1
	2 Check breaker fuse size and motor nameplate rating.	Breaker fuse and motor rating correspond	Correct motor & fuse	Proceed to number 3
		Breaker fuse and motor rating do not correspond	Incorrect fuse	Install proper fuse
	3 With motor & pump running, check pump & motor speed.	Speed & motor direction OK	Correct motor & frequency	Proceed to number 4
		Speed of pump wrong	Incorrect motor or frequency.	Correct motor
	4 Measure pump output flow rate and/or discharge pressure	Flow and pressure correct		Proceed to number 5
		Flow too high (discharge pressure low)	Improper valving or system upset.	Correct system problems.
	5 Measure motor amperage or HP.	Amperage (HP) ok.		Proceed to number 6
		Amperage (HP) too high.	Mechanical failure of pump or motor.	Go to section on noise & vibration #1
	6 Measure motor voltage at motor and breaker.	Motor voltage ok		Proceed to number 7
		Motor voltage low	Incorrect voltage	Correct voltage
	7 Check motor fan cooling & air flow.	Good air flow, cool temperature.	Motor Problem.	Consult Motor Manual.
		No air flow.	Motor fan difficulty or shroud blocked.	Improve air flow, consult Motor Manual.



Illinois Location:

(847) 841-7867

860 Church Rd Elgin, IL 60123

Minnesota Location:

(651) 758-7867

330 Mill Bay South Suite 1511 Afton, MN 55001

PumpSupplyInc.com



Pump System Troubleshooting

Problem	Test	Test Results	Indicates	Action to Take	
<p>Whenever leakage is encountered, before removing pump, visually determine when the leakage is occurring, while running, during coast down or when the pump is at a full stop. During these inspections you should try to determine the exact origin of the leak. Special attention should be given to the drain spout, which can be observed with an angled mirror. Once you have determined when the pump is leaking, refer to the guide below.</p>					
Leakage (normal running)	1	Visually determine exact leakage point.	Leakage is down inside of drain spout.	<p>Pump inlet pressure exceeds expeller capacity.</p> <p>Excessive expeller wear corrosion, or clearance.</p>	<p>Check inlet pressure.</p> <p>Remove pump and use Disassembly Guide for Leakage. Section B.</p>
			Leakage comes from case or gasket area.	Damaged seal surface, gasket failure, or loose bolts.	Remove pump and use Disassembly Guide for Leakage. Section C.
Leakage (coast down or at start up)	1	Visually determine exact leakage point.	Leakage is from drain spout or frame opening.	<p>Pump inlet pressure problems.</p> <p>Problem with check valve assembly.</p>	<p>Check shut down procedure, page 4</p> <p>Remove pump and use Disassembly Guide for Leakage. Section A.</p>
			Leakage is from case or gasket area.	Damaged seal surface, gasket failure or loose bolts.	Remove pump and use Disassembly Guide for Leakage. Section C.
Leakage (pump at complete stop)	1	Visually determine exact leakage point.	Leakage is down inside of drain spout.	Problem with check valve assembly.	Remove pump and use Disassembly Guide for Leakage. Section A.
			Leakage is from case or gasket area.	Damaged seal surface, gasket failure, or loose bolts.	Remove pump and use Disassembly Guide for Leakage. Section C.

Disassembly Guide for Leakage

A. Check Valve Assembly Malfunction

Parts Involved:
 Rotary seal ring
 Rotary housing
 Stationary seal ring housing
 Rotary housing seal
 Governor weights and pins
 Governor sleeve
 Governor spring
 Actuator body
 Expeller (hub)

Disassembly Checks

1. Remove case and impeller, and case plate assembly.
2. Check governor weights for wear, freedom of movement and size.

3. Place case plate assembly face down on bench. Check spring action of actuator body by pushing down and quickly releasing.
4. Complete disassembly and check internal part conditions.

B. Expeller System Malfunction

Parts Involved:
 Impeller
 Case Plate
 Expeller
 Stationary seal ring housing

Disassembly Checks

1. Remove case and check expeller to case plate clearance.
2. Complete disassembly and check component condition.

C. Gasket or seal surface malfunction

Parts Involved:
 Case
 Case gasket
 Case bolts
 Case plate gasket
 Case plate
 Stationary seal housing
 Case plate bolts

Disassembly Checks

1. Check case bolt tightness and condition during removal.
2. Check case plate bolt tightness and condition.
3. Complete disassembly and check component condition of listed parts for tearing, corrosion, wear and rubbing.



Spare Parts Ordering

Please include the serial number of your pump when ordering spare parts. With this number we can duplicate the original configuration and materials of your pump.

To make part ordering easier, we have preassembled the replacement kits listed below and on the parts list. These kits are assembled to match your pump.

#7000

Recommended Spare Parts Kit:

Except for gaskets, this kit contains the parts we recommend you have on hand to provide proper maintenance for your pump. Several gasket kits, #7400 and #7450 should also be ordered. The spare parts kit is designed for one pump and should be altered when ordering stock for two or more pumps. The actual quantity of spare parts needed for a safe stock can be somewhat more or less depending on the severity of your pumping conditions.

#7100

Shaft and Bearing Assembly Kit:

Shaft and bearings are preassembled and are ready for installation.

#7300

Seal Housing Assembly Kit:

This kit contains a fully assembled seal housing assembly, the unit needs only to be installed in your pump.

#7400

Gasket and O-Ring Kit:

(Entire pump)

#7450

Gasket and O-Ring Kit:

(Wetted end only)

These kits supply all the gaskets and o-rings that you will need when re-assembling your pump. Several of these kits should be kept on hand.

Special Service

The seal housing assembly is extremely important to the total, efficient operation of the Wilfley AG pumps. Its parts, gaskets and seals must be in good working order. Many times parts are replaced unnecessarily due to the unfamiliarity with the assembly. The reverse is also true, parts that should be replaced are at times left in the assembly. For these reasons we provide the service of rebuilding this assembly in our factory.

Each assembly is thoroughly inspected upon arrival. The tolerances and condition of each part is checked and only the parts that don't meet test requirements are replaced. The assembly is then fitted with gaskets and reassembled. We include all pump gaskets and o-rings that you will need to reinstall this unit, including gaskets for the case and case plate, and o-rings for the expeller, impeller and governor sleeve. We charge the standard price for parts and a minimal reassembly fee.

The utilization of this service provides you with almost instantaneous pump seal housing assembly repair at an economical price. The units are overhauled and returned to you quickly. Wilfley provides a special carton for easy mailing. You simply stock this assembly as a single spare part and let us do the rebuilding.

Please contact A.R. Wilfley and Sons or any of our representatives at any time, concerning our pumps or parts. You can be assured that we will do all we can to ensure your complete satisfaction with Wilfley products.

Your Wilfley AG pumps may be returned to the factory, at any time, for complete overhaul and repair. Each pump is completely disassembled and worn or inoperable parts are replaced. All rebuilt pumps are subjected to the same testing procedures as newly constructed units.

For additional information and ordering parts contact:

A.R. Wilfley and Sons, Inc.
P.O. Box 2330
Denver, Colorado 80201
1-303-779-1777
1-800-525-9930



Illinois Location:

(847) 841-7867

860 Church Rd Elgin, IL 60123

Minnesota Location:

(651) 758-7867

330 Mill Bay South Suite 1511 Afton, MN 55001

PumpSupplyInc.com