

**Wilfley**

**Centrifugal  
ANSI B73.1  
Acid Pump**

# Technical Handbook

**Model AG**



**WILFLEY**

## Wilfley AG ANSI B73.1 Pumps

The Wilfley Model AG is an end-suction, single stage, sealless (no packing, water glands or conventional mechanical seals) centrifugal pump. It handles solutions that are highly corrosive and abrasive. Discharge sizes range from 1" to 8" in diameter. Flow rates range from 10 gallons per minute to 3,000 per minute.

### Sealless Operation

All Wilfley Model AG pumps are manufactured without using packing, water glands or conventional mechanical seals. To prevent leaking while running, AG pumps have a secondary impeller, the original Wilfley expeller, which creates a hydraulic seal. This hydraulic seal keeps the solution away from the shaft while the pump is operating. The impeller and expeller rotate together during operation.

Static seal faces prevent leakage when the pump is shut down. The pump remains leak free while running and while shut down.

Wilfley pumps can be run dry without damaging internal parts because wetted parts operate freely with no rubbing contact. Constant down time to repair and replace conventional contact seals is eliminated. Parts for all Wilfley pumps are designed for quick interchangeability resulting in minimum repair time.

### Quality Control

Wilfley Model AG pumps are thoroughly tested and inspected throughout each phase of production. All parts are 100% inspected during manufacturing and assembly. Cases are pressure tested to ensure strength and durability. Every AG pump is placed on a test rack and operated to the exact performance specified.

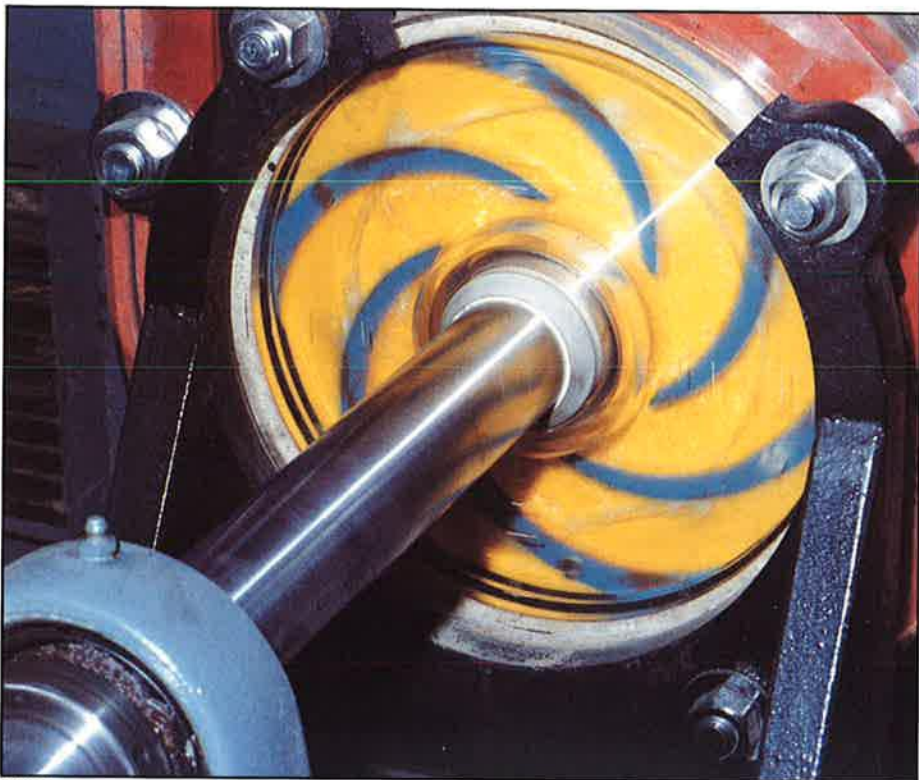

Wilfley hydraulic seal in actual operation.

The Wilfley organization is proud of the individual engineering service traditionally provided to customers. Each pump is made to perform to exact specifications. Wilfley also extends the same engineering service at no charge whenever pumping conditions are changed.

### Materials

A.R. Wilfley and Sons produces AG centrifugal pumps from many materials. Wilfley can provide pumps with special combinations of alloys and non-metallic materials. Wilfley's engineering staff has

the expertise and experience to make material recommendations. To assist material selection, Wilfley maintains an extensive library of pump services and corrosion/abrasive data. Wilfley is continually testing the effects of both abrasion and corrosion on a wide variety of materials.

Many types of stainless steel are used in the manufacture of Wilfley AG Pumps. The most common are Alloy 20 (CN7M), 316 (CF8M) and CD4MCu. Other alloys are available.



Many non-metallic materials are available in Wilfley Model AG pumps including carbon-filled polysulfone and Tefzel®. Wilfley's proprietary materials can be used for case construction including W-30, a modified phenol formaldehyde resin, and W-50, a modified furfural ketone resin.

**Special Modifications**

A.R. Wilfley & Sons is dedicated to providing pumps that maximize their full potential. Wilfley routinely accommodates customer requests for steam jackets, special paint, flush ports, special drain plugs and other modifications required to fit specific needs. Many applications require special motor and drive configurations, including subbases and mounting brackets. Non-metallic subbases are available. Wilfley engineers assist in any special configuration that the solution and process require. Wilfley's famous high-quality workmanship applies to all special modifications.

**Product Line**

Wilfley manufactures a wide range of centrifugal pumps for both the chemical processing and mining industries. Wilfley pumps are available to handle highly abrasive slurries containing large particles, as well as non-ANSI acid pumps to handle corrosive materials. Wilfley's applications and sales engineering staff provide the most up-to-date information and technology on pumps and pump processes.

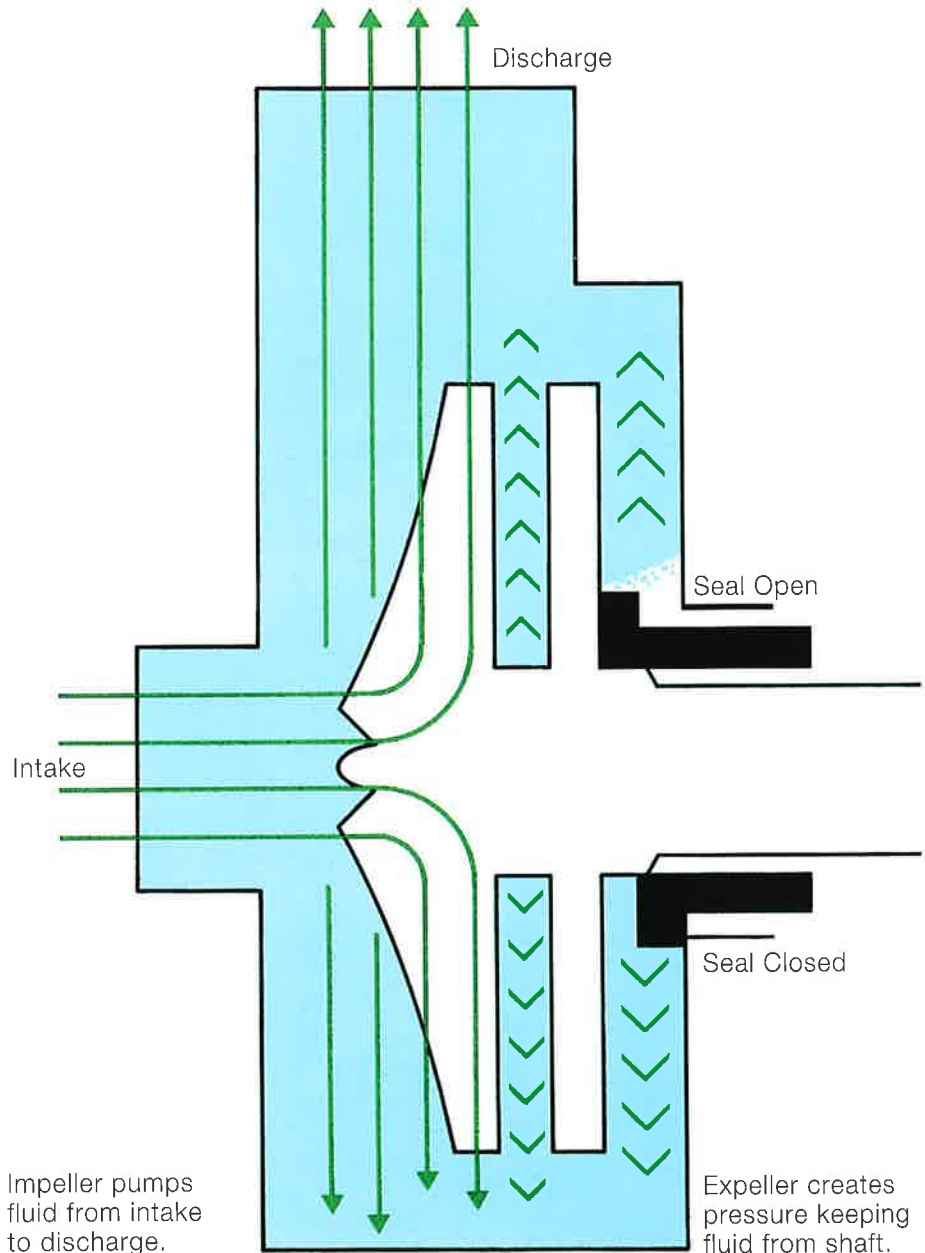

Impeller pumps fluid from intake to discharge.

Expeller creates pressure keeping fluid from shaft.



**Illinois Location:**

(847) 841-7867

860 Church Rd Elgin, IL 60123

**Minnesota Location:**

(651) 758-7867

330 Mill Bay South Suite 1511 Afton, MN 55001

PumpSupplyInc.com



## Wilfley AG ANSI B73.1 Pumps

The centrifugally operated governor weights provide smooth and efficient seal opening and closing. The frame provides a guard to isolate all moving parts.

The extra case wall thickness and unique design extends wear life.

Rotary and stationary seal faces are open during operation and closed to prevent leakage when the pump is shut down. Parts tinted in green move forward to open seal faces when the pump is started.

Large impeller vanes provide highly efficient pumping with long wear life.

The double Wilfley expeller provides a positive hydraulic sealing arrangement eliminating packing, water glands and mechanical seals.

Cast case feet.

The subbase and frame are heavy cast iron and made to withstand stresses with heavy rib reinforcements. Non-metallic subbases are available.

The governor sleeve protects the shaft from liquid contact.

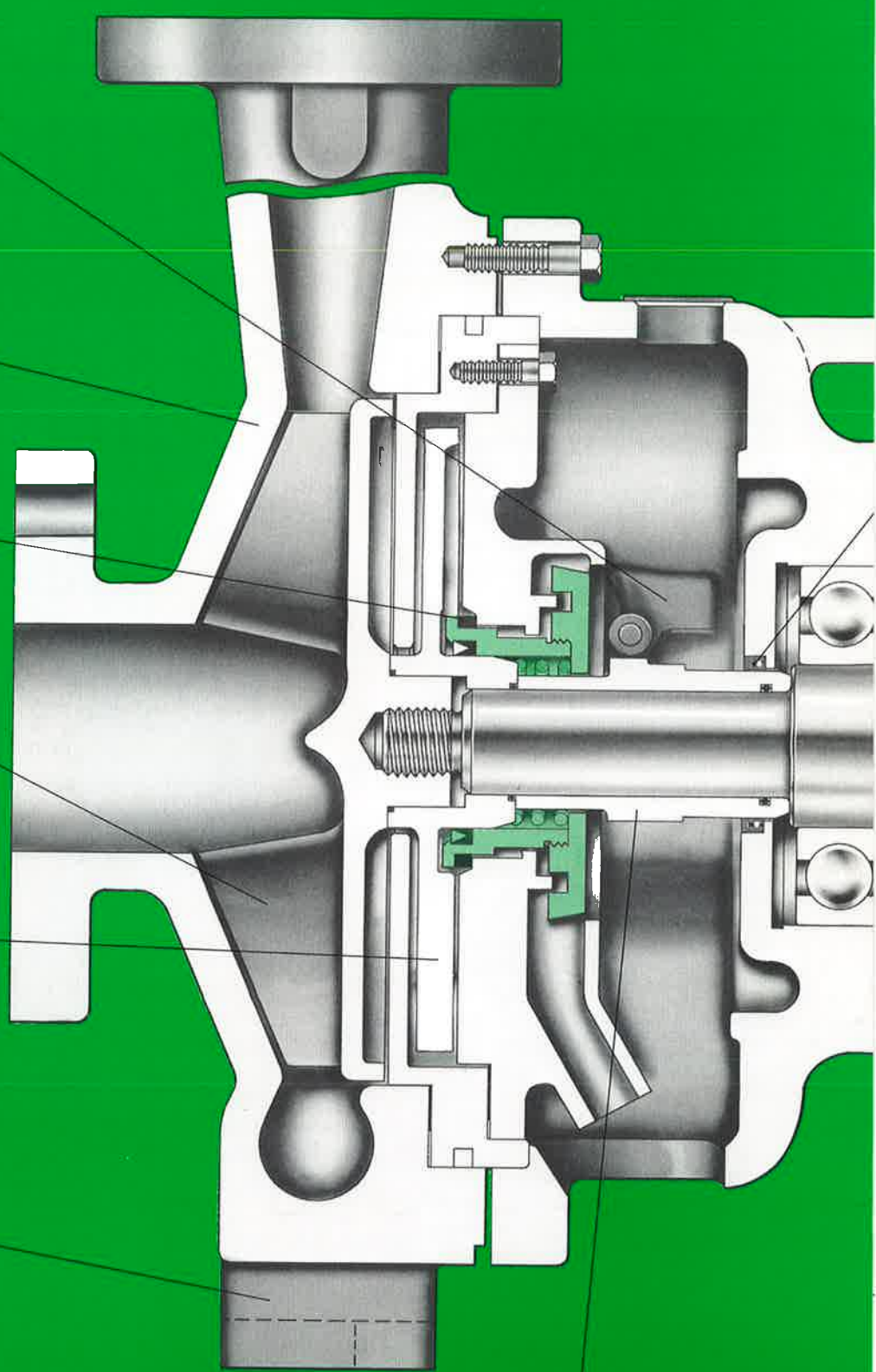

Replaceable front bearing seals protect bearings from contamination.

Shafts are made of extra strength high quality steel.

Extra large bearings provide a long durable life.

The large oil reservoir in the frame is available with sight glass or optional constant level oiler.

**WILFLEY**



# AG ANSI B73.1 Pump Capacities

## 3550 RPM

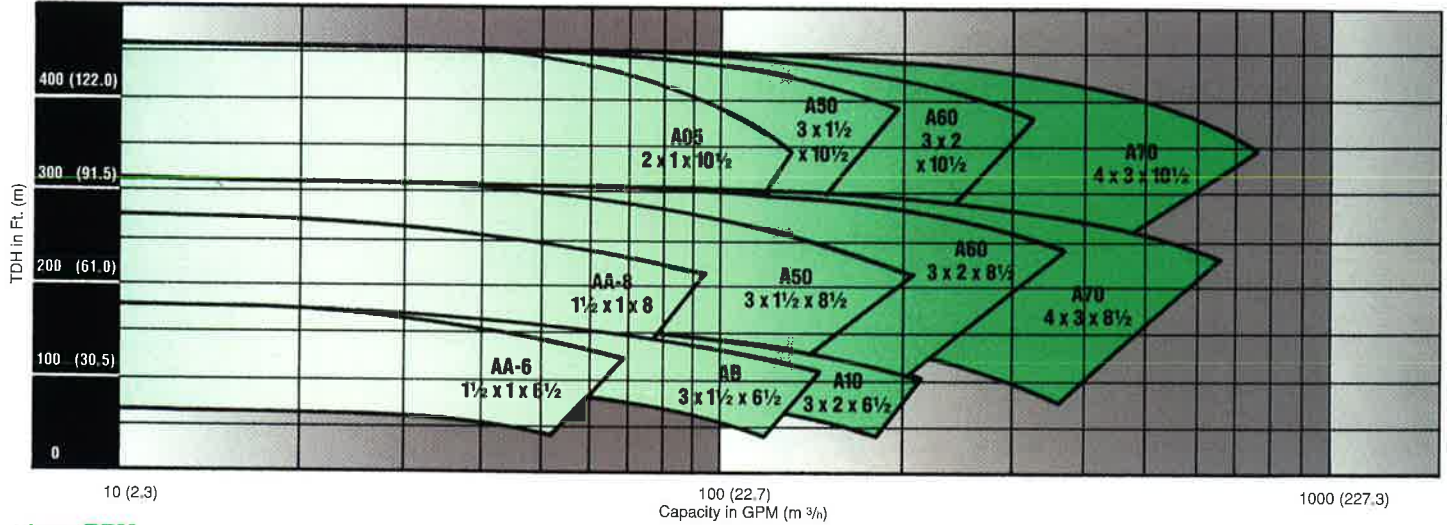

## 1750 RPM

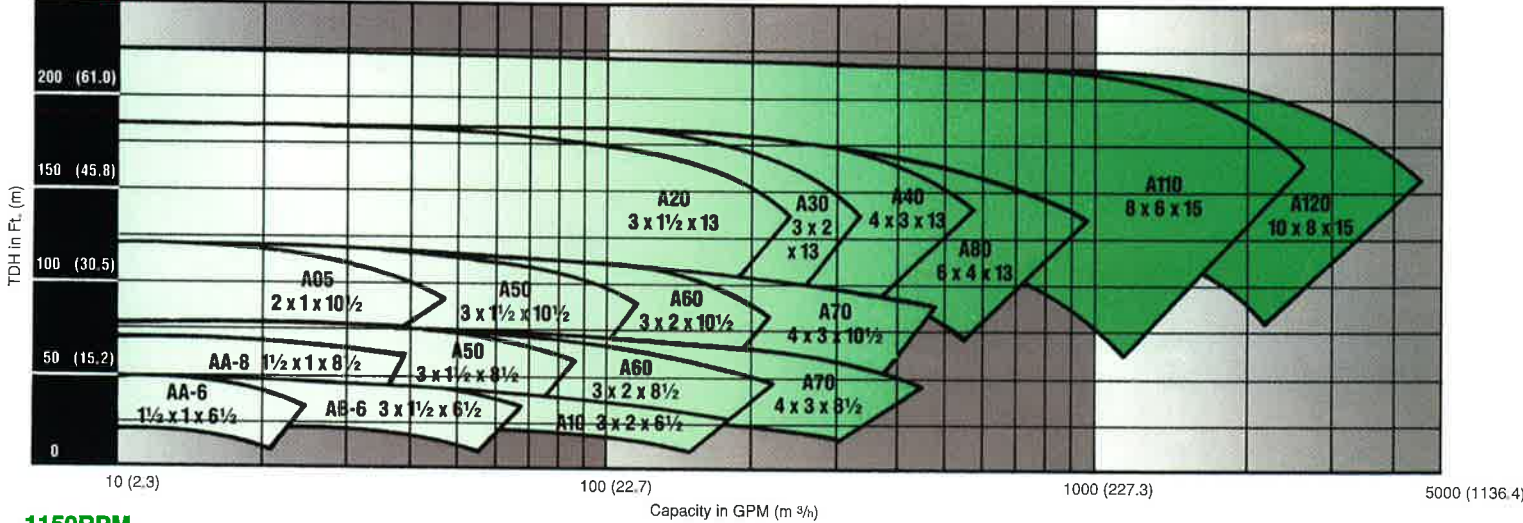

## 1150 RPM

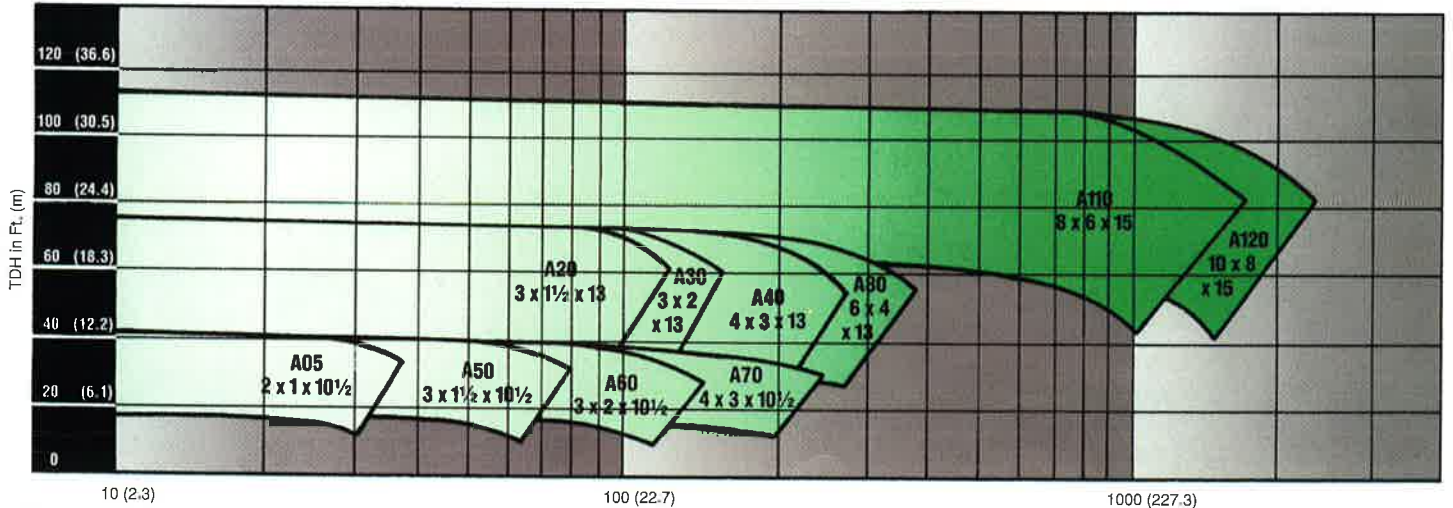





## Frame 1 and 2

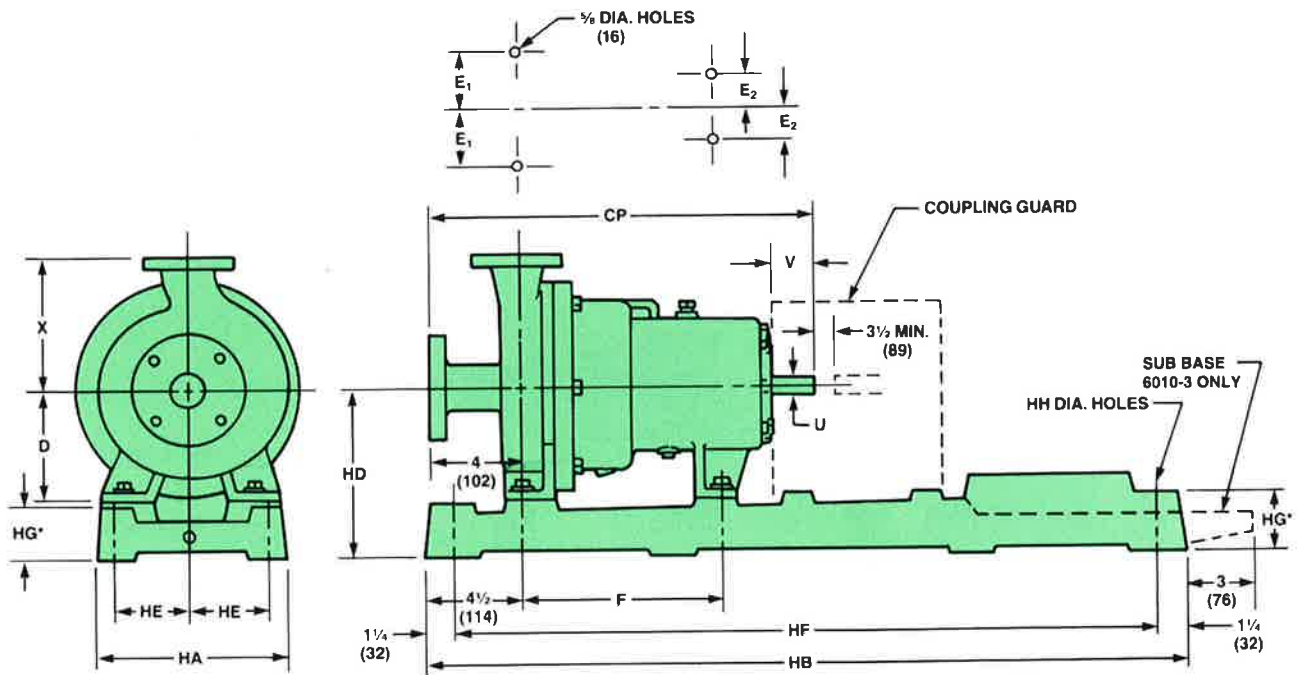

FRAME	ANSI	SIZE	CP	D	2 E <sub>1</sub>	2 E <sub>2</sub>	F	U		V (MIN.)	X
								DIA.	KEYWAY		
1	AA-6 AA-8	1 1/2 x 1 (40 x 25)	17 1/2 (445)	5 1/4 (133)	6 (152)	0	7 1/4 (184)	7/8 (22.23)	3/16 x 3/32 (4.76 x 2.38)	2 (51)	6 1/2 (165)
	AB-6	3 x 1 1/2 (80 x 40)									
2	A05-10	2 x 1 (50 x 25)	23 1/2 (597)	8 1/4 (210)	9 3/4 (248)	7 1/4 (184)	12 1/2 (318)	1 1/8 (28.58)	1/4 x 1/8 (6.35 x 3.18)	2 5/8 (67)	8 1/2 (216)
	A10-6	3 x 2 (80 x 50)									8 1/4 (210)
	A50-8 A50-10	3 x 1 1/2 (80 x 40)									8 1/2 (216)
	A60-8 A60-10	3 x 2 (80 x 50)									9 1/2 (242)
	A70-8 A70-10	4 x 3 (100 x 80)									11 (280)

FRAME	SUBBASE SIZE		MOTOR FRAME RANGE		HA	HB	HD		HE	HF	HG*	HH
	WILFLEY	ANSI	T	U			D 5 1/4 (113)	D 8 1/4 (210)				
1	6010-1	IT	143T	182	10 (254)	35 (890)	8 1/4 (210)		4 (102)	32 1/2 (825)	2 7/8 (73)	3/4 (19)
			182T	184								
	6010-2	2T	184T	213	12 (305)	39 (990)			8 1/2 (216)	4 1/2 (114)	36 1/2 (900)	
2	6010-3	N.A.	254T	254U	12 (305)	45 (1140)	12 (305)		4 1/2 (114)	42 1/2 (1080)	3 5/8 (92)	3/4 (19)
			286TS	284U								
			6010-4	1								
6010-5	2	254T	254U	18 (467)	58 (1475)	13 (330)	7 1/2 (191)	55 1/2 (1410)	4 (102)	1 (25)		
6010-6	3	324TS	324S									

\*Fabricated subbase "HG" is 3/8" when used to establish foundation bolt length except for 6010-3, which is 3/4".

Dimensions shown are not for construction unless certified. Dimensions are shown in inches and (approximate equivalent millimeters). All flanges same as 150 lbs. American Standard Cast Steel.

Field shimming by customer may be required to meet maximum ANSI B73.1 HD dimensions. Subbase dimensions are for cast iron or steel, fabricated or non-metallic designs.



Frame 3 and 4

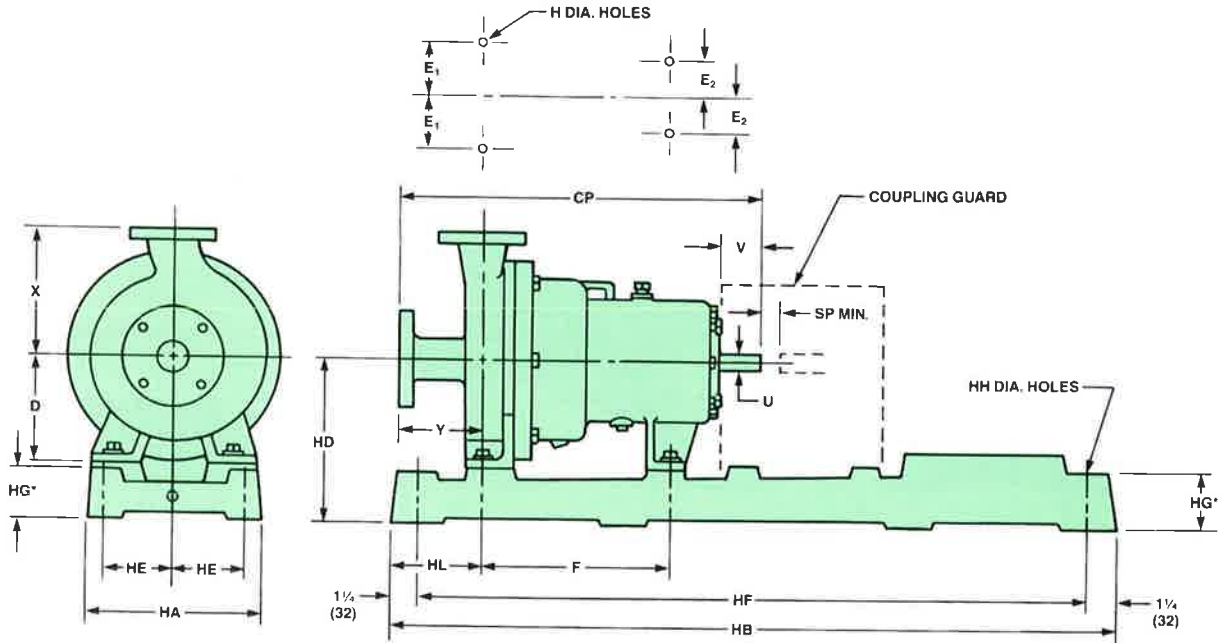

FRAME	ANSI	SIZE	CP	D	2 E <sub>1</sub>	2 E <sub>2</sub>	F	U		V MIN.	X	Y	H
								DIA.	KEYWAY				
3	A20-13	3 x 1 1/2 (80 x 40)	23 1/2 (597)	10 (254)	9 3/4 (248)	7 1/4 (184)	12 1/2 (318)	1 1/8 (28.58)	1/4 x 1/8 (6.35 x 3.18)	2 5/8 (67)	10 1/2 (266)	4 (102)	5/8 (16)
	A30-13	3 x 2 (80 x 50)									11 1/2 (292)		
	A40-13	4 x 3 (100 x 80)									12 1/2 (318)		
	A80-13	6 x 4 (150 x 100)									13 1/2 (343)		
4	A110-15	8 x 6 (200 x 150)	33 7/8 (860)	14 1/2 (368)	16 (406)	9 (229)	18 3/4 (476)	2 3/8 (60.33)	5/8 x 5/16 (15.88 x 7.94)	4 1/2 (114)	18 (457)	6 (152)	3/4 (19)
	A120-15	10 x 8 (250 x 200)									19 (483)		

FRAME	SUBBASE SIZE		MOTOR FRAME RANGE		HA	HB	HD	HE	HF	HG*	HH	HL	SP
	WILFLEY	ANSI	T	U									
3	6010-4	1	143T 215T	182 215	12 (305)	45 (1140)	13 3/4 (349)	4 1/2 (114)	42 1/2 (1080)	3 5/8 (92)	3/4 (19)	4 1/2 (114)	3 1/2 (89)
	6010-5	2	254T 326TS	254U 286U	15 (391)	52 (1320)	14 1/8 (359)	6 (152)	49 1/2 (1260)	3 3/4 (95)			
	6010-6	3	326T 444TS	324U 444US	18 (467)	58 (1475)	14 3/4 (375)	7 1/2 (191)	55 1/2 (1410)	4 (102)			
4	6010-8**	5	256T 365T	256U 365U	22 (559)	68 (1730)	19 (483)	9 1/2 (241)	65 1/2 (1664)	7/8 (22)	1 (25)	6 1/2 (165)	5 1/4 (133)
	6010-9**	6	404T 444T	444U 445U		80 (2032)	19 1/4 (489)		77 1/2 (1968)	5/8 (16)			

\*Fabricated subbase "HG" is 3/8" when used to establish foundation bolt length for Frame 3 pumps.  
 \*\*Fabricated subbase only.

Dimensions shown are not for construction unless certified.  
 Dimensions are shown in inches and (approximate equivalent millimeters).  
 All flanges same as 150 lbs. American Standard Cast Steel.

Field shimming by customer may be required to meet maximum ANSI B73.1 HD dimensions.  
 Subbase dimensions are for cast iron or steel, fabricated or non-metallic designs.





## Frame 1 Overhead V-Belt Drive

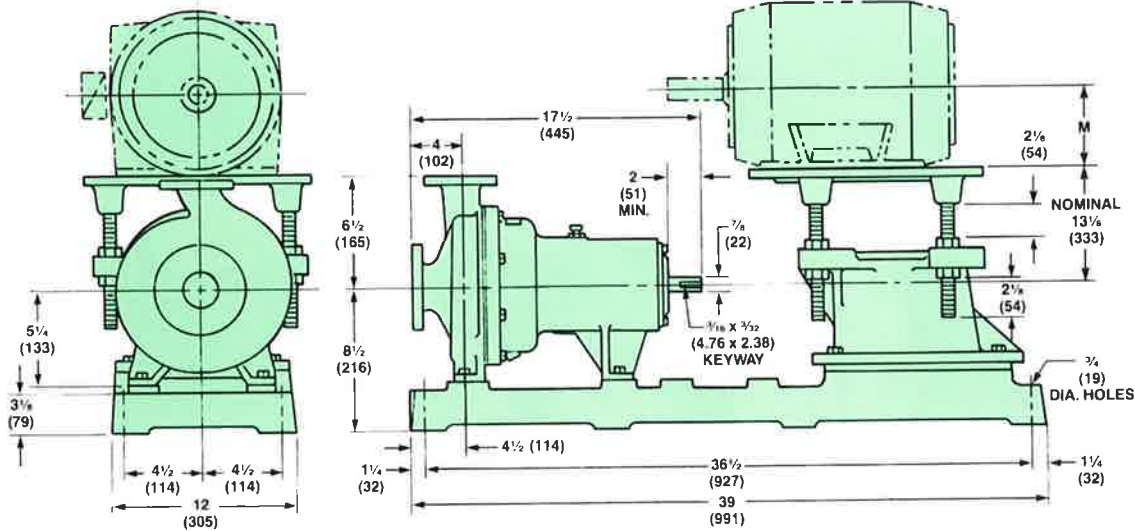

ANSI	SIZE	MOTOR FRAME RANGE	M
AA-6	1 1/2 x 1 (40 x 25)	143T - 145T	3 1/2 (89)
AA-8	1 1/2 x 1 (40 x 25)	182T - 184T	4 1/2 (114)
AB-6	3 x 1 1/2 (80 x 40)	213T - 215T	5 1/4 (133)



### Illinois Location:

(847) 841-7867

860 Church Rd Elgin, IL 60123

### Minnesota Location:

(651) 758-7867

330 Mill Bay South Suite 1511 Afton, MN 55001

PumpSupplyInc.com

Dimensions shown are not for construction unless certified.  
Dimensions are shown in inches and (approximate equivalent millimeters).  
All flanges same as 150 lbs. American Standard Cast Steel.

Field shimming by customer may be required to meet maximum ANSI B73.1 HD dimensions.  
Subbase dimensions are for cast iron or steel, fabricated or design.



## Frame 2 and 3 Overhead V-Belt Drive

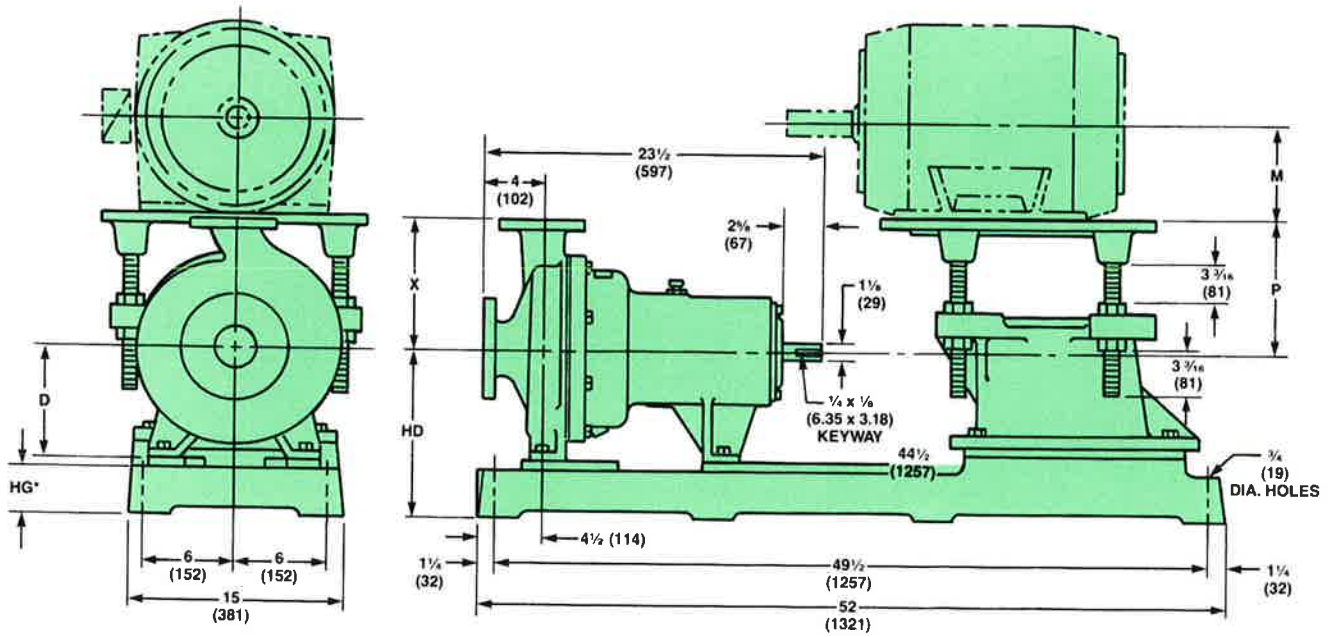

FRAME	ANSI	SIZE	D	X	HD		HG*	MOTOR FRAME RANGE	M	P (NOM.)	
					D 8 1/4 (210)	D 10 (254)				D 8 1/4 (210)	D 10 (254)
2	A10-6	3 x 2 (80 x 50)	8 1/4 (210)	8 1/4 (210)	12 3/8 (314)	14 1/8 (359)	3 3/4 (95)	254T - 256T	6 1/4 (159)	10 5/16 (262)	8 9/16 (217)
	A50-8	3 x 1 1/2		8 1/2 (216)				254U - 256U			
	A60-8	3 x 2 (80 x 50)		9 1/2 (242)				284T - 286T	7 (178)		
	A70-8	4 x 3 (100 x 80)		11 (280)				284U - 286U			
	A05-10	2 x 1 (50 x 25)		8 1/2 (216)				324T - 326T	8 (203)		
	A50-10	3 x 1 1/2 (80 x 40)		9 1/2 (242)				324U - 326U			
	A60-10	3 x 2 (80 x 50)		11 (280)				364T - 365T	9 (229)		
	A70-10	4 x 3 (100 x 80)		11 (280)				364U - 365U			
3	A20-13	3 x 1 1/2 (80 x 40)	10 (254)	10 1/2 (266)	12 3/8 (314)	14 1/8 (359)	3 3/4 (95)	404T - 405T	10 (254)		
	A30-13	3 x 2 (80 x 50)		11 1/2 (292)				404U - 405U			
	A40-13	4 x 3 (100 x 80)		12 1/2 (318)							
	A80-13	6 x 4 (150 x 100)		13 1/2 (343)							

\*Fabricated subbase "HG" is 3/8" when used to establish foundation bolt length.

Dimensions shown are not for construction unless certified. Dimensions are shown in inches and (approximate equivalent millimeters). All flanges same as 150 lbs. American Standard Cast Steel.

Field shimming by customer may be required to meet maximum ANSI B73.1 HD dimensions. Subbase dimensions are for cast iron or steel, fabricated or non-metallic designs.



## General Installation Recommendations

### Choosing Pump Location

Locate the pump as close to the liquid source as practical so the suction pipe is short and direct with a minimum of elbows, fittings and valves.

Place the pump in a location so the unit is accessible for inspection during operation as well as for maintenance operations involving removal and disassembly.

### Foundation

The foundation should be strong enough to absorb any vibration and to form a permanent support for the subbase. This is important in maintaining the alignment of the direct connected unit. A concrete foundation on a solid base is satisfactory. Foundation bolts of the proper size should be embedded in the concrete located by the outline drawing.

### Alignment

The pump and motor are aligned at the factory before shipment. Realignment may be necessary after the complete unit has been leveled on the foundation and after the foundation bolts have been tightened. Explicit directions for checking and aligning the pump components may be found in the Hydraulic Institute Standards.

### Piping

Both suction and discharge pipes should be supported independently near the pump so when the flange bolts are tightened no strain will be transmitted to the pipe casing.

A check valve and a gate valve are often installed in the discharge line. The check valve is used to prevent fluid from flowing back through the pump while it is shut down. The gate valve blocks the discharge line during maintenance.

Care should be taken in sizing and locating suction piping to prevent cavitation.

### Ordering Information

Wilfley pumps are engineered to operate in compliance with exact specifications. Careful evaluation of pumping conditions is needed to provide accurate pump recommendations and quotations.

This list will help establish specific pumping conditions.

- Solution
- Temperature
- Static Head
- Discharge Pipe Size
- Length, Discharge Pipe
- Discharge Pipe Fittings
- Equivalent Length Discharge Pipe
- Total Head
- Maximum Suction Pressure
- Minimum Suction Pressure
- Capacity
- Specific Gravity
- % Solids by Weight
- Mesh Analysis
- Viscosity
- NPSH Available



### Illinois Location:

(847) 841-7867

860 Church Rd Elgin, IL 60123

### Minnesota Location:

(651) 758-7867

330 Mill Bay South Suite 1511 Afton, MN 55001

PumpSupplyInc.com