

# 6" Self-Priming Engine Driven Trash Pumps

- **Cast Aluminum Casing, Seal Plate and Bell Housing**
- **Cast Iron Adapter, Volute and Suction and Discharge Manifold**
- **Trash Type Stainless Steel Impeller**
- **Silicon Carbide Mechanical Seal and Buna-N O-Rings and Check Valve**
- **6" NPT Port Size**
- **Self-Priming to 20 Feet**
- **Engine Options: Honda V-Twin or Kohler Diesel Engine**
- **Solids Handling and Dirty Water Design**
- **Maximum Solids Handling 3"**
- **Patented Unique Slide Mechanism Permits Complete Service of Pump Without Removing Hoses or Removing Pump Components from Trailer**
- **Seal Wash Feature for Extended Seal Life**



Diesel Driven Trash Pump

The AMT 6" Engine Driven Trash Pump is designed for applications requiring high volume flow and solid/debris handling capabilities. Pumps are designed to handle liquids with solids content or dissolved solids and debris. Pump is constructed of heavy duty sand cast aluminum with cast iron and stainless steel internal parts for wear resistance and durability. **Patented built-in slide mechanism** features nylon and powder coated steel components that permit servicing, repairing and cleaning entire pump without removing hoses or pump components from trailer. Digital tachometer/hourmeter installed.

Requires 12 Volt Battery: BCI Group 24, Minimum of 500 CCA (Cold Crank Amps) Battery Box Cables Setup for Automotive Post Type Connection.

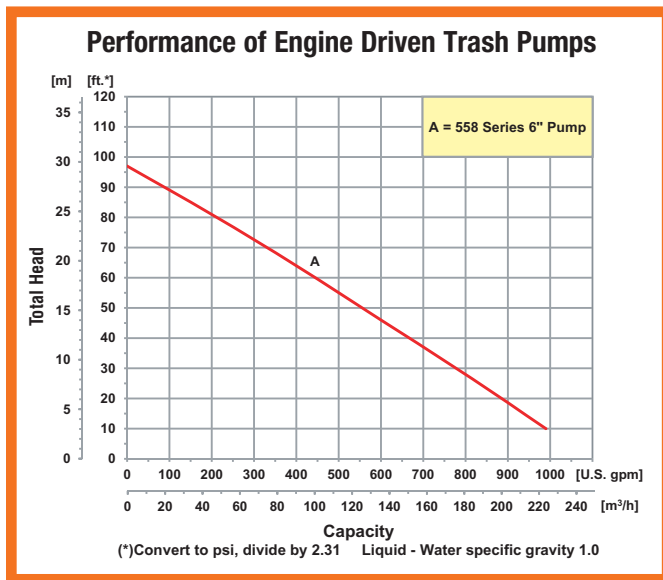



# Engine Driven Self-Priming Trash Pumps

## 6" Trash Pumps



Model	Driver	Base	Engine Type	Run Type (Hours)	Tank Size (Gal./Ltr.)	Ship Wt. (Lbs.)
5585-H6	Honda V-Twin OHV +++▲	Trailer	2 Cyl. Air Cooled	9	20 / 75.7	1,000
5586-H6	Honda V-Twin OHV +++▲	Skid	2 Cyl. Air Cooled	9	20 / 75.7	725
5587-D6	Kohler KDW1003 Diesel +++▲	Trailer	3 Cyl. Liquid Cooled	12	20 / 75.7	1,250
5588-D6	Kohler KDW1003 Diesel +++▲	Skid	3 Cyl. Liquid Cooled	12	20 / 75.7	975

**Construction: Cast Aluminum with Cast Iron and Stainless Steel Components**  
 +++ Electric Start, Requires 12V DC, BCI Group 24, MIN 500 CCA Battery (Battery Not Included)  
 ▲ Oil Alert Included

**Maximum Solids Handling Capacity: 3" Diameter**

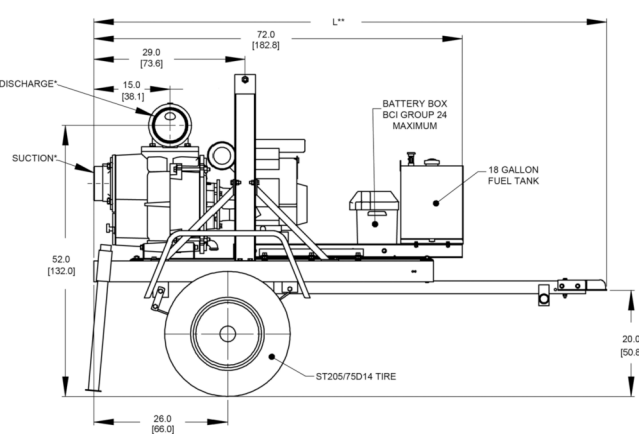
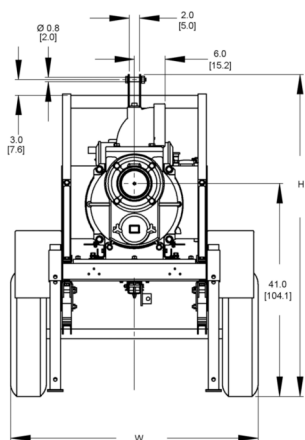

**Trailer Model**

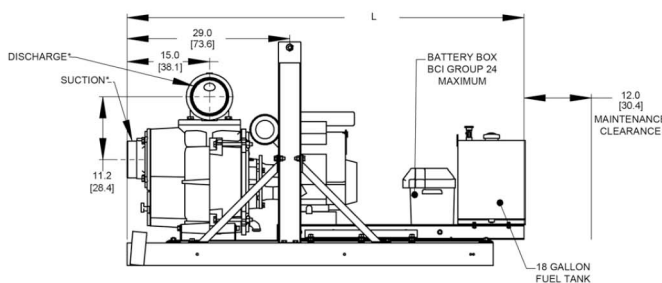
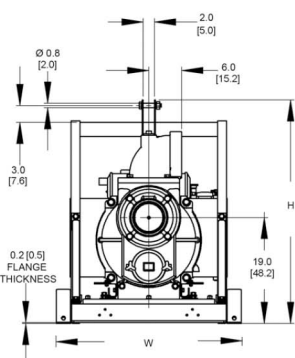

**Skid Model**

Model	HP Class ♦	SUC*	DIS*	L**	W	H
5585-H6	23	6	6	99.0 [251.4]	48.0 [121.9]	62.0 [157.4]
5586-H6	23	6	6	71.0 [180.3]	33.0 [83.8]	40.0 [101.6]
5587-D6	23	6	6	99.0 [251.4]	48.0 [121.9]	62.0 [157.4]
5588-D6	23	6	6	71.0 [180.3]	33.0 [83.8]	40.0 [101.6]

♦ HP Class represents market category and is not intended to define actual horsepower.

(\*) Standard NPT pipe thread.

(\*\*) This dimension may vary due to engine manufacturer's specifications.

NOTE: Dimensions are in inches (centimeters) and have a tolerance of ± 1/8".

## Standard Features

- Cast Aluminum with Cast Iron and Stainless Steel Components for Long Lasting Durability
- Silicon Carbide/Viton® Mechanical Seal and Buna-N O-rings and Check Valve
- Built-in Check Valve for Fast Priming to 20 Feet
- Maximum Solids Handling 3"
- 6" NPT Port Size
- Delivers up to 1,000 GPM
- Digital Tachometer/ Hourmeter Installed
- Maximum Temperature 180° F
- 12 Volt DC Electric Start
- Available in Trailer or Skid Mounted
- D.O.T. Approved Trailer—Refer to Your State and Local Codes for Registration
- Easy Cleanout and Service Features with the Unique AMT Patented Slide Mechanism
- Steel Suction Strainer and Nipple Included
- Seal Wash Feature for Extended Seal Life



**Manufacturer of AMT & IPT Pumps**

400 Spring Street • Royersford, PA 19468 USA

[www.amtpump.com](http://www.amtpump.com) • 888-amt-pump (268-7867)

The Gorman-Rupp Company reserves the right to discontinue any model or change specifications at any time without incurring any obligation.  
 ©2012 American Machine and Tool Company. All rights reserved.

