

Please read and save this Repair Parts Manual. Read this manual and the General Operating Instructions carefully before attempting to assemble, install, operate or maintain the product described. Protect yourself and others by observing all safety information. The Safety Instructions are contained in the General Operating Instructions. Failure to comply with the safety instructions accompanying this product could result in personal injury and/or property damage! Retain instructions for future reference. AMT reserves the right to discontinue any model or change specifications at any time without incurring any obligation.

©2019 AMT Pump Company, A Subsidiary of The Gorman-Rupp Company, All Rights Reserved.

Periodic maintenance and inspection is required on all pumps to ensure proper operation. Unit must be clear of debris and sediment. Inspect for leaks and loose bolts. Failure to do so voids warranty.

# 1 1/2-Inch Sprinkler/Booster Pumps

Refer to pump manual 1808-634-00 for General Operating and Safety Instructions.



## DESCRIPTION

These 2-stage sprinkler/booster pumps are equipped with high performance 300 series stainless steel closed impellers, a Buna-N mechanical seal to prevent leakage and a continuous duty motor. Pumps are designed for higher pressure applications such as: lawn sprinkling, spraying irrigation; also draining and general dewatering applications. Handles liquids from 40° F to 180° F (4° to 82° C). For use with nonflammable, non-abrasive liquids compatible with pump component materials.

## MAINTENANCE

### ▲ WARNING

**Make certain that unit is disconnected from power source before attempting to service or remove any components!**

### MECHANICAL SEAL REPLACEMENT

Refer to Figures 1, 2 and 3

**IMPORTANT:** Always replace both seal seat (Ref. No. 5) and seal head (Ref. No. 6) to ensure proper mating of components!

1. Unthread bolts (Ref. No. 20) and remove pump casing (Ref. No. 19) and o-ring (Ref. No. 17) from adapter (Ref. No. 2).
2. Unthread socket cap screws (Ref. No. 15) and remove suction inlet (Ref. No. 13) and o-ring (Ref. No. 12) from diffuser (Ref. No. 8).
3. Unthread hex nut (Ref. No. 11) from shaft.

**NOTE:** Some motors use an open end 7/16" wrench across flats on rear of motor shaft (remove bearing cap for access) to prevent shaft from turning. Other motor shafts have a screwdriver slot instead of flats.

4. Unscrew first stage impeller (Ref. No. 7) from shaft (impeller unscrews CCW looking at shaft).

**NOTE:** A strap wrench is recommended to loosen both impellers. Attempts to loosen impellers with other tools may cause permanent damage to impellers. Due to close running fits between parts, damaged impellers should be replaced before reassembly of pump.

5. Unthread cap screws (Ref. No. 15) and remove diffuser and diffuser/crossover (Ref. No. 9) from adapter as a unit.
6. Remove shaft sleeve (Ref. No. 10) from shaft and unscrew second stage impeller (Ref. No. 7).
7. Remove seal head from shaft.
8. Unscrew four bolts (2-Ref. No. 21 and 2-Ref. No. 4) and remove foot (Ref. No. 22) and adapter from motor mounting face.
9. Push seal seat from adapter recess with a screwdriver.
10. Clean adapter recess before inserting a new seal seat.
11. Carefully wipe polished surface of new seal seat with a clean cloth.
12. Wet the rubber portion of new seal seat with a light coating of soapy water.
13. Press new seal seat squarely into cavity in adapter. If seal seat does not press squarely into cavity, it can be adjusted in place by pushing on it with a piece of pipe. Always use a piece of cardboard between pipe and seal

seat to avoid scratching seal seat (This is a lapped surface and must be handled very carefully).

14. After seal seat is in place, be sure that it is clean and has not been marred.
15. Using a clean cloth, wipe shaft and make certain that it is perfectly clean.

**NOTE:** The stub shaft position is factory set to provide proper seal and impeller location. Do not loosen the collar (Ref. No. 8) or remove stub shaft during mechanical seal replacement or entire rotor will need resetting during reassembly. (See ROTOR ADJUSTMENT on next page.)

16. Carefully guide seal seat over shaft and secure adapter and foot to motor mounting face.
17. Apply a light coating of soapy water to inside rubber portion of seal head and slide onto shaft (with polished sealing face first) so that rubber portion is just over the shoulder at end of threads on shaft.

### ▲ WARNING

**Do not touch or wipe seal face of seal head.**

18. Screw second stage impeller back in place and tighten using a strap wrench on impeller shroud opening until impeller is against shaft shoulder.

**NOTE:** A strap wrench is required to tighten both impellers. Use of any other kind of tool could permanently damage impeller and cause damage to pump due to close running fits between impellers, diffuser and suction inlet.

19. Slide shaft sleeve onto shaft.
20. Apply small amount of grease or Vaseline on outside shroud of impeller opening and shaft sleeve. Remount diffuser and diffuser/crossover. Before tightening cap screws, rotate shaft and be sure impeller and shaft sleeve are not rubbing on diffuser or diffuser/crossover.
21. Screw first stage impeller into place and tighten with a strap wrench.
22. Install hex nut to end of shaft.
23. Remount suction inlet and o-ring, then rotate shaft to be sure impeller is not rubbing on suction inlet before tightening cap screws.
24. Apply small amount of Vaseline to outside of diffuser at o-ring location and on flange of suction inlet. Install o-ring and gasket (Ref. No. 16).

**IMPORTANT:** Always inspect o-ring and gaskets. When cut, cracked or worn, replace them. Wet o-rings with Vaseline when reassembling pump for ease of assembly and to prevent pinching.

25. Remount pump casing.
26. A short "run-in" period may be necessary to provide completely leak-free seal operation.

# 1 1/2-Inch Sprinkler/Booster Pumps

## ROTOR ADJUSTMENT

When installing a replacement impeller (Ref. No. 7), motor (Ref. No. 1), or stub shaft (Ref. No. 25), it will be necessary to adjust rotor setting to ensure proper running clearance between the impellers and the diffusers. Proceed as follows:

**NOTE:** Proper running clearance on this pump will determine both the hydraulic efficiency and life of mechanical seal. Follow this procedure carefully to maximize both.

1. Rotor is set by loosening collar (Ref. No. 24) and sliding stub shaft (Ref. No. 25) onto or off of motor (Ref. No. 1) shaft. This procedure must be done with pump partially assembled (See MECHANICAL SEAL REPLACEMENT steps 1 through 18).
2. Stub shaft is to be set so face of shaft is between 0.114" from adapter face (See Figure 2).
3. Tighten fasteners on stub shaft collar and recheck running clearance before proceeding with reassembly of pump.
4. Continue with reassembling as in mechanical seal replacement with steps 19 through 26.
5. Always be sure during assembly to rotate impellers and check for parts rubbing before tightening fasteners.

**Illinois Location:**

(847) 841-7867

860 Church Rd Elgin, IL 60120

**Minnesota Location:**

(651) 758-7867

330 Mill Bay South Suite  
Afton, MN 55001

PumpSupplyInc.com



# 1 1/2-Inch Sprinkler/Booster Pumps

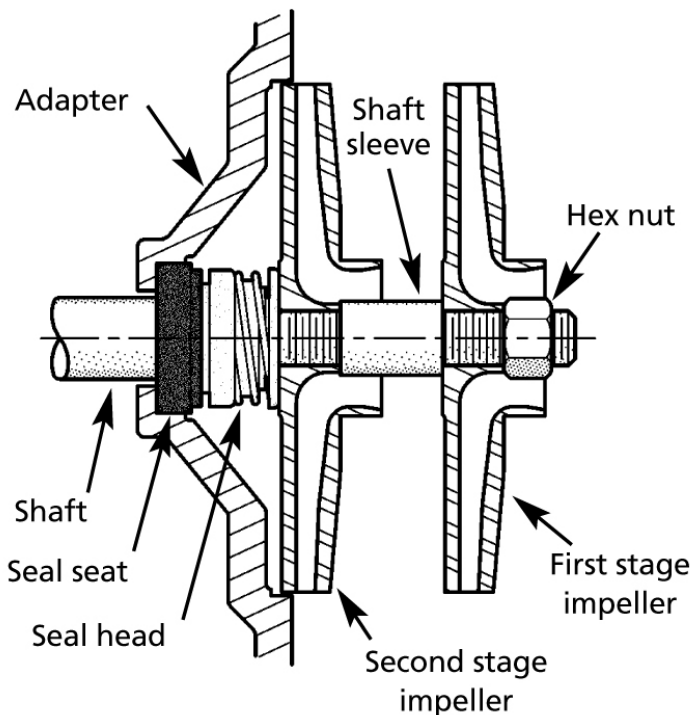

Figure 1 - Mechanical Seal Replacement - 4782-95

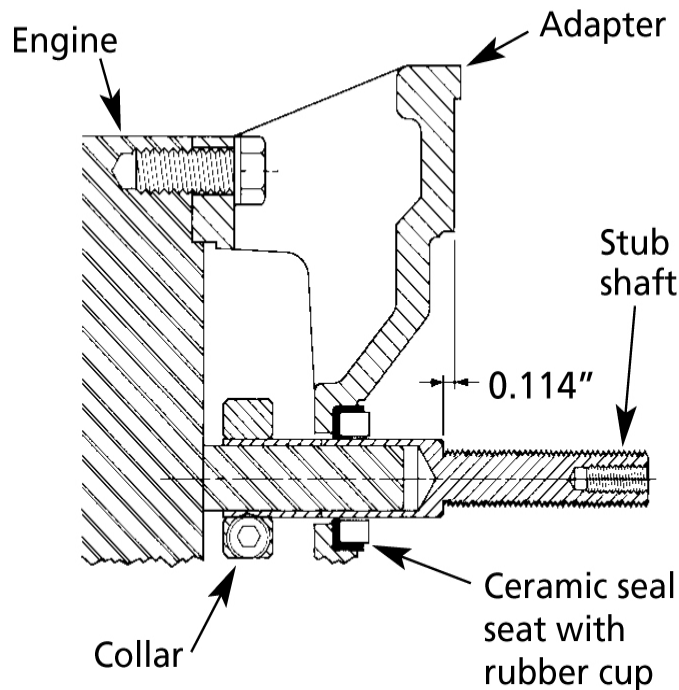



Figure 2 - Mechanical Seal Replacement - 4786-95

**Illinois Location:**  
 (847) 841-7867  
 860 Church Rd Elgin, IL 60120

**Minnesota Location:**  
 (651) 758-7867  
 330 Mill Bay South Suite :  
 Afton, MN 55001

PumpSupplyInc.com





**PUMP SUPPLY**  
INCORPORATED

# 1 1/2-Inch Sprinkler/Booster Pumps

**For Repair Parts contact dealer where pump was purchased.**

Please provide following information:

-Model Number

-Serial Number (if any)

Part description and number as shown in parts list

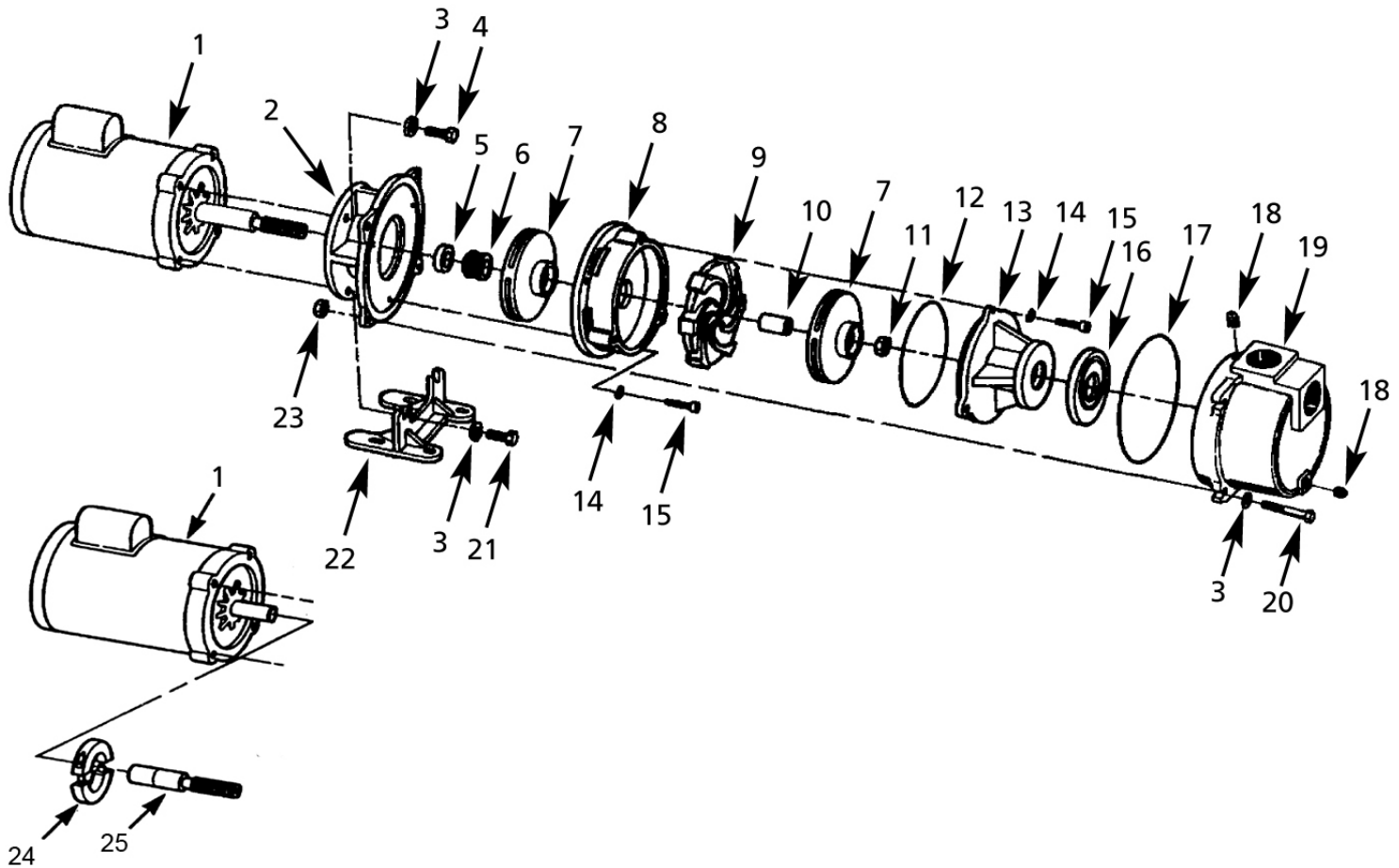

Figure 3 - Repair Parts Illustrations

**Illinois Location:**

(847) 841-7867  
860 Church Rd Elgin, IL 61

**Minnesota Location:**

(651) 758-7867  
330 Mill Bay South Suite  
Afton, MN 55001

PumpSupplyInc.com



## Repair Parts List

Ref No.	Description	Part Number for Models		Qty
		4782-95	4786-95	
1	Motor Kit w/ Extended Threaded Shaft (includes Ref. Nos. 1, 24 and 25)	1626-093-00	1627-094-90	1
2	Adapter Kit (includes Ref. Nos. 2, 3 and 4)	4780-031-95	4780-031-95	1
3	3/8" Washer	Incl. w/ Ref 2	Incl. w/ Ref 2	8
4	3/8" Bolt	Incl. w/ Ref 2	Incl. w/ Ref 2	2
5 & 6	Seal Assembly – Buna-N	1640-162-90	1640-162-90	1
7	Impeller Kit (2 per kit)	4785-011-98	4785-011-98	1
8	Diffuser Kit (includes Ref. Nos. 8, 14 and 15)	4780-150-95	4780-150-95	1
9	Diffuser/Crossover	4780-155-95	4780-155-95	1
10	Shaft Sleeve	4780-141-00	4780-141-00	1
11	Shaft Hex Nut	4780-144-00	4780-144-00	1
12	Gasket/O-Ring Kit – Buna-N (includes Ref. Nos. 12, 16 and 17)	4780-300-94	4780-300-94	1
13	Suction Inlet Kit (includes Ref. Nos. 14 and 15)	4780-220-95	4780-220-95	1
14	#10 SS Lock Washer	Incl. w/ Ref 8 & 13	Incl. w/ Ref 8 & 13	6
15	#10 Screw	Incl. w/ Ref 8 & 13	Incl. w/ Ref 8 & 13	6
16	Suction Gasket – Buna-N	Incl. w/ Ref 12	Incl. w/ Ref 12	1
17	O-Ring – Buna-N	Incl. w/ Ref 12	Incl. w/ Ref 12	1
18	1/2" NPT Pipe Plug	Incl. w/ Ref 19	Incl. w/ Ref 19	2
19	Casing Kit (includes Ref. Nos. 18, 19 and 20)	4780-002-95	4780-002-95	1
20	3/8" Bolt	Incl. w/ Ref 19	Incl. w/ Ref 19	4
21	3/8" Bolt	Incl. w/ Ref 2	Incl. w/ Ref 2	2
22	Mounting Base (foot)	1506-000-00	1506-000-00	1
23	3/8" Flange Nut	Incl. w/ Ref 2	Incl. w/ Ref 2	4
24	Clamp	Incl. w/ Ref 1	Incl. w/ Ref 1	1
25	Stub Shaft	Incl. w/ Ref 1	Incl. w/ Ref 1	1
	Drive Pin (not shown)	Incl. w/ Ref 8 & 13	Incl. w/ Ref 8 & 13	1

(\*) Standard hardware item, available locally.

**Illinois Location:**  
(847) 841-7867  
860 Church Rd Elgin, IL 60120

**Minnesota Location:**  
(651) 758-7867  
330 Mill Bay South Suite 100  
Afton, MN 55001

PumpSupplyInc.com



**PUMP SUPPLY**  
INCORPORATED







**AMT Pump Company**  
(herein "AMT")  
400 Spring Street  
Royersford, PA 19468  
Phone: (610) 948-3800  
Fax: (610) 948-5300  
www.amtpump.com



## General Information

**SALES POLICY:** AMT products are sold through our established Distributors. We do not sell direct to the consumer or organization not entitled to trade recognition. Therefore, possession of our catalogs and/or price list(s) does not infer an offer to sell.

**MINIMUM ORDER:** We appreciate your order, however, all orders are subject to a minimum \$35.00 net invoice charge (excluding freight). This applies to all pump and parts purchase orders.

**PRICES:** Prices are subject to change without notice. All orders accepted are subject to prices in effect at time of shipment.

**PAYMENT TERMS:** Terms, upon establishment of credit, are Net 30 days. Past due accounts may be subject to a service charge of 1.5% per month. Domestic or assignable letter of credit is required for all export trade.

**PAST DUE ACCOUNTS:** AMT reserves the right to withhold open account shipments on any past due account. Invoices are considered past due after thirty (30) days. In the interest of sound business, all orders are subject to approval of the Credit Department.

**SHIPPING INSTRUCTIONS:** All shipments will be made F.O.B. the factory. Where instructions for shipment do not appear on the order, the shipment will be made according to our best judgment. Full risk of loss (including transportation delays and losses) shall pass to the customer upon delivery of the products to the carrier at the F.O.B. point. When loss or delay occurs, primary responsibility for tracing rests with the customer. When there is LOSS or APPARENT VISIBLE DAMAGE to a shipment, when tendered for delivery, *DO NOT* give the carrier a clear receipt. Note such damage on the carrier's delivery receipt and *HAVE THE DRIVER SIGN THE RECEIPT.*

**PRODUCT REVISIONS:** AMT reserves the right to discontinue, change or improve its products or any portions thereof without being obligated to provide such a change or improvement for units sold and/or shipped prior to such a change or improvement.

## 12 Month Limited Warranty

### EXTENT AND DURATION OF LIMITED WARRANTY

**Coverage:** AMT Pump Company (herein "AMT") or IPT Pumps by Gorman-Rupp (herein "IPT") or Gorman-Rupp Industries Division of the The Gorman-Rupp Company, Patterson, or the Gorman-Rupp Company (herein referred to as "G-R Unit") each individually warrants that its products and parts shall be free from defects in material and workmanship for twelve (12) months from the date of purchase by the original end user when installation is made and maintenance is performed in accordance with G-R Unit's recommendations. Wear and tear resulting from use and items normally consumed in use are not covered.

### EXCEPTIONS

( A ) This Limited Warranty shall not apply to mechanical seals in AMT or IPT pumps and the following products and parts: engines, motors, trade accessories and all other products, components, parts and materials not manufactured by the G-R Units. These items may, however, be covered by the warranties of their respective manufacturers. ( B ) This warranty does not extend to or apply to any unit which has been repaired or altered at any place other than by a G-R Unit, or by persons not expressly approved by a G-R Unit to make repairs or alterations, nor to any unit the serial number, model number or identification of which has been removed, defaced or altered. ( C ) This warranty does not extend to any product manufactured by a G-R Unit, which has been subjected to mis-use, neglect, accident, improper installation, or use in violation of instructions furnished by a G-R Unit. ( D ) Pump Kits: This warranty does not extend to any product sold by a G-R Unit unassembled as a Pump Kit. Pump Kits are warranted against defects in material and workmanship for 60 days from the date of shipment from a G-R Unit. Any Pump Kit parts deemed defective by a G-R Unit will be replaced free of charge within 60 days of shipment. Pump Kits are not returnable for credit.

### LIMITATIONS

**THE G-R UNITS' SOLE AND EXCLUSIVE WARRANTY WITH RESPECT TO THEIR PRODUCTS AND PARTS IS THIS LIMITED WARRANTY. THIS LIMITED WARRANTY IS IN LIEU OF ALL OTHER EXPRESS AND/OR IMPLIED WARRANTIES, INCLUDING IMPLIED WARRANTIES OF MERCHANTABILITY AND FITNESS FOR PARTICULAR PURPOSE.**

### EXCLUSIVE REMEDY AND DAMAGES

The sole and exclusive remedy for breach of this Warranty by a G-R Unit and the entire extent of its liability for such breach or for damages arising from the use of the products and parts covered under this Limited Warranty, shall be as follows:

**LEAD TIME:** Products designated "Quick Ship Product", also referred to as "QSP" will normally be shipped within 24 hours of receipt of a non-cancellable purchase order. Only limited quantities of "QSP" pumps are available.

**STANDARD LEAD TIME:** Lead time is two weeks for all non "QSP" product. AMT reserves the right to revise lead times as required due to availability of materials and all other causes beyond our control.

**VIP SHIPMENT:** Select AMT and IPT branded pumps are available for next day shipment for non-QSP (Quick Ship Products) items and subjected to a specific model surcharge per unit noted in the respective price book. Requires calling for availability, confirmation and a non-cancellable purchase order or credit card payment prior to shipment. The expedited shipping charges are an additional cost added separately from the VIP charges per item. AMT reserves the right to revise lead times as required due to availability of materials and all other causes beyond our control. QSP quantities are limited as determined by AMT.

ALL purchase orders must be submitted via hard copy sent to AMT customer service department by fax, EDI or e-mail.

**RETURN GOODS POLICY:** Goods shall not be returned without a return goods authorization number (RGA) issued by AMT customer service. The RGA number must be listed on the packing list. Only current model and part numbers with a valid date code may be returned (within one year from date of purchase). **A 20% restocking and packaging charge will apply to all returns. All shipping charges must be pre-paid. No exceptions.**

**ORDER CHANGES BY CUSTOMER:** Orders in process may not be changed except with written consent and may be subject to special charges.

1. **Repair or Replacement:** If inspection shows that any G-R Unit product or part covered under this Limited Warranty is defective in materials or workmanship, the G-R Unit shall repair or replace the defective or non-conforming product or part without charge, whichever the G-R Unit chooses. You must have properly maintained and used the product or part claimed to be defective in accordance with the maintenance schedule or manual, which comes with the product. No allowance will be made for labor, installation, removal, transportation or other charges incurred by you in connection with such repair or replacement.
2. To obtain the above remedy:
  - A. Immediately notify the G-R Unit upon discovery of the claimed defect in materials or workmanship and provide the serial number or date code of the product and/or part(s) or provide the G-R Unit with the invoice or bill of sale referencing the product by no later than the expiration date of the warranty period.
  - B. The G-R Unit will advise whether inspection will be necessary and how whether repair or replacement will be made. If inspection by the G-R Unit is necessary, the pump or defective part must be sent freight pre-paid to the G-R Unit. Return shipment will be F.O.B. the G-R Unit's plant.
  - C. **Return Goods Authorization Requirement:** No product will be accepted for return or replacement without the prior written authorization of the G-R Unit. Upon such authorization, and in accordance with instructions from the G-R Unit, the product will be returned to the G-R Unit, shipping charges prepaid by the Buyer.
3. **Damages:** The G-R Unit's liability for damages for breach of this Limited Warranty shall not exceed the amount of the purchase price of the product or part(s) in respect to which Such damages are claimed. **IN NO EVENT SHALL THE G-R UNITS BE LIABLE FOR INCIDENTAL, CONSEQUENTIAL OR SPECIAL DAMAGES FOR BREACH OF THIS LIMITED WARRANTY.**

Some states do not allow the exclusion or limitation of incidental or consequential damages, so the above limitation or exclusion may not apply to you. This Limited Warranty gives you specific legal rights, and you may also have other rights, which vary from state to state.



**A Gorman-Rupp Company**

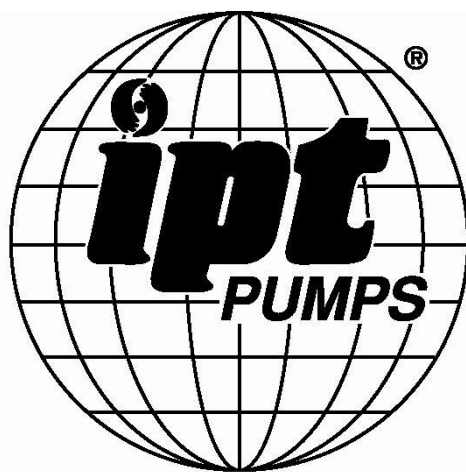

**BY  
GORMAN-RUPP®**

**Illinois Location:**

(847) 841-7867  
860 Church Rd Elgin, IL 60120

**Minnesota Location:**

(651) 758-7867  
330 Mill Bay South Suite  
Afton, MN 55001

[PumpSupplyInc.com](http://PumpSupplyInc.com)

