

# Stainless Steel Centrifugal Pump



**PUMP SUPPLY**  
INCORPORATED

**Model 3U**



## Operating, Installation, and Maintenance

**Illinois Location:**

(847) 841-7867

860 Church Rd Elgin, IL 60120

**Minnesota Location:**

(651) 758-7867

330 Mill Bay South Suite  
Afton, MN 55001

PumpSupplyInc.com



**EBARA**

EBARA Pumps Americas Corporation

**EBARA Stainless Steel Centrifugal Pumps****Model 3U****Operating, Installation, and Maintenance****Contents**

<b>Section</b>	<b>Page</b>
Safety Specifications and Installation	2
3U Selection Chart	4
3U Specifications	5
3U Type 1 Sectional View and Parts List	6
3U Type 2 Sectional View and Parts List	7
3U 65 Type 3 Sectional View and Parts List	8
Installation Instructions	9
Maintenance and Service	10
3U Assembly – 3HP - 15HP	11
3U Assembly – 20HP - 30HP	13
Troubleshooting Checklist and Maintenance Information	14

**Note:** Only products bearing the NSF Mark on the product, product packaging, and/or documentation shipped with the product are Certified.

**WARNING**

**IMPORTANT SAFETY INSTRUCTIONS**  
**Rules for Safe Installation and Operation**

1. Read these rules and instructions carefully. Failure to follow them could cause serious bodily injury and/or property damage.
2. Check your local codes before installing. You must comply with their rules
3. For maximum safety, this product should be connected to a grounded circuit equipped with a ground fault interrupter device.
4. Before installing this product, have the electrical circuit checked by an electrician to make sure it is properly grounded.
5. Before installing or servicing your pump, BE CERTAIN pump power source is disconnected.
6. Make sure the line voltage and frequency of the electrical current supply agrees with the motor wiring. If motor is dual voltage type, BE SURE it is wired correctly for your power supply.
7. Complete pump and piping system MUST be protected against below freezing temperature. Failure to do so could cause severe damage and voids the Warranty.
8. Avoid system pressures that may exceed one and a half times the operating point selected from the pump performance curve.
9. Do not run your pump dry. If it is, there will be damage to the pump seal.

**Installation****PACKAGE CONTENTS**

1. Be sure all parts have been furnished and that nothing has been damaged in shipment.
2. The catalog lists all parts included with package. A packing list packed with pump, also lists contents.
3. OPEN PACKAGES AND MAKE THIS CHECK BEFORE GOING ON JOB.

**PIPING** – Pipes must line up and not be forced into position by unions. Piping should be independently supported near the pump so that no strain will be placed on the pump casing. Where any noise is objectionable, pump should be insulated from the piping with rubber connections. Always keep pipe size as large as possible and use a minimum of fittings to reduce friction losses.

**SUCTION PIPING** – Suction pipe should be direct and as short as possible. It should be at least one size larger than suction inlet tapping and should have a minimum of elbows and fittings (5 to 6 pipe diameters of straight pipe before inlet is recommended). The piping should be laid out so that it slopes upward to pump without dips or high points so that air pockets are eliminated. The highest point in the suction piping should be the pump inlet except where liquid flows to the pump inlet under pressure.

The suction pipe must be tight and free of air leaks or pump will not operate properly.



**PUMP SUPPLY**  
 INCORPORATED

**EBARA Stainless Steel Centrifugal Pumps****Model 3U****Operating, Installation, and Maintenance****Rules for Safe Installation and Operation** (continued)

**DISCHARGE PIPING** – Discharge piping should never be smaller than pump outlet and should preferably be one size larger. A gate valve should always be installed in discharge line for throttling if capacity is not correct. To protect the pump from water hammer and to prevent backflow, a check valve should be installed in the discharge line between the pump and gate valve.

**ELECTRICAL CONNECTIONS** – Be sure motor wiring is connected for voltage being used. Unit should be connected to a separate circuit. A fused disconnect switch or circuit breaker must be used in this circuit. Wire of sufficient size should be used to keep voltage drop to a maximum of 5%.

Single phase motors have built-in overload protection. Flexible metallic conduit should be used to protect the motor leads.

**PRIMING** – The pump must be primed before starting. The pump casing and suction piping must be filled with water before starting motor. When water is poured into pump to prime, remove all air before starting motor.

**STARTING** – When the pump is up to operating speed, open the discharge valve to obtain desired capacity or pressure.

**WARNING! DO NOT ALLOW THE PUMP TO RUN WITH THE DISCHARGE VALVE TIGHTLY CLOSED. IF THE PUMP RUNS FOR AN EXTENDED PERIOD OF TIME WITHOUT LIQUID BEING DISCHARGED, THE LIQUID IN THE PUMP CASE CAN GET EXTREMELY HOT CAUSING SEVERE DAMAGE TO THE PUMP AND POSSIBLY CAUSE INJURY TO PEOPLE.**

**ROTATION** – All single phase motors are single rotation and leave factory with proper rotation. Three phase motors should be checked to ensure proper rotation

**FREEZING** – Care should be taken to prevent the pump from freezing during cold weather. It may be necessary, when there is any possibility of this, to drain the pump casing when not in operation. Drain by removing the pipe plug in the bottom of the casing.

**MECHANICAL SEAL** – This seal is recommended for LIQUIDS free from abrasives.

**LOCATION OF UNIT** – The pump should be installed as near to the liquid source as is practical so that the static suction head (vertical distance from the center line of the pump to water level) is maximized, and so that a short, direct suction pipe may be used. The capacity of a centrifugal pump is reduced when the unit is operated under a high suction lift. The piping should be as free from turns and bends as possible, as elbows and fittings greatly increase friction loss. Place the unit so that it is readily accessible for service and maintenance and on a solid foundation, which provides a rigid and vibration-free support. Protect the pump against flooding and excess moisture.

<p><b>Illinois Location:</b> (847) 841-7867 860 Church Rd Elgin, IL 60120</p> <p><b>Minnesota Location:</b> (651) 758-7867 330 Mill Bay South Suite Afton, MN 55001</p> <p>PumpSupplyInc.com</p>	
--	--

**EBARA Stainless Steel Centrifugal Pumps**

**Model 3U**

**Operating, Installation, and Maintenance**

	Standard	Optional
<b>Size</b> Suction (150 lb. ANSI R.F. equivalent)  Discharge (150 lb. ANSI R.F. equivalent)	3U32 – 2” ANSI Equivalent 3U40 – 2½” ANSI Equivalent 3U50 – 2½” ANSI Equivalent 3U65 – 3” ANSI Equivalent  3U32 – 1¼” ANSI Equivalent 3U40 – 1½” ANSI Equivalent 3U50 – 2” ANSI Equivalent 3U65 – 2½” ANSI Equivalent	Companion Flange kit 150 LB. ANSI, Female NPT
<b>Range of HP</b>	3U – 1 HP to 30 HP	
<b>Range of Performance</b> Capacity Head	5 to 633 GPM at 3450 RPM 9 to 282 Feet at 3450 RPM	
<b>Liquid Handled</b> Type of liquid Temperature  Max. working pressure	Clean water 14° F to 212°F (-10°C to 100°C)  145 PSI (10 Bar)	Min. -4°F (-20°C) with Carbon/Ceramic/EPDM seal Max. 250°F (121°C) with Carbon/ Ni-Resist/Viton seal
<b>Materials</b> Casing Impeller (closed type) Shaft Sleeve/Coupling Bracket	3U 304L Stainless Steel 304L Stainless Steel 304L Stainless Steel Cast Iron	3U65 304L Stainless Steel 304L Stainless Steel, 316SS 304L Stainless Steel Cast Iron
<b>Shaft Seal</b> Seal Material	Mechanical Seal – Type 21 Carbon/Ceramic/Viton	Carbon/Ceramic/Buna Carbon/Ni-Resist/Viton Carbon/Ceramic/EPDM Si-Carbide/Carbon/Viton Si-Carbide/Si-Carbide/Viton
<b>Direction of Rotation</b>		
Motor Type Speed Bearing Single Phase  Three Phase  Motor Protection	NEMA JM, TC, TSC Frame 60 Hz, 3450 RPM (2 poles) / 1750 RPM (4 poles) Ball Bearing TEFC – 3 HP (230V) ODP – 3 HP to 10 HP (230 V)  TEFC – 3 HP to 30 HP ODP – 3 HP to 30 HP 230/460V  Overload protection must be provided	Explosion proof – consult factory for availability Washdown duty – consult factory for availability
<b>Standard Accessories</b>	Suction and Discharge Flange Gasket Motor Support	

**Illinois Location:**  
 (847) 841-7867  
 860 Church Rd Elgin, IL 60120

**Minnesota Location:**  
 (651) 758-7867  
 330 Mill Bay South Suite 100  
 Afton, MN 55001  
 PumpSupplyInc.com



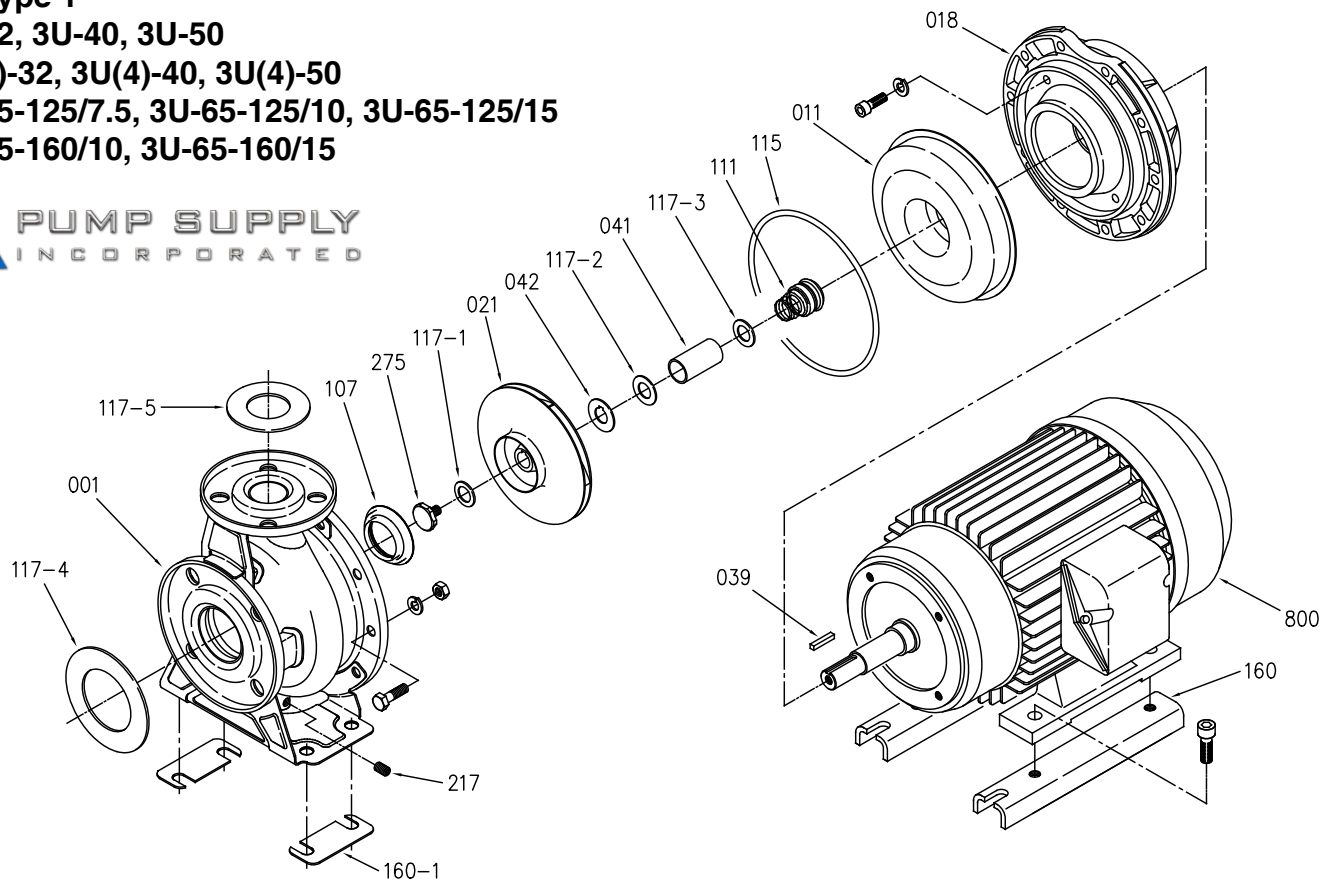

**EBARA Stainless Steel Centrifugal Pumps****Model 3U****Operating, Installation, and Maintenance****3U Type 1****3U-32, 3U-40, 3U-50****3U(4)-32, 3U(4)-40, 3U(4)-50****3U-65-125/7.5, 3U-65-125/10, 3U-65-125/15****3U-65-160/10, 3U-65-160/15**

Part No.	Part Name	Materials	No. for 1 Unit
001	Casing	304L Stainless	1
011	Casing Cover	304L Stainless	1
018	Bracket	Cast Iron	1
021	Impeller	304L Stainless	1
039	Key	304L Stainless	1
041	Shaft Sleeve	304L Stainless	1
042	Impeller Spacer	304L Stainless	1
107	Liner Ring	304L Stainless + PTFE	1
111	Mechanical Seal	varies by model	1
115	O-Ring	Viton/EPDM	1
117-1	Gasket	Nylon	1
117-2	Gasket	Nylon	1
117-3	Gasket	Nylon	1
117-4	Suction Flange Gasket	EPDM	2
117-5	Discharge Flange Gasket	NBR/EPDM	2
160	Motor Support	Steel	2
160-1	Casing Support	Steel	2
217	Drain Plug	304L Stainless	1
275	Impeller Bolt	304L Stainless	1
800	Motor	-	1

Pump will use either motor supports or casing supports, depending on model.

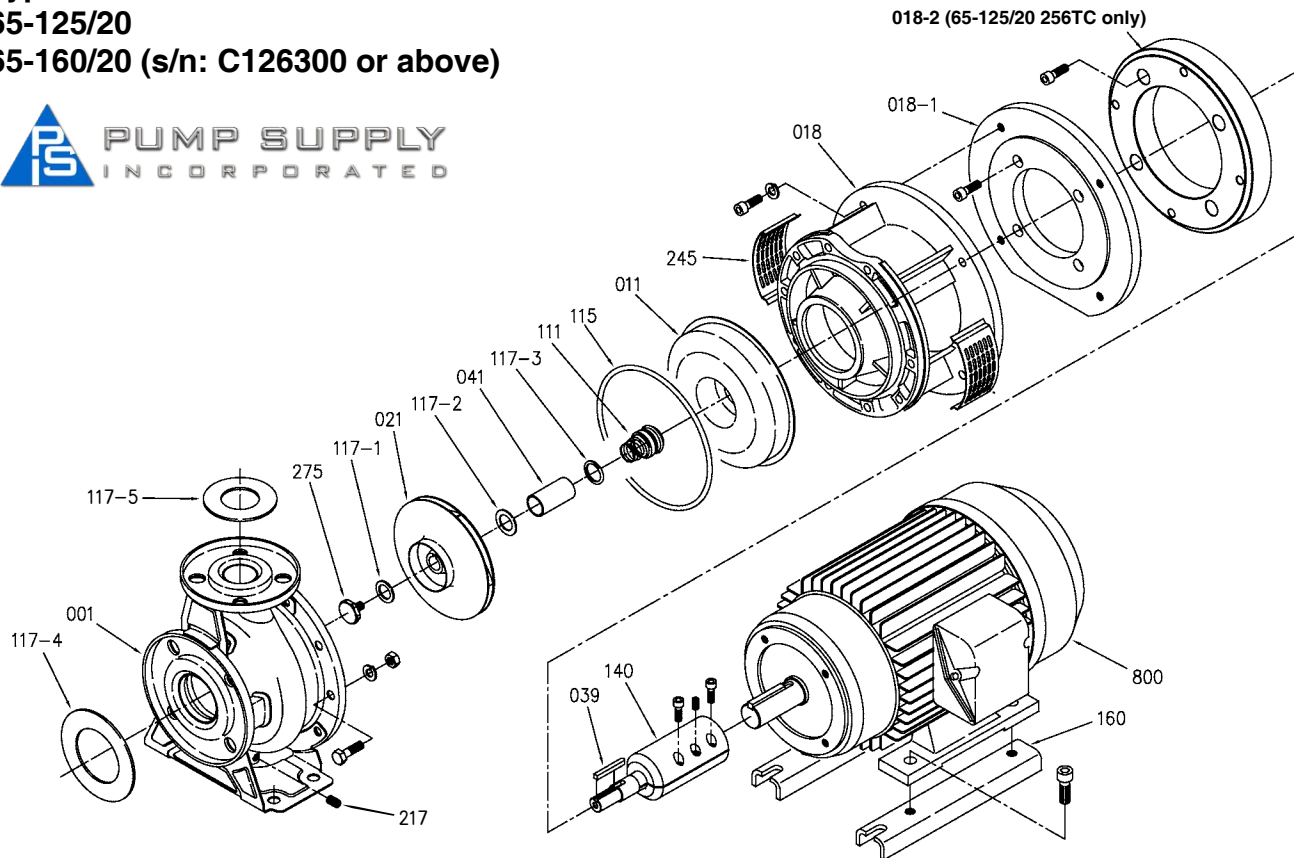

**EBARA Stainless Steel Centrifugal Pumps****Model 3U****Operating, Installation, and Maintenance****3U Type 2****3U-65-125/20****3U-65-160/20 (s/n: C126300 or above)**

Part No.	Part Name	Materials	No. for 1 Unit
001	Casing	304L Stainless	1
011	Casing Cover	304L Stainless	1
018	Bracket	Cast Iron	1
018-1	Adapter Ring	Cast Iron	1
018-2	Adapter Ring (65-125 20hp only)	Cast Iron	1
021	Impeller	304L Stainless	1
039	Key	304L Stainless	1
041	Shaft Sleeve	304L Stainless	1
111	Mechanical Seal	varies by model	1
115	O-Ring	Viton/EPDM	1
117-1	Gasket	Nylon	1
117-2	Gasket	Nylon	1
117-3	Gasket	Nylon	1
117-4	Suction Flange Gasket	EPDM	2
117-5	Discharge Flange Gasket	NBR/EPDM	2
140	Coupling	304L Stainless	1
160	Motor Support	Steel	2
217	Drain Plug	304L Stainless	1
245	Coupling Guard	Stainless Steel	2
275	Impeller Bolt	304L Stainless	1
800	Motor	-	1



**EBARA Stainless Steel Centrifugal Pumps****Model 3U****Operating, Installation, and Maintenance****Model 3U 65 Type 3**

3U 65-160/20 256TC frame (s/n C1-C126299)

3U 65-160/25 284TSC frame

3U 65-200/20 256TC frame

3U 65-200/25 284TSC frame

3U 65-200/30 284TSC frame

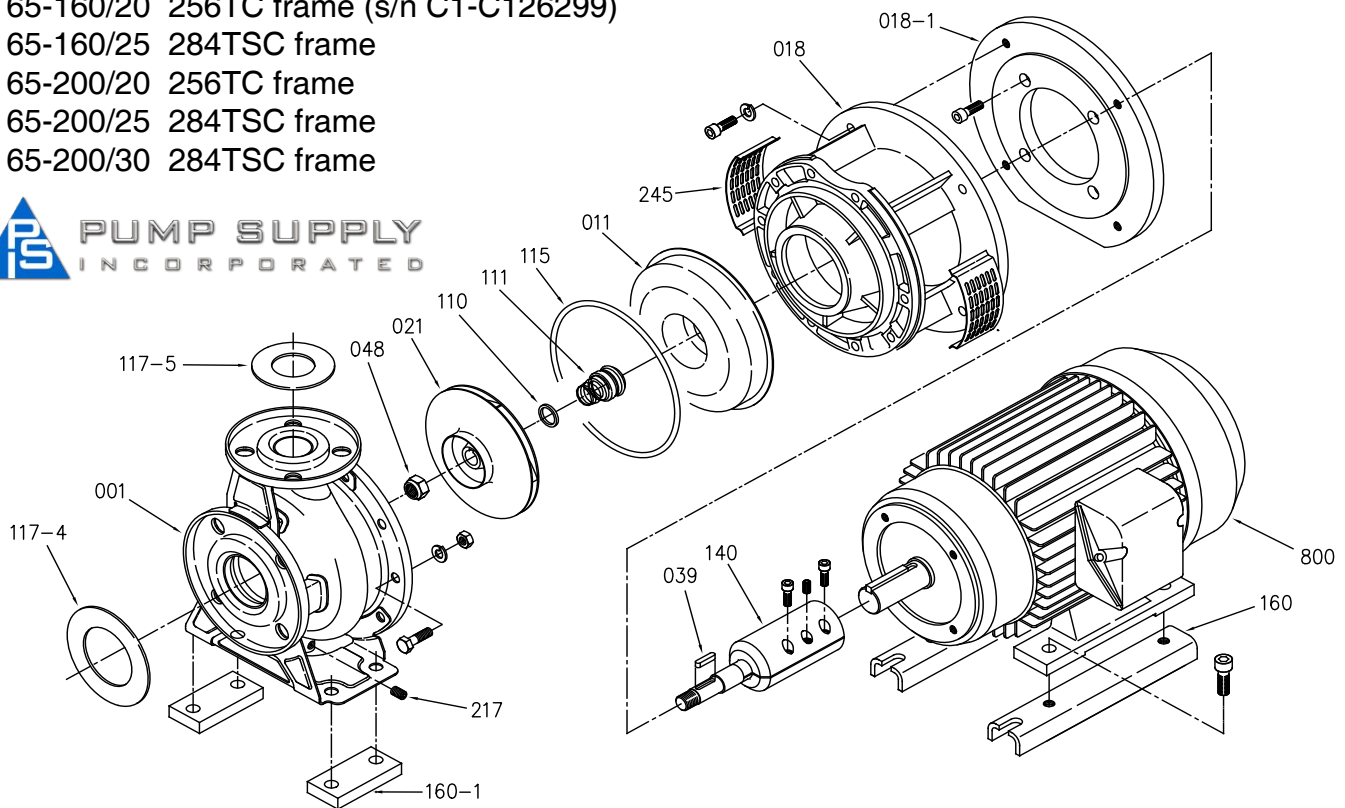

Part No.	Part Name	Materials	No. for 1 Unit
001	Casing	304L Stainless	1
011	Casing Cover	304L Stainless	1
018	Bracket	Cast Iron	1
018-1	Adapter Ring	Cast Iron	1
021	Impeller	304L Stainless	1
039	Key	304L Stainless	1
048	Impeller Nut	Stainless Steel	1
110	Lip Seal	304L Stainless	1
111	Mechanical Seal	varies by model	1
115	O-Ring	Viton/EPDM	1
117-4	Suction Flange Gasket	EPDM	2
117-5	Discharge Flange Gasket	NBR/EPDM	2
140	Coupling	304L Stainless	1
160	Motor Support	Steel	2
160-1	Casing Support	Steel	2
217	Drain Plug	304L Stainless	1
245	Coupling Guard	Stainless Steel	2
800	Motor	-	1



**EBARA Stainless Steel Centrifugal Pumps****Model 3U****Operating, Installation, and Maintenance****3U / Installation Instructions****Mounting the Assembly**

Do not operate the pump unless the assembly is securely and properly mounted.

Misalignment of the motor/pump assembly or not having the assembly reasonably level may cause pump vibration, noisy operation, fluid leaks, or air leaks and air locks in the suction pipe.

1. Place the motor/pump assembly in its intended operating position.
2. Level the pump through the centerline of the motor/pump assembly suction port.

 **WARNING**

**Initial Operation**

Make certain the motor is not connected to a power source until the motor is properly assembled and mounted. Serious personal injury or damage to the motor/pump assembly could occur if the motor is activated improperly.

Only certified electricians should make electrical connections.

1. Prime the pump by adding fluid to the volute case through the top plug. To properly prime the pump, venting may be required.
2. Check the nameplate on the motor to determine the correct wiring procedure for your intended power source and if the motor is single or three phase. Connect the motor to a power source by following the wiring procedure on the motor's nameplate.

**Note:**

- a. Single phase motors are typically dual voltage. In some cases, three phase motors are tri-voltage. Check the name plate and follow the proper wiring procedure for the voltage you are using. Improperly wiring the motor could result in damage to the motor.
- b. Three phase motors require a control box. Install overload protection to help prevent motor damage.
- c. Depending on the wiring, three phase motors may start in reverse. Interchange any two power leads to change the starting direction and pump rotation.
  - Always follow correct operating procedures.
  - Always disconnect the motor/pump assembly from all power sources before servicing the pump or motor.
  - Periodically check all power connections, bolts, screws, and the motor's mounting.
  - Failure to properly follow assembly and operating instructions could result in damage to the pump and motor.
  - Failure to properly install the impeller and impeller nut could result in damage to the pump and could cause serious personal injury.





**EBARA Stainless Steel Centrifugal Pumps****Model 3U****Operating, Installation, and Maintenance****Maintenance****Service**

Keep ventilation openings clear of extraneous objects which may hinder free flow of air thru motor. Motor bearings are lubricated during manufacture. Additional lubrication is not required during their normal lifetime.

 **CAUTION**
**Draining**

The pump and piping should always be protected against freezing temperatures. If there is any danger of freezing, the unit should be drained. To drain the pump, remove the drain plug at the bottom of the volute, and remove the priming plug to vent the pump. Drain all piping.

**Disassembly Instructions**

All pumping parts can be removed from case without disturbing the piping.

 **WARNING**

**POWER SUPPLY-** Open the power supply switch contacts and remove fuses. Disconnect the electrical wiring from the motor

**VOLUTE CASE**

- (a) Drain pump case by removing drain plugs.
- (b) Remove the bolts securing volute case to pump bracket.
- (c) Pry volute case from casing cover with a screwdriver.

**IMPELLER**

- (a) Hold the motor shaft with a screwdriver in the shaft end slot. Grasp and turn the impeller counterclockwise (as viewed from pump end).

**SEAL**

- (a) Remove the rotating part of the seal by pulling it off the shaft.
- (b) The stationary seat can be pressed from the casing cover.

**CHECK LIST FOR EXAMINATION OF PUMP PARTS**

**IMPELLER** - Replace the impeller if any vane is broken, excessive erosion shows, or if labyrinth surfaces are worn. Impeller cap screw, washer and lockwasher should be replaced if damaged.

**MECHANICAL SEAL** - Seal face, o-ring and sealing members should be free of burrs and dirt. Complete seal assembly should be replaced if not in perfect condition.

**SHAFT-** Shaft sleeve surface under seal or packing must be clean, smooth and without any grooves. It should be replaced if necessary.

**VOLUTE AND SEAL/PACKING PLATE LABYRINTH SURFACES (Wear Rings)-** If worn, replace the necessary part. If furnished with pressed in wear rings, only the rings need be replaced.

**GASKETS** - Volute, suction pipe and discharge pipe gaskets should be checked for damage. Replace if necessary.

**NOTE**

If replacement parts are ordered, please furnish the following information to your EBARA distributor:

1. Reference Numbers
2. Description of Pump Part
3. EBARA Model Number and Serial Number on the Nameplate.



**PUMP SUPPLY**  
INCORPORATED

**EBARA Stainless Steel Centrifugal Pumps****Model 3U****Operating, Installation, and Maintenance****3U Assembly Instructions****Type 1- Models 3HP-15HP****! WARNING**

- Make certain the motor is not connected to a power source. Do not install or assemble the pump on a motor that is connected to a power source. Serious injury could occur if the motor activates during assembly.
- Make certain the work surface is level and capable of supporting the motor.
- Take care not to overtighten the bolts, this can cause stripping of the threads.

1. Position the motor (800) on its end with the shaft up.
2. Fasten the motor bracket (018) to the motor. Torque to 8 ft-lbs
3. Position a Nylon gasket (117-3) over the motor shaft.
4. Apply a thin coat of non-petroleum based lubricant (i.e., dish soap) to the casing cover (011) where the stationary seal seats, using finger pressure only, press the stationary seal into the seal seat. (Note: Seal faces should be wiped clean with a non-oil based solvent or alcohol.)
5. Position the O-ring (115) around the casing cover. Make sure not to cut, nick, or damage the O-ring during the installation.
6. Carefully position the casing cover (011) and seal over the shaft and onto the motor bracket (018). Tap the casing cover with a rubber mallet to make sure it completely seats against the motor bracket.
7. Apply a thin coat of non-petroleum based lubricant (i.e., dish soap) to the inside of the rotating seal boot. Carefully press the seal assembly onto the shaft sleeve (041). The smooth face of the rotating ring must make good contact with the seal seat and the seal retainer must seal against the shaft sleeve. (Note: Seal faces should be wiped clean with non-oil based solvent or alcohol.)
8. Slide the stainless steel shaft sleeve (041), with rotating assembly, onto the motor shaft.
9. Install the shaft key (039) into the motor shaft.
10. Place the seal spring assembly over the rotating seal assembly and position to receive the impeller.
11. Place the Nylon gasket (117-2) on top of the spring retainer.
12. 3U 32-125 only: Place the stainless spacer (042) on top of the gasket. Make sure to align the slot in the spacer with the impeller key.
13. Firmly press the impeller (021) into position by aligning the slot over the shaft key. Press the impeller down the shaft until it bottoms out and seats squarely against the Nylon gasket and shaft sleeve.
14. Place the Nylon gasket (117-1) onto the impeller eye. Install the impeller bolt (275) to secure the impeller to the shaft. Do not overtighten the shaft bolt. (Use a thread compound or cement to secure the shaft bolt and prevent it from working loose.) Torque to 11 ft-lbs.
15. Install the casing (001) onto the motor bracket (018). Take care to align the bolt holes. Fasten the casing and make sure to use a cross-tighten pattern. Torque to 8 ft-lbs.
16. With a socket wrench, rotate impeller to check for proper casing alignment. If rubbing against the casing occurs loosen the casing bolts and retighten, taking care to cross-tighten and use equal torque.
17. Install the motor support (160) or casing support (160-1) as required.

**Illinois Location:**

(847) 841-7867

860 Church Rd Elgin, IL 61

**Minnesota Location:**

(651) 758-7867

330 Mill Bay South Suite :

Afton, MN 55001

PumpSupplyInc.com



**EBARA Stainless Steel Centrifugal Pumps****Model 3U****Operating, Installation, and Maintenance****3U Assembly Instructions****Type 2- Models 65-125 & 65-160 20HP**

**WARNING**

- Make certain the motor is not connected to a power source. Do not install or assemble the pump on a motor that is connected to a power source. Serious injury could occur if the motor activates during assembly.
- Make certain the work surface is level and capable of supporting the motor.
- Take care not to overtighten the bolts, this can cause stripping of the threads.

1. Position the motor (800) on its end with the shaft up.
2. Apply a coat of anti-seize lubricant to the inside of the coupling (140).
3. Ensure that the motor key is installed in the motor shaft keyway and slide the coupling (140) onto the shaft. (Tip: To ease the installation of the coupling, tighten the set screw on the side of the coupling. Tightening this screw will cause the coupling to open slightly allowing for easier installation. After the coupling is in place be sure to loosen the set screw to release the pressure allowing the coupling to clamp down on the motor shaft.)
4. Secure the coupling to the motor shaft by tightening the socket head bolts in the side of the coupling. Torque to 11 ft-lbs.
5. For 65-125 20 hp: Fasten adapter ring (018-2) to the motor using a cross-tightening pattern. Torque to 8 ft-lbs., then fasten the second adapter ring (018-1) to the first adapter ring using a cross-tightening pattern. Torque to 8 ft-lbs. For 65-160 20 hp: Fasten the adapter ring (018-1) to the motor using a cross-tightening pattern. Torque to 8 ft-lbs.
6. Fasten the motor bracket (018) to the adapter ring. Torque to 8 ft-lbs.
7. Position a Nylon gasket (117-3) over the coupling shaft.
8. Apply a thin coat of non-petroleum-based lubricant (i.e., dish soap) to the casing cover (011) where the stationary seal seats, using finger pressure only, press the stationary seal into the seal seat. (Note: Seal faces should be wiped clean with a non-oil-based solvent or alcohol.)
9. Position the O-ring (115) around the casing cover. Make sure not to cut, nick, or damage the O-ring during the installation.
10. Carefully position the casing cover (011) and seal over the shaft and onto the motor bracket (018). Tap the casing cover with a rubber mallet to make sure it completely seats against the motor bracket.
11. Apply a thin coat of non-petroleum-based lubricant (i.e., dish soap) to the inside of the rotating seal boot. Carefully press the seal assembly onto the shaft sleeve (041). The smooth face of the rotating ring must make good contact with the seal seat and the seal retainer must seal against the shaft sleeve. (Note: Seal faces should be wiped clean with non-oil-based solvent or alcohol.)
12. Slide the stainless steel shaft sleeve (041), with rotating assembly, onto the coupling shaft (140).
13. Install the impeller shaft key (039) into the coupling shaft.
14. Place the seal spring assembly over the rotating seal assembly and position to receive the impeller.
15. Place the Nylon gasket (117-2) on top of the spring retainer.
16. Firmly press the impeller (021) into position by aligning the slot over the shaft key. Press the impeller down the shaft until it bottoms out and seats squarely against the Nylon gasket and shaft sleeve.
17. Place the Nylon gasket (117-1) onto the impeller eye. Install the impeller bolt (275) to secure the impeller to the shaft. Do not overtighten the shaft bolt. (Use a thread compound or cement to secure the shaft bolt and prevent it from working loose.) Torque to 11 ft-lbs.
18. Install the casing (001) onto the motor bracket (018). Take care to align the bolt holes. Fasten the casing and make sure to use a cross-tightening pattern. Torque to 8 ft-lbs.
19. With a socket wrench, rotate impeller to check for proper casing alignment. If rubbing against the casing occurs loosen the casing bolts and retighten, taking care to cross-tighten and use equal torque.
20. Install the motor support (160) and coupling guards (245).



**PUMP SUPPLY**  
INCORPORATED

**EBARA Stainless Steel Centrifugal Pumps****Model 3U****Operating, Installation, and Maintenance****3U Assembly Instructions****Type 3- Models 25HP-30HP****! WARNING**

- Make certain the motor is not connected to a power source. Do not install or assemble the pump on a motor that is connected to a power source. Serious injury could occur if the motor activates during assembly.
- Make certain the work surface is level and capable of supporting the motor.
- Take care not to overtighten the bolts, this can cause stripping of the threads.

1. Position the motor (800) on its end with the shaft up.
2. Apply a coat of anti-seize lubricant to the inside of the coupling (140).
3. Ensure that the motor key is installed in the motor shaft keyway and slide the coupling (140) onto shaft. (Tip: To ease the installation of the coupling tighten the set screw on the side of the coupling. Tightening this screw will cause the coupling to open slightly allowing for easier installation. After the coupling is in place be sure to loosen the set screw to release the pressure allowing the coupling to clamp down on the motor shaft.)
4. Secure the coupling to the motor shaft by tightening the socket head bolts in the side of the coupling. Torque to 11 ft-lbs.
5. Fasten the adapter ring (018-1) to the motor using a cross-tightening pattern. Torque to 8 ft-lbs.
6. Fasten the motor bracket (018) to the adapter ring. Torque to 8 ft-lbs.
7. Apply a thin coat of non-petroleum-based lubricant (i.e., dish soap) to the casing cover (011) where the stationary seal seats, using finger pressure only, press the stationary seal into the seal seat. (Note: Seal faces should be wiped clean with a non-oil-based solvent or alcohol.)
8. Position the O-ring (115) around the casing cover. Make sure not to cut, nick, or damage the O-ring during the installation.
9. Carefully position the casing cover (011) and seal over the shaft and onto the motor bracket (018). Tap the casing cover with a rubber mallet to make sure it completely seats against the motor bracket.
10. Apply a thin coat of non-petroleum-based lubricant (i.e., dish soap) to the inside of the rotating seal boot. Carefully press the seal assembly onto the coupling, pushing gently until it contacts the stationary seal. (Note: Seal faces should be wiped clean with non-oil-based solvent or alcohol.)
11. Install the impeller shaft key (039) into the coupling shaft.
12. Place the seal spring assembly over the rotating seal assembly and position to receive the impeller.
13. Place the stainless steel lip seal (110) on top of the spring retainer. Make sure the raised surface of the lip seal seats into the spring retainer.
14. Firmly press the impeller (021) into position by aligning the slot over the shaft key. Press the impeller down the shaft until it bottoms out and seats squarely against the Nylon gasket and shaft sleeve.
15. Install the impeller nut (048) to secure the impeller to the shaft. Do not overtighten. Torque to 25 ft-lbs.
16. Install the casing (001) onto the motor bracket (018). Take care to align the bolt holes. Fasten the casing and make sure to use a cross-tighten pattern. Torque to 8 ft-lbs.
17. With a socket wrench, rotate the impeller to check for proper casing alignment. If rubbing against the casing occurs loosen the casing bolts and retighten, taking care to cross-tighten and use equal torque.
18. Install the motor support (160) or casing support (160-1) as required.
19. Install the coupling guards (245).

**Illinois Location:**

(847) 841-7867  
860 Church Rd Elgin, IL 61

**Minnesota Location:**

(651) 758-7867  
330 Mill Bay South Suite  
Afton, MN 55001

PumpSupplyInc.com



**EBARA Stainless Steel Centrifugal Pumps****Model 3U****Operating, Installation, and Maintenance****Flange Loading and Bolt Torque****Flange Loading and Bolt Torque**

Pump Model	Flange	Flange Size	No. of Bolts	Bolt Size	Torque-lb-ft	Torque Nm
3U-32	Suction	2"	4	5/8"	59	80
	Discharge	1 1/4"	4	1/2"	44	60
3U-40	Suction	2 1/2"	4	5/8"	59	80
	Discharge	1 1/2"	4	1/2"	44	60
3U-50	Suction	2 1/2"	4	5/8"	59	80
	Discharge	2"	4	5/8"	59	80
3U-65	Suction	3"	4	5/8"	59	80
	Discharge	2 1/2"	4	5/8"	59	80

Note: Torque values listed above are for non-lubricated 304 SS fasteners.

Caution: Exceeding the torque values above may result in damage to the pump flange.

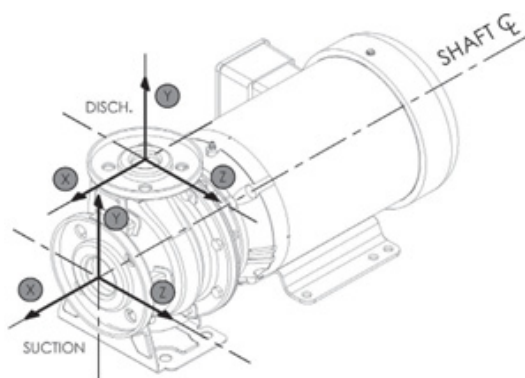

Pump Model		3U-32		3U-40		3U-50		3U-65	
Flange		Suction	Disch.	Suction	Disch.	Suction	Disch.	Suction	Disch.
Flange Size		2"	1 1/4"	2 1/2"	1 1/2"	2 1/2"	2"	3"	2 1/2"
<b>Allowable load applied to the flange</b>									
Fx	N	22	14	33	18	33	22	33	33
	lb	49	31	74	40	74	49	74	74
Fy	N	28	11	41	12	41	18	41	18
	lb	63	25	92	27	92	40	92	40
Fz	N	18	18	28	22	28	28	28	28
	lb	40	40	63	49	63	63	63	63
ΣF	N	40	25	60	31	60	40	60	40
	lb	90	57	134	69	134	90	134	90
<b>Allowable moment applied to the flange</b>									
Mx	Nm	47	24	97	32	97	47	97	47
	lb-ft	347	177	715	236	715	347	715	347
My	Nm	24	12	48	16	48	24	48	24
	lb-ft	177	89	354	118	354	177	354	177
Mz	Nm	36	18	73	24	73	36	73	36
	lb-ft	266	133	538	177	538	266	538	266
ΣM	Nm	64	32	131	43	131	64	131	64
	lb-ft	471	238	963	318	963	471	963	471



**EBARA Stainless Steel Centrifugal Pumps**

**Model 3U**

**Operating, Installation, and Maintenance**

**Troubleshooting**

Trouble	Possible Cause	Troubleshooting
Pump does not run.	Faulty connection of power supply circuit. Wrong wiring of control circuit. Bound shaft. Mechanical seal faces stuck together. Faulty motor. Damage to bearing.	Check power supply circuit. Correct control circuit. Remove cause of obstruction. Release seal by turning shaft. Repair or replace motor. Repair or replace any damaged bearing.
Pump does not pump water. Inadequate quantity.	Considerable voltage drop. Rotation direction reversed. Lack of priming. High discharge head. Large piping loss. Clogged foot valve. Leakage from suction piping. Too high suction lift. Low water level.	Correct rotation direction. Re-prime the pump. Re-examine the plan. Re-examine the plan. Clear foot valve suction Check and repair suction piping. Re-install as per our instructions. Foot valve in ample immersion.
Overcurrent	Considerable fluctuation of power supply voltage. Considerable voltage drop. Low head and overflow rate. Damaged bearing.	Throttle flow rate at outlet. Replace any damage bearing.
Pump vibrates, excessive operating noise	Beyond rated capacity. Cavitation. Improper piping. Damaged bearing. Foreign matter clogging cooling fan.	Reduce flow rate. Consult distributor. Secure piping again. Replace any damaged bearing. Remove foreign matter.
Pressurizing application. Pump starts and soon stops.	Too limited pressure switch setting.	Replace pressure switch to wider range. Check and repair leaks.
Pumps does not stop.	Leakage in system. Too high pressure setting.	Reduce max pressure setting to the lower in pressure switch.

**MAINTENANCE:**

The pump does not require special maintenance.

The following rules must be observed for safe operation:

If the pump is not going to be used for a long period, the pump should be drained of water and flushed with clean water.

Where the pump is exposed to freezing temperatures, it should always be left drained when not in use.

\*All specifications subject to change without notice.

**Illinois Location:**  
(847) 841-7867  
860 Church Rd Elgin, IL 60120

**Minnesota Location:**  
(651) 758-7867  
330 Mill Bay South Suite :  
Afton, MN 55001

PumpSupplyInc.com



**PS** **PUMP SUPPLY**  
INCORPORATED



**Illinois Location:**  
(847) 841-7867  
860 Church Rd Elgin, IL 60120

**Minnesota Location:**  
(651) 758-7867  
330 Mill Bay South Suite  
Afton, MN 55001

PumpSupplyInc.com



The image shows a map of the United States with two stars indicating office locations: one in Illinois and one in Minnesota. Below the map is the logo for Pump Supply Incorporated, which consists of a blue triangle containing the letters 'PS' in white, followed by the text 'PUMP SUPPLY' in a large, bold, sans-serif font, and 'INCORPORATED' in a smaller, spaced-out, sans-serif font below it.

