

**INSTALLATION & SERVICE**

**D15-991-2400A**

# **Hydra-Cell<sup>®</sup>**

## **INDUSTRIAL PUMPS**

**Models: D-15, G-15**

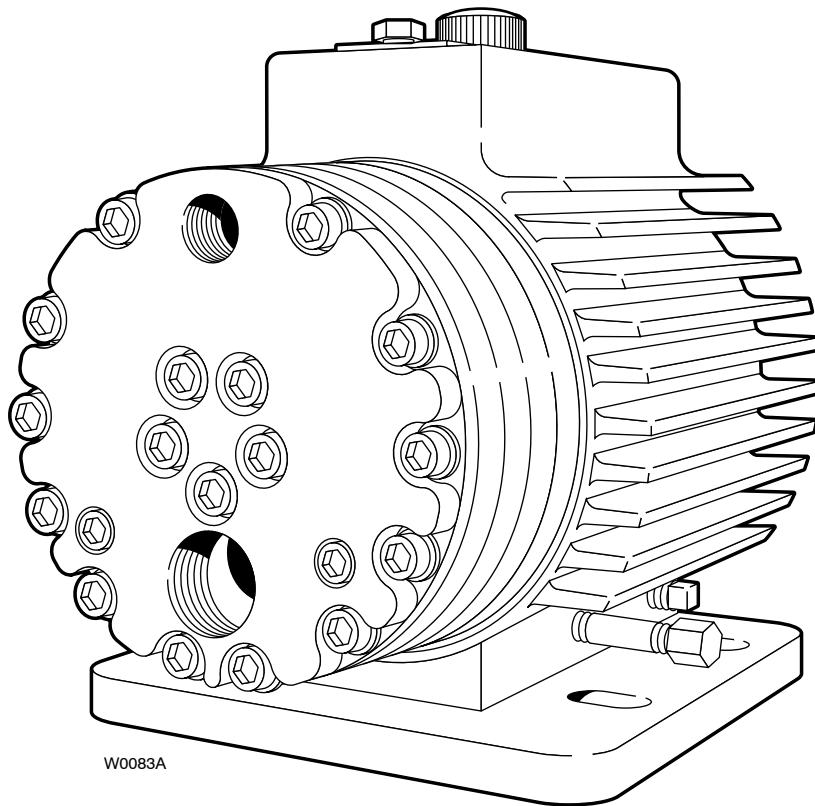

**WANNER ENGINEERING, INC.**

1204 Chestnut Avenue, Minneapolis, MN 55403

TEL: (612) 332-5681 FAX: (612) 332-6937

TOLL-FREE FAX [US only]: (800) 332-6812

[www.hydra-cell.com](http://www.hydra-cell.com)

email: [sales@wannereng.com](mailto:sales@wannereng.com)

# D/G-15 Contents

	Page
Specifications.....	2
Dimensions .....	4
Installation.....	6
Maintenance.....	10
Service (Fluid End) .....	11
Service (Hydraulic End) .....	15
Troubleshooting.....	18
Warranty.....	20

## D/G-15 Specifications

### Max Pressure

1500 psi (100 bar) @ 1750 rpm  
(D/G-15-E Cam only);  
2000 psi (140 bar) @ 1450 rpm;  
2500 psi (170 bar) @ 1150 rpm

### Capacity @ Rated Pressure

	rpm	psi	bar	gpm	l/min
D/G-15-X	1450	500	35	13.4	50
	1450	1500	100	13.0	48
	1450	2000	140	12.7	48
	1150	2500	170	10.3	389
D/G-15-E	1750	500	35	15.1	57
	1750	1500	109	14.1	53
	1450	2000	140	11.5	44
	1150	2500	170	9.4	35

### Delivery @ Rated Pressure

	psi	bar	revs/gal	
D/G-15-X	500	34.5	109	28.8
	1500	103.5	112	29.6
	2000	138	114	30.2
	2500	172	117	30.9
D/G-15-E	500	34.5	116	20.6
	1500	103.5	124	32.8
	2000	138	126	33.3
	2500	172	128	33.7

**Max Inlet Pressure** 500 psi (35 bar)

**Max Temperature** 250°F (121°C) – consult factory for temperatures above 180°F (82°C)

**Inlet Port** D-15: 1-1/4 inch NPT  
G-15: 1-1/4 inch BSPT

**Discharge Port** D-15: 3/4 inch NPT  
G-15: 3/4 inch BSPT

**Shaft Diameter** 1-1/8 inch (28.58 mm)

**Shaft Rotation** Bi-directional

**Bearings** Tapered roller bearings

**Oil Capacity** 2.2 US quarts (2.1 liters)

**Weight** 145 lbs (66 kg)

### Calculating Required Horsepower (kW)\*

$$\frac{80 \times \text{rpm}}{63,000} + \frac{\text{gpm} \times \text{psi}}{1,460 - \left(\frac{\text{psi} - 500}{20}\right)} = \text{electric motor HP}^*$$

$$\frac{80 \times \text{rpm}}{84,428} + \frac{\text{gpm} \times \text{bar}}{511 - \left(\frac{\text{bar} - 35}{4}\right)} = \text{electric motor kW}^*$$

\* rpm equals pump shaft rpm. HP/kW is required application power. Use caution when sizing motors with variable speed drives.

# D/G-15 Specifications

## Performance

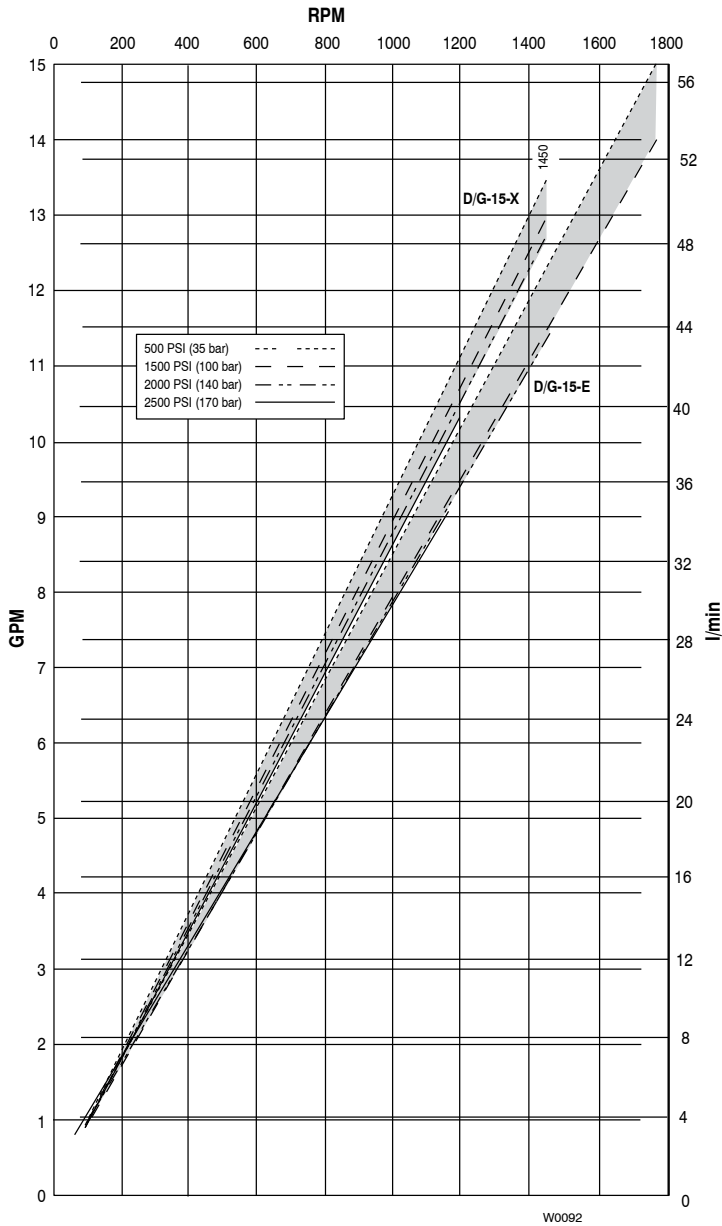

\*Pump NPSHr and Lift performance based on randomly selected pumps with water at 70°F (21°C)

## Net Positive Suction Head – NPSHr

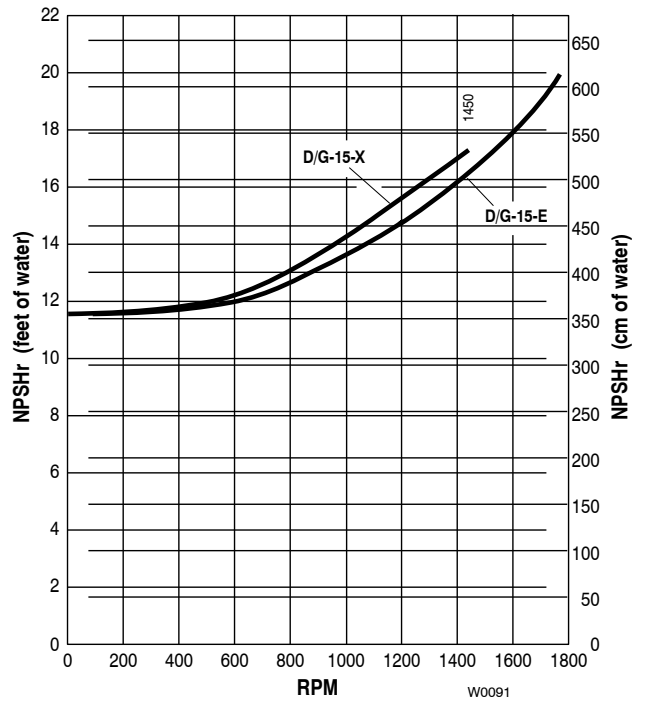

## Dry Lift

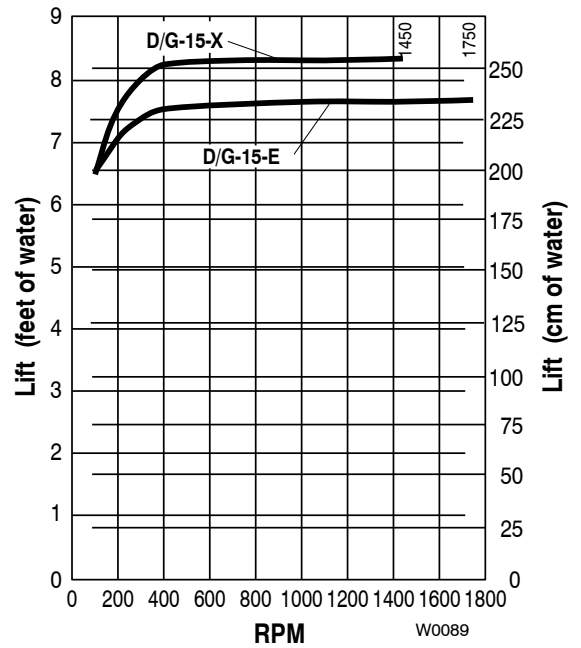

# D/G-15 Dimensions

## D/G-15 Models without Pump/Motor Adapter

Brass

316 Stainless Steel

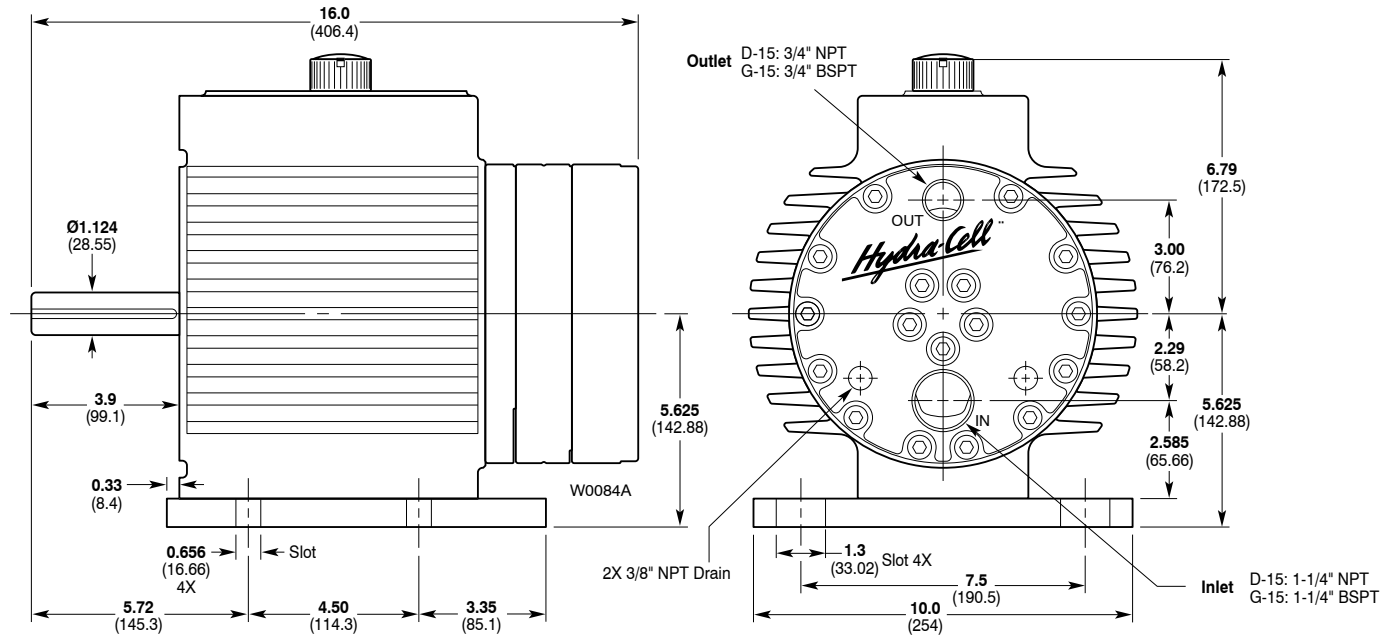

# D/G-15 Dimensions

## D/G-15 Models with Pump/Motor Adapter

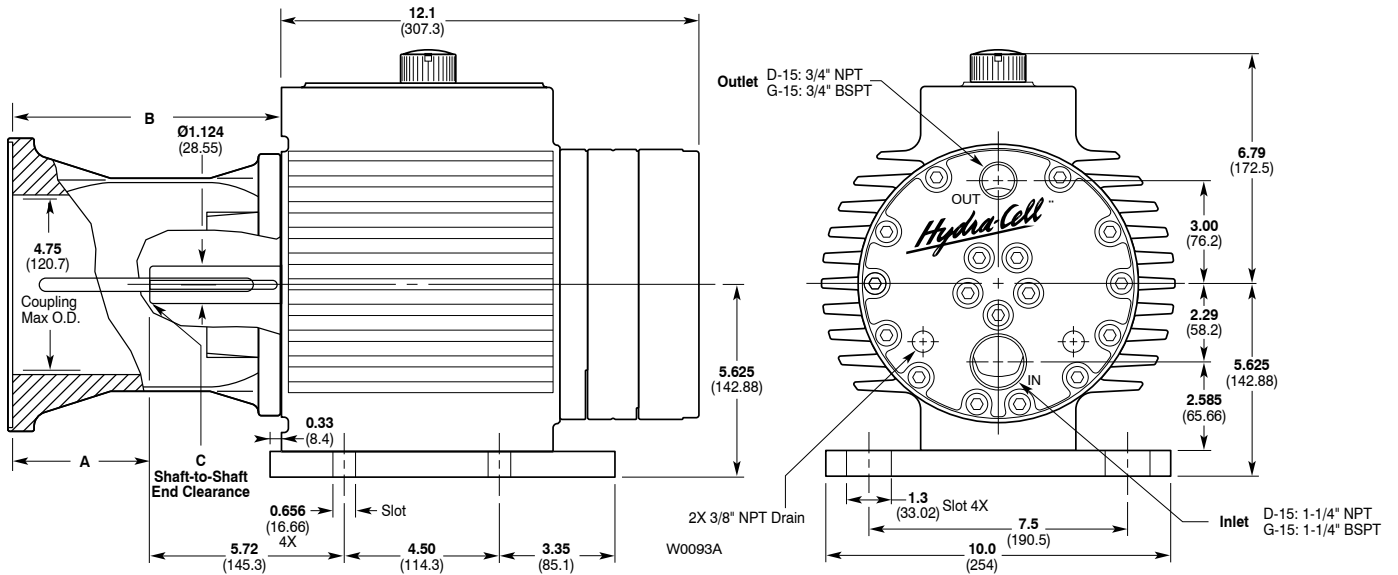

Motor Frame Size	Dimensions in (mm)		
	A	B	C
NEMA 182TC/184TC	4.1 (104)	8.0 (203)	1.71 (43.4)
NEMA 213TC/215TC	4.1 (104)	8.0 (203)	0.96 (24.4)
NEMA 254TC/256TC	4.1 (104)	8.0 (203)	0.33 (8.4)
NEMA 284TC/286TC	4.5 (114)	8.4 (213)	0.14 (3.6)
IEC 132 (B5 Flange)	4.1 (104)	8.0 (203)	1.09 (27.7)
IEC 160 (B14 Face)	4.3 (109)	8.2 (208)	0.15 (3.8)
IEC 160/180 (B5 Flange)	4.3 (109)	8.2 (208)	0.15 (3.8)

# DG-15 Installation

## Location

**NOTE:** The numbers in parentheses are the Reference Numbers on the exploded view illustrations found later in this manual and in the Parts Manual.

Locate the pump as close to the supply source as possible.

Install it in a lighted, clean space where it will be easy to inspect and maintain. Allow room for checking the oil level, changing the oil, and removing the pump head (manifold, valve plate and related items).

## Mounting

The pump shaft can be rotated in either direction.

To prevent vibration, securely attach the pump and motor to a level, rigid base.

On a belt-drive system, align the sheaves accurately: poor alignment wastes horsepower and shortens the belt and bearing life. Make sure the belts are properly tightened, as specified by the belt manufacturer.

On a direct-drive system, align the shafts accurately. Unless otherwise specified by the coupling manufacturer, maximum parallel misalignment should not exceed .015" and angular misalignment should be held to 1 degree maximum. Careful alignment extends life of the coupling, pump, shafts, and support bearings. Consult coupling manufacturer for exact alignment tolerances.

## Important Precautions

**Adequate Fluid Supply.** To avoid cavitation and premature pump failure, be sure that the pump will have an adequate fluid supply and that the inlet line will not be obstructed. See "Inlet Piping".

**Positive Displacement.** This is a positive-displacement pump. To avoid severe system damage if the discharge line ever becomes blocked, install a relief valve downstream from the pump. See "Discharge Piping".

**Safety Guards.** Install adequate safety guards over all pulleys, belts, and couplings. Follow all codes and regulations regarding installation and operation of the pumping system.

**Shut-Off Valves.** Never install shut-off valves between the pump and discharge pressure regulator, or in the regulator bypass line.

**Freezing Conditions.** Protect the pump from freezing. See also the Maintenance Section.

Consult the Factory for the following situations:

- Extreme temperature applications (above 160° F or below 40° F)
- Pressure feeding of pumps
- Viscous or abrasive fluid applications
- Chemical compatibility problems
- Hot ambient temperatures (above 110° F)
- Conditions where pump oil may exceed 200° F because of a combination of hot ambient temperatures, hot fluid temperature, and full horsepower load — an oil cooler may be required

# D/G-15 Installation

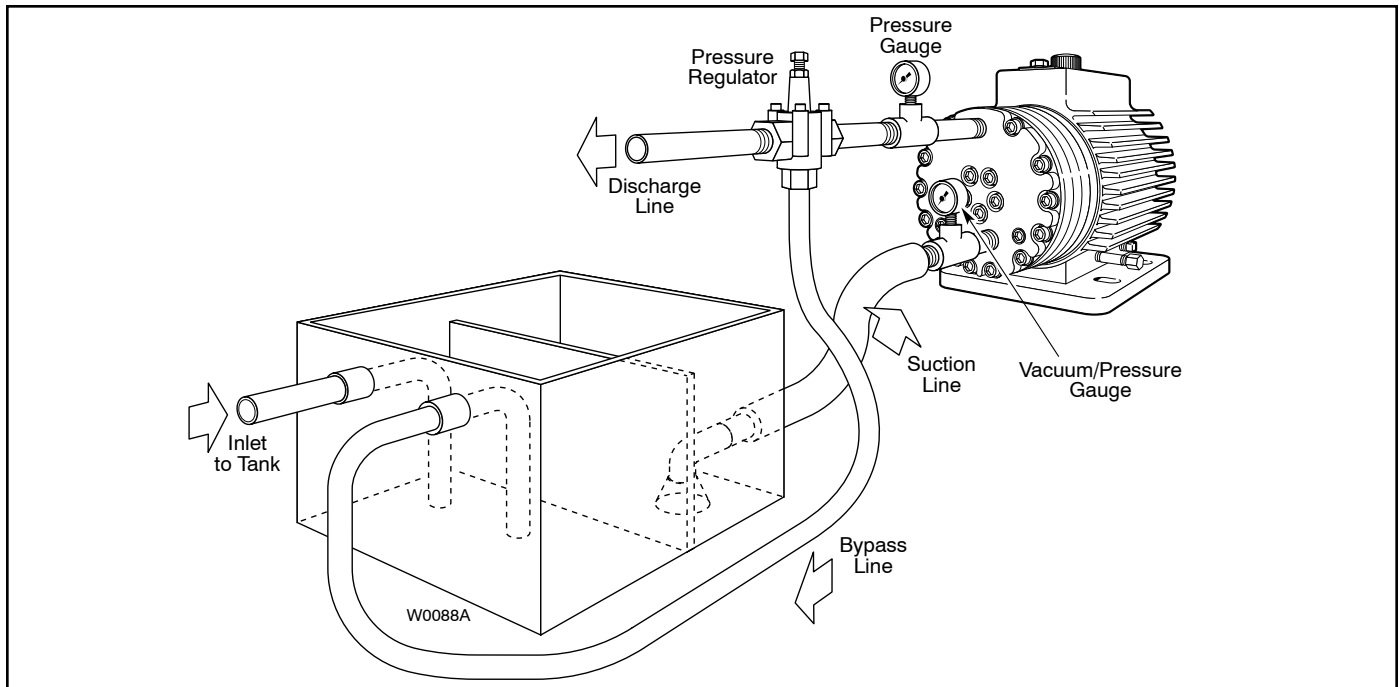

## Inlet Piping (Suction Feed)

**CAUTION: When pumping at temperatures above 160° F (71° C), use a pressure-feed system.**

Install draincocks at any low points of the suction line, to permit draining in freezing conditions.

Provide for permanent or temporary installation of a vacuum gauge to monitor the inlet suction. To maintain maximum flow, vacuum at the pump inlet should not exceed 7 in. Hg at 70° F (180 mm Hg at 21° C). **Do not supply more than one pump from the same inlet line.**

## Supply Tank

Use a supply tank that is large enough to provide time for any trapped air in the fluid to escape. The tank size should be at least twice the maximum pump flow rate.

Isolate the pump and motor stand from the supply tank, and support them separately.

Install a separate inlet line from the supply tank to each pump.

Install the inlet and bypass lines so they empty into the supply tank below the lowest water level, on the opposite side of the baffle from the pump suction line.

If a line strainer is used in the system install it in the inlet line to the supply tank.

To reduce aeration and turbulence, install a completely submerged baffle plate to separate the incoming and outgoing liquids.

Install a vortex breaker in the supply tank, over the outlet port to the pump.

Place a cover over the supply tank, to prevent foreign objects from falling into it.

## Hose and Routing

Size the suction line at least one size larger than the pump inlet, and so that the velocity will not exceed 1-3 ft/sec (0.3 to 0.9 m/s):

For pipe in inches: Velocity (ft/sec) =  $0.408 \times \text{GPM} / \text{Pipe ID}^2$

For pipe in mm: Velocity (m/sec) =  $21.2 \times \text{LPM} / \text{Pipe ID}^2$

Keep the suction line as short and direct as possible. A maximum of 3 feet (1 m) is recommended.

Use flexible hose and/or expansion joints to absorb vibration, expansion, or contraction.

If possible, keep the suction line level. Do not have any high points to collect vapor unless these high points are vented.

To reduce turbulence and resistance, do not use 90° elbows. If turns are necessary in the suction line, use 45° elbows or arrange sweeping curves in the flexible inlet hose.

If a block valve is used, be sure it is fully opened so that the flow to the pump is not restricted. The opening should be at least the same diameter as the inlet plumbing ID.

Do not use a line strainer or filter in the suction line unless regular maintenance is assured. If used, it should have a free-flow area of at least three times the free-flow area of the inlet.

Install piping supports where necessary to relieve strain on the inlet line and to minimize vibration.

## Inlet Piping (Pressure Feed)

Provide for permanent or temporary installation of a vacuum/pressure gauge to monitor the inlet vacuum or pressure. Pressure at the pump inlet should not exceed 500 psi (34.5 bar); if it could get higher, install an inlet pressure reducing regulator.

**Do not** supply more than one pump from the same inlet line.

# D/G-15 Installation

## Inlet Calculations

### Acceleration Head

#### Calculating the Acceleration Head

Use the following formula to calculate acceleration head losses. Subtract this figure from the NPSHa, and compare the result to the NPSHr of the Hydra-Cell pump.

$$H_a = (L \times V \times N \times C) \div (K \times G)$$

where:

H<sub>a</sub> = Acceleration head (ft of liquid)

L = Actual length of suction line (ft) — not equivalent length

V = Velocity of liquid in suction line (ft/sec) [V = GPM x (0.408 ÷ pipe ID<sup>2</sup>)]

N = RPM of crank shaft

C = Constant determined by type of pump — use 0.04 for the D-15 and G-15 Hydra-Cell pumps

K = Constant to compensate for compressibility of the fluid — use: 1.4 for de-aerated or hot water; 1.5 for most liquids; 2.5 for hydrocarbons with high compressibility

G = Gravitational constant (32.2 ft/sec<sup>2</sup>)

### Friction Losses

#### Calculating Friction Losses in Suction Piping

When following the above recommendations (under “inlet Piping”) for minimum hose/pipe I.D. and maximum length, frictional losses in the suction piping are negligible (i.e., H<sub>f</sub> = 0) if you are pumping a water-like fluid.

When pumping more-viscous fluids such as lubricating oils, sealants, adhesives, syrups, varnishes, etc., frictional losses in the suction piping may become significant. As H<sub>f</sub> increases, the available NPSH (NPSHa) will decrease, and cavitation will occur.

In general, frictional losses increase with increasing viscosity, increasing suction-line length, increasing pump flowrate, and decreasing suction-line diameter. Changes in suction-line diameter have the greatest impact on frictional losses: a 25% increase in suction-line diameter cuts losses by more than two times, and a 50% increase cuts losses by a factor of five times.

Consult the factory before pumping viscous fluids.

#### Minimizing Acceleration Head and Frictional Losses

To minimize the acceleration head and frictional losses:

- Keep inlet lines less than 3 ft (1 m) long
- Use at least 1-1/2 in. (38 mm) I.D. inlet hose
- Use soft hose (low-pressure hose, noncollapsing) for the inlet lines
- Minimize fittings (elbows, valves, tees, etc.)
- **Use a suction stabilizer on the inlet.**

## Net Positive Suction Head

NPSHa must be equal to or greater than NPSHr. If not, the pressure in the pump inlet will be lower than the vapor pressure of the fluid— and cavitation will occur.

### Calculating the NPSHa

Use the following formula to calculate the NPSHa:

$$NPSHa = P_t + H_z - H_f - H_a - P_{vp}$$

where:

P<sub>t</sub> = Atmospheric pressure

H<sub>z</sub> = Vertical distance from surface liquid to pump centerline (if liquid is below pump centerline, the H<sub>z</sub> is negative)

H<sub>f</sub> = Friction losses in suction piping

H<sub>a</sub> = Acceleration head at pump suction

P<sub>vp</sub> = Absolute vapor pressure of liquid at pumping temperature

NOTES:

- In good practice, NPSHa should be 2 ft greater than NPSHr
- All values must be expressed in feet of liquid

### Atmospheric Pressure at Various Altitudes

Altitude (ft)	Pressure (ft of H <sub>2</sub> O)	Altitude (ft)	Pressure (ft of H <sub>2</sub> O)
0	33.9	1500	32.1
500	33.3	2000	31.5
1000	32.8	5000	28.2

## Discharge Piping

**NOTE: Consult the Factory before manifolding two or more pumps together.**

### Hose and Routing

Use the shortest, most-direct route for the discharge line.

Select pipe or hose with a **working pressure** rating of at least 1.5 times the maximum system pressure. EXAMPLE: Select a 3000-psi W.P.-rated hose for systems to be operated at 2000-psi-gauge pressure.

Use about 6 ft (1.8 m) of flexible hose between the pump and rigid piping to absorb vibration, expansion or contraction.

Support the pump and piping independently. Size the discharge line so that the velocity of the fluid will not exceed 7-10 ft/sec (2-3 m/sec):

$$\text{For pipe in inches: Velocity (ft/sec) = } 0.408 \times \text{GPM/Pipe ID}^2$$

$$\text{For pipe in mm: Velocity (m/sec) = } 21.2 \times \text{LPM/Pipe ID}^2$$



# D/G-15 Installation

## Pressure Regulation

**Install a pressure regulator or unloader in the discharge line.** Bypass pressure must not exceed the pressure limit of the pump.

Size the regulator so that, when fully open, it will be large enough to relieve the full capacity of the pump without overpressurizing the system.

Locate the valve as close to the pump as possible and ahead of any other valves.

Adjust the pressure regulating valve to no more than 10% over the maximum working pressure of the system. Do not exceed the manufacturer's pressure rating for the pump or regulator.

Route the bypass line to the supply tank, or to the suction line as far as possible from the pump (to reduce the chance of turbulence and cavitation).

If the pump may be run for a long time with the discharge closed and fluid bypassing, install a thermal protector in the bypass line (to prevent severe temperature buildup in the bypassed fluid).

**CAUTION: Never install shutoff valves in the bypass line or between the pump and pressure regulator or relief valve.**

Provide for permanent or temporary installation of a pressure gauge to monitor the discharge pressure at the pump.

For additional system protection, install a safety relief valve in the discharge line, downstream from the pressure regulator.

## Before Initial Start-Up

Before you start the pump, be sure that:

- All shutoff valves are open, and the pump has an adequate supply of fluid.
- All connections are tight.
- The oil level is 1/4 in. (6 mm) above the cast surface in the upper oil reservoir.
- The relief valve on the pump outlet is adjusted so the pump starts under minimum pressure.
- All pulleys and belts are properly aligned, and belts are tensioned according to specification.
- All pulleys, belts and shaft couplings have adequate safety guards.

## Initial Start-Up Procedure

1. Turn on power to the pump motor.
2. Check the inlet pressure or vacuum. To maintain maximum flow, inlet vacuum must not exceed 7 in. Hg at 70° F (180 mm Hg at 21° C). Inlet pressure must not exceed 500 psi (34.5 bar).
3. Listen for any erratic noise, and look for unsteady flow. If the pump does not clear, refer to the Trouble-shooting Section.
4. If the system has an air lock and the pump fails to prime:
  - a. Turn off the power.
  - b. Remove the pressure gauge or plug from the tee fitting at the pump outlet (refer to the illustration on page 3).

**NOTE: Fluid may come out of this port when the plug is removed. Provide an adequate catch basin for fluid spillage, if required. Fluid will come out of this port when the pump is started, so we recommend that you attach adequate plumbing from this port so fluid will not be sprayed or lost. Use high-pressure-rated hose and fittings from this port. Take all safety precautions to assure safe handling of the fluid being pumped.**
  - c. Jog the system on and off until the fluid coming from this port is air-free.
  - d. Turn off the power.
  - e. Remove the plumbing that was temporarily installed, and reinstall the pressure gauge or plug.
5. Adjust the discharge pressure regulator to the desired operating and bypass pressures. Do not exceed the maximum pressure rating of the pump.
6. After the pressure regulator is adjusted, set the safety relief valve at 100 psi (7 bar) higher than the desired operating pressure. To verify this setting, adjust the discharge pressure regulator upward until the relief valve opens. Follow the recommendations in the above NOTE (step 4b) for handling the fluid that will come from the relief valve.
7. Reset the discharge pressure regulator to the desired system pressure.
8. Provide a return line from the relief valve to the supply tank, similar to the bypass line from the pressure regulator.

# D/G-15 Maintenance

**NOTE:** The numbers in parentheses are the Reference Numbers on the exploded view illustrations found later in this manual and in the Parts Manual.

## Daily

Check the oil level and the condition of the oil. The oil level should be 1/4 in. (6 mm) above the cast surface in the upper oil reservoir.

Use the appropriate Hydra-Oil for the application (contact Wanner Engineering if in doubt).

**CAUTION:** If you are losing oil but don't see any external leakage, or if the oil becomes discolored and contaminated, one of the diaphragms (21) may be damaged. Refer to the Fluid-End Service Section. Do not operate the pump with a damaged diaphragm.

**CAUTION:** Do not leave contaminated oil in the pump housing or leave the housing empty. Remove contaminated oil as soon as discovered, and replace it with clean oil.

## Periodically

Change the oil after the first 100 hours of operation, then change according to the guidelines below. When changing, remove the drain plug cap (26) at the bottom of the pump so all oil and accumulated sediment will drain out. Then, remove the magnetic plug (33) and clean all accumulated debris from it. Replace the magnetic plug and drain plug cap and refill with the appropriate Hydra-Oil.

### Hours Between Oil Changes @ Various Process Fluid Temperatures

Pressure	RPM	<90°F (32°C)	<139°F (60°C)	<180°F (82°C)
<1500 psi (100 bar)	<1200	4,000	3,000	2,000
	<1750	2,000	1,500	1,000
<2000 psi (140 bar)	<1200	2,000	—	1,500
	<1450	1,500	—	1,000
<2500 psi (170 bar)	<1200	1,500	—	1,000

**NOTE:** Minimum oil viscosity for proper hydraulic end lubrication is 16-20 cST (80-100 SSU).

**NOTE:** Use of an oil cooler is recommended when process fluid and/or hydraulic end oil exceeds 180°F (82°C).

**CAUTION:** Do not turn the drive shaft while the oil reservoir is empty.

Check the inlet pressure or vacuum periodically with a gauge. If vacuum at the pump inlet exceeds 7 in. Hg (180 mm Hg), check the inlet piping system for blockages. If the pump inlet is located above the supply tank, check the fluid supply level and replenish if too low.

**CAUTION:** Protect the pump from freezing. Refer also to the "Shutdown Procedure".

## Shutdown Procedure During Freezing Temperatures

Take all safety precautions to assure safe handling of the fluid being pumped. Provide adequate catch basins for fluid drainage and use appropriate plumbing from drain ports, etc. when flushing the pump and system with a compatible antifreeze.

1. Adjust the discharge pressure regulating valve so the pump runs under minimum pressure. Stop the pump.
2. Drain supply tank; open any draincocks in system piping and collect drainage; remove plugs (0) from manifold and collect drainage.
3. Close draincocks in system piping and replace manifold plugs.
4. Fill supply tank with enough antifreeze to fill system piping and pump.  
Note: disconnect the system return line from the supply tank and connect it to a separate reservoir.
5. Start the pump and allow it to run until the system is filled with antifreeze. Note: if the system has an airlock and the pump fails to prime, follow step 4 of the Initial Start-up Procedure to clear the air.
6. When mostly antifreeze is flowing from the system return line stop the pump. Connect the system return line back to the supply tank and circulate the antifreeze for a short period.
7. It is also good practice to change the oil in the Hydraulic End before storage for an extended period. This will remove any accumulated condensation and sediment from the oil reservoir. Drain and refill the Hydraulic End with the appropriate Hydra-Oil and operate the pump for a short period to assure smooth performance.

# D/G-15 Service (Fluid End)

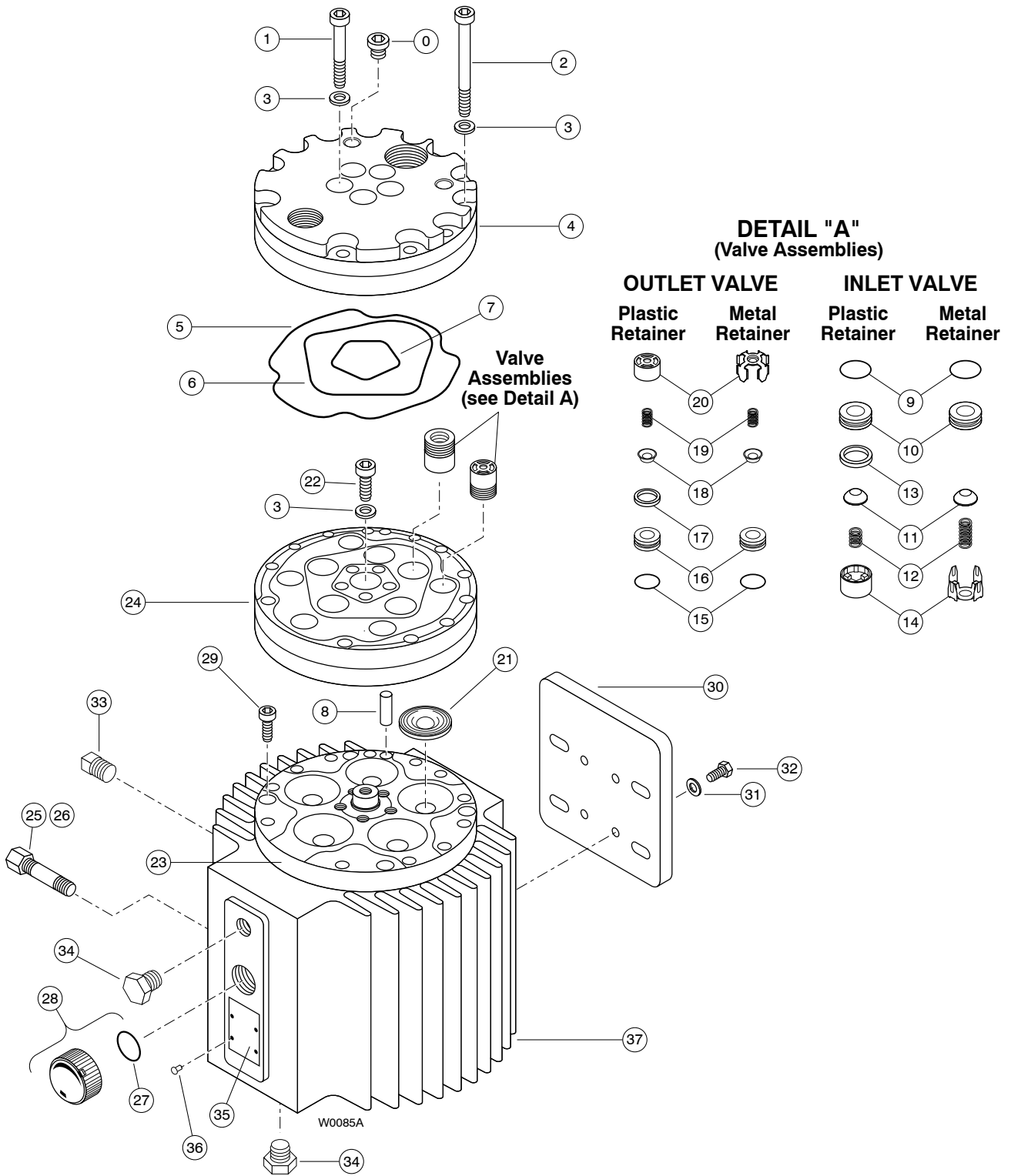

# D/G-15 Service (Fluid End)

**NOTE:** The number in parentheses are the Reference numbers on the illustration on the preceding page and in the Parts Manual.

This section explains how to disassemble and inspect all easily serviceable parts of the pump. Repair procedures for the hydraulic end (oil reservoir) of the pump are included in a later section of the manual.

**CAUTION:** Do not disassemble the hydraulic end unless you are a skilled mechanic. For assistance, contact Wanner Engineering (TEL 612-332-5681 or FAX 612-332-6937) or the distributor in your area.

**CAUTION:** Don not remove the four socket-head capscrews (29) that go through the cylinder housing (23), unless you are repairing the hydraulic end of the pump.

## Tools and Supplies

The following tools and supplies are recommended for servicing the pump:

- Straightedge (at least 8 in. long)
- Grease or petroleum jelly
- 1/2" drive torque wrench, rated to at least 50 ft-lbs (70 N-m)
- Emery cloth and Scotch-Brite™ pad
- 11/16" socket (3/8" or 1/2" drive)
- 19 mm socket (1/2" drive)
- 3/8" drive socket wrench with extensions
- 1/2" drive socket wrench with extensions
- 5/16" (8 mm) open-end wrench
- Wanner Hydra-Oil (appropriate Grade, as determined by digit 12 of your pump model number).
- Anaerobic seal sealant (for shaft seals if servicing Hydraulic End)
- Wanner D-15 Tool Kit, which includes the following:
  - Valve seat puller
  - Plunger guide lifter
  - 3/32 x 6 in. T-handle hex wrench
  - 8 mm hex bit socket (1/2" drive)
  - Shaft rotator
  - Seal protector
  - Seal inserter
  - 5/16" hex Allen wrench
  - 7/16" 8-point socket (3/8" drive)
  - 6 mm hex Allen wrench

## Service Procedures

### 1. Remove Manifold and Valve Plate (4, 24)

- a. **Manifold.** Use the 8 mm hex bit socket included in the Wanner D-15 Tool Kit to remove the 12 capscrews (2) and five capscrews (1) at the front of the manifold. Remove and inspect the manifold for warping or wear around the inlet and outlet ports and flow channels. If wear is excessive replace the manifold. To check if the manifold is warped, place a straightedge across it; check both sides. A warped manifold should be replaced.
- b. **Valve Plate.** Using the 8 mm hex bit socket remove capscrew (22). Remove and inspect the valve plate in the same manner as the manifold, for excessive wear or warping. Replace if necessary.

**CAUTION:** Don't turn the pump drive shaft while the manifold and valve plate are off the pump, except when removing diaphragms or repriming the hydraulic cells.

### 2. Remove and Inspect Valves (9-20)

**NOTE:** Wanner Valve Kits include items and all O-rings for sealing the manifold to the valve plate. The five inlet and five outlet valve assemblies are different in size and face in opposite directions.

- a. Remove the inlet valve seat (10) using the seat puller tool included in the Wanner D-15 Tool Kit. Inspect the valve seat for wear, and replace if necessary.

**NOTE:** Whenever any valve or seat is replaced it is recommended to replace all valve assemblies to ensure the most reliable operation. All necessary parts are included in a replacement Valve Kit.
- b. Remove the remaining inlet valve components (11-14) and outlet valve components (17-20) by hand or with a small needle nose pliers.
- c. Check the spring retainers (14, 20) and replace if worn, cracked, or damaged.
- d. Check the valve springs (12, 19) and replace if worn, broken, or shorter than a new spring. Never attempt to stretch a used spring.
- e. Check the valves (11, 18) for wear or damage and replace if necessary. Polishing of the valves during operation is normal. If you can feel a ridge in the valve surface the valve should be replaced.

**NOTE:** Pumps with plastic spring retainers (14, 20) include a Tetra Seal (13, 17 - square section O-ring) between the spring retainer and valve seat. Pumps with metal spring retainers do not include a Tetra Seal.

# D/G-15 Service (Fluid End)

- f. Reinstall the valve assemblies:
  - Clean the valve ports and shoulders in the valve plate (24) with a Scotch-Brite pad or fine emery cloth. Wash the valve plate after cleaning, and lubricate the valve ports with a compatible grease, oil, or petroleum jelly.
  - Install new O-rings (9, 15) on seats (10, 16) and lubricate all O-rings.
  - Inlet Valves (five center, larger valves). Insert the spring retainer (14) into the valve plate (24), followed by the Tetra seal (13) if spring retainer is plastic. Insert the spring (12) into the retainer, followed by the valve (11) onto the spring. Finally, insert seat (10) with new O-ring into the valve bore with the larger I.D. chamfer (seating surface) facing down, towards the valve.
  - Outlet Valves (five outer, smaller valves). Insert the outlet seat (16) with new O-ring into the valve bore with the larger I.D. chamfer (seating surface) facing up. Insert a Tetra Seal (17) if valve spring retainers are plastic. Insert the valve (18) and spring (19) onto the seat. Finally, insert the spring retainer (20) into the valve bore.
  - Make sure the springs are all properly nested into the spring retainers to ensure proper valve performance.

## 3. Inspect and Replace Diaphragms (21)

- a. Lift a diaphragm by one edge, and turn the pump shaft until the diaphragm moves up to “top dead center”. This will expose machined cross-holes in the valve plunger (51) behind the diaphragm.
- b. Insert a 3/32 x 6 in. hex wrench through one of the machined cross-holes, to hold the diaphragm up and to keep the valve plunger from rotating. The proper size tool is included in the Wanner Tool Kit. (Don't remove the tool until the new diaphragm is installed in step “f” below.)
- c. Unscrew the diaphragm. Use a 5/16-in. (8-mm) open-end wrench, and turn counterclockwise.
- d. Inspect the diaphragm carefully. A damaged diaphragm generally indicates a pumping system problem and replacing only the diaphragm will not solve the larger problem. Inspect the diaphragm for the following:
  - **Small puncture.** Usually caused by a sharp foreign object in the fluid, or by an ice particle.
  - **Diaphragm pulled away** from the metal insert. Usually caused by excessive inlet vacuum, or by overpressurization of the pump inlet.
  - **Outer diaphragm bead extruded.** Usually caused by overpressurization of the pump or by extremely high temperatures.
  - **Diaphragm becoming stiff** and losing flexibility. Usually caused by pumping a fluid that is incompatible with the diaphragm material.
  - **Cut diaphragm convolute.** Usually caused by excessive inlet vacuum.

**CAUTION: If a diaphragm has ruptured and foreign material or water has entered the oil reservoir, do not operate the pump. Check all diaphragms, then flush the reservoir completely (as outlined below) and refill it with fresh oil. Never let the pump stand with foreign material or water in the reservoir, or with the reservoir empty.**

- e. Clean away any spilled oil.
- f. Install a good or new diaphragm and tighten to 10 in.-lbs (110 N-cm).
- g. Repeat the above inspection procedure (and replacement, if necessary) with the other four diaphragms.

## 4. Flush Contaminant from Hydraulic End

**(only if a diaphragm has ruptured)**

- a. With the valve plate and manifold still removed (see above), remove the oil drain cap (26) allow all oil and contaminant to drain out.
- b. Fill the reservoir with kerosene or solvent, manually turn the pump shaft to circulate the kerosene, and drain. Dispose of this contaminated fluid properly.
- c. Repeat the flushing procedure (step “b” above).
- d. Fill the reservoir with fresh oil, manually turn the pump shaft to circulate the oil, and drain again.
- e. Refill the reservoir. If the oil appears milky, there is still contaminant in the reservoir. Repeat the flushing procedure until the oil appears clean.

## 5. Prime the Hydraulic Cells

- a. With the pump **horizontal and the fluid end head removed**, fill the reservoir with the appropriate Hydra oil for the application. Have a catch basin for oil that leaks from behind the diaphragms when priming. Catch the oil and dispose of it properly; **do not reuse it.**
- b. All air in the oil within the hydraulic cell (behind the diaphragm) must be forced out by turning the shaft (and thus pumping the piston). A Shaft Rotator is included in the Wanner D-15 Tool Kit. Rotate the shaft two revolutions and refill the reservoir. Rotate it two more revolutions and refill again. Continue to do this until the oil that is being pumped from the back of all five diaphragms is free of air.
- c. Wipe excess oil from the cylinder housing (23) and diaphragms (21).
- d. Ensure that the oil level is 1/4 in (6 mm) above the cast surface in the upper oil reservoir.
- e. Replace oil fill cap (28).

# D/G-15 Service (Fluid End)

---

## 6. Reinstall Valve Plate and Manifold (24, 4)

- a. Reinstall the valve plate (24), with the valve assemblies installed as outlined above, onto the cylinder housing center spud and alignment pin (8).
- b. Install capscrew (22) with flat washer (3) through center hole in valve plate and torque to 45 ft-lbs (60 N-m).
- c. Install new O-rings (5, 6, 7) into the grooves in the front side of the valve plate. Use grease or petroleum jelly to hold them in place.
- d. Reinstall the manifold (4) over alignment pin (8), engaging the center spud of the manifold into the center of the valve plate.
- e. Install capscrews (1) with flat washers (3) through the five center holes in the manifold. Thread each capscrew in several turns, but do not torque.
- f. Install capscrews (2) with flat washers (3) through the twelve outer holes at the perimeter of the manifold. Thread each capscrew in several turns, but do not torque.
- g. Return to the five capscrews at the center of the manifold and alternately tighten opposite bolts until all are secure. Torque to 45 ft-lbs (60 N-m).
- h. Return to the twelve capscrews at the perimeter of the manifold and alternately tighten opposite bolts until all are secure. Torque to 45 ft-lbs (60 N-m).
- i. Recheck all capscrews for tightness and proper torque, starting with the five at the center of the manifold, then the twelve at the perimeter.

# D/G-15 Service (Hydraulic End)

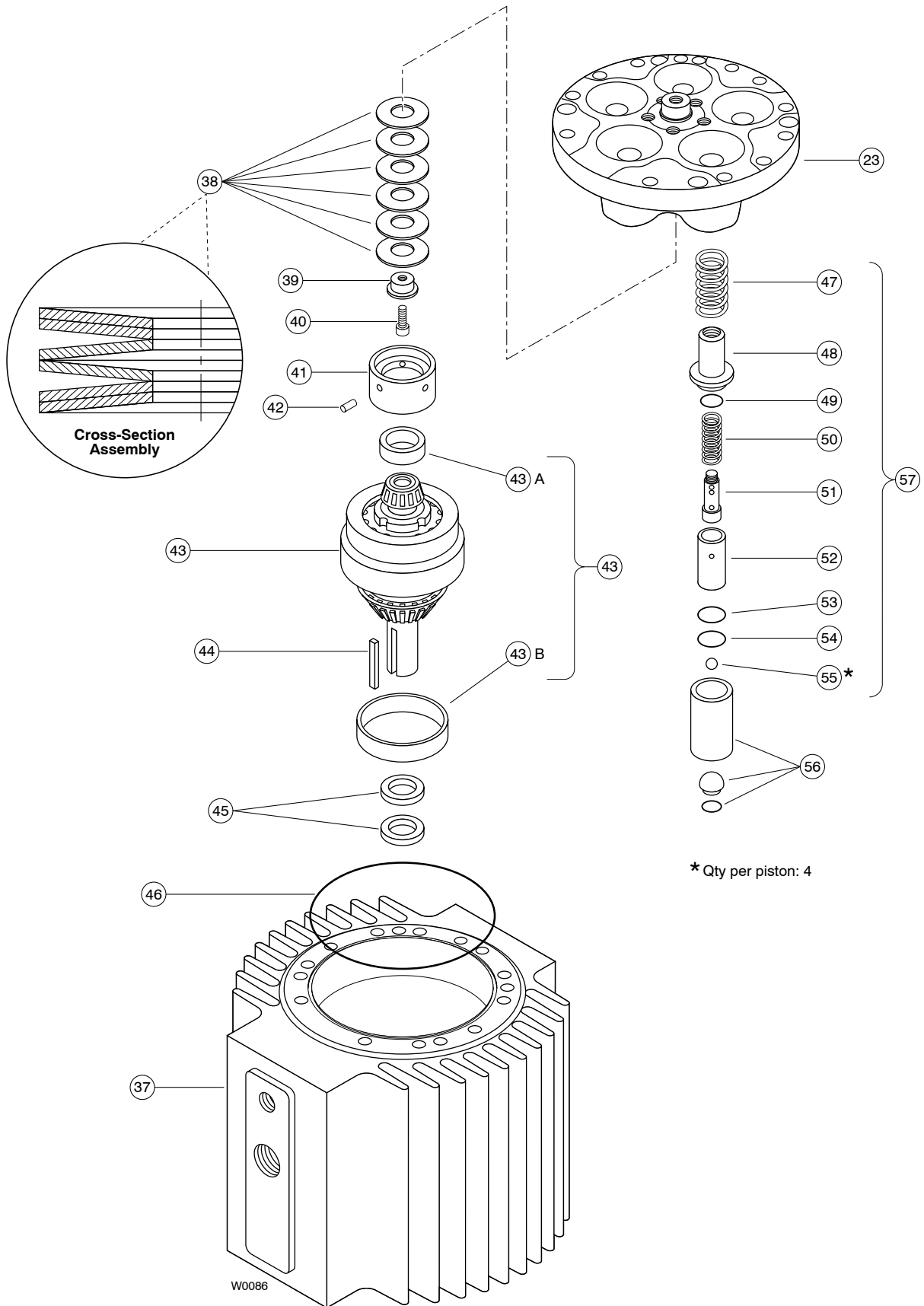

# D/G-15 Service (Hydraulic End)

**NOTE:** The numbers in parentheses are the Ref. Nos. on the illustrations in the Parts Manual.

This section explains how to disassemble and inspect the hydraulic end (oil reservoir) of the pump.

**CAUTION:** Do not disassemble the hydraulic end unless you are a skilled mechanic. For assistance, contact Wanner Engineering (612-332-5681) or the distributor in your area.

**CAUTION:** The four socket-head capscrews (29) that screw through the cylinder housing (23) into the pump housing hold these parts together. Do not remove these four screws except when repairing the hydraulic end.

**NOTE:** The following service procedures refer several times to the Wanner D-15 Tool Kit. We strongly urge you **not to repair** the hydraulic end of the pump without using the tools in this Kit (available from Wanner Engineering or your local distributor). Refer also to the list of tools and supplies in the Fluid-End Service Section.

## Service Procedure

**NOTE:** Before Step 1 Remove Pump Housing, scribe a line on the perimeter of the cylinder housing and onto the pump housing. This will simplify alignment during reassembly.

### 1. Remove Pump Housing

- Remove the manifold and valve plate, and the diaphragms, from the pump. Refer to the Fluid-End Service Section
- Drain the oil from the pump housing by removing the drain plug cap (26). Dispose of the oil properly.
- Check the shaft for sharp burrs. Smooth any burrs, to prevent scarring the seals (45) when removing the shaft.
- Reinsert two perimeter bolts (2) through the cylinder housing (23) into the pump housing (37), at the 10 and 2 o'clock positions, to support the parts as the pump is being disassembled.
- Remove the four socket-head capscrews (29) loosening alternately so the cylinder housing separates evenly from the pump housing. Slide the cylinder housing out on the two bolts (2) that were inserted for support in Step d above. The preload on the piston return springs will push the cylinder housing out of the pump housing. Remove the support bolts and cylinder housing assembly.

**NOTE:** the piston assemblies will be free to slide out of the cylinder housing, so keep the cylinder housing orientated with pistons up, for later disassembly.

- Remove the shaft assembly (43) sliding the shaft out of the seals (45). The parts are heavy.
- Remove the bearing adjustment plate (41) and inspect the bearing cup (43A). Inspect all parts for wear, and replace if necessary.
- Inspect the cam and bearings (43), and the bearing cup (43B) in the housing. If the bearings are pitted or binding, or if the bearing cup in the housing is worn, contact Wanner Engineering.

**CAUTION:** If a bearing cup or bearing cone is replaced, they must be replaced as a pair or premature failure will result.

### 2. Disassemble Pistons

Inspect and clean all parts of the hydraulic piston assemblies (57). Replace all O-rings and any other parts that are worn or damaged.

### 3. Reassemble Pistons

- Drop a ball (55) into each opening in the bottom of the piston assembly (56).  
**NOTE:** Using grease on the O-rings, and lubricating the parts, will aid in assembly.
- Insert a retaining washer (54) and O-ring (53) to hold the balls in place.
- Insert a valve plunger (51) into the valve cylinder (52). Slide a spring (50) over the valve plunger (51), inside the valve cylinder (52).
- Insert an O-ring (49) into the spring retainer (48).
- Slide the assembled valve cylinder (52), valve plunger (51), and spring (50) into the spring retainer (48).
- Slide the complete cylinder-and-retainer assembly into the piston assembly.
- Insert a piston return spring (47) into the piston assembly, with the larger end going into the piston first. This is a tight fit, and can best be done by "screwing" the spring in counterclockwise.
- Repeat the above procedure for the other four pistons.

### 4. Remove Shaft Seals (45)

Inspect the shaft seals (45) before continuing. If they look damaged in any way, replace them. Remove by pounding them out from inside the pump housing. Replace both shaft seals at the same time. Clean the bore in the housing using emery cloth or Scotch-Brite™.

### 5. Reassemble Pump Housing (37), Cam Assembly (43), and Cylinder Housing (23)

- With the pump housing vertical and the baseplate removed, set it with the open end up on a workbench. Grease the groove at the face of the housing and install O-ring (46). Set aside.
- Set the cylinder housing, with the diaphragm pockets facing down, onto smooth, clean, 4" high blocks. Insert the bearing adjustment plate (41), with the bearing cup (43A) and dowel pin (42) into the cylinder housing. The dowel pin engages into the largest of the five slots in the cylinder housing.



# D/G-15 Service (Hydraulic End)

---

- c. Insert the five piston assemblies into the cylinder housing.
- d. Set the cam assembly onto the cylinder housing sub-assembly such that the piston feet support the cam assembly and the nose bearing is centered over bearing cup (43A). Note: the cam assembly will be able to move from side to side slightly, as the nose bearing is not fully engaged into the bearing cup.
- e. If the shaft seals (45) are still in the pump housing, slide the seal protector (from the D-15 Tool Kit) over the shaft. Pick up the pump housing, lining up the marks made earlier on it and the cylinder housing. Slowly lower the pump housing over the shaft until the bearing cup (43B) rests on the upper bearing of the cam assembly.
- f. Start the four capscrews (29) by hand, using the 6 mm hex Allen wrench from the Wanner D-15 Tool Kit. Thread them through the counter bored holes in the cylinder housing, engaging the threads into the pump housing. Two full turns of each screw should be able to be achieved before noticeable resistance is met from the piston return springs. If this cannot be done remove the pump housing and check alignment of the cam assembly to the cylinder housing subassembly.
- g. Install baseplate (30) onto pump housing using capscrews (32) and lockwashers (31). The longer end (stamped FRONT) of the baseplate goes down, toward the cylinder housing. Apply thread locker (e.g. Loctite 242) to the threads of the capscrews and torque to 45 ft-lbs (60 N-m).
- h. Lift the pump assembly off of the 4" blocks and set it onto the workbench. Tip the pump assembly so it sits upright on the baseplate.

**Return to the four cylinder housing capscrews (29) and tighten them to establish and maintain an even gap between the cylinder housing and pump housing. This will draw the cylinder housing into the pump housing, compressing the five piston return springs and the six disk springs that pre-load the cam assembly. Note: there is very minimal clearance between the cylinder housing pilot diameter and the main pump housing bore, so it is very important to alternately tighten the four capscrews, until the housings are flush together. The last 1/8" (3mm) requires more force to bring the housings together as all of the springs are nearing their maximum compression. Torque all four capscrews to 15 ft-lbs (20 N-m). Remove the shaft seal protector.**

## 6. Install Shaft Seals (45)

- a. Apply a thin film of grease on the seal protector tool (included in the Wanner D-15 Tool Kit). Slide both seals onto the tool, with the spring side of the seals toward the open end of the tool. Apply a heavier coat of grease between the seals and press them together.
- b. Apply an anaerobic seal sealant or bearing retaining compound (e.g. Loctite 601 or 609) to the outside diameter of the seals.
- c. Apply a light film of grease to the pump shaft and slide the seal protector (with seals) over the shaft.
- d. Slide the seal inserter tool (included in the Wanner D-15 Tool Kit) over the seal protector tool, and press the seals completely into place. Tap the tool with a soft mallet to firmly seat the seals flush to the pump housing.

## 7. Reinstall Diaphragms (21)

- a. Screw the plunger guide lifter (from the Wanner Tool Kit or Repair Kit) into the valve plunger (51). Pull out to expose the cross holes in the plunger. Rotate the shaft until the piston is at top dead center.
- b. Insert the 3/32-in. T-handle hex wrench (from the Wanner Tool Kit), through the plunger hole — to hold the plunger away from the cylinder housing (23), and to keep the plunger from turning when the diaphragm is being installed.
- c. Engage the diaphragm insert threads to the plunger threads, and turn the diaphragm by hand until the insert hits the shoulder of the valve plunger (51).
- d. Hold the T-handle hex wrench to secure the valve plunger, and torque the diaphragm insert to 10 in.-lbs (110 N-cm) using a 5/16-in. (8-mm) open-end wrench.
- e. Repeat the above procedure for the plungers and diaphragms of the other four cylinders.
- f. Fill the reservoir with fresh oil and prime the pump, as outlined in the Fluid-End Service Section.

## 8. Reassemble Pump

Reassemble the pump as outlined in the Fluid-End Service Section.

# D/G-15 Troubleshooting

---

## Cavitation

- Inadequate fluid supply because:
  - Inlet line collapsed or clogged
  - Clogged line strainer
  - Inlet line too small or too long
  - Air leak in inlet line
  - Worn or damaged inlet hose
  - Suction line too long
  - Too many valves and elbows in inlet line
- Fluid too hot for inlet suction piping system.
- Air entrained in fluid piping system.
- Aeration and turbulence in supply tank.
- Inlet vacuum too high (refer to “Inlet Calculations”, page 3).

## Symptoms of Cavitation

- Excessive pump valve noise
- Premature failure of spring or retainer
- Volume or pressure drop
- Rough-running pump
- Premature failure of diaphragms

## Drop in Volume or Pressure

A drop in volume or pressure can be caused by one or more of the following:

- Air leak in suction piping
- Clogged suction line or suction strainer
- Suction line inlet above fluid level in tank
- Inadequate fluid supply
- Pump not operating at proper RPM
- Relief valve bypassing fluid
- Worn pump valve parts
- Foreign material in inlet or outlet valves
- Loss of oil prime in cells because of low oil level
- Ruptured diaphragm
- Cavitation
- Warped manifold from overpressurized system
- O-rings forced out of their grooves from overpressurization
- Air leak in suction line strainer or gasket
- Cracked suction hose.
- Empty supply tank
- Excessive aeration and turbulence in supply tank
- Abrasives in the fluid
- Valve incompatible with corrosives in the fluid
- Pump running too fast
- Worn and slipping drive belt(s)
- Worn spray nozzle(s)

## Pump Runs Rough

- Worn pump valves
- Air lock in outlet system
- Oil level low
- Wrong weight of oil for cold operating temperatures (change to lighter weight)
- Cavitation
- Air in suction line
- Restriction in inlet/suction line
- Hydraulic cells not primed after changing diaphragm
- Foreign material in inlet or outlet valve
- Damaged diaphragm
- Fatigued or broken valve spring

## Premature Failure of Diaphragm

- Frozen pump
- Puncture by a foreign object
- Elastomer incompatible with fluid being pumped
- Pump running too fast
- Excess pressure
- Cavitation

## Water (or Process Fluid) in Oil Reservoir

- Condensation
- Ruptured diaphragm
- Hydraulic cell not properly primed after diaphragm replacement
- Frozen pump

## Water (or Process Fluid) Pulsations

**NOTE: Small pulsations are normal in single-acting pumps with multiple pumping chambers.**

- Foreign object lodged in pump valve
- Loss of prime in hydraulic cell because of low oil level
- Air in suction line
- Valve spring (12, 19) broken
- Cavitation
- Aeration or turbulence in supply tank

# D/G-15 Troubleshooting

---

## Valve Wear

- Normal wear from high-speed operation
- Cavitation
- Abrasives in the fluid
- Valve incompatible with corrosives in the fluid
- Pump running too fast

## Loss of Oil

- External seepage
- Rupture of diaphragm
- Frozen pump
- Worn shaft seal
- Oil drain piping or fill cap loose.
- Valve plate and manifold bolts loose
- Pump housing porosity

## Premature Failure of Valve Spring or Retainer

- Cavitation
- Foreign object in the pump
- Pump running too fast
- Spring/retainer material incompatible with fluid being pumped
- Excessive inlet pressure.

### **Limited Warranty**

Wanner Engineering, Inc. extends to the original purchaser of equipment manufactured by it and bearing its name, a limited one-year warranty from the date of purchase against defects in material or workmanship, provided that the equipment is installed and operated in accordance with the recommendations and instructions of Wanner Engineering, Inc. Wanner Engineering, Inc. will repair or replace, at its option, defective parts without charge if such parts are returned with transportation charges prepaid to Wanner Engineering, Inc., 1204 Chestnut Avenue, Minneapolis, Minnesota 55403.

This warranty does not cover:

1. The electric motors (if any), which are covered by the separate warranties of the manufacturers of these components.
2. Normal wear and/or damage caused by or related to abrasion, corrosion, abuse, negligence, accident, faulty installation or tampering in a manner which impairs normal operation.
3. Transportation costs.

This limited warranty is exclusive, and is in lieu of any other warranties (express or implied) including warranty of merchantability or warranty of fitness for a particular purpose and of any noncontractual liabilities including product liabilities based on negligence or strict liability. Every form of liability for direct, special, incidental or consequential damages or loss is expressly excluded and denied.



## **WANNER ENGINEERING, INC.**

1204 Chestnut Avenue, Minneapolis, MN 55403  
TEL: (612) 332-5681 FAX: (612) 332-6937  
TOLL-FREE FAX [US only]: (800) 332-6812

[www.hydra-cell.com](http://www.hydra-cell.com)  
email: [sales@wannereng.com](mailto:sales@wannereng.com)

© 2004 Wanner Engineering, Inc. Printed in USA  
D15-991-2400A 5/2004, Revised 2/2007