



Self-Priming Engine Driven Utility Pumps

- **Aluminum Construction**
- **Buna-N Mechanical Seal and O-Ring**
- **2" to 3" NPT Port Sizes**
- **Portable, Lightweight**
- **Solids Handling and Dirty Water Design**
- **Semi-Open, Clog Resistant Impeller**
- **Engine 4-Cycle Options:**
 - ◆ **Model GCW2L/GCW3L: LCT Engine**



Model GCW2L

The AMT/IPT line of Engine Driven Utility pumps offers economy, durability, portability and performance all in one neat package. Ideal for general purpose dirty water dewatering, irrigation, spraying, washdown and agricultural applications. Pumps are designed to handle liquids with solids content or dissolved solids and debris.

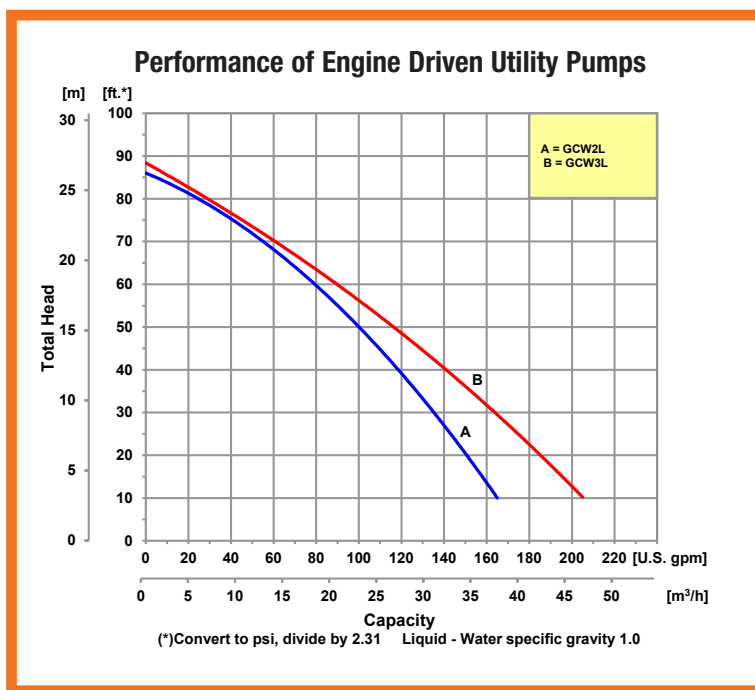



Engine Driven Utility Pumps

2"-3" General Purpose Pumps

Model	Curve	Driver	Run Time (Hours)	Tank Size (Gal/Ltr.)	Ship Wt. (Lbs.)
GCW2L	A	LCT 208CC	2.2	0.71/2.7	55
GCW3L	B	LCT 208CC	2.2	0.71/2.7	60

Construction: Cast Aluminum

Maximum Solids Handling Capacity: 1/4" Diameter

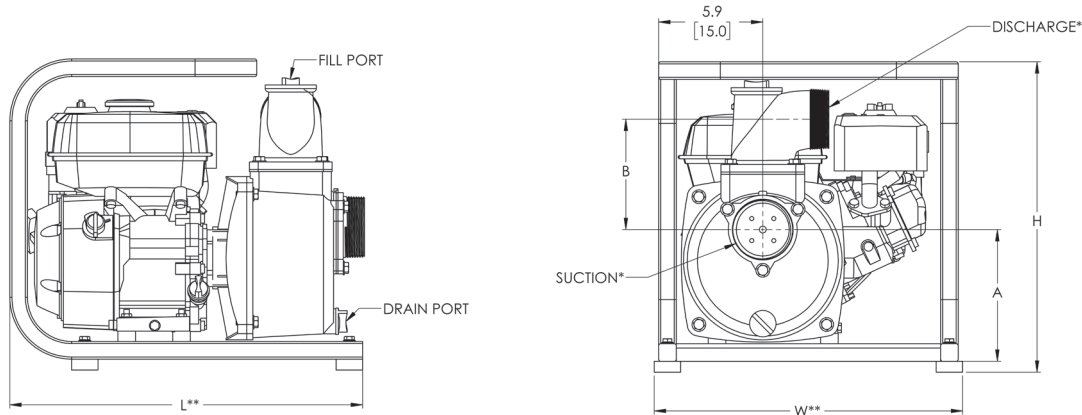

Standard Features

- Buna-N Mechanical Seal and O-ring
- O-ring Casing Seal
- Semi-open, Clog Resistant Impeller
- Self-primers to 20 Ft.
- Maximum Temperature 180° F
- Maximum Working Pressure 75 PSI
- Delivers up to 38 PSI
- Maximum of 205 GPM
- Includes Heavy Duty Steel Roll Frame, Hose Clamps, Strainer, and Hose Fittings
- QSP - Quick Ship Pump

Model	HP Class ♦	Curve	SUC*	DIS*	A	B	L**	W**	H
GCW2L	5HP	A	2"	2"	6.6 [16.8]	5.3 [13.3]	20.0 [50.8]	17.5 [44.4]	17.6 [44.7]
GCW3L	5HP	B	3"	3"	7.5 [19.0]	6.3 [15.9]	20.0 [50.8]	17.5 [44.4]	17.6 [44.7]

♦ HP Class represents market category and is not intended to define actual horsepower.
 (*) Standard NPT (Female) pipe thread.
 (**) This dimension may vary due to engine manufacturer's specifications.
 NOTE: Dimensions are in inches (centimeters) and have a tolerance of ± 1/8".



Illinois Location:
 (847) 841-7867
 860 Church Rd Elgin, IL 60120

Minnesota Location:
 (651) 758-7867
 330 Mill Bay South Suite
 Afton, MN 55001

PumpSupplyInc.com

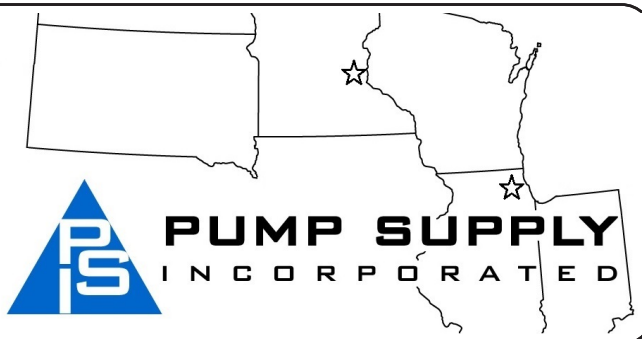

1222