

VERTIFLO

SERIES 1600 Vortex End Suction

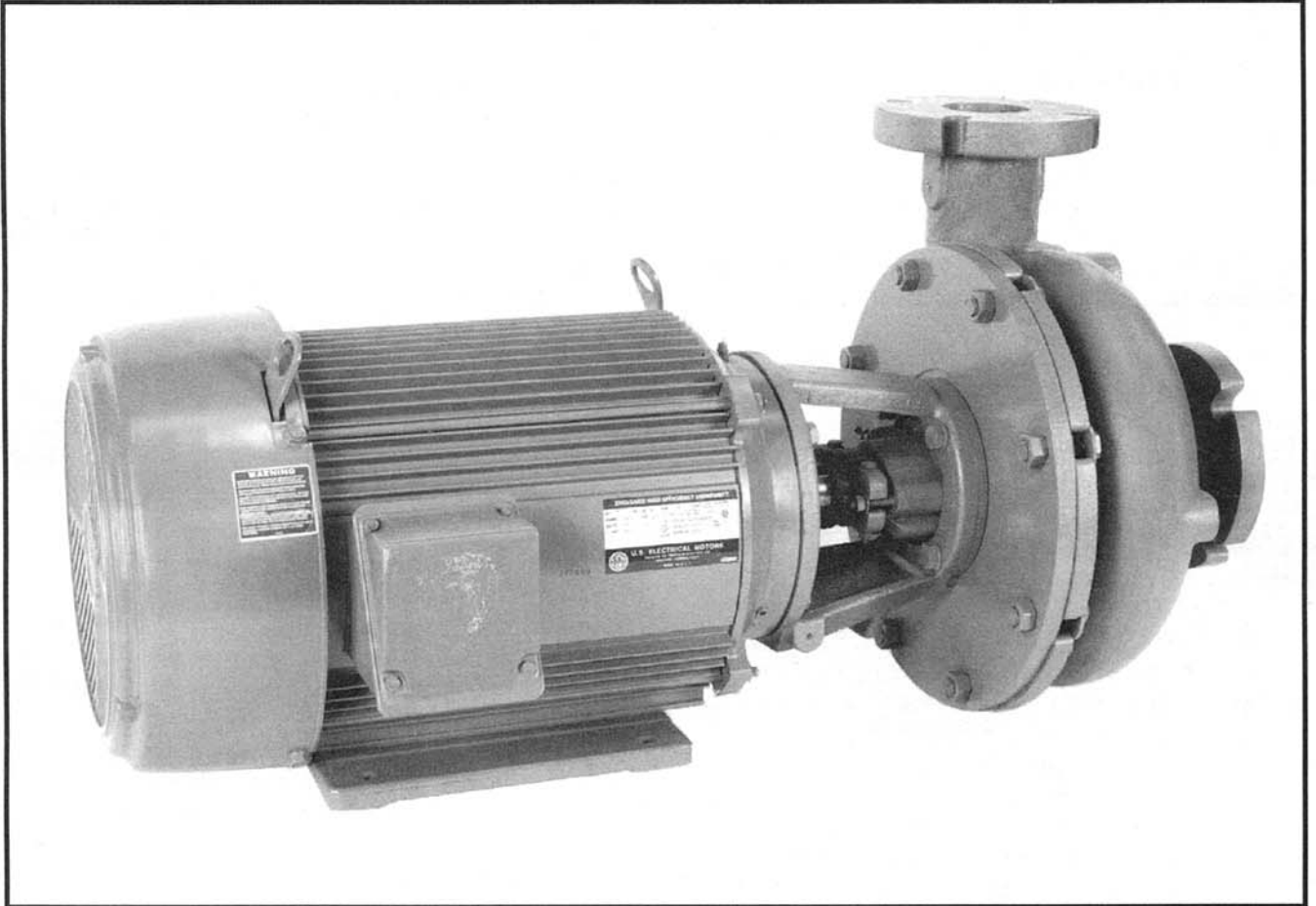

**Installation, Operation
& Service Instructions**

I. INSTALLATION INSTRUCTIONS

VERTIFLO horizontal close-coupled pumps are completely assembled., carefully adjusted and prelubricated at the factory before shipment.

- A. Carefully set pump at the required location. Check for full contact of the motor base to the foundation.
- B. Secure pump to foundation by bolting, etc.; whatever is convenient or required for the installer.
- C. Connect the system piping to the pump; suction piping to the flange at the end of the pump and discharge piping to the flange which is part of the casing (51). A check valve and gate valve should be installed in the discharge piping and a gate valve in the suction piping. An elbow in the suction piping should not be closer to the pump than the equivalent of 5 times the suction pipe diameter.

Note: All piping is to be supported independent of the pump. No piping strain is to be imposed on the pump.

- D. Connect power lines to motor leads as shown on the wiring diagram of the motor for specific line voltage used.

Follow all state and local wiring codes.

- E. Check and be sure starter and overload protection is proper for specific voltage and for the amperage rating.
- F. Check for free rotation by turning the shaft. Binding in the pump is caused by (1) PIPING STRAIN (2) IMPELLER OUT OF ADJUSTMENT — (See IMPELLER ADJUSTMENT, Section III).
- G. Jog motor quickly to check for proper rotation. Shaft rotation should be clockwise when looking from the motor end. If pump rotation is incorrect, contact a qualified electrician to make necessary corrections.
- H. Open suction line gate valve. Close discharge line gate valve and start pump. Open discharge line gate valve SLOWLY until desired capacity is obtained. Pump should now operate smoothly. If vibration occurs, check for pipe stress.

- I. Packed pumps are shipped with loosely adjusted glands (25). If excessive leakage occurs, evenly tighten the two packing nuts until leakage is a drip.

NOTE: DO NOT TIGHTEN PACKING GLAND UNTIL ALL LEAKAGE STOPS. PACKING MUST HAVE SOME LEAKAGE FOR LUBRICATION. OVERTIGHTENING WILL BURN PACKING AND SCORE THE SHAFT. SLEEVE.

II. LUBRICATION

Series 1600 pumps are properly lubricated at the factory. Further on-site lubrication schedules depend upon local conditions. It is recommended that packing be periodically inspected and greased.

- A. Packing (22) should be greased every two or three months
- B. Motor should be lubricated in accordance with manufacturer's recommendation.

III. IMPELLER ADJUSTMENT

Impeller adjustment is accomplished by shimming behind the impeller until clearance of approximately .030" to .045" is obtained between the case adaptor and the impeller.

IV. LIQUID END INSPECTION

NOTE: Before disassembly, match mark parts for ease in reassembly.

- A. Turn off electrical supply to the motor and all controls. Close suction line and discharge line gate valves. Remove drain plug from casing and drain pump.
- B. Remove the four cap screws in the motor feet.
- C. Remove cap screws (55) holding case adaptor to casing.
- D. Pull motor and rotating assembly straight out, leaving the casing (51) connected to the piping.
- E. To remove impeller (50), remove impeller screw (5) by holding the impeller and turning the impeller screw counterclockwise. Remove impeller washer (4), and impeller washer gasket (6).
- F. Remove impeller key.

V. PUMP ASSEMBLY

- A. Remove shims (8).
- B. Remove the four cap screws holding the packing box or seal head (21), and case adaptor (53) to the motor adaptor (1).
- C. Remove case adaptor (53).
- D. Remove packing box or seal head (21), and sleeve (2) as an assembly.
- E. Remove slinger (9).

VI. REASSEMBLY OF PUMP UNIT

- A. Install slinger (9) by sliding over shaft.
- B. If packed pump, slide gland (25) over the shaft to the slinger.
- C. Slide packing box over the end of shaft until seated against motor adaptor (1). If mechanically sealed pump, press stationary face into seal head before installing seal head.
- D. Place gasket (56) over packing box and insert four cap screws (10, 11) into motor adaptor through packing box.
- E. Seat case adaptor (53) into packing box using cap screws to align holes and gasket. Tighten cap screws.
- F. Install sleeve (2) aligning key in sleeve with keyway in the shaft. Install shims (8). If parts have been replaced which might affect the face clearance, install 2 shims as a starting point. Align keyway groove in shims with keyway in sleeve and insert impeller key (3).
- G. Install packing or mechanical seal. If packed pump, install three rings of packing (22); next the lantern ring (23), then fill packing box with additional rings without overfilling. The cut edges of each packing ring should be placed 180 degrees from the previously installed piece. Slide the gland until it contacts the packing and install gland washer and nuts. Tighten fingertight. If sealed pump, install seal (24) per manufacturer's recommendation.

VII. ASSEMBLY OF LIQUID END

- A. Slide impeller (50) over shaft, aligning keyway to key.
 - B. Install "O" ring on impeller screw (5).
 - C. Install impeller gasket (6), impeller washer (4) with ID chamfer away from the impeller screw (5), and tighten.
 - D. Set impeller as described in IMPELLER ADJUSTMENT (Section III).
 - E. Slide motor assembly into casing (51).
- NOTE: BE CAREFUL NOT TO FORCE MOTOR ASSEMBLY INTO CASING. CASING MAY HAVE SHIFTED DUE TO PIPE STRAIN. IF THIS IS THE CASE, REALIGN CASING WITH MOTOR ASSEMBLY.
- F. Loosely install four cap screws in feet of motor. Install cap screws in case adaptor (53) and tighten. Tighten cap screws in feet.
 - G. Replace drain plug in casing.
 - H. Check for free rotation.
 - I. Turn on electrical supply to motor.
 - J. Open suction line and discharge line gate valves.

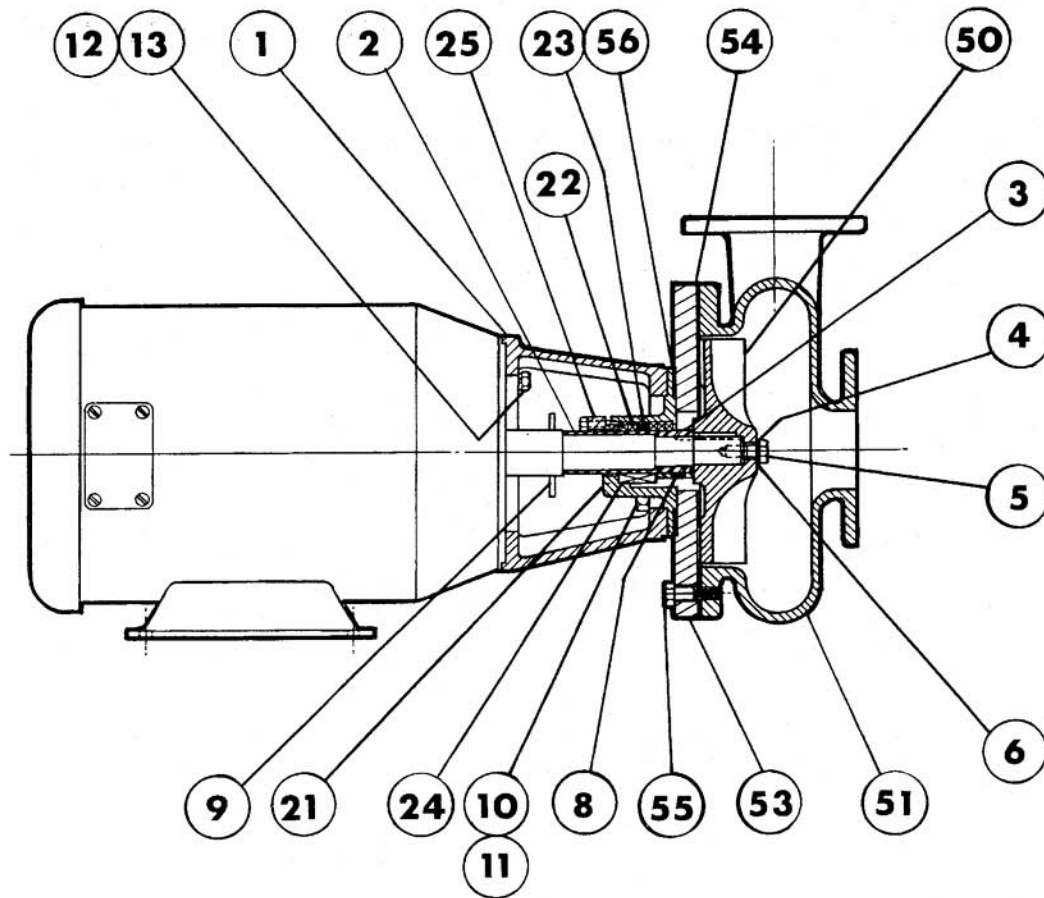

ITEM	DESCRIPTION	ITEM	DESCRIPTION
1	MOTOR ADAPTER	21	PACKING BOX/SEAL HEAD
*2	SHAFT SLEEVE	*22	PACKING
3	IMPELLER KEY	23	LANTERN RING
4	IMPELLER WASHER	*24	MECHANICAL SEAL
5	IMPELLER SCREW	25	PACKING GLAND
6	IMPELLER WASHER GASKET	50	IMPELLER
8	SHIMS	51	CASING
*9	SLINGER	53	CASE ADAPTOR
10	CAP SCREW	*54	CASE GASKET
11	CAP SCREW	55	CAP SCREW
12	CAP SCREW	*56	GASKET
13	CAP SCREW		

*Recommended Spare Parts
Refer to Pump Serial Number and Part Item Number
when ordering parts.

VERTIFLO PUMP CO., INC.
7807 Redsky Drive
Cincinnati, Ohio 45249

VERTIFLO

e-mail sales@vertiflo.com
world wide web: <http://www.vertiflo.com>